

# ENERGY DISTRIBUTION SYSTEMS WITH MULTIPLE ENERGY CARRIERS

Bjørn H. Bakken\*

Michael M. Belsnes  
SINTEF Energy Research

Jarand Røystrand

(Norway)

## SUMMARY

*A flexible and robust methodology for analysis of complex energy distribution systems with multiple energy carriers is currently under development. The methodology includes technological, economic and environmental aspects, and will enable energy companies to carry out comprehensive analyses of their investments as well as overall optimisation of their energy supply systems. Governmental bodies will be able to do comprehensive scenario studies of local energy systems with respect to environmental impacts and consequences of different regulating regimes. The methodology is based on two main levels of modelling: First, components with standard interface are combined to generate an energy network. Internally, these components are represented with the necessary mathematical details, but seen from a system perspective they are all represented by a few standard variables. The overall system analysis and optimisation is then carried out on a generalized nodal model without knowledge of the specific types of components involved. The optimisation is based on multi-criteria techniques to include factors like investments, energy efficiency and environmental aspects.*

**KEYWORDS:** Energy distribution systems - Multi-objective optimisation - Waste fuel plant

## 1. INTRODUCTION

Generally, energy systems consist of three types of processes: Energy *transport* over a geographical distance (AC or DC lines, gas pipelines, LNG transport, district heating etc), *conversion* between different energy carriers (gas power plant, CHP, heat pumps etc) and *storage* of energy (batteries, LNG/gas tanks, heat storage etc). The general approach in planning an optimal energy system will be a multi-criteria decision problem where the objective is to find

an optimal network of processes, based on the properties of the different processes.

New technologies like small-scale co-generation, gas engines and fuel cells enable an increasing flexibility in energy distribution systems. This will result in more complex problems, but will also create new alternatives and possibilities to design an optimal distribution system under consideration of economy, energy efficiency and environmental aspects. Examples of situations with complex problems related to optimal co-ordination between different alternative energy carriers are: Development of a new suburb (including school, kindergarten, shopping center, medical center etc), design of new energy-efficient office buildings, or development of modern industry areas. The ability to combine different components and energy carriers in an overall analysis of such complex energy systems will enable greater flexibility of solutions and more alternatives than classic technical-economic analyses.

## 2. ANALYSING COMPLEX ENERGY SYSTEMS

The main idea of the methodology is based on the knowledge and experience among electro-technical specialists on complex network structures, load flow models and linear programming. In this project, however, the concept is further developed from flow of electric current to generic *flow of energy*. Specialists from other fields are involved to model the different processes and components (Thermal energy, Refrigeration/Air Conditioning etc.). A major objective is to handle different components at different geographical locations, connected by an energy distribution system.

As an example of the methodology a study case with a municipal small-scale waste plant project is shown in Fig. 1. The figure is an illustration of which processes might be used in a county/region that uses combined heat and power supply based on biomass and waste

\* SINTEF Energy Research, N-7465 Trondheim, Norway; Email: bjorn.bakken@energy.sintef.no

fuel, and is more comprehensive than the actual case, which is described in Section 4. The main electricity and district heating networks are omitted from the figure for simplicity. Note that the current project consists only of the waste fuel processes drawn above the dashed line.

Available energy resources are shown on the left in the figure: Waste from municipal and business offices, institutions and companies, gas from old land fills and biomass and waste from forestry and farming. These energy resources have to be transported, processed and stored in different locations and forms before converted to end user energy like electricity and heat. Often a choice has to be made between large centralized CHP units feeding local electricity and district heating networks, or remote mini-CHP installations in single buildings like offices, schools, health care centers etc.).

The model will treat energy transport by pipeline and power line, as well as by road.

The following methodology is to be used:

- Based on a library of available components, the user builds a model of the distributed energy system with the alternative solutions to be optimised as shown in Fig. 1.
- Each component is internally modelled with the necessary mathematical details.
- The connection to the linear network is made by a simple and unambiguous set of variables like cost, energy efficiency and energy quality/environmental aspects.
- The network analysis is made on a generic nodal model as in Fig. 2 without specific knowledge of which components are involved.

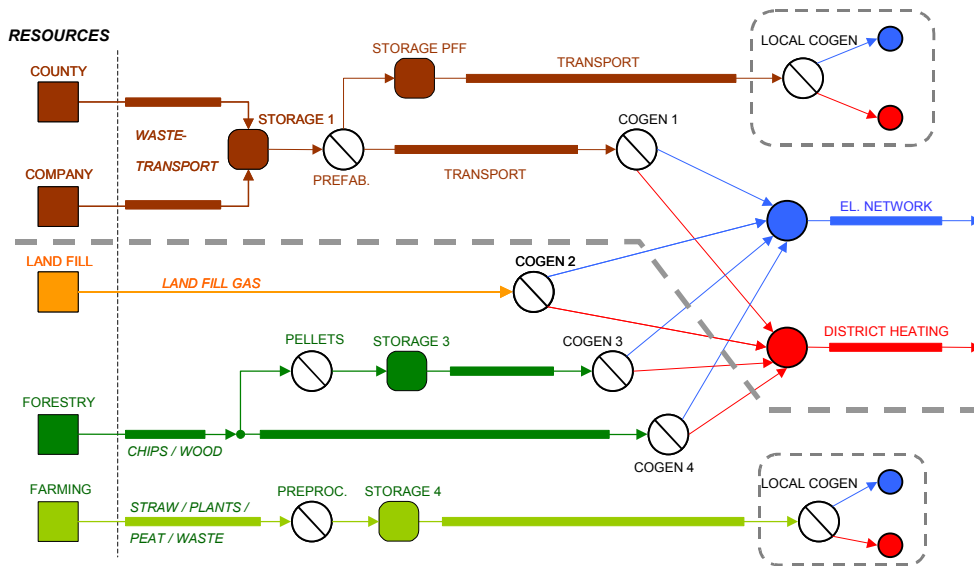

**Fig. 1 Simplified municipal energy system model**

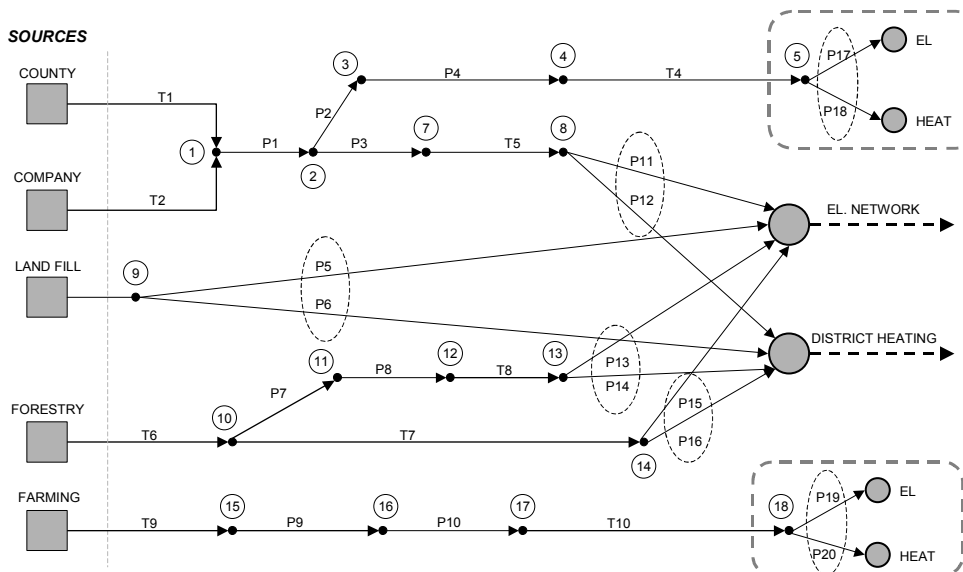

**Fig. 2 Generic energy network model**

### 3. HYBRID OPTIMIZATION TECHNIQUES

A major challenge in analyses of such complex systems is to combine a multi-criteria objective with the modeling demands of a variety of different energy processes. Adding the complexity and time span of the investment analysis creates an optimization problem not easily solved using conventional methods.

In this approach an important goal is to reduce the number of manual assumptions by separate modeling of each energy technology with sufficient detail. It is easy to argue against such an approach because some simplifying assumptions have to be made in any case. It is impossible to account for all physical aspects in one model due to the different properties of the processes involved. The reason why this approach is able to obtain these goals without compromising the main physical characteristics of the processes involved, is the option of combining different optimization methods.

Combination of different optimization methods adds new possibilities to the modeling of the energy related problems. It is not necessary to account for everything in one large model, as input from other models can be used in the areas where the “all-in-one models” meet limitations. An example of such a successful hybrid approach, is a model that combines the long-term hydropower operation strategy calculated with stochastic dynamic programming with a detailed deterministic sub-problem within one week [1]. It is not possible to account for every aspect of the hydropower system when calculating the long-term strategy. This makes the results less reliable if the modeled system does not meet certain assumptions. By using a deterministic equivalent to calculate the impact of this strategy it is possible to account for properties that cannot be included in stochastic optimization.

A similar approach will be used in the case of energy distribution systems with multiple energy carriers. Detailed process models are created to account for properties that are difficult to combine without simplifying assumptions. The basic principles are shown in Fig. 3. Results from the component models are used in the linear system model to calculate the optimal operation plan over the selected time period (day/week) for a given topology alternative.

The optimal operation planning kernel as shown in Fig. 3 must be integrated with an investment analysis scheme to choose the best possible expansion plan over the planning horizon. The overall concept can then be outlined as in Fig. 4. To be able to handle a hybrid model like this, it is important that the operation planning algorithm is fast. Also, the number of alternative topologies of the local energy system (new or expanded components, processes, transport channels etc.) as specified by the user is limited.

The design of the Graphical User Interface (GUI) is not yet specified. Integration with existing Geographic Information Systems (GIS) is a possible alternative.

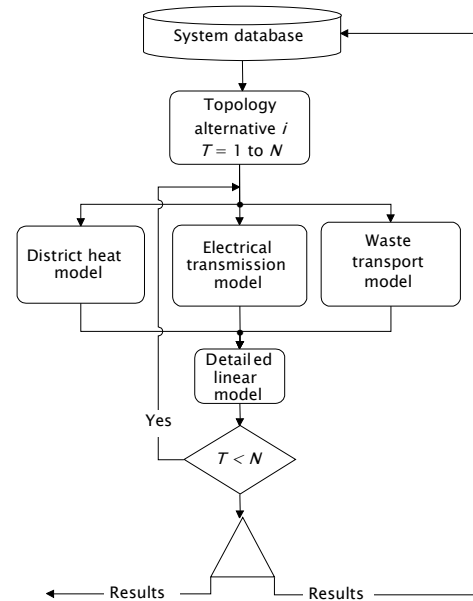

Fig. 3 Operation planning kernel with linear modeling

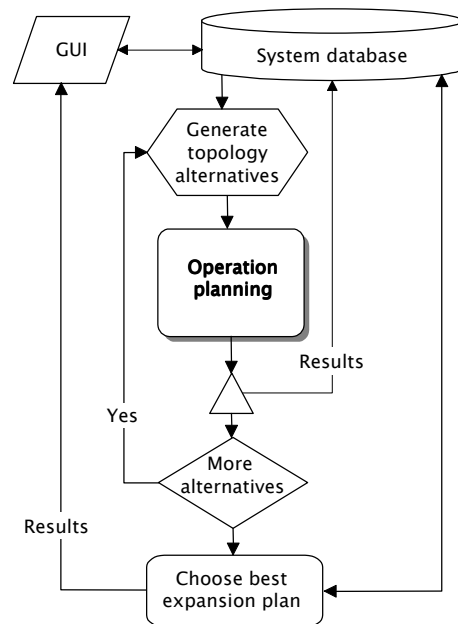

Fig. 4 Investment analysis integrated with operation planning kernel

### 4. STUDY CASE: MUNICIPAL SMALL-SCALE WASTE PLANT PROJECT

Regular testing and evaluation of methodology and models with realistic data during the development phases is important. One of the selected cases to be used is a small-scale waste cogeneration plant in a municipality south of the city of Trondheim. The waste cogeneration plant will supply a local district heating network with 17.1 GWh heat and 6.1 GWh electricity. The district heating network will have a total length of approximately 2 km, with the major customers of municipal administration and office buildings, local

industry, schools and health care institutions within a radius of 500 m from the waste plant. Installing mini-CHP units in more remote locations is also possible.

The waste plant is based on the PYROARC process for gasification and pyrolysis treatment of municipal, industrial and hazardous waste. In the development of the PYROARC concept utilisation of by-products and energy efficiency have been regarded as important as complete decomposition of harmful and toxic compounds. The waste has thus been considered more as a raw material for energy and material production rather than something troublesome that has to be destroyed. The PYROARC process is designed as a two-stage process: Solid waste material is charged to a shaft furnace to gasify the organic part to a partly oxidised pyrolysis gas and to smelt the inorganic part to a slag and metal melt. The pyrolysis gas is then completely decomposed together with liquid and gaseous waste material in a plasma augmented decomposition reactor. In this way the conditions for each reaction (gasification, decomposition and smelting) can be optimised and no material will escape the process without being exposed to sufficiently high temperature. The products leaving the process are: fuel gas, leach resistant slag, molten metal and small amounts of secondary dust which normally can be used for zinc and lead recovery.

The produced fuel gas is a lean gas with a heat value of about 4 MJ/m<sup>3</sup> and a carbon monoxide plus hydrogen content of 35-40%. This gas will be used in a gas engine for heat and power generation. Since the gas is low in NO<sub>x</sub> and lean it generates only small amounts of NO<sub>x</sub> during combustion. NO<sub>x</sub> removal will not be necessary.

## RÉSUMÉ

*Les nouvelles technologies telles les microcentrales, les turbines à gaz et les piles à combustible augmentent la souplesse des systèmes de distribution de l'énergie. Ce développement engendre des problèmes plus complexes mais ouvre aussi la voie à de nouvelles alternatives permettant de concevoir un système de distribution optimal qui tienne compte à la fois de la rentabilité, des économies d'énergie et de l'environnement. Une méthodologie solide qui reste cependant flexible est actuellement à l'étude. Elle permet l'analyse de systèmes de distribution de l'énergie complexes impliquant de nombreux distributeurs. Cette méthodologie traite à la fois des aspects techniques, économiques et environnementaux et permettra aux entreprises fournissant l'énergie de mener à bien des analyses détaillées sur leurs investissements et également d'optimiser leur système de distribution. Les agences gouvernementales pourront établir des scénarios complets afin de réguler les systèmes de production d'énergie en réduisant leurs impacts sur l'environnement et les conséquences des différents régimes de régulation du niveau des eaux. Cette méthodologie s'appuie sur deux principaux niveaux de simulation: Tout d'abord, les paramètres avec une interface standard sont associés par l'utilisateur pour produire un réseau d'énergie. Ces paramètres internes sont constitués par des modèles mathématiques détaillés mais dans une perspective de système, ils sont tous représentés par quelques variables standard. L'analyse globale du système et son optimisation sont réalisées sur la base d'un modèle de réseau type qui ignore les paramètres spécifiques en jeu. L'optimisation est fondée sur des techniques aux critères multiples qui incluent les investissements, les économies d'énergie et les aspects environnementaux. Cette méthodologie a pour objectif principal d'être applicable à l'ensemble des technologies de production d'énergie. Cette approche peut facilement faire l'objet de critiques puisqu'elle utilise nécessairement des hypothèses simplifiées. Il est, en effet, impossible de tenir compte de toutes les composantes physiques dans un modèle unique vu la complexité des processus en jeu. Nous pensons, néanmoins, que cette approche atteint tous ces objectifs sans pour autant compromettre les principales caractéristiques physiques des processus. Le choix délibéré de combiner plusieurs méthodes d'optimisation permet d'éviter cet écueil. Des modèles détaillés sur les processus sont élaborés pour prendre en compte les propriétés spécifiques qui sont difficiles à associer sans trop les simplifier. Les résultats de ces modèles sont ensuite utilisés dans un second modèle linéaire afin d'obtenir les résultats recherchés.*

## 5. CONCLUSIONS

This paper outlines the development of a new methodology for analysis of complex energy distribution systems with multiple energy carriers. The methodology is based on two main levels of modelling where specific component modules with a standard interface are combined in an energy system, which is then generalized to a nodal network with generic energy flow. To enable a multi-criteria optimisation with a minimum of simplifying assumptions which might limit the validity of the results, hybrid optimisation techniques will be implemented, e.g. combinations of stochastic dynamic programming and deterministic short-term optimisation. Each energy technology is modelled separately with sufficient detail, supplying the superior linear system model with a simple and unambiguous set of variables like cost, energy efficiency and environmental impact. The methodology will enable energy companies to carry out comprehensive analyses of their energy supply systems, and governmental bodies will be able to do comprehensive scenario studies of energy systems with respect to environmental impacts and consequences of different regulating regimes.

## 6. REFERENCES

- [1] A. Haugstad, B. Mo, M.M. Belsnes: Evaluating expansion or refurbishment in a deregulated electricity market (Proc. of Hydropower '97, Trondheim, Norway)