

Lean - et overblikk

Daryl Powell
ダイルパウエル
NTNU/SINTEF
"LEAN i LAG" Seminaret
23. september 2010



Hva er Lean?

...Lean betyr eliminering av sløsing (Liker, 2006)

"den eneste vi gjør er å se på tidslinjen fra det øyeblikket kunden gir oss en ordre til det punktet vi får pengene. Og vi reduserer den tidslinjen ved å eliminere sløsing"

"All we are doing is looking at the timeline from the moment the customer gives us an order til the point we collect the cash. And we are reducing that time line by removing the waste"

Taiichi Ohno, 1988

Lean- Vs. Masseproduksjon...

OK, vi har svelget "grisen", hva nå?!

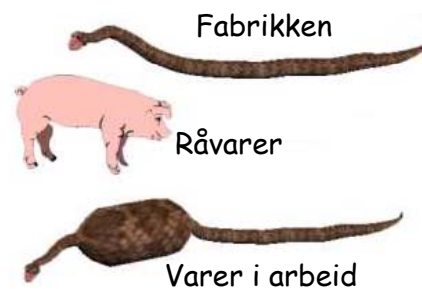

Lean Production: The Toyota Production System (TPS)

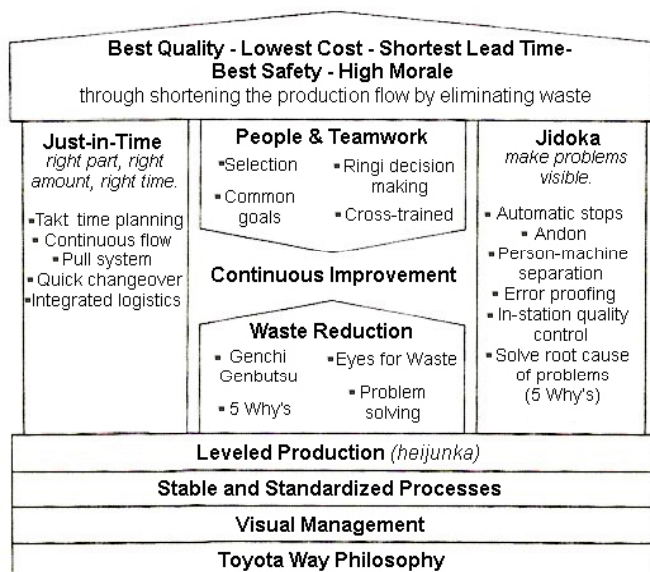

Basert på prinsippene og arbeidsprosessene hos Toyota...

Liker (2004)

Fem Lean Prinsipper:

1. Verdi (*Value*)
2. Verdistrøm (*Value stream*)
3. Flyt (*Flow*)
4. Sug (*Pull*)
5. Fullkommenhet (*Perfection*)

Womack og Jones (1996)

Verdistrømskartlegging:

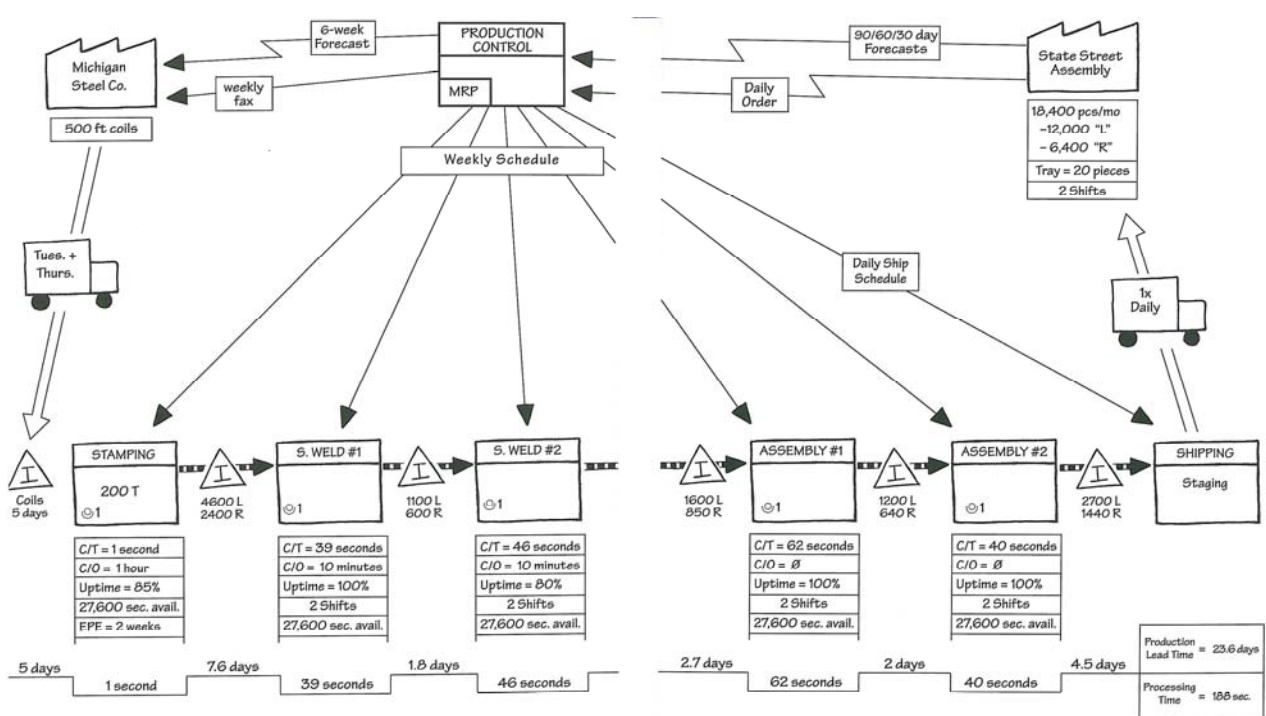

Verdistrømskartlegging i praksis:

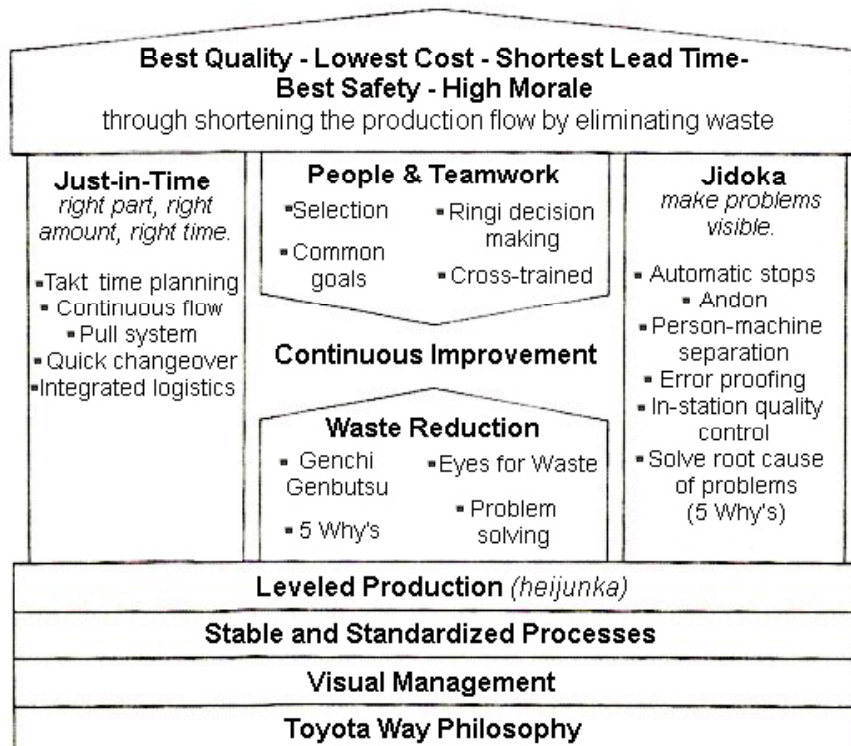

Liker (2004)

Visual Management - 5S

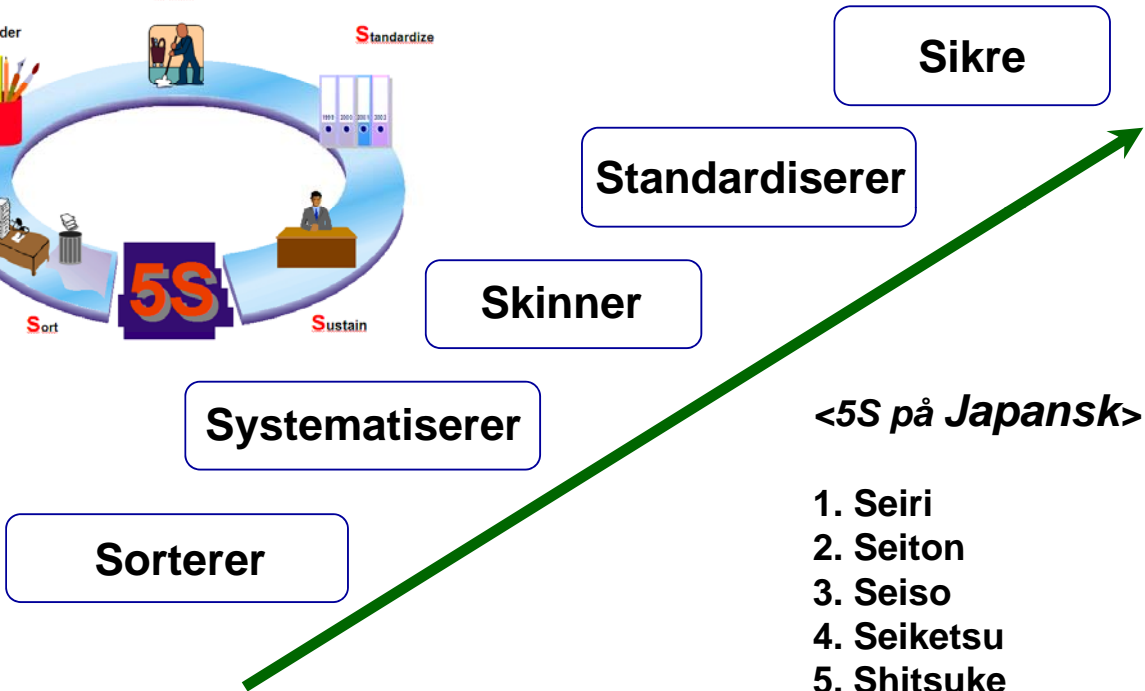
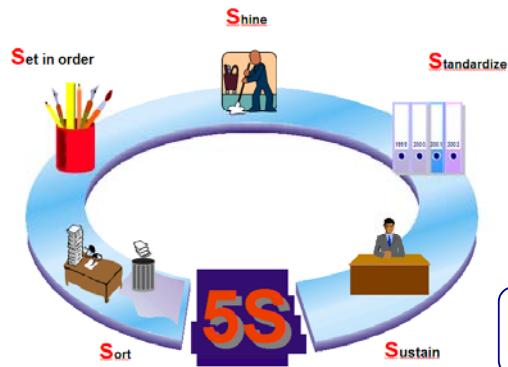

<5S på Japansk>

1. Seiri
2. Seiton
3. Seiso
4. Seiketsu
5. Shitsuke

Livet uten 5S:



Livet med 5S:

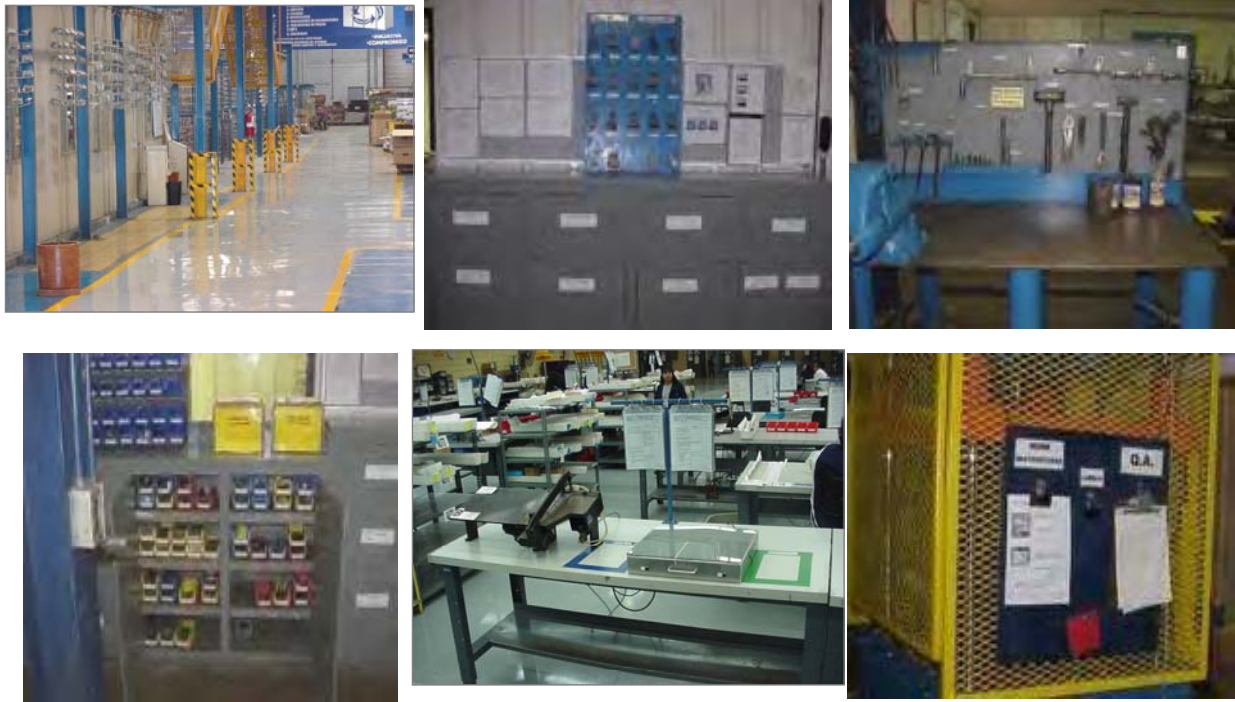

Standardisering av prosesser:

"De første at jeg gjorde var å standardisere jobbene. Og så instruerte jeg arbeiderne på produksjonsgulvet om å revidere metodene kontinuerlig, ved å forklare at "du stjele penger fra selskapet om du ikke forbedrer metodene deres hver måned""

Taiichi Ohno (1946)

Omstillingsreduksjon - SMED:

- A - Observere og registrere alle aktivitetene som skjer i en omstilling
- B - Separere eksterne og interne aktiviteter
- C - Gjøre interne aktiviteter om til eksterne aktiviteter
- D - Strømlinjeforme alle aktivitetene

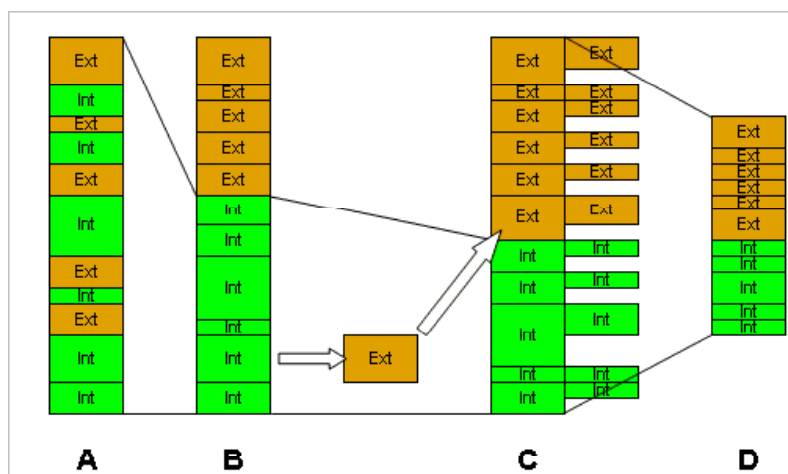

Refleksjon: Lean som en foss...

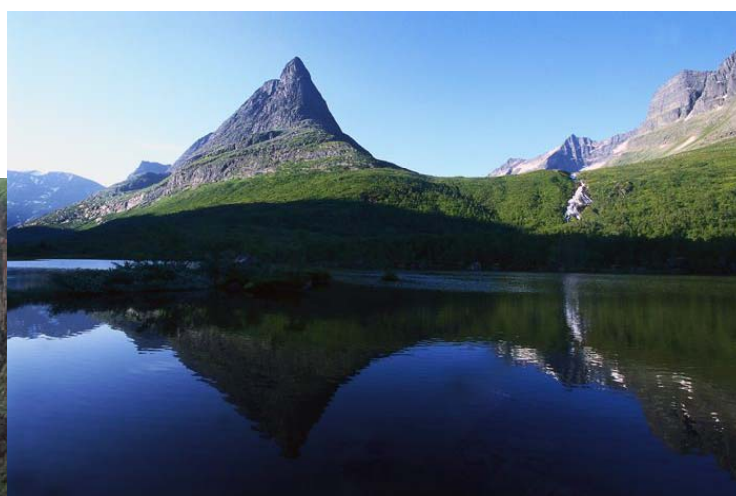

Et tale om lager: Innsjøen og steinene...

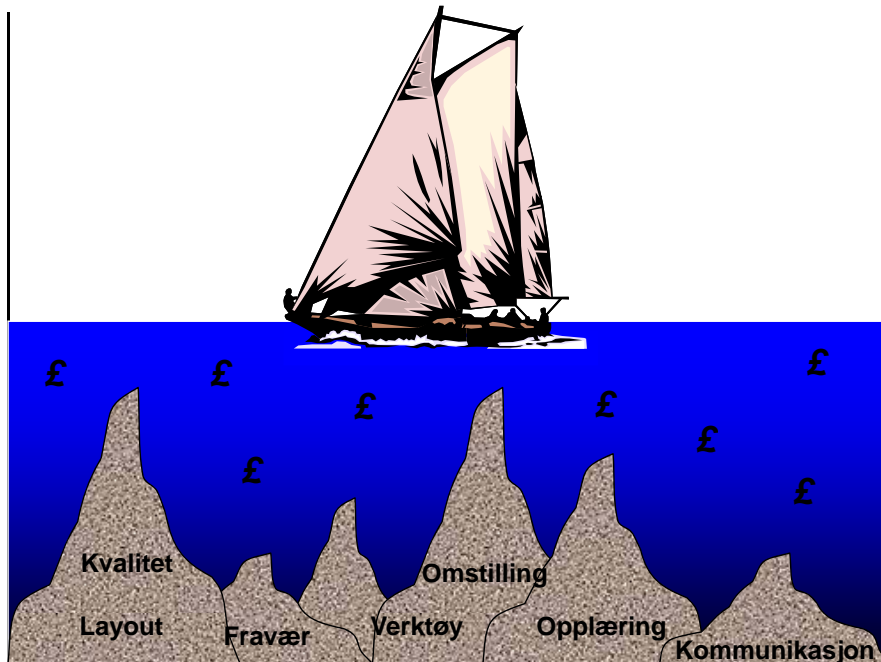

Spørsmål?!

