

Arkitektur for styringsmodell

SMARTLOG-Seminar

Trondheim, 1. september 2005

Ingvar Hagen

Agenda

- Bakgrunn
- Anvendt verktøy/software
- Eksempel
- Veien videre

Styringsmodeller

- ❑ En styringsmodell er en abstraksjon av en bedrift eller verdikjede som viser hvordan produksjon og logistikk er organisert og styrt.
- ❑ Modellen beskriver en AS-IS eller TO-BE status.
- ❑ Skap felles forståelse ved å sette sammen det beste fra ulike prinsipp, system og metoder til en behovsstyrt, spesifikk løsning
- ❑ Lag bilder og figurer, tegn og fortell

Bakgrunn for utvikling av verktøy

- Ha icon/figurer som er **illustrative** og **intuitive**
- Få tegnejobben til å bli vesentlig **raskere** å gjennomføre
- Enklere å **sammenligne ulike case** opp mot hverandre
- Bedrifter har **informasjonen tilgjengelig**, og kan lettere organisere den etter denne malen

Anvendt verktøy; Microsoft Visio

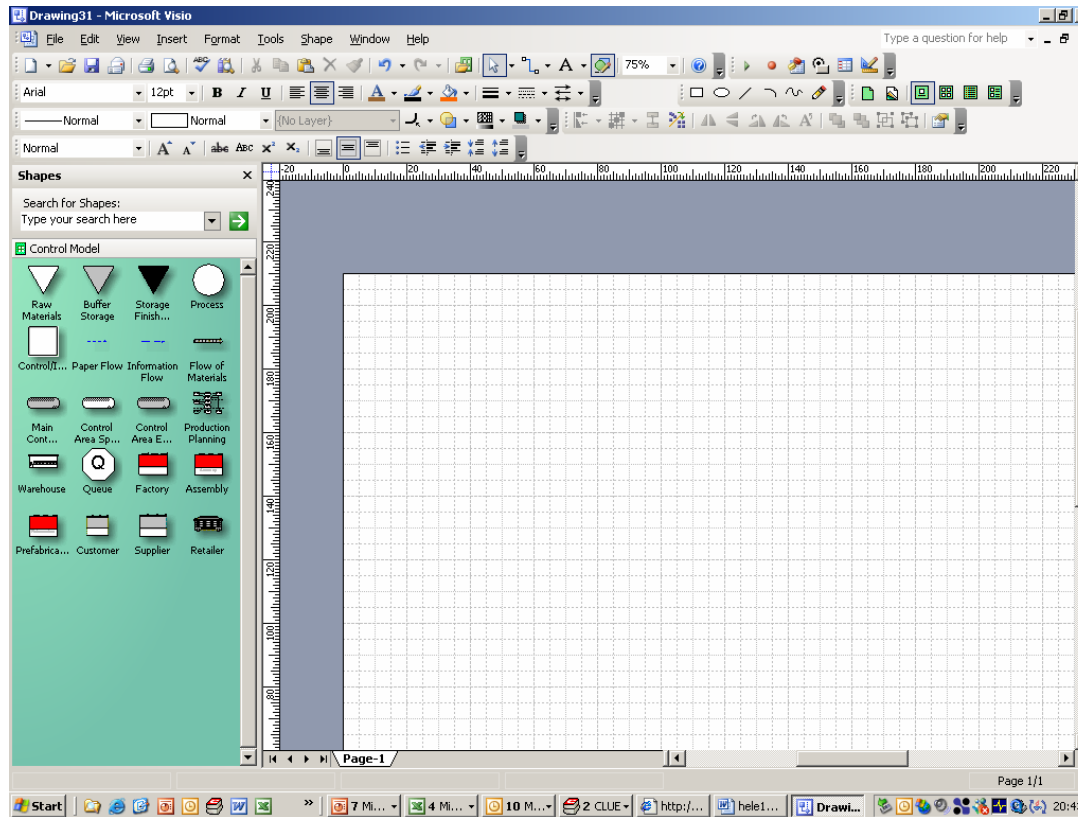

- ❑ Et sett av figurer/icon er lagret som egne "shapes"
- ❑ "Drag and drop" funksjonalitet

De 6 perspektivene fra Styringsmodell

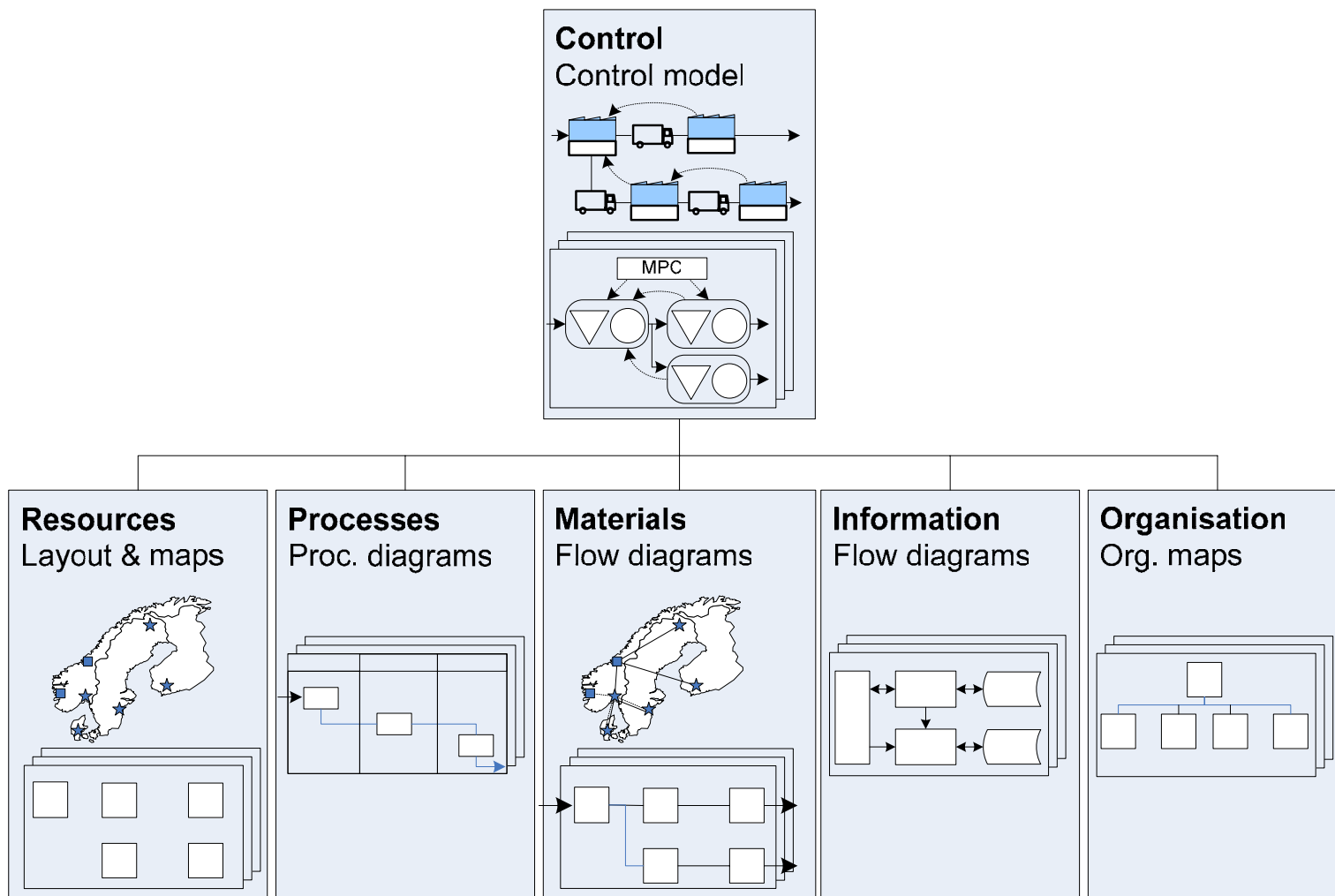

Test - bedrifter

Verktøyet er blitt testet/benyttet i 7 pågående prosjekter;

- Hydro
- Pipelife
- Protex
- Hagen Treindustri
- HÅG
- RCT
- Gilde Norsk Kjøtt

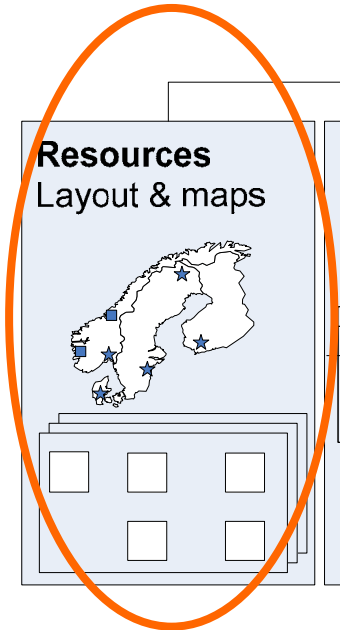
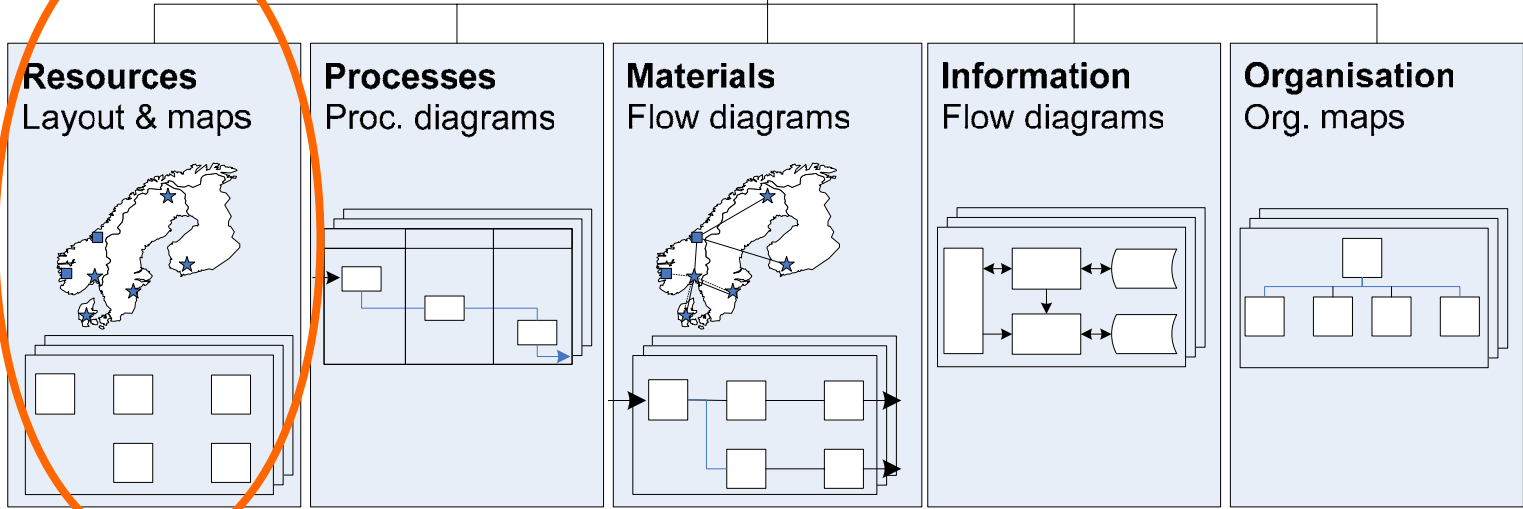
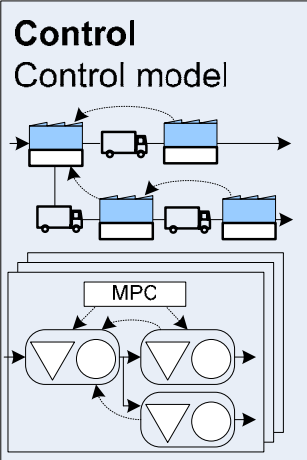

Ressurser - Lokasjon

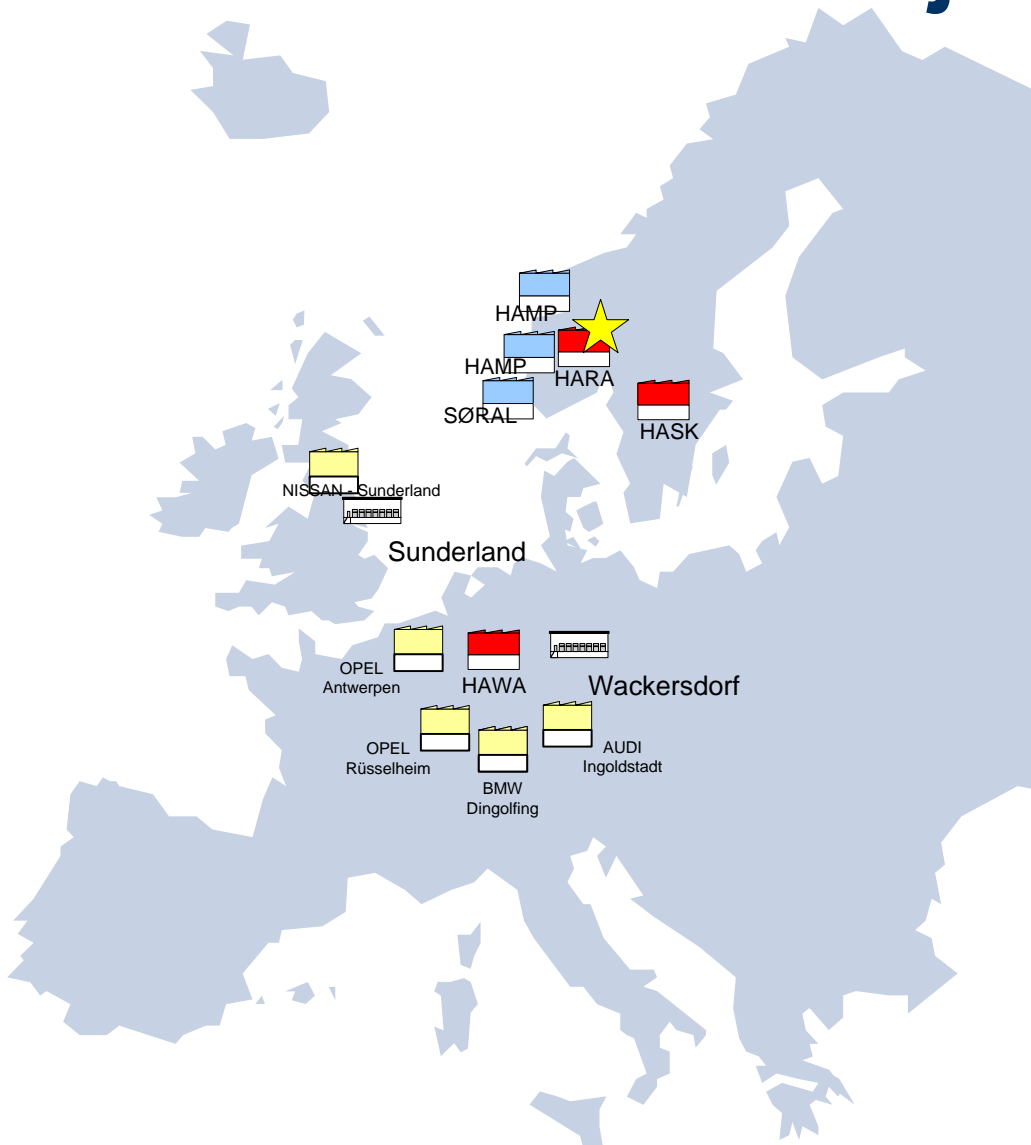

Eksempel fra Hydro

Ressurser - Layout

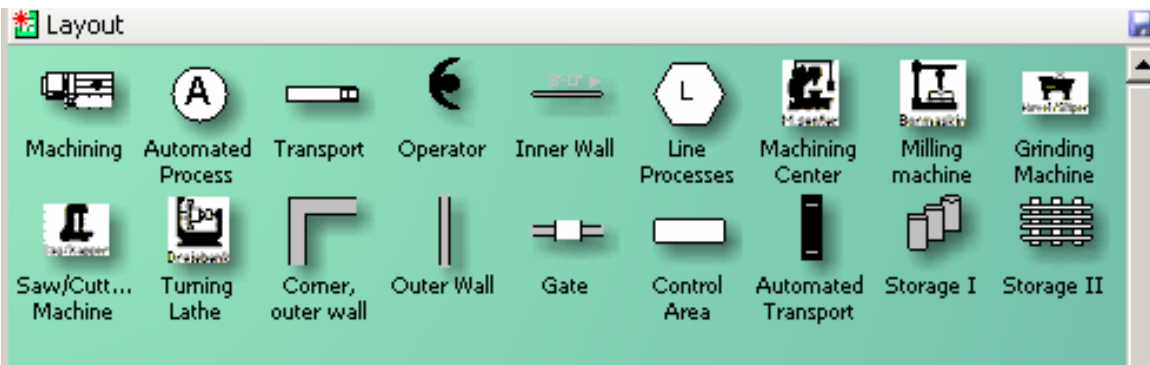
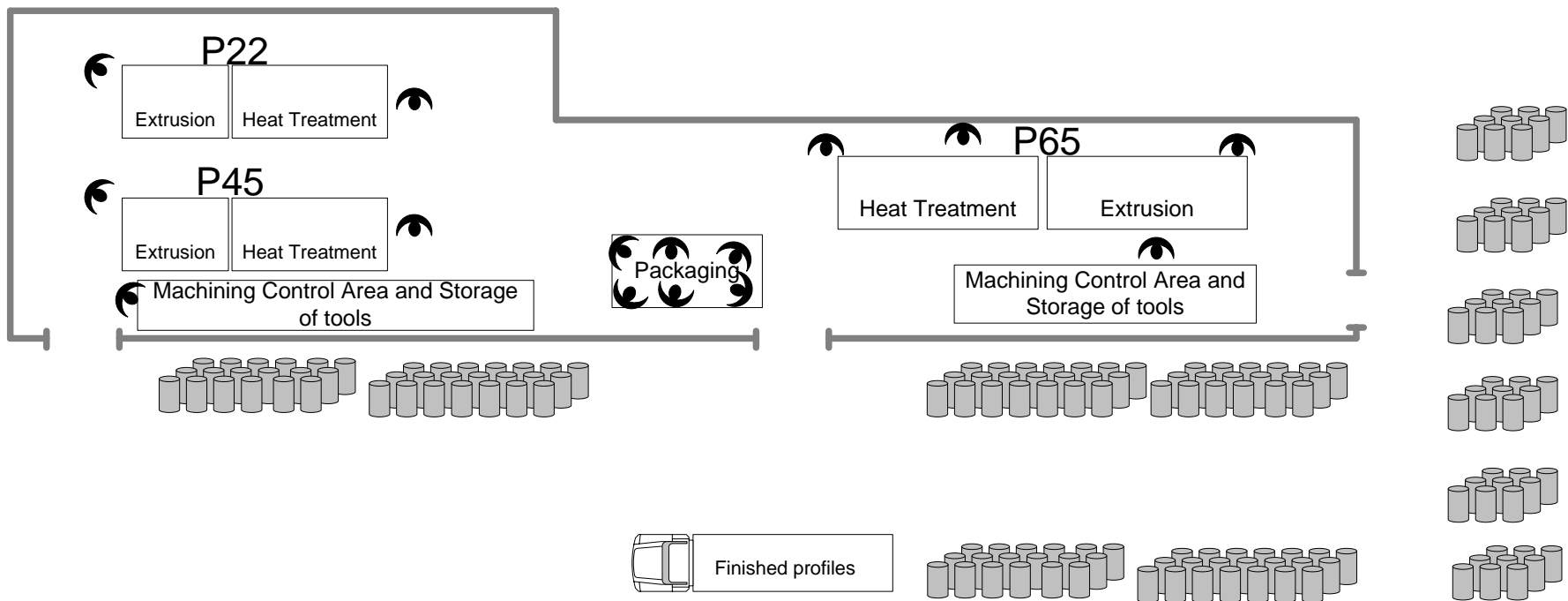

Eksempel fra
Hydro, HARA - N

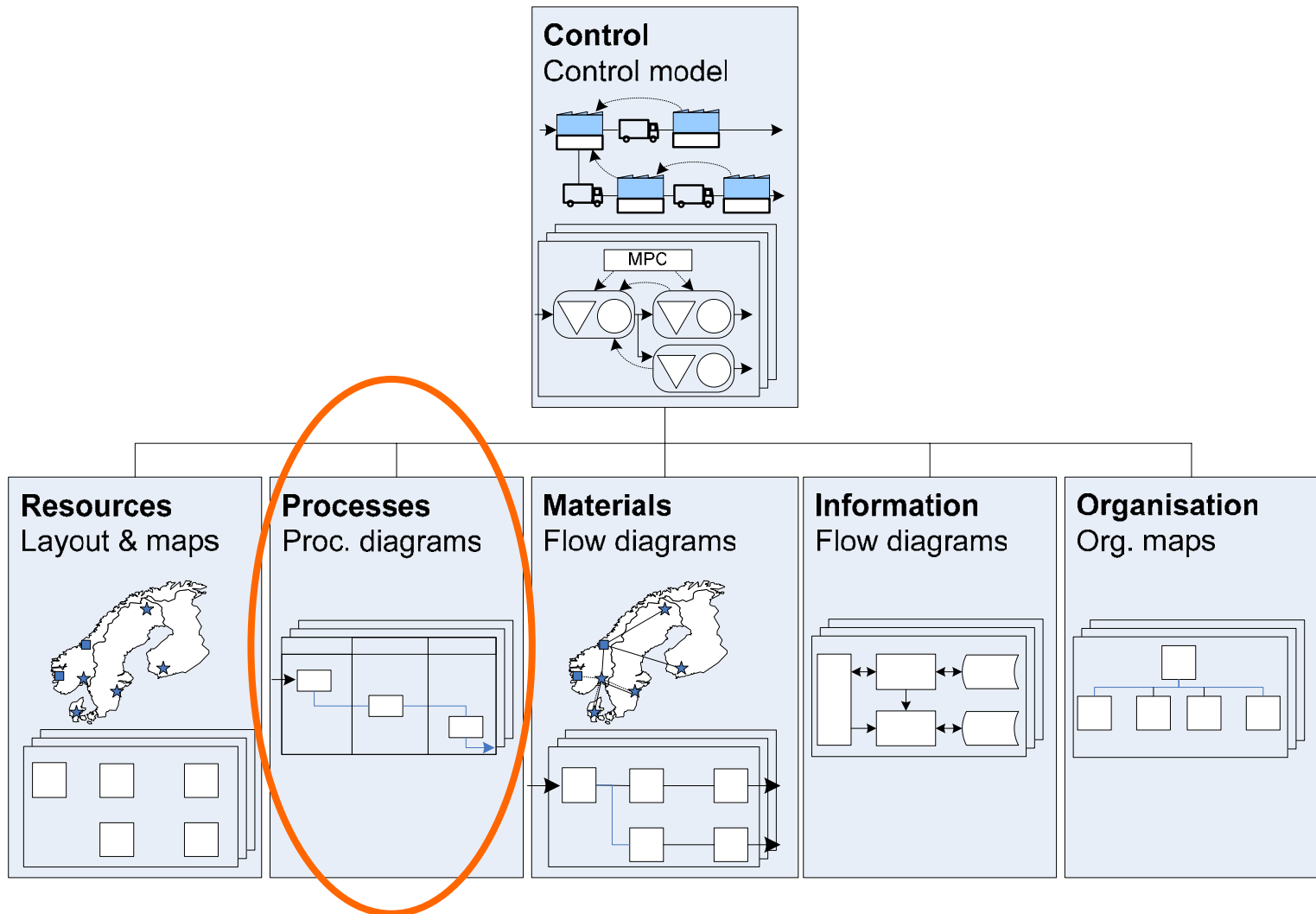

Prosesser - Administrative

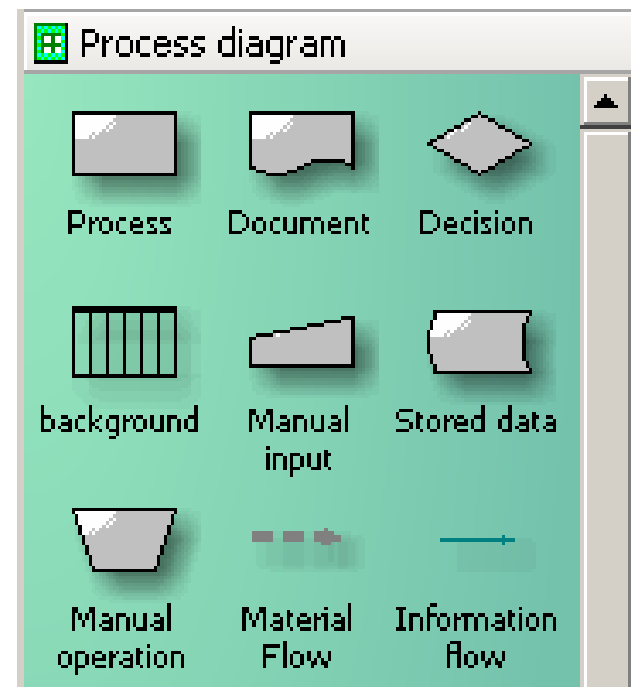
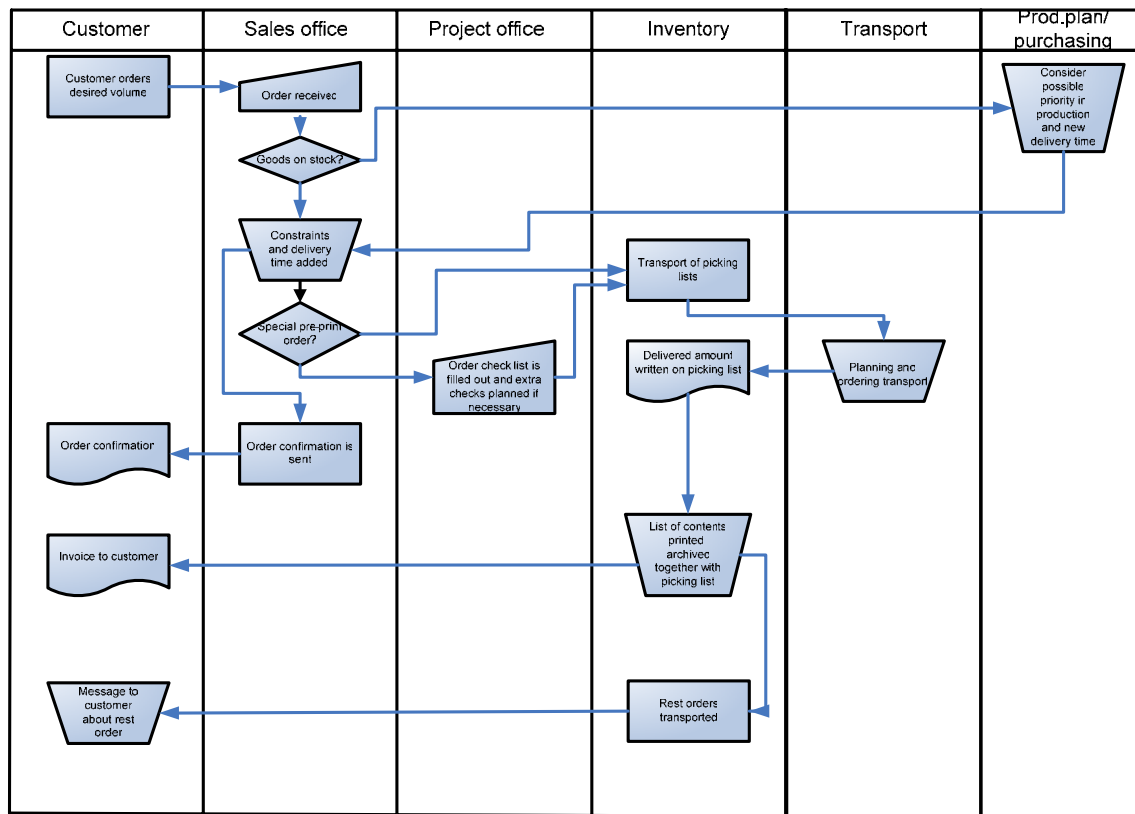

Eksempel fra Pipelife

Prosesser - Produksjon

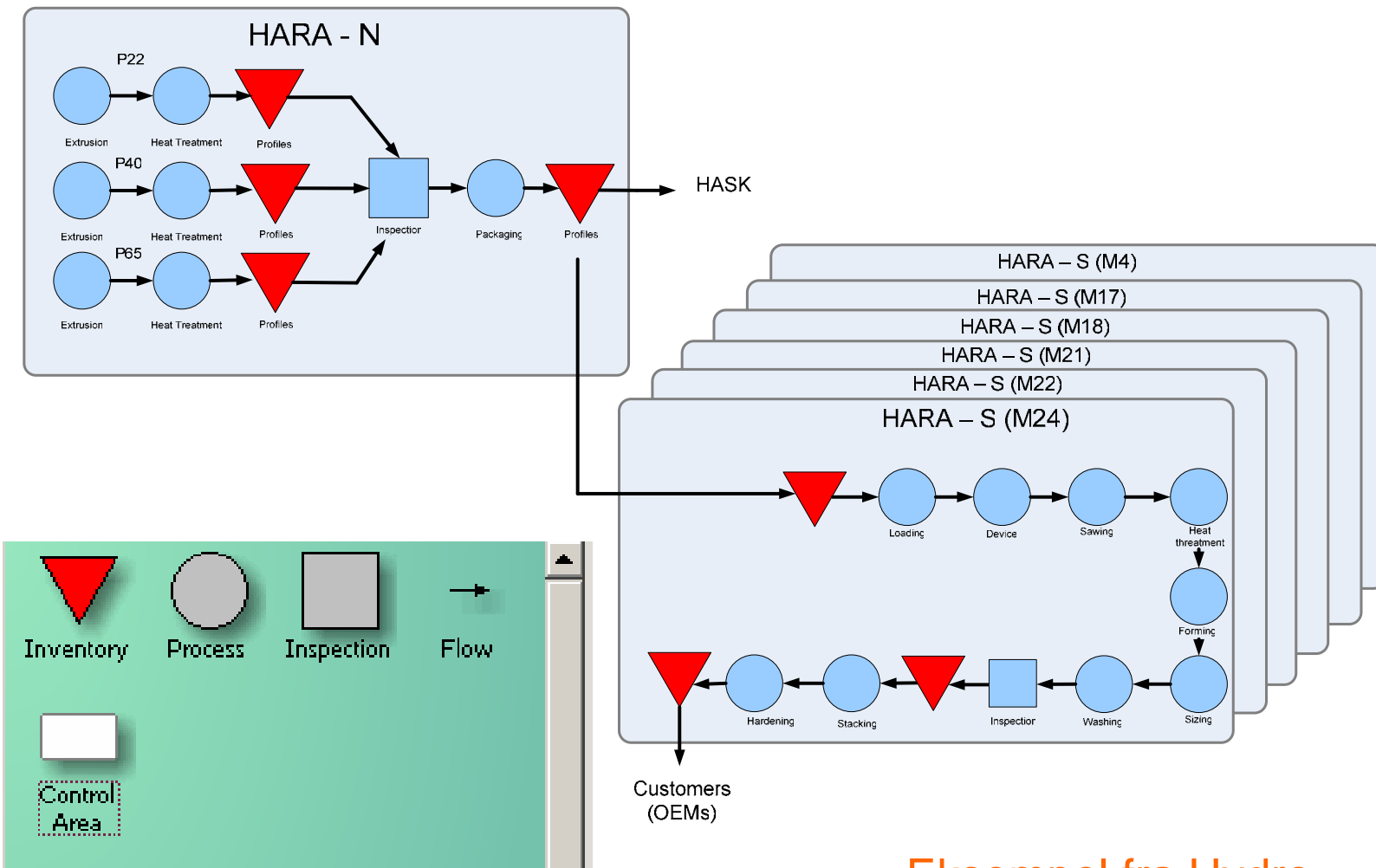

Eksempel fra Hydro

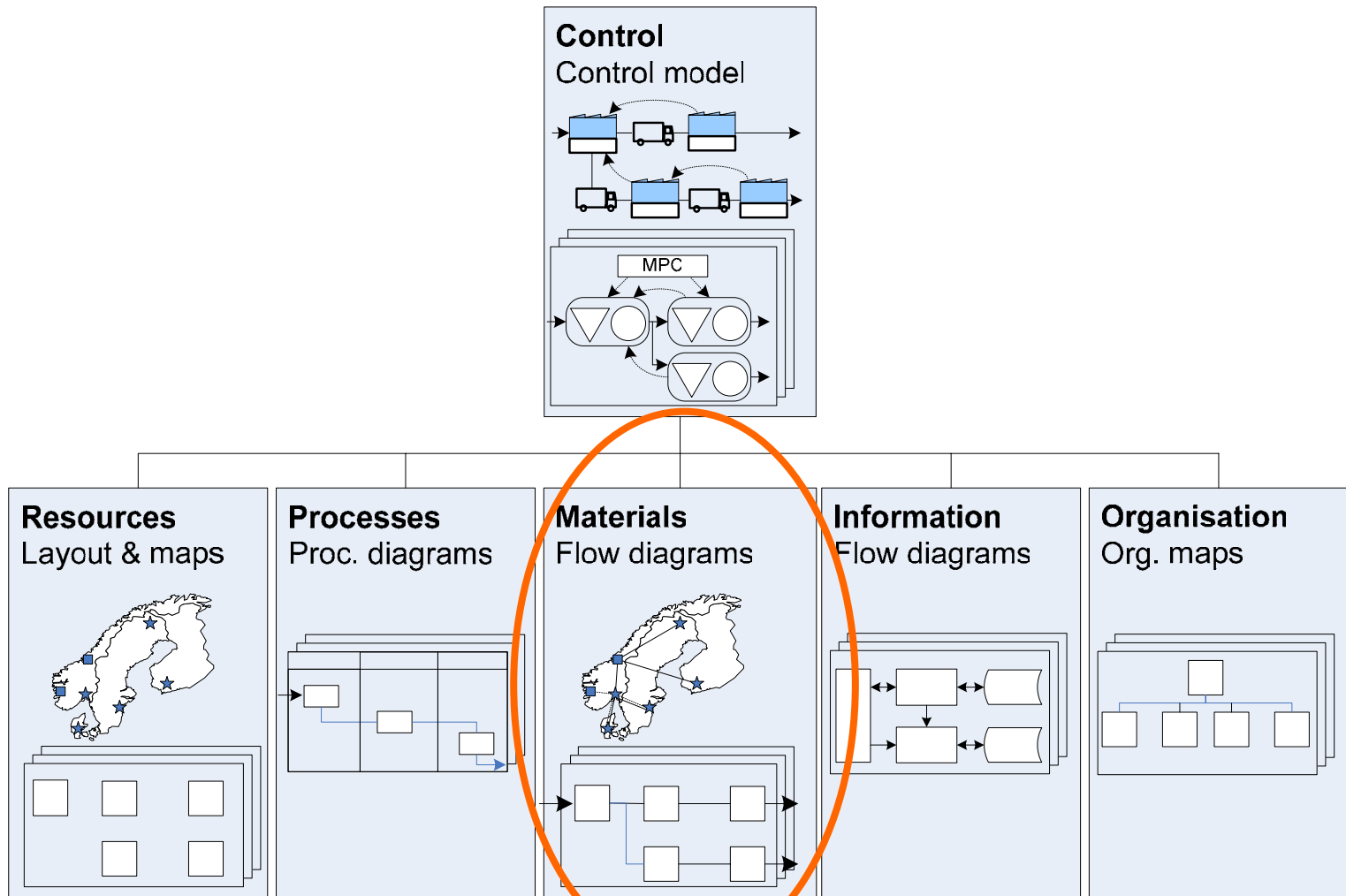

Material - materialflyt

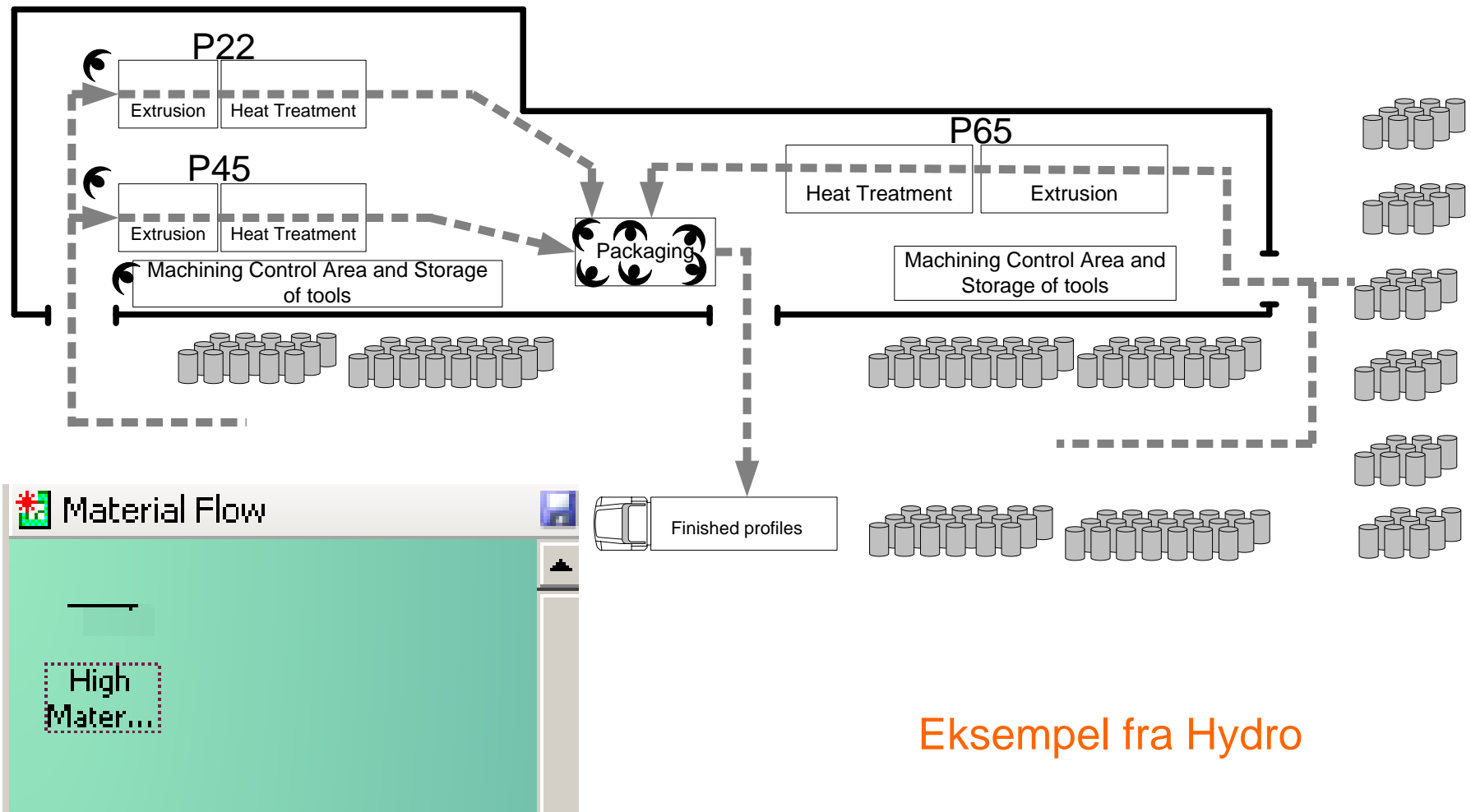

Eksempel fra Hydro

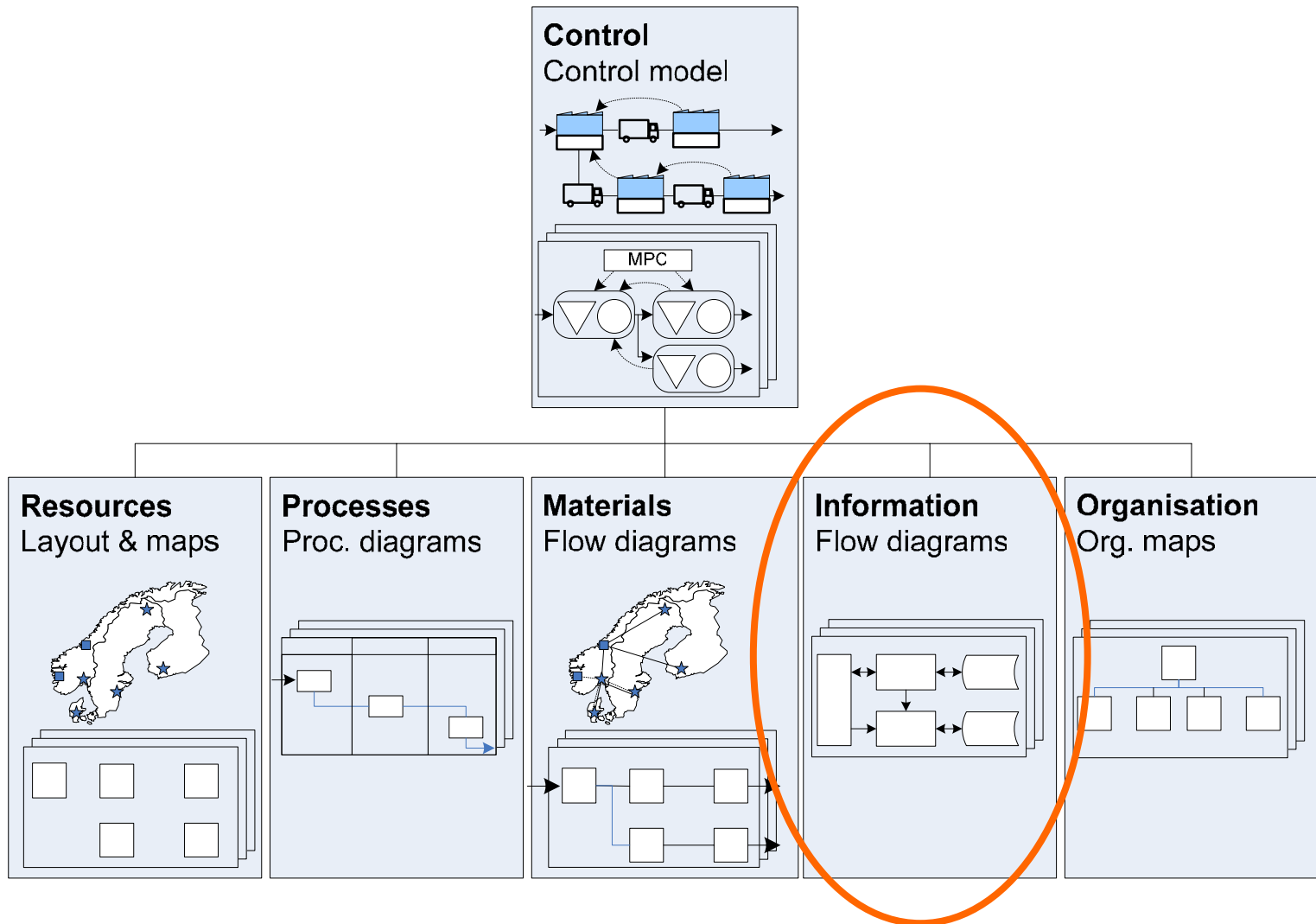

Informasjon - Informasjonsflyt

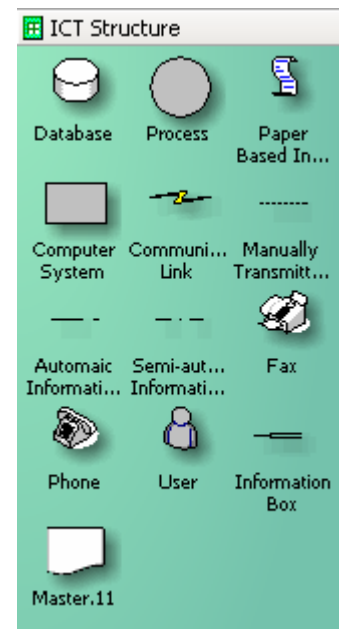
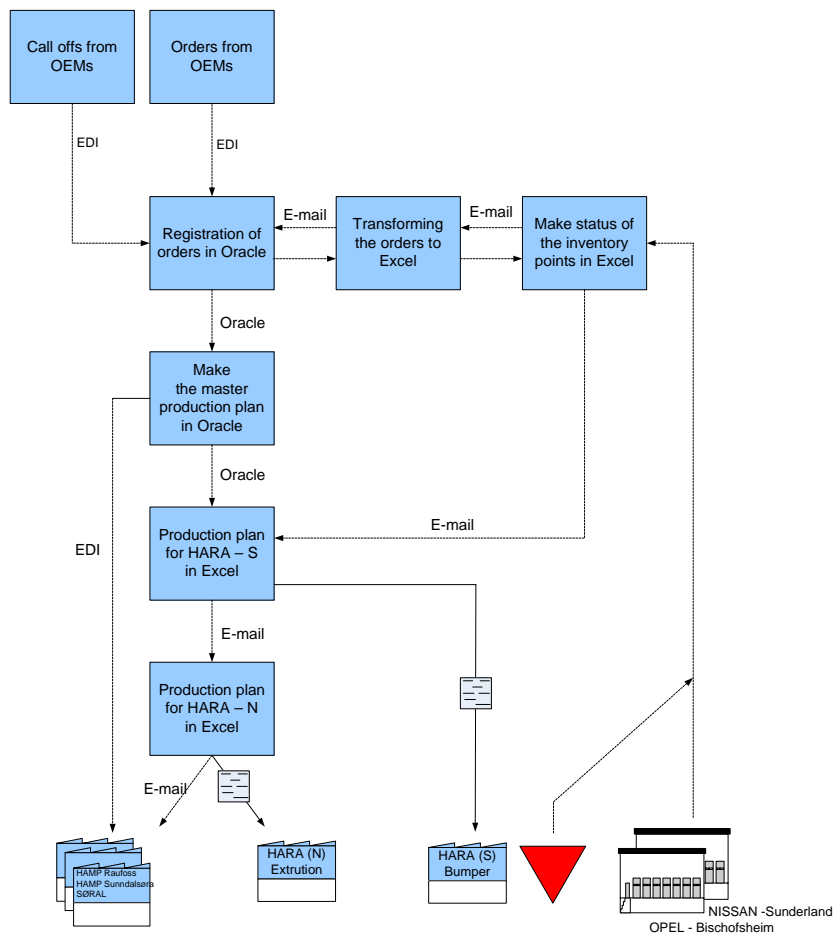

Eksempel fra Hydro

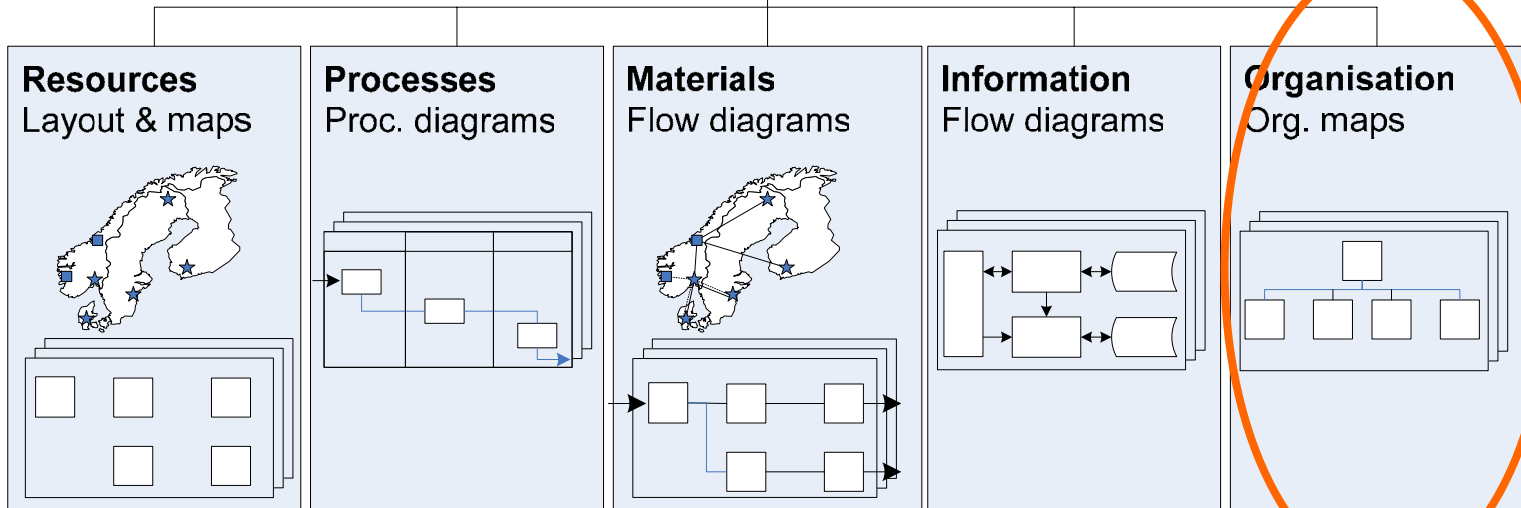
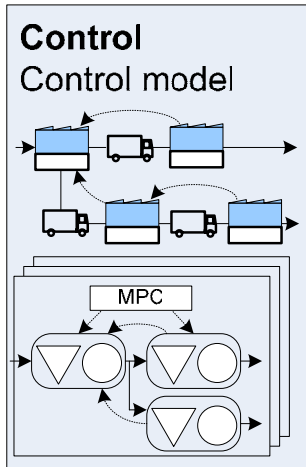

Organiasjon – Org. kart

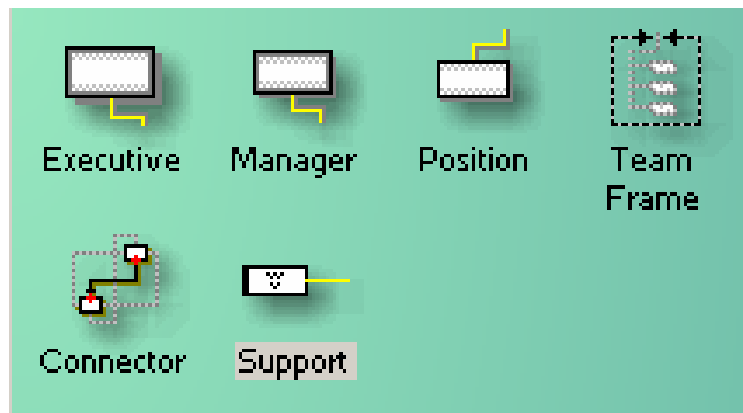
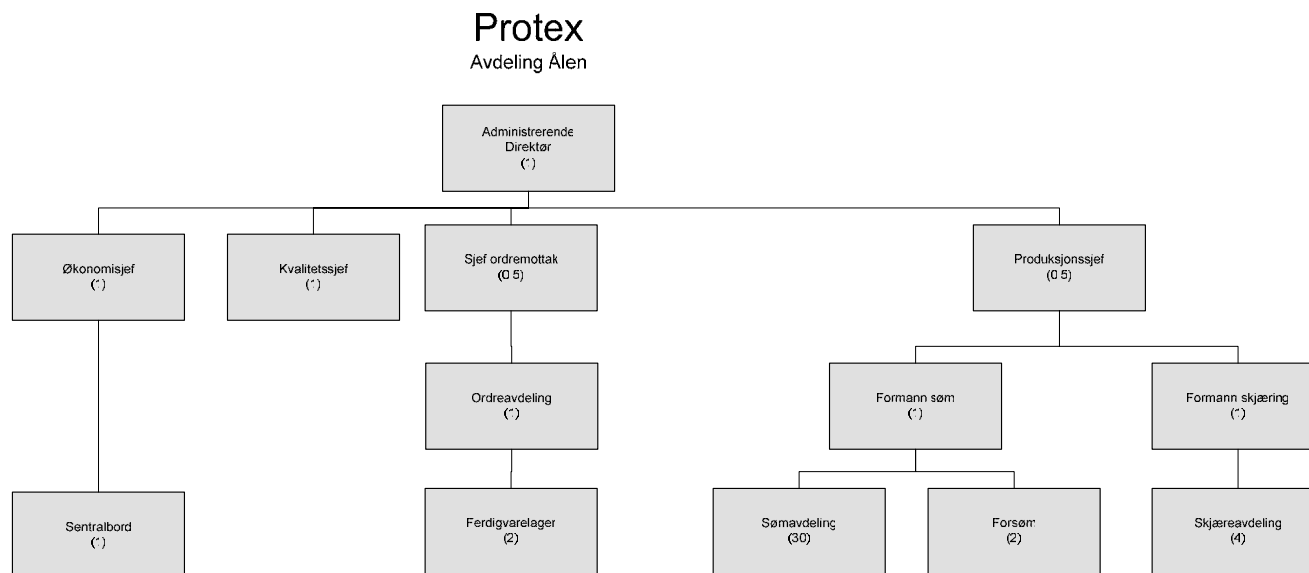

Eksempel fra Protex

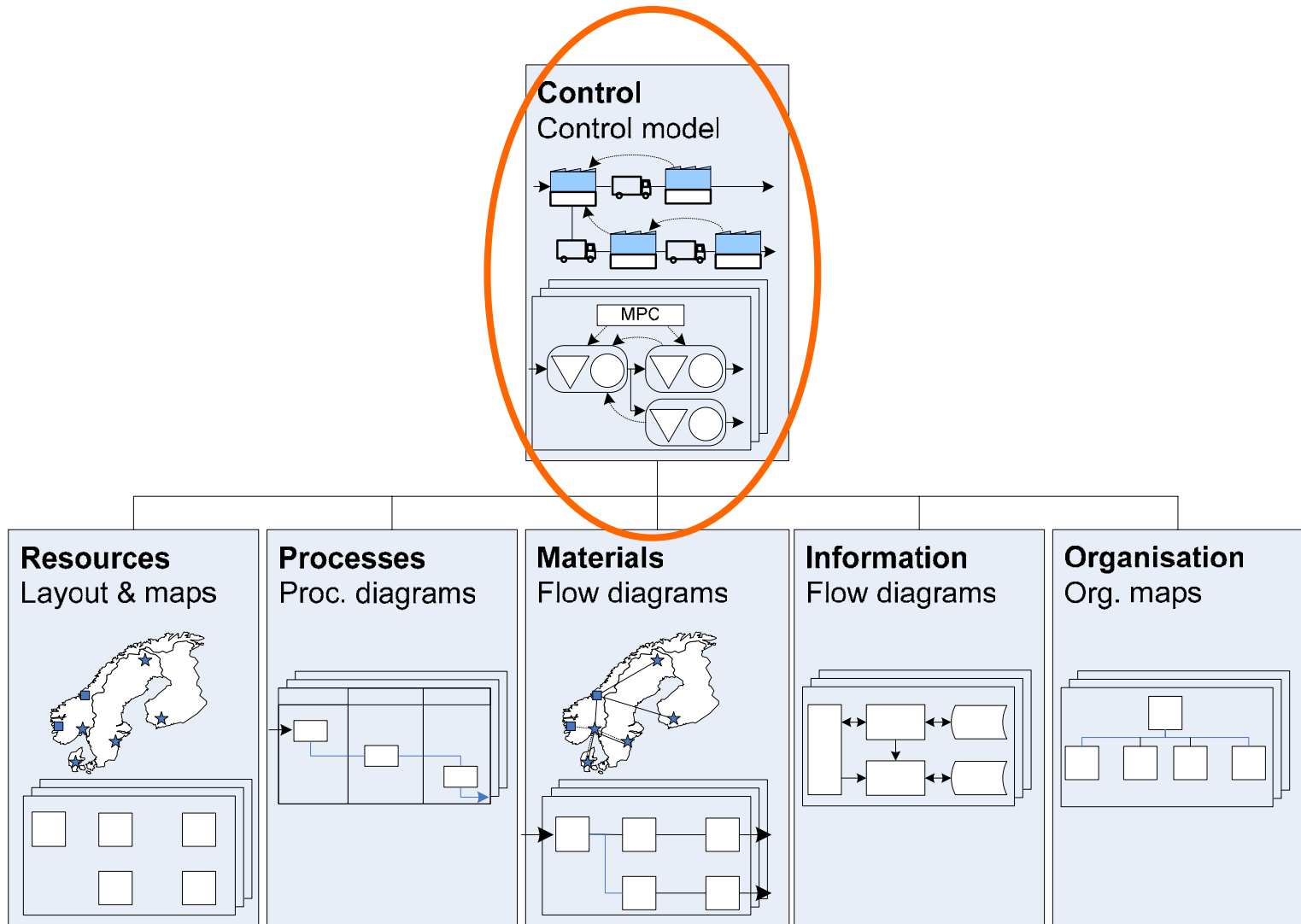

Styring – Styringsmodell (I)

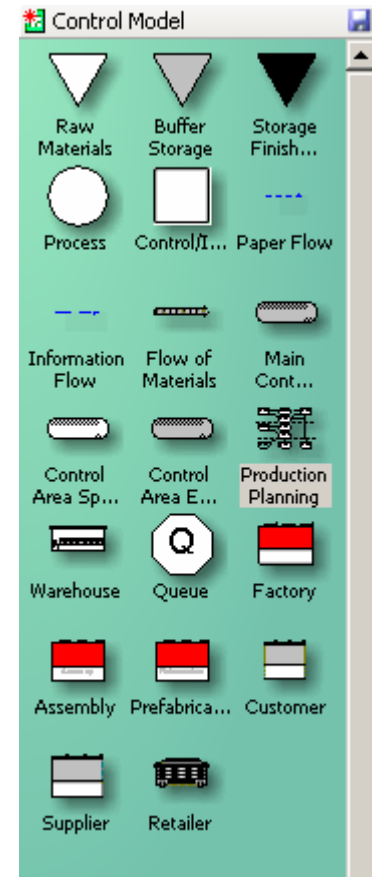
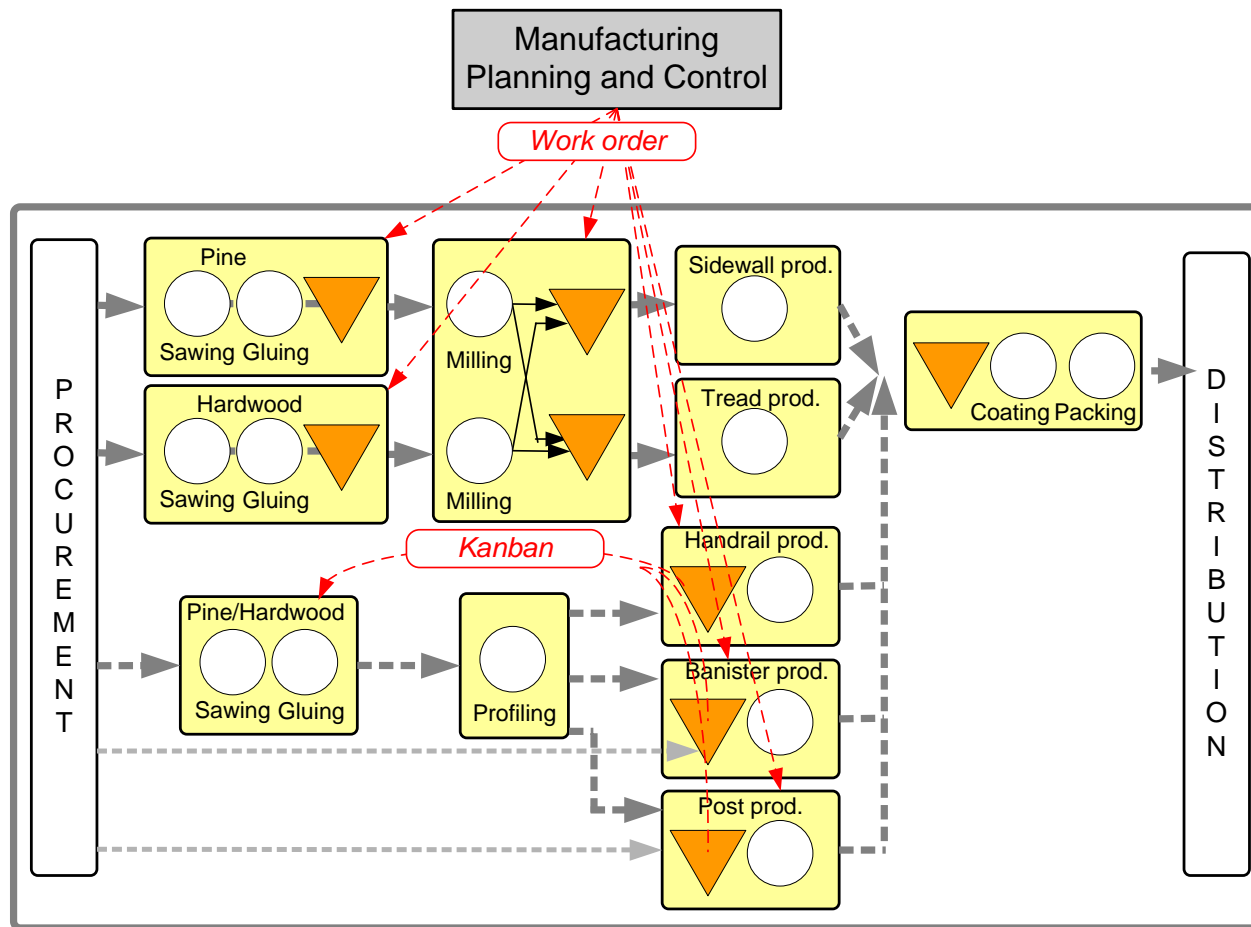

Eksempel fra Hagen Treindustri

Styring – Styringsmodell (II)

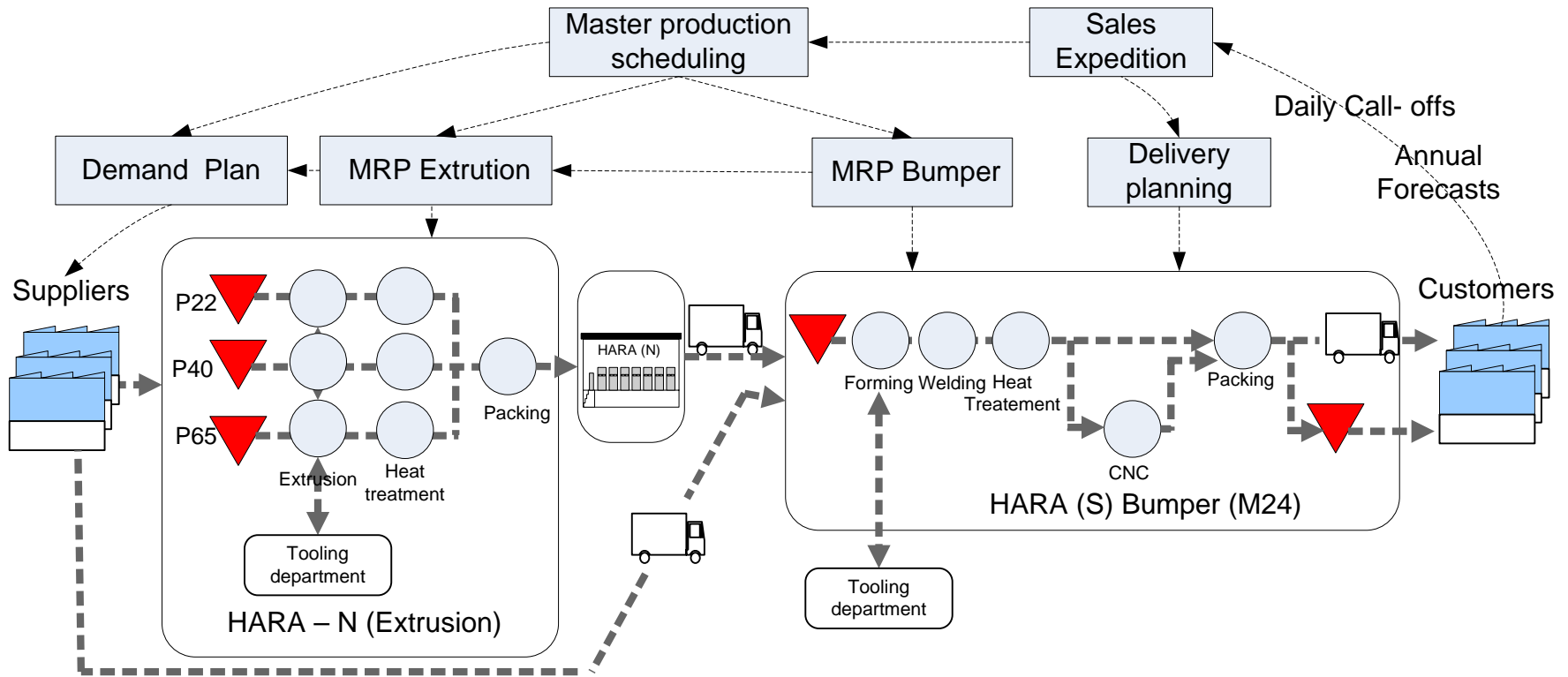

Eksempel fra Hydro

Videre arbeid

- Utarbeide et enda mer komplett sett av icon/figurer
- Sammenligne bedrifter med hverandre
- La bedriftene få tilgang til verktøyet