



Sebastian Teir, Jens Hetland, Erik Lindeberg, Asbjørn Torvanger, Katarina Buhr, Tiina Koljonen, Jenny Gode, Kristin Onarheim, Andreas Tjernshaugen, Antti Arasto, Marcus Liljeberg, Antti Lehtilä, Lauri Kujanpää & Matti Nieminen

## Potential for carbon capture and storage (CCS) in the Nordic region



# **Potential for carbon capture and storage (CCS) in the Nordic region**

Sebastian Teir, Jens Hetland, Erik Lindeberg, Asbjørn Torvanger,  
Katarina Buhr, Tiina Koljonen, Jenny Gode, Kristin Onarheim,  
Andreas Tjernshaugen, Antti Arasto, Marcus Liljeberg, Antti Lehtilä,  
Lauri Kujanpää & Matti Nieminen

ISBN 978-951-38-7661-6 (soft back ed.)

ISSN 1235-0605 (soft back ed.)

ISBN 978-951-38-7662-3 (URL: <http://www.vtt.fi/publications/index.jsp>)

ISSN 1455-0865 (URL: <http://www.vtt.fi/publications/index.jsp>)

Copyright © VTT 2010

JULKAISIJA – UTGIVARE – PUBLISHER

VTT, Vuorimiehentie 5, PL 1000, 02044 VTT

puh. vaihde 020 722 111, faksi 020 722 4374

VTT, Bergsmansvägen 5, PB 1000, 02044 VTT

tel. växel 020 722 111, fax 020 722 4374

VTT Technical Research Centre of Finland, Vuorimiehentie 5, P.O. Box 1000, FI-02044 VTT, Finland  
phone internat. +358 20 722 111, fax +358 20 722 4374

Cover photo "Mongstad City" by Svein-Jørgen Wiken

Text formatting Raija Sahlstedt

Edita Prima Oy, Helsinki 2010

Sebastian Teir, Jens Hetland, Erik Lindeberg, Asbjørn Torvanger, Katarina Buhr, Tiina Koljonen, Jenny Gode, Kristin Onarheim, Andreas Tjernshaugen, Antti Arasto, Marcus Liljeberg, Antti Lehtilä, Lauri Kujanpää & Matti Nieminen. Potential for carbon capture and storage (CCS) in the Nordic region. Espoo 2010. VTT Tiedotteita – Research Notes 2556. 188 p. + app. 28 p.

**Keywords** CCS, Nordic countries, capture, storage, CO<sub>2</sub>, emission, infrastructure

## Abstract

The objective of this study is to give an overview of the potential for applying CCS in the Nordic countries (Sweden, Finland, Denmark, Norway and Iceland). The realistic potential of CCS in the region has been evaluated by taking into account existing and future energy systems and policies, emission sources, potential storage sites, technological, economical and political constraints as well as public acceptance. Special attention has been given to identifying promising regional CCS solutions that would have a significant CO<sub>2</sub> emission reduction potential and could possibly involve cooperation between Nordic countries with synergical benefits for these.

The report includes mapping of CO<sub>2</sub> emissions in the Nordic countries from major sources, mapping and quantification of storage possibilities as well as scenarios of possible future CCS deployment in the region. In addition to the mapping, an overview of relevant CCS technology development and R&D activities in the Nordic countries is given. Public awareness of CCS, energy and climate policy frameworks, as well as political issues relevant to the deployment of CCS in the Nordic countries are also addressed.

## **Preface**

This work was ordered and funded by the Nordic Innovation Centre. The work was carried out by a consortium consisting of VTT Technical Research Centre of Finland, IVL Swedish Environmental Research Institute, SINTEF, and CICERO Center for International Climate and Environmental Research – Oslo. The project was coordinated by VTT.

# Contents

Abstract .....	3
Preface .....	4
<b>1. Introduction.....</b>	<b>11</b>
1.1 Objective of the study .....	12
<b>2. CO<sub>2</sub> emissions in the Nordic countries.....</b>	<b>14</b>
2.1 Finland.....	15
2.2 Denmark.....	17
2.3 Sweden.....	18
2.4 Norway .....	19
2.5 Iceland.....	20
2.6 Summary and comparison of the Nordic countries .....	21
<b>3. CCS technologies suitable for Nordic conditions .....</b>	<b>24</b>
3.1 CO <sub>2</sub> capture .....	24
3.1.1 Post-combustion capture .....	27
3.1.2 Pre-combustion capture .....	29
3.1.3 Oxy-fuel combustion .....	31
3.1.4 Pre-conditioning and CO <sub>2</sub> compression.....	32
3.1.5 Future capture technologies.....	33
3.2 CO <sub>2</sub> transportation .....	34
3.3 CO <sub>2</sub> storage .....	35
3.3.1 Storage of CO <sub>2</sub> in underground geological formations .....	36
3.3.2 CO <sub>2</sub> storage by mineralization.....	38
3.4 CO <sub>2</sub> capture applied to combined heat and power (CHP) plants .....	41
3.5 Carbon capture in process industry .....	42
3.6 CCS retrofit and capture-ready power plants.....	43
3.7 CO <sub>2</sub> capture from biomass-fired installations .....	45
3.8 Maturity of CCS .....	45
3.9 Future improvement of CCS technologies.....	46
3.10 Selection guidelines for sector-wise appliance of CCS.....	49
3.10.1 General selection guidelines .....	49
<b>4. Capacities for carbon dioxide storage in the Nordic countries.....</b>	<b>53</b>
4.1 Data background and methods.....	53
4.1.1 Methodology for aquifers.....	54
4.1.2 Methodology for depleted gas reservoir .....	57
4.2 Capacity estimates .....	58
4.2.1 Storage capacity in Norway .....	58

4.2.2	Storage capacity in Denmark .....	63
4.2.3	Storage capacity in Finland .....	66
4.2.4	Storage capacity in Iceland .....	66
4.2.5	Storage capacity in Sweden .....	66
4.3	Suitable minerals for mineral carbonation .....	68
4.3.1	Calcium silicates .....	69
4.3.2	Magnesium silicates .....	69
4.3.3	Basalt .....	72
4.4	Summary .....	73
<b>5.</b>	<b>Overview of CCS projects within research, technology development and demonstration .....</b>	<b>74</b>
5.1	Current CCS operations .....	74
5.1.1	Sleipner .....	75
5.1.2	In Salah .....	77
5.1.3	Snøhvit .....	78
5.1.4	Weyburn .....	79
5.2	Large-scale CCS projects under planning .....	80
5.2.1	Meri-Pori project .....	81
5.2.2	Nordjyllandsværket .....	82
5.2.3	Mongstad CCS project and the TCM .....	82
5.2.3.1	Mongstad TCM .....	82
5.2.4	CarbFix project .....	83
5.2.5	Kårstø project .....	83
5.3	Research and demonstration projects .....	83
5.4	Nordic CCS R&D projects and programmes .....	85
5.5	European R&D projects .....	86
5.5.1	ULCOS .....	87
5.5.2	GeoCapacity .....	88
5.5.3	MOVECBM .....	89
5.5.4	Storage R&D projects .....	89
<b>6.</b>	<b>Economic and political frameworks for CCS .....</b>	<b>90</b>
6.1	Overview of policies on future use of fossil fuels and emission reduction commitments in the Nordic countries .....	91
6.1.1	Nordic energy statistics .....	91
6.1.2	Denmark .....	93
6.1.3	Finland .....	95
6.1.4	Sweden .....	97
6.1.5	Norway .....	99
6.1.6	Iceland .....	100



6.1.7	Summary.....	101
6.2	Status of EU regulation on CCS and impacts on the Nordic countries .....	102
6.2.1	Regulation and crediting of storage activities.....	102
6.2.2	EU funding for demonstration projects.....	103
6.2.3	State aid rules.....	104
6.2.4	Infrastructure planning .....	104
6.3	Timeline for political processes with regards to the implementation of CCS and involvement of industrial players .....	105
6.3.1	Denmark .....	105
6.3.2	Finland.....	105
6.3.3	Iceland .....	105
6.3.4	Norway.....	106
6.3.5	Sweden.....	106
6.4	Identification of stakeholders .....	106
6.5	Summary .....	107
<b>7.</b>	<b>Public awareness and acceptance for CCS.....</b>	<b>109</b>
7.1	Overview of public opinion research.....	110
7.2	Communication and dialogue .....	115
<b>8.</b>	<b>Future role for CCS in the Nordic countries.....</b>	<b>118</b>
8.1	Scenario studies evaluating future CCS adaptation.....	118
8.1.1	Modelling approach.....	119
8.1.2	Scenario descriptions.....	120
8.1.3	Scenarios for the future CCS adaptation.....	120
8.2	Regional potential for CCS adaptation.....	126
8.2.1	Helsinki region (FI).....	128
8.2.2	Northern shore of the Gulf of Bothnia (FI, SE) .....	129
8.2.3	South-western coast line of Finland (FI).....	131
8.2.4	Imatra region (FI) .....	132
8.2.5	Mid-eastern coast line of Sweden (SE).....	133
8.2.6	Stockholm region (SE) .....	134
8.2.7	Oxelösund region (SE).....	135
8.2.8	Gotland region (SE) .....	136
8.2.9	South-east region of Sweden (SE).....	137
8.2.10	Göteborg region (SE).....	138
8.2.11	Belt region (DK) .....	139
8.2.12	Öresund region (DK, SE) .....	141
8.2.13	Aalborg region (DK) .....	141
8.2.14	Esbjerg CHP plant (DK) .....	142
8.2.15	Melkøya LNG plant (NO).....	143

8.2.16	Mid-west region of Norway (NO)	143
8.2.17	South-east region of Norway (NO)	145
8.2.18	South-west region of Norway (NO)	146
8.2.19	Western region of Iceland (IS)	147
8.2.20	Offshore regions (NO, DK)	148
8.2.21	Summary of the cluster study	149
8.3	Cost appraisals and timeline for technical realisation of systems	151
8.3.1	Impacts of fuel and technology	152
8.3.2	Impact of carbon tax	154
8.3.3	Cost of CO <sub>2</sub> transport	157
8.4	Rough scheme for CCS deployment in the Nordic countries	159
<b>9.</b>	<b>Recommendations</b>	<b>162</b>
9.1	Recommendations for actions needed pertaining to timeline, technology priorities and infrastructure deployment	162
9.1.1	Typology and priorities of point sources	163
9.1.2	CCS applications for facilities emitting biogenic CO <sub>2</sub>	166
9.1.3	CCS applications for autonomous offshore power generation	166
9.1.4	CCS technology development	166
9.2	Economic and political actions needed for deployment of CCS	167
9.2.1	Policies on future use of fossil fuels and emission reduction commitments	167
9.2.2	EU regulation on CCS and impacts on Nordic countries	167
9.2.3	Timeline for political processes	168
9.2.4	Identification of stakeholders	168
9.3	Recommendations for a Nordic approach regarding public awareness about CCS	169
9.4	Summary – recommendations for topics in the upcoming research program on CCS	170
<b>10.</b>	<b>Summary</b>	<b>173</b>
	References	179

APPENDIX A1: FACILITIES WITH CO<sub>2</sub> EMISSIONS > 0.1 MT CO<sub>2</sub>/A IN 2007 – FINLAND  
APPENDIX A2: FACILITIES WITH CO<sub>2</sub> EMISSIONS > 0.1 MT CO<sub>2</sub>/A IN 2007 – DENMARK  
APPENDIX A3: FACILITIES WITH CO<sub>2</sub> EMISSIONS > 0.1 MT CO<sub>2</sub>/A IN 2007 – SWEDEN  
APPENDIX A4: FACILITIES WITH CO<sub>2</sub> EMISSIONS > 0.1 MT CO<sub>2</sub>/A IN 2007 – NORWAY  
APPENDIX A5: FACILITIES WITH CO<sub>2</sub> EMISSIONS > 0.1 MT CO<sub>2</sub>/A IN 2007 – ICELAND  
APPENDIX B1: MAP OF FACILITIES WITH CO<sub>2</sub> EMISSIONS > 0.1 MT CO<sub>2</sub>/A IN 2007 –  
ONLY FOSSIL CO<sub>2</sub> EMISSIONS VISIBLE  
APPENDIX B2: MAP OF FACILITIES WITH CO<sub>2</sub> EMISSIONS > 0.1 MT CO<sub>2</sub>/A IN 2007 –  
ONLY BIOGENIC CO<sub>2</sub> EMISSIONS VISIBLE  
APPENDIX B3. MAP OF FACILITIES WITH CO<sub>2</sub> EMISSIONS > 0.1 MT CO<sub>2</sub>/A IN 2007 –  
BOTH FOSSIL AND BIOGENIC CO<sub>2</sub> EMISSIONS VISIBLE  
APPENDIX B4: CLUSTERS OF FACILITIES WITH CO<sub>2</sub> EMISSIONS > 0.1 MT CO<sub>2</sub>/A IN 2007 –  
BOTH FOSSIL AND BIOGENIC CO<sub>2</sub> EMISSIONS VISIBLE  
APPENDIX C1. SUMMARY OF FOUR LARGE-SCALE CCS PROJECTS IN OPERATION  
APPENDIX C2. LARGE-SCALE CCS PROJECTS IN PREPARATION  
APPENDIX C3. RESEARCH AND DEMONSTRATION PROJECTS  
APPENDIX C4. NORDIC CCS R&D PROJECTS AND PROGRAMMES



# 1. Introduction

During the last two centuries the concentration of greenhouse gases<sup>1</sup> has increased as a result of human activities, which is considered to have an impact on the global climate change. Combustion of fossil fuels is the main source of anthropogenic CO<sub>2</sub> emissions (about three-quarters), but several industrial processes (such as oil refining and the manufacturing of cement, lime, and steel) are also significant sources of CO<sub>2</sub> emissions. The global annual anthropogenic CO<sub>2</sub> emissions were about 29 Gt CO<sub>2</sub> in 2007 (IEA 2009a).

According to IPCC (2007) a 50–85% reduction of the greenhouse gases from the present level by 2050 is needed to stabilise the global temperature rise to 2°C over the pre-industrial level. However, the global energy demand is steadily increasing due to increasing population and economic growth. Since most of the global energy demand is met by using fossil fuels, the CO<sub>2</sub> emissions are also expected to increase with existing global climate and energy policies. According to the commitments under the 1997 Kyoto Protocol, industrial countries should reduce their greenhouse gas emissions by an average of 5% from their 1990 levels during 2008–2012. However, there is yet no global agreement on emission commitments after the Kyoto period expires.

EU has endorsed an ambitious climate and energy policy for mitigating the climate change and increase EU's energy security. EU has set a series of demanding targets<sup>2</sup> for Member States to be met by 2020. As members of EU, these targets also apply to Finland, Sweden and Denmark. However, Norway and Iceland are also subjected to international political pressure to reduce greenhouse gas emissions.

---

<sup>1</sup> Most importantly CO<sub>2</sub>, but also methane, nitrous oxide, and fluorinated gases.

<sup>2</sup> These include a reduction in EU greenhouse gas emissions of at least 20%, an increase of renewable energy sources to 20% of the total energy use, and a 20% reduction in primary energy use by improved energy efficiency.

Although significant technological developments in reducing carbon dioxide emissions have been achieved during recent decades, all available technologies and methods will be needed. Technological options for the reduction of emissions include more effective energy use, improved energy conversion technologies, a shift to low-carbon or renewable biomass fuels, a shift to nuclear power, improved energy management, the reduction of industrial by-product and process gas emissions, and carbon capture and storage (CCS).

CCS is considered to be one of the main technologies for reducing CO<sub>2</sub> emissions and its development is encouraged by several developed countries and unions, such as EU, U.S., Norway, Australia and large developing countries, such as China and India. In CCS the carbon from fossil fuels is separated as a concentrated CO<sub>2</sub> stream from a stationary source, such as a power plant, and stored in isolation from the atmosphere in suitable storage locations. Carbon dioxide can also be captured from gases from chemical processes. The cost of capturing CO<sub>2</sub> from such large-scale emission sources is much less than from distributed sources, such as transport vehicles, or directly from the atmosphere. The separated CO<sub>2</sub> is compressed and transported by pipeline or tankers to the storage site. Suitable storage sites are exhausted oil and gas fields or other subsurface geological formations, such as saline aquifers. Captured CO<sub>2</sub> is also injected into depleting oil wells for enhancing the oil recovery from these wells.

The rapid ongoing development of CCS may provide an opportunity for the Nordic countries, where both large stationary sources of CO<sub>2</sub> and geology suitable for storage of CO<sub>2</sub> can be found. The new EU directive on geological storage enables transboundary CO<sub>2</sub> transportation (EC, 2009) for both Member States and members of the European Economic Area, which includes Norway and Iceland. This gives a common regulatory foundation for developing an infrastructure for CCS, not only for EU Member States, but also for the Nordic countries. Crucial aspects to handle when considering CCS are capture (and compression), transport, storage, monitoring, risk assessment, legal and regulatory framework, and last but not least the financial aspects pertaining to deployment of CCS at large scale.

### **1.1 Objective of the study**

The objective of this study is to give an overview of the potential for applying CCS in the Nordic countries. The realistic potential of CCS in the region has been evaluated by taking into account the existing and future energy systems and

policies, emission sources, potential storage sites, technological, economical and political constraints as well as public acceptance. The technology overview includes CCS applications for the power and heat sector as well as for other process industries (e.g. steel plants, cement plants), pulp and paper industry and fuel extraction and refining. Special attention was given to identifying promising regional CCS solutions that could have a significant CO<sub>2</sub> emission reduction potential and could possibly involve several Nordic countries with synergy benefits.

The report includes mapping of CO<sub>2</sub> emissions in the Nordic countries from major sources, mapping and quantification of storage possibilities as well as scenarios of the needed infrastructure in the short (2020) and long term (2050) in the region. Except for the mapping, an overview of relevant CCS technology development and R&D activities in the Nordic countries is given. Public awareness of CCS, energy and climate policy frameworks, as well as political issues relevant to the deployment of CCS in the Nordic countries are addressed.

Based on the results from this study, a set of recommendations is given for topics that could be addressed by the upcoming Top-level Research Initiative on CCS.

## 2. CO<sub>2</sub> emissions in the Nordic countries

In order to assess the potential for applying CCS to existing facilities, a database over the largest CO<sub>2</sub> emitting facilities in the Nordic countries was made. The database includes both biogenic<sup>3</sup> and fossil or mineral CO<sub>2</sub> emissions from facilities emitting annually over 0.1 Mt CO<sub>2</sub>. The database has been constructed using emission data for the year 2007 from the European Pollutant Release and Transfer Register (E-PRTR). The facility-specific emission data has been cross-checked and significantly updated using national reports on verified emissions for the Emission Trading System (EU ETS), national inventory submissions to the United Nations Framework Convention on Climate Change (UNFCCC, 2010), as well as other national registers (SFT, 2010) and company specific reports. The data represents only direct CO<sub>2</sub> emissions from the specific facilities listed. No indirect or other greenhouse gas emissions are included in the database. The facilities have been categorized into ten sectors according to the type of industry for statistical analysis of the data. The database includes geographic coordinates for the facilities, and Geographical Information Systems (GIS) has been used for constructing maps from the data (Figure 2.1). The complete database is listed in Appendix A and larger maps can be found in Appendix B.

---

<sup>3</sup> Biogenic CO<sub>2</sub> emissions are emissions generated as a result of biomass combustion.



## 2. CO<sub>2</sub> emissions in the Nordic countries

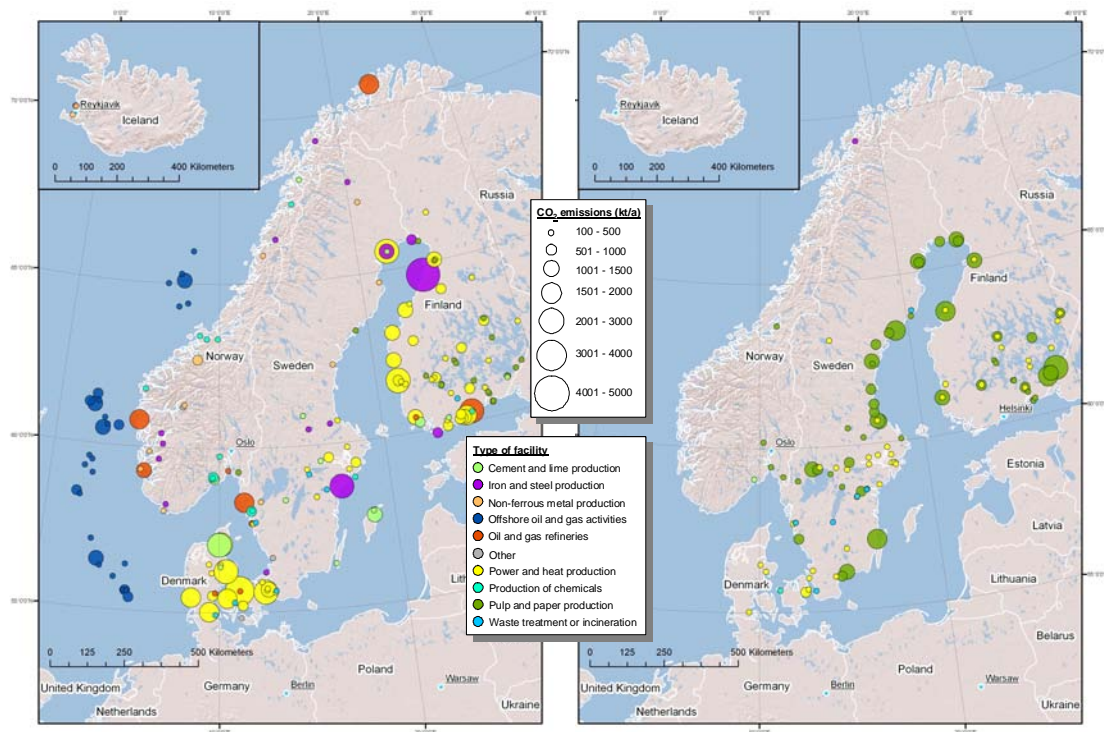

Figure 2.1. Maps over CO<sub>2</sub> emissions from facilities emitting > 0.1 Mt CO<sub>2</sub>/a in the Nordic countries in 2007 (left: fossil and inorganic CO<sub>2</sub> emissions; right: biogenic CO<sub>2</sub> emissions).

### 2.1 Finland

In year 2007, 82 Finnish facilities emitted more than 100 000 t CO<sub>2</sub>. In total, these facilities emitted 39.8 Mt CO<sub>2</sub> of fossil or mineral origin<sup>4</sup>. For comparison, the total amount of Finnish greenhouse gas emissions reported to the UNFCCC that year was 78.3 Mt CO<sub>2</sub>-eq<sup>5</sup>, of which 66.1 Mt was (fossil) CO<sub>2</sub> (UNFCCC, 2010). Of the fossil and mineral CO<sub>2</sub> emissions from the 82 facilities 62% originated from power and heat production, with iron and steel production being the second largest sector (Figure 2.2).

<sup>4</sup> CO<sub>2</sub> emissions of mineral (i.e inorganic) or fossil origin are hereafter referred to simply as “fossil” CO<sub>2</sub>.

<sup>5</sup> All national emission data is presented as gross emissions without land use, land-use change and forestry taken into consideration.

## 2. CO<sub>2</sub> emissions in the Nordic countries

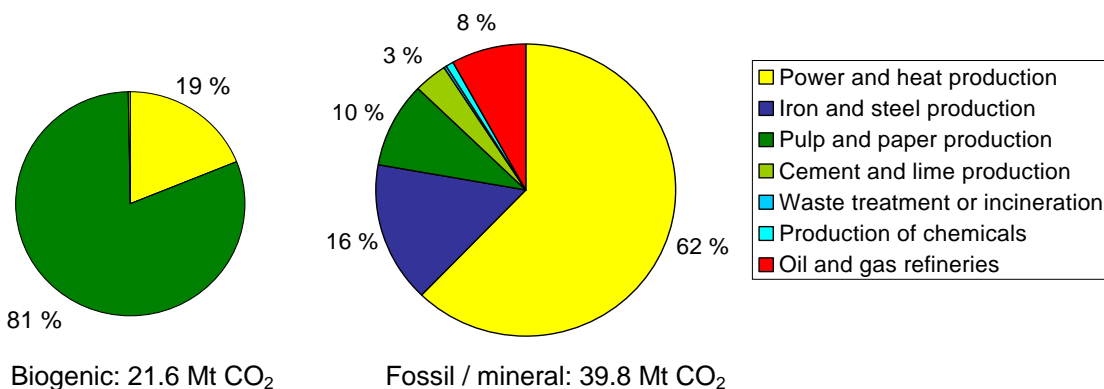

Figure 2.2. CO<sub>2</sub> emissions from facilities emitting > 0.1 Mt CO<sub>2</sub>/a in Finland categorized according to industrial activity (data for year 2007).

The ten largest facilities accounted for 19.1 Mt fossil CO<sub>2</sub> emissions in 2007. The by far largest CO<sub>2</sub> emitting facility in the Nordic countries is the Raahе Steel Works in Finland (4.72 Mt fossil CO<sub>2</sub> in 2007), which produces hot rolled steel plates and strip products from iron ore concentrate. It is also the largest steel works in the Nordic countries. The second largest facility in Finland from a CO<sub>2</sub> emission perspective is the Porvoo refinery (2.75 Mt fossil CO<sub>2</sub> in 2007). The refinery has a capacity of approximately 206 000 bbl/d and produces some 12 million tons of petroleum products a year. The following eight largest CO<sub>2</sub> emitting facilities are condensing power plants (Meri-Pori and Kristiina) and combined heat and power (CHP) plants (Pietarsaari, Helsinki, Oulu, Naantali and Vaasa), of which each accounted for over one million ton fossil CO<sub>2</sub> in 2007.

There is a significant amount of large biogenic CO<sub>2</sub> emission sources in Finland, (21.6 Mt CO<sub>2</sub> in 2007) which is mostly originating from recovery boilers in pulp factories. The biogenic CO<sub>2</sub> emissions from the facilities in the database amount to two thirds of the total CO<sub>2</sub> emissions from biomass combustion in Finland in 2007, which amounted to 32.6 Mt CO<sub>2</sub> (UNFCCC, 2010). When taking both fossil/mineral and biogenic CO<sub>2</sub> emissions into account the pulp and paper production becomes the second largest emitting sector after power and heat production. The nine largest pulp and paper mills<sup>6</sup> (Imatra, Pietarsaari,

<sup>6</sup> The Kaskinen pulp mill was closed down in 2009 and has therefore been removed from the database.

Kaukas, Oulu, Kemi, Veitsiluoto, Joutseno, Rauma and Kymi) each accounted for over one million ton (mostly biogenic) CO<sub>2</sub> in 2007. The biogenic share in power and heat production originates mostly from co-firing with fossil fuels.

### 2.2 Denmark

In Denmark, the number of facilities emitting more than 100 000 t CO<sub>2</sub> was 47 in year 2007. In total, these facilities emitted 29.1 Mt fossil CO<sub>2</sub>. For comparison, the total Danish greenhouse gas emissions (excluding Greenland and the Faroe Islands) were 66.6 Mt CO<sub>2</sub>-eq in 2007, of which 53.2 Mt was (fossil) CO<sub>2</sub> (UNFCCC, 2010).

The most significant share of the facility-specific emissions (69% of fossil CO<sub>2</sub>) comes from power and heat production (Figure 2.3). Nine of the ten largest Danish CO<sub>2</sub> emitters are power and heat plants: Asnæs, Avedøre, Nordjylland, Studstrup, Ensted, Esbjerg, Fyn, Amager and Stigsnæs. These accounted for 18.1 Mt fossil CO<sub>2</sub> in 2007, which was 34% of Denmark's total fossil CO<sub>2</sub> emissions that year. The largest single emitter is the Asnæs power station (3.25 Mt fossil CO<sub>2</sub> in year 2007), which is a CHP plant consisting of three units using coal as its main fuel. Co-firing of biomass in power plants is the largest source of biogenic CO<sub>2</sub>. Avedøre combined power and heat plant is the by far the largest emitter of biogenic CO<sub>2</sub> in Denmark (0.64 Mt biogenic CO<sub>2</sub> and 2.19 Mt fossil CO<sub>2</sub> in year 2007). According to UNFCCC (2010) the total CO<sub>2</sub> emissions from biomass in Denmark that year amounted to 12.1 Mt. Apparently most of that came from facilities emitting annually less than 100 kt CO<sub>2</sub> each, because the total biogenic CO<sub>2</sub> emissions from Danish facilities in the database amounted only to 2.1 Mt CO<sub>2</sub>.

The cement production facility in Aalborg is the second largest emitter of fossil and mineral CO<sub>2</sub> in Denmark, accounting for 2.19 Mt CO<sub>2</sub> in 2007. It is the only manufacturer of cement in Denmark with an annual capacity of 3 million tons of cement. Waste treatment or incineration is the third largest CO<sub>2</sub> emitting sector, with the largest facility (close to Copenhagen) emitting 0.52 Mt fossil CO<sub>2</sub> in 2007. CO<sub>2</sub> emissions from oil and gas activities (mostly offshore platforms) are also significant in Denmark.

## 2. CO<sub>2</sub> emissions in the Nordic countries

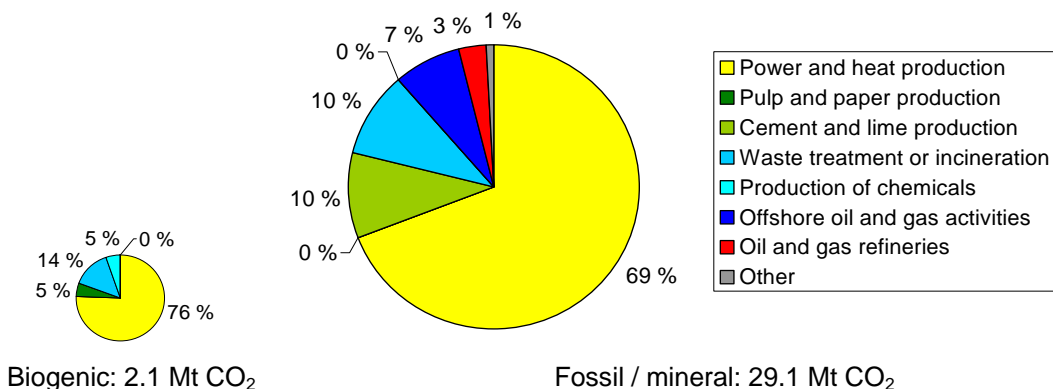

Figure 2.3. CO<sub>2</sub> emissions from facilities emitting > 0.1 Mt CO<sub>2</sub>/a in Denmark categorized according to industrial activity (data for year 2007).

### 2.3 Sweden

In 2007, 88 Swedish facilities emitted more than 100 000 t CO<sub>2</sub>. In total these facilities emitted 19.0 Mt fossil CO<sub>2</sub>. For comparison, the total Swedish greenhouse gas emissions were 65.4 Mt CO<sub>2</sub>-eq in 2007, of which 51.6 Mt was (fossil) CO<sub>2</sub> (UNFCCC, 2010). The emissions originated from many different industrial activities, with iron and steel production and power and heat production being the two largest sectors (Figure 2.4).

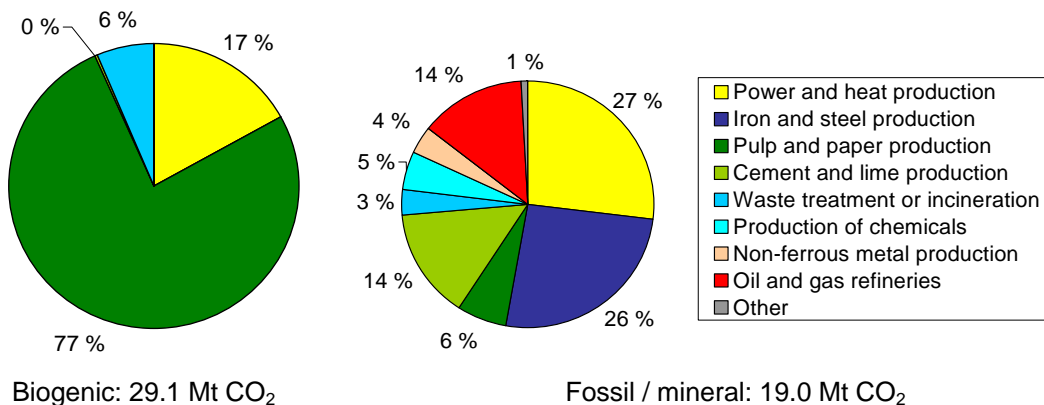

Figure 2.4. CO<sub>2</sub> emissions from facilities emitting > 0.1 Mt CO<sub>2</sub>/a in Sweden categorized according to industrial activity (data for year 2007).

Iron and steel works, power and heat plants, oil and gas refineries and cement factories are among the ten largest fossil CO<sub>2</sub> emitting facilities in Sweden. The largest CO<sub>2</sub> emitting facility was the integrated steel works at Oxelösund (2.42 Mt fossil CO<sub>2</sub>), which is Sweden's only steel works that has a complete production line from raw material to rolled steel plate. The factory produces about 790 000 t steel plate per year. The power and heat plant in Luleå was the second largest emitter, emitting 2.21 Mt CO<sub>2</sub> in 2007.

The Swedish biogenic CO<sub>2</sub> emissions from the 88 largest facilities were even larger than the fossil CO<sub>2</sub> emissions in 2007. The total biogenic CO<sub>2</sub> emissions from the Swedish facilities listed in the database amount to 29.1 Mt, which exceeds the amount reported to UNFCCC for that year (22.7 Mt CO<sub>2</sub> from biomass combustion; UNFCCC, 2010). It is worth noting that the biogenic CO<sub>2</sub> emissions in the database have been double checked for each Swedish facility. Most of the biogenic CO<sub>2</sub> emissions originate from the pulp and paper plants, of which the largest single plants (> 1.0 Mt/a biogenic CO<sub>2</sub>) are located in Husum, Mönsterås, Skutskär, Gruvön, Korsnäs, Östrand, Piteå, and Mörrum.

### 2.4 Norway

In Norway, the number of facilities emitting more than 100 000 t CO<sub>2</sub> was 57 in year 2007. In total these facilities emitted 23.7 Mt fossil CO<sub>2</sub>. For comparison, the total Norwegian greenhouse gas emissions were 55.1 Mt CO<sub>2</sub>-eq in 2007, of which 45.0 Mt was (fossil) CO<sub>2</sub> (UNFCCC, 2010). Among the 57 largest CO<sub>2</sub> emitting facilities in 2007 there are no emissions from power and heat generation, since power generation in Norway relies predominantly on hydropower.

Two thirds of the facility-specific emissions originate from oil and gas activities, with offshore oil and gas activities accounting for one fourth of Norway's total fossil CO<sub>2</sub> emissions. The two largest single CO<sub>2</sub> emitting facilities are the refinery at Mongstad (1.64 Mt fossil CO<sub>2</sub> in 2007) and the Hammerfest LNG Plant at Melkøya (1.62 Mt fossil CO<sub>2</sub> in 2007). The Mongstad refinery is the largest in Norway and has an annual capacity of 10 million tonnes of crude oil. Other significant CO<sub>2</sub> emitting facilities are chemical factories, aluminium producers and cement producers.

The biogenic CO<sub>2</sub> emissions in Norway are practically of no interest for CCS purposes. The biogenic CO<sub>2</sub> emissions from the facilities in the database amounted to 1.3 Mt CO<sub>2</sub>, while the total CO<sub>2</sub> emissions from biomass combustion was according to UNFCCC (2010) 5.2 Mt in 2007. Most of the biogenic

## 2. CO<sub>2</sub> emissions in the Nordic countries

CO<sub>2</sub> emitting facilities are relatively small, with annual emissions of up to 0.3 Mt biogenic CO<sub>2</sub>.

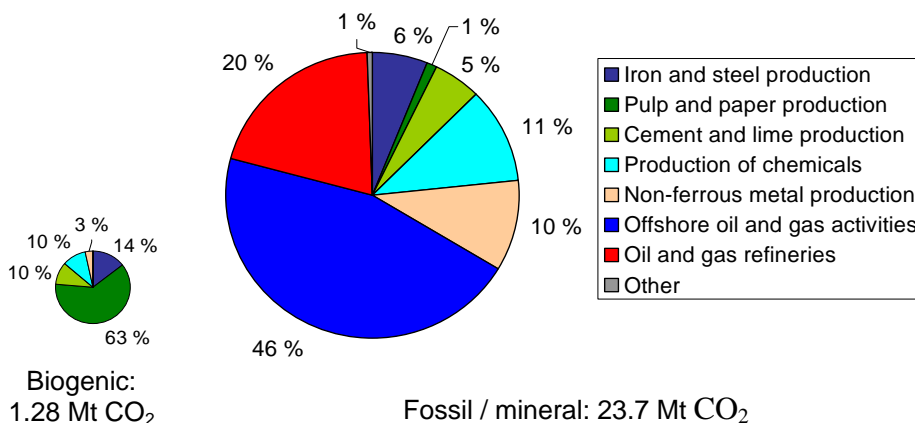

Figure 2.5. CO<sub>2</sub> emissions from facilities emitting > 0.1 Mt CO<sub>2</sub>/a in Norway categorized according to industrial activity (data for year 2007).

## 2.5 Iceland

In Iceland there were only three industrial facilities with CO<sub>2</sub> emissions exceeding 0.1 Mt in 2007: two aluminium plants and one ferroalloy plant. In total, these accounted for 1.08 Mt (fossil) CO<sub>2</sub> in 2007. In comparison, the total Icelandic greenhouse gas emissions were 4.48 Mt CO<sub>2</sub>-eq in 2007, of which 3.29 Mt was CO<sub>2</sub> (UNFCCC, 2010). There were no reported biogenic CO<sub>2</sub> emissions in 2007.

The aluminium and ferroalloy industries are important parts of Iceland's economy. Both use substantial amounts of energy, and rely therefore on inexpensive geothermal and hydroelectric energy. Since Iceland has few proven mineral resources, the raw materials for the plants are imported.

The ferroalloy plant at Grundartangi produces ferrosilicon that is exported (0.43 Mt CO<sub>2</sub> in 2007). Ferrosilicon is one of the elementary materials for steel refining. Ferrosilicon is produced by reduction of silica or sand with coke in the presence of scrap iron or another source of iron. Iceland produced 114 000 t of ferrosilicon in 2007 (USGS, 2010).

The two aluminium plants in Grundartangi (0.36 Mt CO<sub>2</sub> in 2007) and Hafnarfjörður (0.29 Mt CO<sub>2</sub> in 2007) produced 400 000 t aluminium in 2007 (USGS,

2010). In primary aluminium production, direct CO<sub>2</sub> emissions occur due to the reaction between oxygen and carbon anodes in the electrolysis process. A new smelter at Reydarfjordur started production in 2008 and another one is planned to be constructed near Husavik in 2012.

The geothermal energy installations in Iceland emit CO<sub>2</sub> as well. However, the total CO<sub>2</sub> emissions from geothermal energy amounted only to 0.15 Mt CO<sub>2</sub> in 2007 (UNFCCC, 2010). In 2008 these emissions had risen to 0.19 Mt CO<sub>2</sub>. The largest single geothermal power station at Iceland is the Hellisheidi Power Station, which emits at full capacity 24 300 t CO<sub>2</sub> yearly (Orkuveita Reykjavíkur, 2010). Since this is well below the lower emission limit of 0.1 Mt/a for this database none of the geothermal energy plants are listed in this report.

## 2.6 Summary and comparison of the Nordic countries

In total, there were 277 facilities in the Nordic countries in year 2007 that emitted more than 100 000 t CO<sub>2</sub> that year. The total sum of the fossil emissions from these facilities was 113 Mt CO<sub>2</sub>, which corresponds to 51% of the total (fossil) CO<sub>2</sub> emissions from the Nordic countries that year<sup>7</sup>. Power and heat plants accounted for the largest part (45%) of these emissions (Figure 2.6). Most of these plants were located in Finland and Denmark (Figure 2.7). Oil and gas activities accounted for the second largest share of the emissions (22%), with refinery emissions in all countries (except Iceland) and most of the offshore activities in Norway. Iron and steel production was the third largest sector, of which most plants were located in Finland and Sweden. Emissions from large cement plants were found in all countries except Iceland.

The total sum of the biogenic emissions from the facilities in the database was 54 Mt CO<sub>2</sub>, which is a considerable amount. Most of these emissions (76%) came from large pulp and paper factories in Finland and Sweden (Figure 2.8). The second largest share (20%) came mostly from combustion and/or co-firing of biomass in power and heat plants in Finland, Sweden and Denmark.

There were only 31 facilities in the Nordic countries with fossil CO<sub>2</sub> emissions exceeding 1.0 Mt CO<sub>2</sub> in 2007 (Figure 2.9). The total amount of fossil CO<sub>2</sub> emissions from these facilities amounted to 57 Mt, which corresponds to 26% of the

---

<sup>7</sup> The comparison was made to the sum of the national CO<sub>2</sub> emissions as reported to the UNFCCC in 2007. The remaining 49% is most likely to be attributed to small stationary sources and emissions from the transport sector, although a balance calculation for verifying that was not performed.

## 2. CO<sub>2</sub> emissions in the Nordic countries

total (fossil) CO<sub>2</sub> emissions from the Nordic countries that year. When taking into account both biogenic and fossil CO<sub>2</sub> emissions the number of facilities exceeding 1.0 Mt CO<sub>2</sub> increases to 50. The total amount of biogenic and fossil CO<sub>2</sub> emissions from these facilities amounted to 88 Mt.

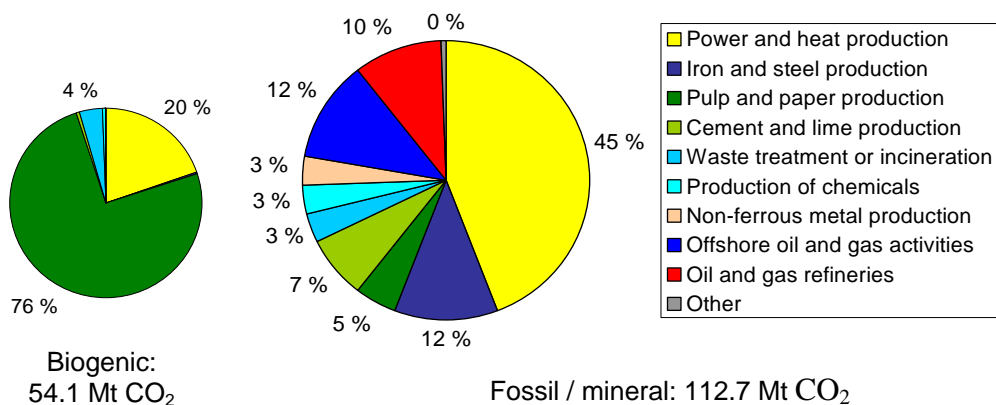

Figure 2.6. CO<sub>2</sub> emissions from facilities emitting > 0.1 Mt CO<sub>2</sub>/a in the Nordic countries categorized according to industrial activity (data for year 2007).

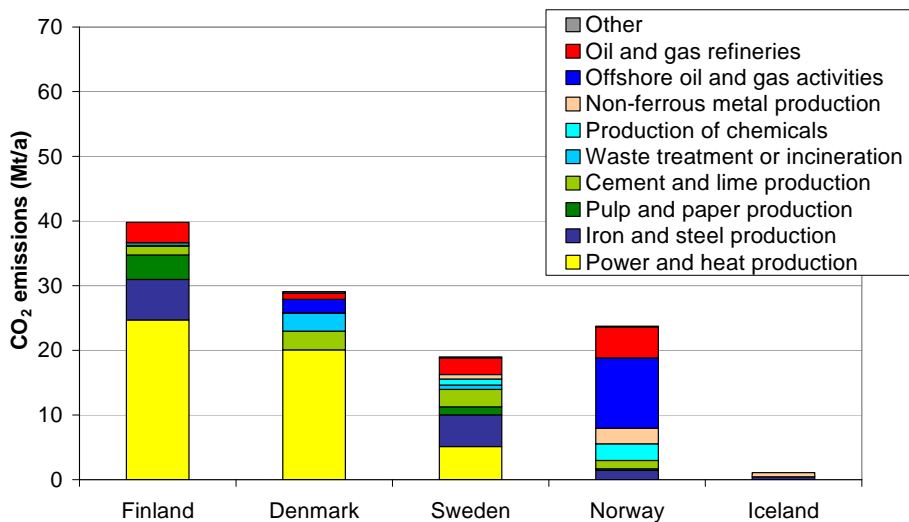

Figure 2.7. Fossil CO<sub>2</sub> emissions from facilities emitting > 0.1 Mt CO<sub>2</sub>/a in the Nordic countries in 2007.



## 2. CO<sub>2</sub> emissions in the Nordic countries

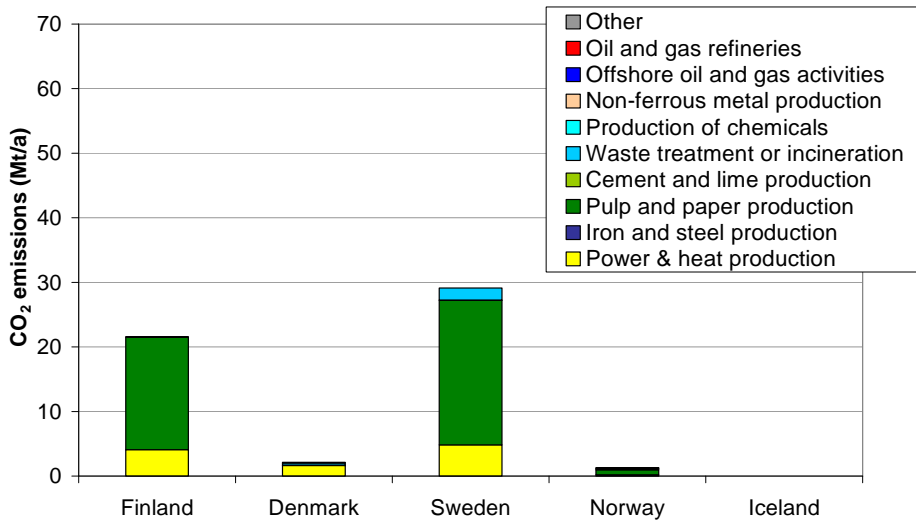

Figure 2.8. Biogenic CO<sub>2</sub> emissions from facilities emitting > 0.1 Mt CO<sub>2</sub>/a in the Nordic countries in 2007.

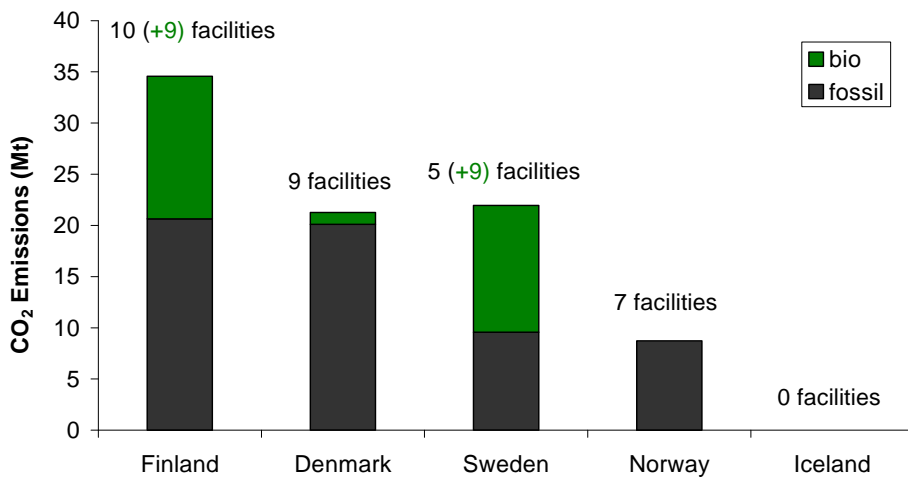

Figure 2.9. Amount of CO<sub>2</sub> emissions from facilities emitting over 1.0 Mt CO<sub>2</sub>/a in the Nordic countries in 2007.

### **3. CCS technologies suitable for Nordic conditions**

The feasibility of applying CCS to an industrial process or power plant is largely dependent of the energy requirements of the capture process. Applying CCS technology to power plants would reduce the CO<sub>2</sub> emissions from combustion with 80–90%, but it would also almost double the production cost for power and requires more fuel to supply energy for the capture process using current technologies. Therefore, it is not surprising that CCS has not yet been applied to full extent at a large-scale fossil-fuel power plant. A large challenge for the development of CO<sub>2</sub> capture technology is to reduce the energy requirements of the capture processes, because the largest part of the costs of CCS projects comes from CO<sub>2</sub> capture.

Based on the current large-scale CO<sub>2</sub> point sources, the power and heat sector seems to have the largest potential for CCS application in the Nordic countries, with most of the point sources being situated in Finland and Denmark. However, iron and steel production, oil and gas activities and cement industry account in total for an equally large amount of emissions. If biogenic CO<sub>2</sub> emission sources are included, the pulp and paper industry would stand for the second largest share of emissions, next to the power and heat sector. Most of the research and development of CCS technologies has so far been concentrated on solutions for power plants, and there is very little information on application of CCS in other processes.

#### **3.1 CO<sub>2</sub> capture**

CO<sub>2</sub> contained in a flue gas can be trapped in various ways, most commonly via absorption or adsorption using a solvent or an agent with a strong bonding to the CO<sub>2</sub> (chemically or physically). In order to re-use the agent in a cyclic manner

the CO<sub>2</sub> must be stripped off whereby the agent regains its bonding capability. The stripping requires energy, either as a heat input (temperature swing) or electric power (pressure swing). Other ways of separating CO<sub>2</sub> go via energy demanding cryogenic processes, especially in combination with oxy-fuel combustion (see Chapter 3.1.3). A major challenge is associated with the separation work, as the real work is far more extensive than the theoretical work (Figure 3.1). Basically, the lower the CO<sub>2</sub> concentration of a gas stream is, the more work is required to separate it. Therefore, energy penalty is a major issue that relates to any CCS technique. This also applies to compression, as the theoretical power input is only around half of the power that is needed in practical applications.

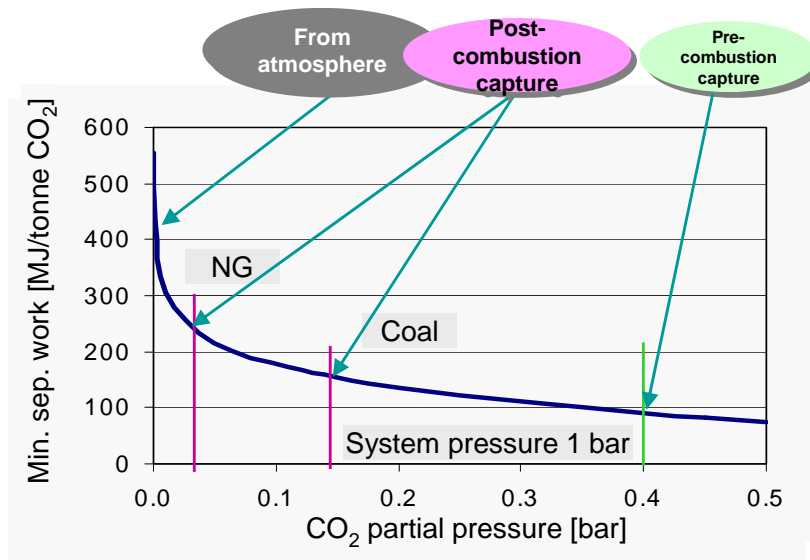

Figure 3.1. Minimum separation work versus partial pressure of CO<sub>2</sub> with post-combustion and pre-combustion capture with coal (and post-combustion with natural gas).

Three main technological methods are under development in order to realise CCS for power plants – broadly characterised according to where or how the CO<sub>2</sub> is removed – notably *post-combustion capture*, *pre-combustion capture*, and *oxy-fuel combustion capture*. In Table 3.1 the main characteristics and integration of prevalent CCS technologies are summarised for reference.

### 3. CCS technologies suitable for Nordic conditions

Table 3.1. Brief characteristics of prevalent CO<sub>2</sub> capture processes.

	Post-combustion	Pre-combustion	Oxy-fuel combustion
Technology description	Separation of CO <sub>2</sub> from flue gas or other process gas – either via chemical or physical absorption (depending on CO <sub>2</sub> concentration).	Separation of CO <sub>2</sub> at high pressure from a shifted syngas (rich in CO <sub>2</sub> and H <sub>2</sub> ), after which the resulting hydrogen-rich gas is combusted in a gas turbine-based cycle. Gasification of the fuel requires oxygen from a cryogenic air separation unit (ASU).	Oxygen (instead of air) is used as an oxidant and the combustion leaves a flue gas consisting mainly of water and CO <sub>2</sub> . The oxygen required by the process is separated from air using an ASU. In order to reduce the combustion-zone temperature flue gas re-circulation is (usually) required.
CO <sub>2</sub> treatment	Chemical absorption (usually amine-based solutions), or physical adsorption (at higher CO <sub>2</sub> concentration)	Physical adsorption.	Cryogenic purification of CO <sub>2</sub> prior to compression (if appropriate) – mainly depending on purity specification with regards to transport system or storage site.
Key technology status / availability	Absorption technology known from gas processing and chemical industries, although in considerably smaller units than what is needed in the power sector.	Several operational IGCC plants around the world. But, no integrated CCS system so far. Semi-scaled demonstration not feasible owing to suitability and size of heavy-duty gas turbines. No guarantee for IGCC-CCS available from suppliers.	Small-scale plants around 30 MW are operational (since 2008) in support of R&D. Mostly for pulverised coal and lignite. Growing interest for CFB (circulating fluidised bed) technology. Also pressurised combustion is gaining interest.
Challenges	<ul style="list-style-type: none"> <li>• Scale and integration of complete systems for flue gas cleaning</li> <li>• Composition of flue-gas (concentration of CO<sub>2</sub> as well as SO<sub>2</sub> and other impurities)</li> <li>• Slippage of solvent may become a health, safety and environmental issue</li> <li>• Energy penalty (i.e. high energy demand for regenerating the solvent)</li> <li>• Water balance (need for process water)</li> </ul>	<ul style="list-style-type: none"> <li>• High capital expenses</li> <li>• Only full-sized demonstration (owing to availability of gas turbines)</li> <li>• Degree of integration of large IGCC plants versus flexibility</li> <li>• Operational availability with coal in base load</li> <li>• Capital and operating costs</li> <li>• Lack of readiness (so far) to raise the commercial guarantees needed for large IGCC-CCS plants</li> <li>• Hydrogen-burning gas turbine with low NO<sub>x</sub> emission</li> </ul>	<ul style="list-style-type: none"> <li>• High capital expenses</li> <li>• High operating costs</li> <li>• Size, cost and exergy demand for cryogenic air separation (ASU)</li> <li>• Peak temperatures versus flue gas re-circulation</li> <li>• NO<sub>x</sub> formation</li> <li>• Optimisation of overall compressor work (ASU, CPU and CO<sub>2</sub> compression)</li> <li>• Lack of commercial guarantees</li> </ul>

<b>Main features</b>	Low CO <sub>2</sub> concentration (i.e. typically 12–15% with coal and around 3% with natural gas). Conventional power cycle. Large extraction rate of steam at around 4 bar.	Typical CO <sub>2</sub> concentration around 40% (pressure around 30 bar). Offers a high development potential owing to the combined power cycle. Lower demand for oxygen than that of oxy-fuel combustion schemes, as only a small amount is needed for auto-thermal oxidation in the gasifier.	High concentration of CO <sub>2</sub> and water vapour in the flue gas. Possibility for knocking out process water. Typical CO <sub>2</sub> concentration > 90% with coal and > 85% with natural gas (both cases with 3% excess oxygen).
----------------------	---	--	--

### 3.1.1 Post-combustion capture

Post-combustion capture (Figure 3.2) is applied to conventional power-plant or process technology in which the CO<sub>2</sub> (up to around 90% of it) is removed from the flue gas or another process gas. This requires mainly heat for the regeneration of the solvent and electric power for compression, pumps and fans. These techniques may be suitable for new plants and for retrofitting of existing plants with CCS.

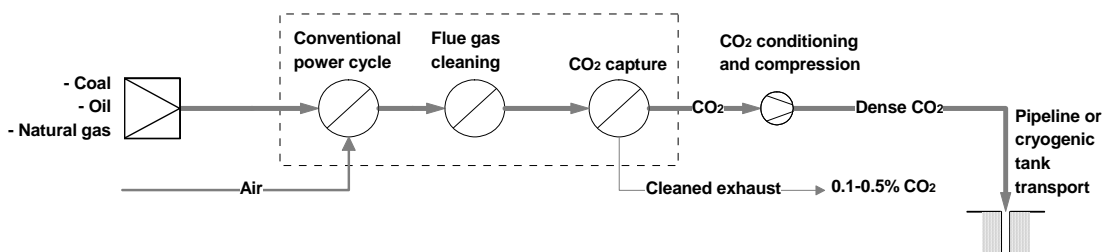

Fuel	Combustion	Oxygen supply	Separation
Coal	Fuel with air (conventional)	no	Absorption (chemical)
Natural gas			Adsorption
			Membranes

Figure 3.2. Typical post-combustion scheme for power plants.

### 3. CCS technologies suitable for Nordic conditions

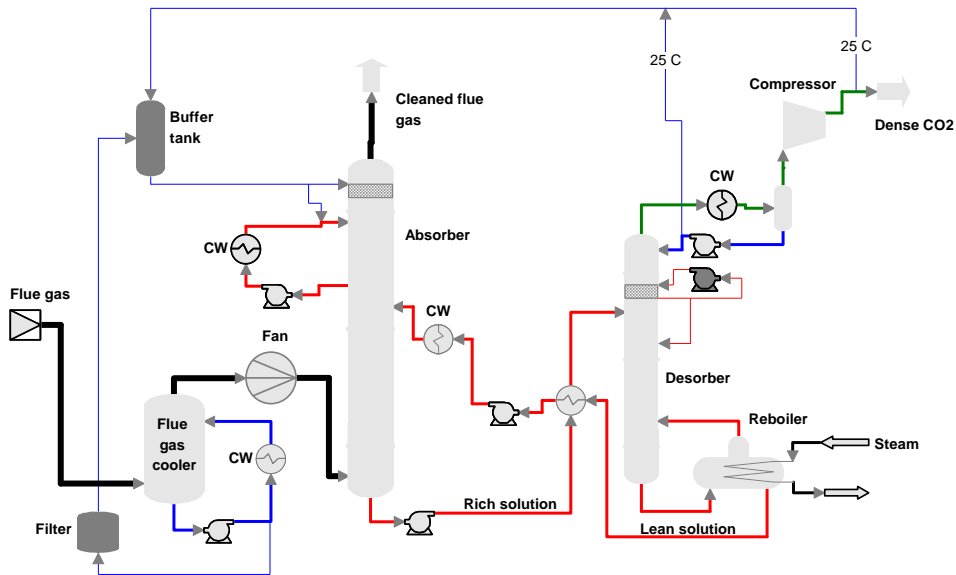
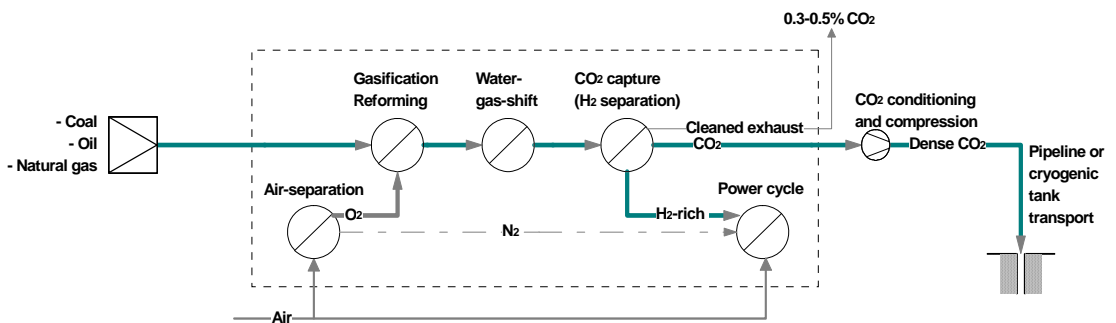

Figure 3.3. Typical absorption process for post-combustion capture systems using amine-based solvents (Hetland et al., 2009, Kvamsdal et al., 2010).

Post-combustion capture is based on a system using either absorption or adsorption technology (Figure 3.3). Although numerous chemical and physical solvents are considered suitable agents, a generic aqueous solution of monoethanolamine (20–30% MEA) is used in many studies and pilots, however, with some proprietary additives that prevent corrosion and foaming. In systems based on absorption technology the solvent absorbs CO<sub>2</sub> at typically 40–60°C (Hetland et al., 2009). The solvent leaving at the bottom of the desorber is then heated to typically 120°C in a reboiler where the CO<sub>2</sub> is stripped off, and a hot CO<sub>2</sub>/steam mixture is introduced to the lower section of the desorber unit. The CO<sub>2</sub> stream will then ascend through the column (counter-current of the trickling rich solvent) and leave the column at the top. It then diverts to compression and dehydration throughout multiple stages before a sufficiently pure and dense CO<sub>2</sub> stream is ready for transport to the storage site. Due to the energy required by the capture process, the electric efficiency of the power plant is reduced by approximately 9–15% units.

### 3.1.2 Pre-combustion capture

Carbon dioxide can be captured prior to combustion as well (Figure 3.4). By gasification, solid or liquid fuel is converted into combustion gas mainly composed of hydrogen, carbon monoxide and carbon dioxide. After cleaning, this gas can be utilised in gas turbine applications (IGCC, Integrated Gasification Combined Cycle) or in gas processing. With water gas shift the carbon monoxide in the combustion gas can be shifted so that the gas mainly contains hydrogen and carbon dioxide. Because of the relatively high partial pressure of carbon dioxide physical or physiochemical absorption can be used to capture the CO<sub>2</sub>. In comparison to chemical solvents used in post combustion capture processes physical solvents generally have a lower energy demand per unit captured CO<sub>2</sub>. After separation of CO<sub>2</sub> hydrogen rich gas can fuel a gas turbine or fuel cell, or be used as a raw material in the chemical industry.



Fuel	Combustion	Oxygen supply	Separation
Coal, refinery residues, ... via gasification <i>IGCC (Integrated Gasification CC)</i>	H <sub>2</sub> enriched fuel gas with air	Cryogenic ASU	Absorption (physical or chemical)
Natural gas via reforming <i>IRCC (Integrated Reformer CC)</i>		O <sub>2</sub> via membranes	H <sub>2</sub> via membranes
			CO <sub>2</sub> via membranes

Figure 3.4. Pre-combustion capture scheme.

Physical solvents are commercially available by names such as Selexol, Rectisol and Purisol. Although the capture technology is available, turbines capable of

### 3. CCS technologies suitable for Nordic conditions

firing pure hydrogen or fuel cells remain to be developed and scaled up to industrial scale typical of the power sector. It should be noted, however, that chemical absorption requires special care when used in IGCC-CCS schemes, as some slippage of the solvent may have a detrimental impact on the gas turbine, which needs to be further scrutinised.

Although the gasification and gas turbine processes are more complex and expensive than in conventional coal-fired power plants the separation is easier because of the higher partial pressure of CO<sub>2</sub> that allows the use of physical solvent processes. Due to the energy required by the capture process, the electric efficiency of the power plant would be approximately 5–8% units lower than an IGCC plant without CCS. At the moment similar CO<sub>2</sub> capture methods are used in industrial processes e.g. in hydrogen production. Very few power plants based on gasification exist today, so the main application would be for new power plants.

Unlike post-combustion and oxy-fuel combustion techniques, pre-combustion offers the options of co-producing coal-derived synthetic fuels (Figure 3.5). Hence, with polygeneration various chemical products are combined with electric power generation. Polygeneration may respond significantly to the issue of security of energy supply, and may become efficient in meeting the requirements for CO<sub>2</sub> reduction, because the isolation of CO<sub>2</sub> from the gas stream constitutes an inherent feature of the concept, whereby the additional cost and fuel penalty of removing the CO<sub>2</sub> largely relate to the compression. Furthermore, polygeneration may improve the flexibility of IGCC-CCS plants, as the gasifier may operate constantly at nominal load whereas the response to the varying demand is handled by the power cycle using the chemical yields as swing products.



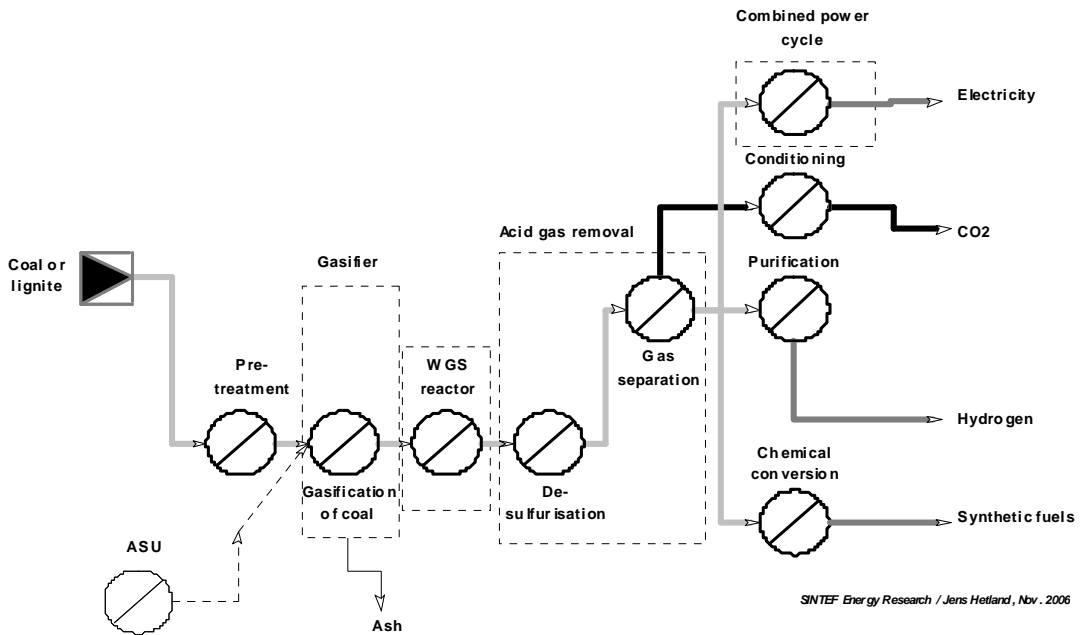

Figure 3.5. Polygeneration from coal broken down in unit operations (Hetland et al., 2008a).

### 3.1.3 Oxy-fuel combustion

In oxy-fuel combustion systems the fuel is combusted in oxygen and re-circulated flue gas (Figure 3.6). Because there is a limited amount of nitrogen present in the oxidant, the flue gases compose of mainly CO<sub>2</sub> (80–95 vol% dry), which makes separation of CO<sub>2</sub> easier and less energy demanding. Other components in the resulting flue gas are H<sub>2</sub>O, excess oxygen and pollutants from fuel, such as SO<sub>2</sub>, NO, N<sub>2</sub>O and HCl. These pollutants are removed in a CO<sub>2</sub> processing unit, based mainly on compression and cooling.

### 3. CCS technologies suitable for Nordic conditions

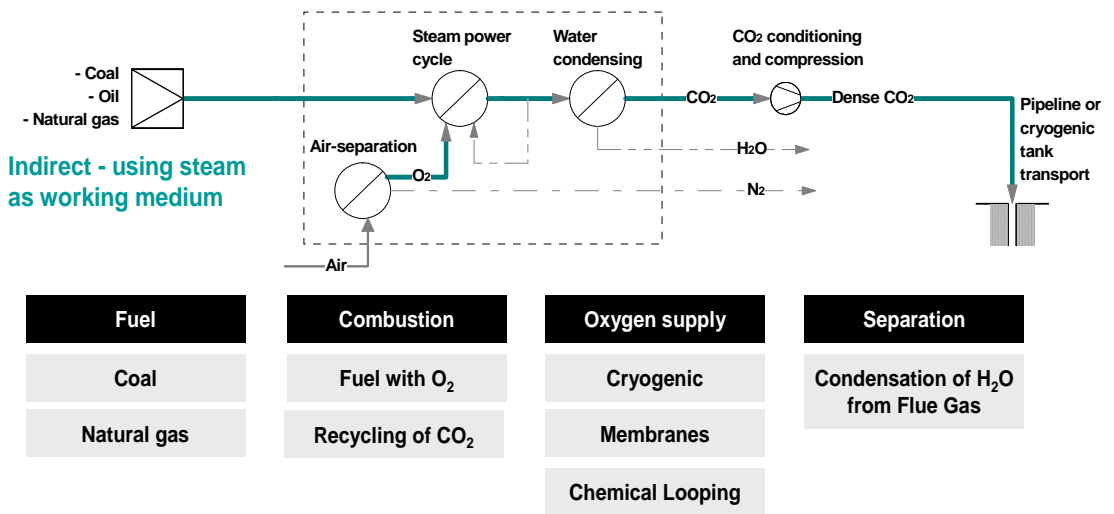

Figure 3.6. Typical oxy-fuel combustion scheme.

In comparison to a conventional power plant, some new components are needed in an oxy-fuel combustion power plant: most notably an air separation unit in the forefront and a CO<sub>2</sub> processing unit at the tail end. These units increase the auxiliary electricity consumption and are therefore lowering the electric efficiency of the power plant by approximately 5–13% units. To decrease the electric power demand of an air separation unit, alternative processes are being developed such as air separation via oxygen transfer membranes. Oxy-fuel combustion technology is currently in the demonstration phase in the scale of tens of megawatts (e.g. Schwarze Pumpe 30 MWth) and (in principle) oxy-fuel combustion schemes are applicable for both greenfield and retrofit installations, although the gas flow is reduced to only around one third of that of conventional boiler systems.

#### 3.1.4 Pre-conditioning and CO<sub>2</sub> compression

Compression of the captured CO<sub>2</sub> represents an integral part of any CCS concept. Usually and preferably, the CO<sub>2</sub> should be dehydrated and transformed into dense phase at super-critical pressure for pipeline transport – or it should be liquefied at pressurised conditions and low temperature for tank shipment (typically around 5–10 bar and close to -50°C). Various restrictions may be imposed

on the purity of the CO<sub>2</sub> depending on transport system, and specific requirements of the sink – mainly for reasons that owe to the overall economics, health and safety issues, material selection versus corrosion, energy demand for compression and precautions to avoid hydrate formation (Hetland et al. 2008b, De Visser et al. 2008).

#### **3.1.5 Future capture technologies**

Emerging technologies range from improvements of existing processes to completely new approaches. Most innovations aim at enhancing the efficiency and lowering the cost relative to established technologies that are considered for industrial applications. These new technologies are in the development phase and thus far from commercialisation.

The focus of post-combustion capture development has been on methods for separating CO<sub>2</sub> from the flue gas stream with a lowest practical energy requirement. However, opting for low energy demand could introduce problems with volatility, and biodegradability, as volatile solvents may escape from the process into the surroundings. Emerging post-combustion capture technologies are based on solid sorbents, membranes, or the use of other liquid solvents, such as ammonia and aqueous carbonates. Other promising technologies in development are based on metal organic frameworks, ionic liquids, enzymatic membranes, and biological processes.

In pre-combustion capture the most pressing development need is within combustion technologies that may enable gas turbines to be fuelled by a hydrogen-rich gas without producing a large amount of NO<sub>x</sub>. Research is also conducted on coal gasification, on sour-shift reactor development and on polymer-based membranes and sorbents as alternative processes for separating the CO<sub>2</sub> from the shifted syngas.

The continuous development of improved and larger-sized air separation units aims at reducing the relative cost for oxygen production. It is possible that new air separation technologies, such as oxygen transport membranes or ceramic autothermal recovery (CAR processes) would significantly improve power generation efficiency and reduce cost. Also, material development for oxy-fuel combustion boilers is an important field.

Chemical looping combustion is a new method that can be used to trap carbon dioxide via oxygen-based combustion without the need for external oxygen sup-

### 3. CCS technologies suitable for Nordic conditions

ply. The idea is to make use of a solid metal-oxide to provide oxygen to oxidise the fuel in one reactor (thereby reducing the metal), and then to re-oxidise the metal by air in a separate reactor. Typically the reaction in the oxidising reactor is exothermic and the reaction in the reduction reactor endothermic. The net heat released in the reactors is the same as in normal combustion. If the reactors are separated with a gas lock, it is possible to get a gas stream containing practically pure CO<sub>2</sub> and H<sub>2</sub>O. This concept can be applied to steam turbine processes and if pressurised also in gas turbine applications. Production of product gas is also possible with partial oxidation. The role of oxygen carrier materials is heavily emphasized in the development of this technology. It is worth noting that Norway, Sweden, Denmark and Finland all have ongoing R&D work related to chemical looping.

## 3.2 CO<sub>2</sub> transportation

Carbon dioxide captured from a power plant or industrial source must be transported to a storage site, since suitable storage sites will be rarely located near the CO<sub>2</sub> source. For an industrial scale application only pipeline or ship transportation are viable options. Other modes of transportation, i.e. transportation by road or railway, lack the needed capacity and cannot be realistically seen as cost effective options for CCS infrastructure.

Distances from CO<sub>2</sub> point sources to potential geological storage sites can be up to 1 000–1 500 km within the region of the Nordic Countries. As the bulk of the CO<sub>2</sub> emitting industry and power generation are spread along the coastlines of the North Sea and the Baltic Sea, the CO<sub>2</sub> has to be transported to the offshore storage sites by water carriers or sub-sea pipelines. Depending on the logistic setting, various transportation modes may have to be used subsequently.

Transportation of CO<sub>2</sub> by pipeline is relatively simple and can be considered a mature technology that has been in use by the oil industry in the United States for enhanced oil recovery since the 1970's. To avoid pipe corrosion the gas cannot contain free water and it must therefore be dehydrated before transportation. Gaseous CO<sub>2</sub> is typically compressed for transportation to a pressure above 80 bar in order to avoid two-phase flow regimes and increase the density of the CO<sub>2</sub>, thereby making it easier and less costly to transport by pipeline. The pipeline has to be carefully designed for reliable operation and best achievable cost-effectiveness. The CO<sub>2</sub> flows need to be well known beforehand, especially in case of a trunkline with multiple connected CO<sub>2</sub>-sources, in order to determine

the optimal pipeline size. Pipelines with larger diameters or thicker walls imply higher capital costs. Too small pipe diameters in turn increase the flow velocity and consequently induce pressure loss, which has to be accounted for by shorter distances between booster pump stations along the pipeline. Additional booster stations increase the capital costs, as well as the operational costs, the latter mainly due to higher energy demand.

Alternatives to pipeline transportation are CO<sub>2</sub> in liquefied state transported in tankers by ships, road or rail. Ship transportation is the fastest and most flexible means to realize the logistics needed for CCS. CO<sub>2</sub> transported by tankers requires intermediate storage with loading and unloading facilities. Liquefaction of CO<sub>2</sub> to conditions near the triple point, where CO<sub>2</sub> has its highest density, sets strict purity requirements, as even low amounts of volatile gases such as argon or nitrogen may cause dry ice to form (Aspelund and Jordal, 2007). So far the largest carriers for CO<sub>2</sub> shipment is in the range of 10 000 t/ship. Current engineering is focusing on ships with a capacity of 10 000–50 000 t CO<sub>2</sub> (IEA, 2008).

### 3.3 CO<sub>2</sub> storage

At the end of the CCS chain the CO<sub>2</sub> is to be stored safely for a long period of time (i.e. several thousand years) in isolation from the atmosphere. Only a few options can be considered because of the large amount of CO<sub>2</sub> that needs to be stored. Currently, the only technology that has reached demonstration level for accomplishing storage on a sufficiently large scale is the use of underground geological formations for the storage of CO<sub>2</sub>. Deep saline aquifers are underground layers of porous rock, filled with salt water, and are considered to be suitable for storage of CO<sub>2</sub>. The storage of CO<sub>2</sub> in the deep ocean is not feasible because of the ecologic uncertainties thereof. Also, recent laws prevent storage of CO<sub>2</sub> in the ocean.

Binding the CO<sub>2</sub> with silicate minerals into solid carbonates is technically possible, but because of the large energy requirements of the current state-of-the-art processes it is not considered as a viable option. There are several industrial processes and applications that use CO<sub>2</sub>. However, the quantities needed are very small compared with the CO<sub>2</sub> emissions. Also, the CO<sub>2</sub> generally ends up in the atmosphere within a relatively short time period after use, and thus it will have no mitigating impact on greenhouse gas emissions.

### 3.3.1 Storage of CO<sub>2</sub> in underground geological formations

Sedimentary basins (natural large-scale depressions in the Earth's crust that are filled with sediments) potentially suitable for CO<sub>2</sub> storage are distributed around the globe, both onshore and offshore. The most promising formations are nearly depleted or depleted oil and gas reservoirs, deep saline formations, and unminable coal beds. In each case, CO<sub>2</sub> could be injected in compressed form into a rock formation at depths greater than 800 m, where the CO<sub>2</sub> is in a liquid or supercritical state because of the ambient pressures. The reservoir needs to have certain characteristics that will ensure that the CO<sub>2</sub> remains trapped underground, such as a well-sealed cap rock on top of the reservoir.

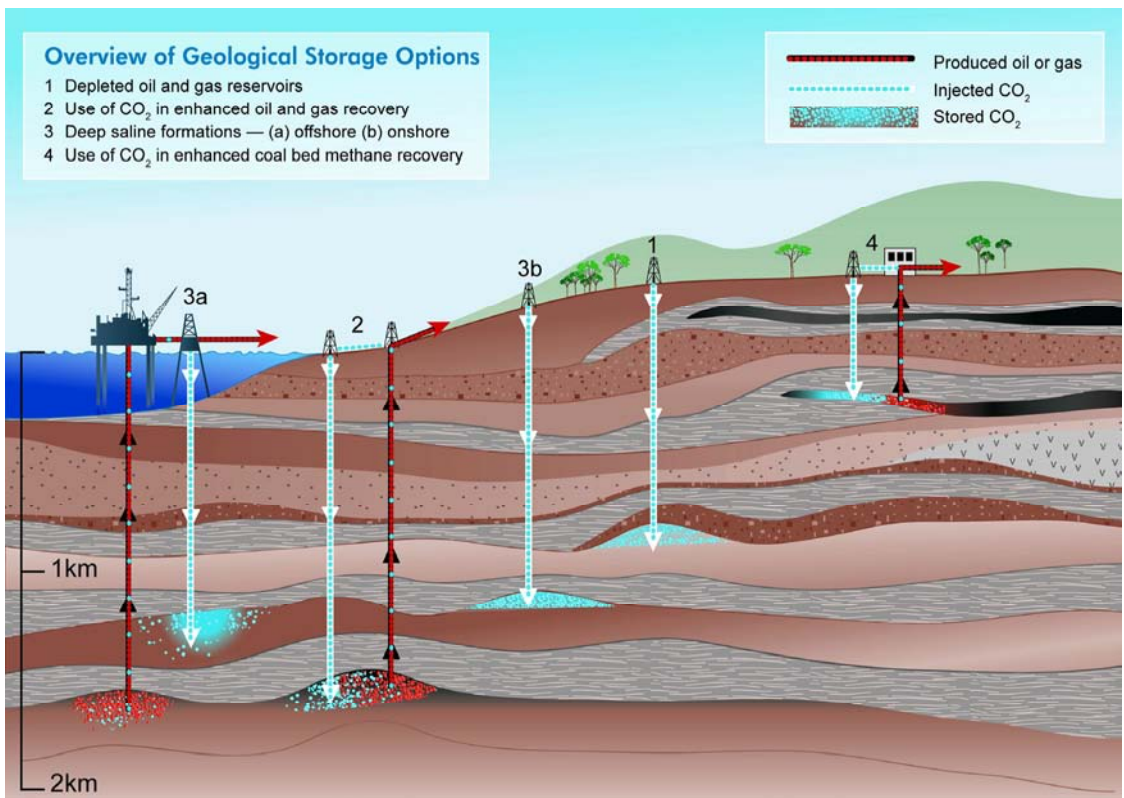

Figure 3.7. Underground storage alternatives (IPCC 2005).

The geochemical trapping of CO<sub>2</sub> (i.e. fixation as carbonates) will eventually occur as CO<sub>2</sub> reacts with the fluids and host rock in the reservoir, but this hap-

pens on a time scale of hundreds to millions of years (Figure 3.8). In order to minimise the risk of CO<sub>2</sub> leakage, the storage sites must be monitored for a very long time. At the moment, four industrial-scale projects around the world are storing a total of 3–4 Mt of CO<sub>2</sub> annually in saline aquifers.

The injection of CO<sub>2</sub> into geological formations involves many of the same technologies that have been developed in the oil and gas exploration and production industry. Carbon dioxide has been used in enhanced oil recovery (EOR) for enhancing the oil recovery from nearly exhausted oil wells since the early 1970s, mostly in Texas, USA. Injection of a CO<sub>2</sub>-water mixture into the well raises the pressure of the well and improves the miscibility of the oil, thus, increasing the oil output of the well by 5–23%. Similar principles can also be applied to enhance the recovery of natural gas. Also, injecting CO<sub>2</sub> into unminable coal beds could allow for recovery of methane bound in the coal bed, but the feasibility of this technology has not yet been demonstrated.

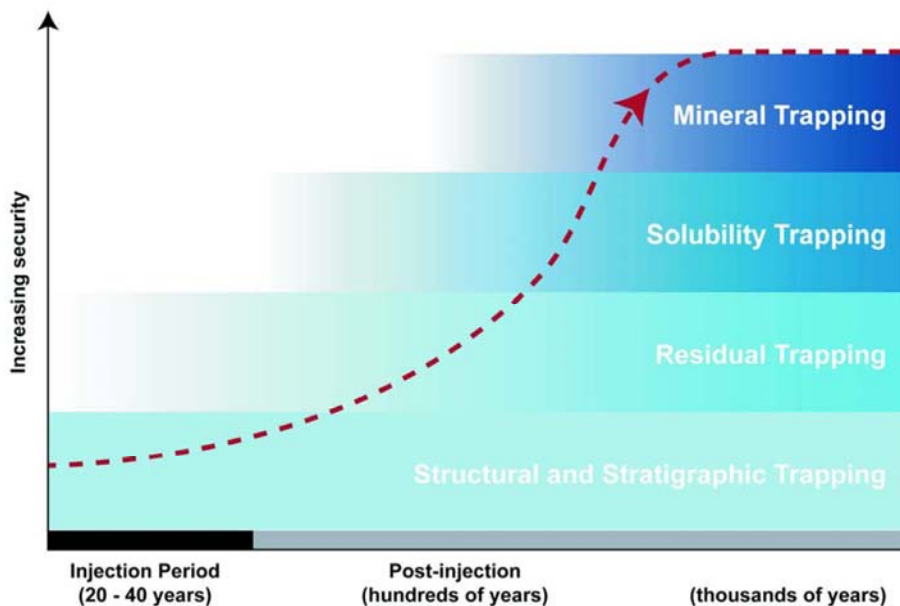

Figure 3.8. Security versus time showing the natural trapping mechanisms when storing CO<sub>2</sub> in saline aquifers (IPCC 2005).

Selection of a site for geological storage requires careful site characterisation and performance prediction. Determination of the integrity of the formation is

### 3. CCS technologies suitable for Nordic conditions

crucial to prevent possible leakage of CO<sub>2</sub>. Continuous monitoring of the storage site is required to detect the movement of CO<sub>2</sub> in the formation for predicting and preventing possible leakages. These issues, including non-discriminatory access to available networks and storage prospects, are required by a recent CCS directive draft by the EU for assuring the permanency of the storage. Also, a recent amendment to the London Protocol legalises storage of CO<sub>2</sub> in sub-sea geological storage structures. Storage is the most likely part of CCS in which public acceptance may become an issue.

While the potential CO<sub>2</sub> storage capacity of oil and gas reservoirs can be estimated based on the replacement of hydrocarbons, the potential of saline aquifers is more difficult to estimate. Europe's effective storage capacity has recently been estimated to 96 Gt CO<sub>2</sub> in deep saline aquifers, 20 Gt in depleted hydrocarbon fields and 1 Gt in unmineable coal beds (GeoCapacity, 2009). Of this, 25% is located offshore Norway, mainly in deep saline aquifers. It has been estimated that 30 Gt of saline aquifer capacity in Europe could be used at a cost of 8-15 €/t<sup>8</sup> and 5 Gt of depleted oil and gas field capacity at a cost of 8–19 €/t (IEA, 2008). The storage capacity in the Nordic region is reported in detail in Chapter 4.2.

#### 3.3.2 CO<sub>2</sub> storage by mineralization

The concept for storage of CO<sub>2</sub> as calcium and magnesium carbonate minerals is commonly referred to as mineral carbonation. These carbonates are poorly soluble in water and environmentally harmless minerals that could provide a permanent storage solution for CO<sub>2</sub>. The metal oxides in silicate rocks that can be found in the Earth's crust could in theory bind all the CO<sub>2</sub> that could be produced by the combustion of all available fossil fuel reserves. Alkaline industrial wastes and by-products, such as steelmaking slags and process ashes, also have high contents of magnesium and calcium, but their CO<sub>2</sub> storage capacity is much more limited. The net reaction equation for carbonation by using calcium- or magnesium-containing silicate minerals can be generalized as

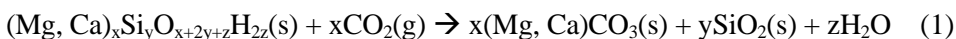

---

<sup>8</sup> Calculated from US\$ using the rate 1 € = 1.3 US\$



There are two main concepts for how CO<sub>2</sub> storage by mineral carbonation could be carried out. In *in situ* carbonation, CO<sub>2</sub> would, similarly to geological storage of CO<sub>2</sub>, be injected into porous rock formations, where the main long-term storage mechanism comes from CO<sub>2</sub> reacting with the surrounding rock. This concept requires porous bedrock for allowing the injection of CO<sub>2</sub>. However, many types of rocks containing magnesium silicates and calcium silicates are highly crystalline and have practically no pore space. In *ex situ* carbonation the mineral would therefore be mined and processed with CO<sub>2</sub> in a separate plant, producing carbonate minerals and silica (Figure 3.9). The products could be disposed of as mine filler materials or possibly used for other industrial purposes. Since carbonation securely traps CO<sub>2</sub>, there would be little or no need to monitor the disposal sites. Based on the number of research articles and patents available, much more attention has been given to *ex situ* carbonation (Sipilä et al., 2008).

The current bottleneck for the development of mineral carbonation is the carbonation process. Natural carbonation of calcium and magnesium silicates occurs on a geological time scale due to their low reactivity with CO<sub>2</sub>. Therefore, the carbonation process must be accelerated considerably, using heat, pressure, as well as chemical and mechanical treatment of the mineral. Also, the reactivity of the minerals varies from case to case, and process solutions tend to be very mineral specific. Except for processes using industrial residues, no carbonation process using minerals has so far reached the pilot stage.

For large-scale CO<sub>2</sub> mineralisation of magnesium silicates the process concept developed by the National Energy Technology Laboratory (NETL) in Albany, U.S., is still the most successful one. In this process, a slurry of water and pre-treated mineral is reacted with pressurised carbon dioxide (40–150 bar) at a temperature of 100–185°C to produce magnesium carbonate and silica. However, the process is very energy demanding, since it requires fine grinding of the mineral to increase its reactivity, and in some cases heat treatment of the mineral. A feasibility study, based on a comprehensive set of experiments performed at NETL, presented minimum operating costs of 80 US\$ per t CO<sub>2</sub> avoided using olivine as feedstock, 112 US\$ per t CO<sub>2</sub> avoided using wollastonite as feedstock, and 300–500 US\$ per t CO<sub>2</sub> avoided using serpentine as feedstock (Gerdemann et al., 2007). The energy requirements for this process are 3.6–8.8 MJ/kg CO<sub>2</sub> stored using serpentine and 2.3–2.4 MJ/kg CO<sub>2</sub> using olivine. However, the study excluded CO<sub>2</sub> capture and transport costs as well as capital costs for processing equipment. On the other hand, the costs for heat treatment of serpentine seem to be overestimated, because the same costs were assumed for both heat

### 3. CCS technologies suitable for Nordic conditions

and power. Recalculated cost figures for serpentine indicate that the cost for carbonation of serpentine should be similar to those for olivine or wollastonite (Sipilä et al., 2008).

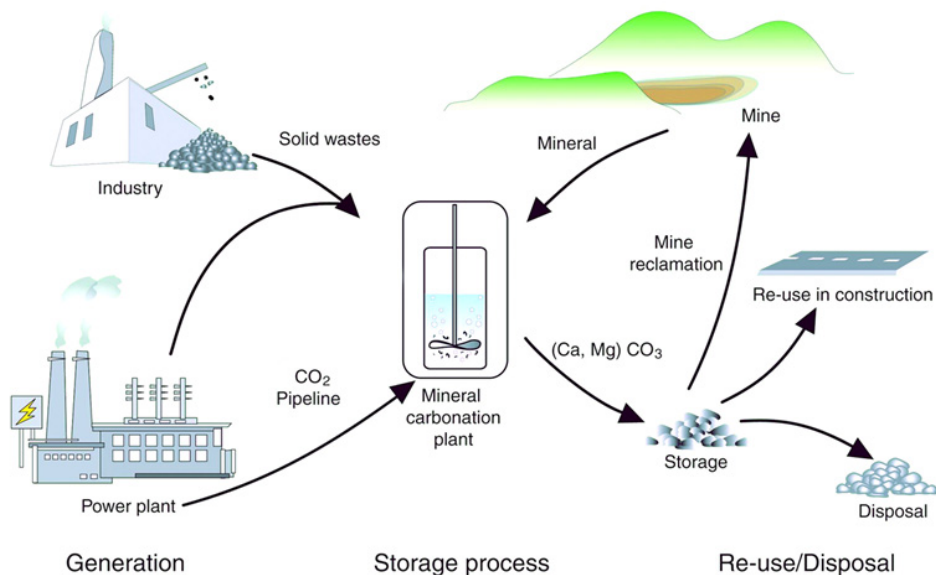

Figure 3.9. The concept for *ex situ* mineral carbonation (IPCC, 2005).

During the last years, there has been an increased activity in mineral carbonation R&D. Shell and Caterpillar have started developing their own mineral carbonation processes, which allow CO<sub>2</sub> in the flue gas to be mineralized without a separate capture step (Verduyn, 2010). Also, 20 new patents on mineral carbonation processes have been filed since 2004, with only 6 patents in total being filed before 2004 (Torróntegui, 2010). Unfortunately, according to our knowledge there have not been any public techno-economic evaluations of these processes yet. An overview of recent patents and publications in mineral carbonation is currently being prepared at Åbo Akademi (Zevenhoven, 2010).

A few interesting mineral carbonation processes are studied in the Nordic countries. In Åbo Akademi in Finland, a multi-step carbonation process for serpentine, using a pressurized fluidized bed reactor, is currently under development (Figure 3.10). The energy requirements for the process has been assessed to be from 6.1 MJ/kg CO<sub>2</sub> for a 75% overall carbonate conversion to 4.7 MJ/kg CO<sub>2</sub> for a 90% overall carbonate conversion. So far, a 97% extraction and 50% carbonation at 20 bar have been achieved using serpentine (Zevenhoven, 2010;

Fagerlund et al, 2010). In Iceland, an ongoing project (CarbFix) studies the possibility to inject CO<sub>2</sub> into aquifers in basaltic rock for in situ mineralization of CO<sub>2</sub> (see Chapter 4.3.3).

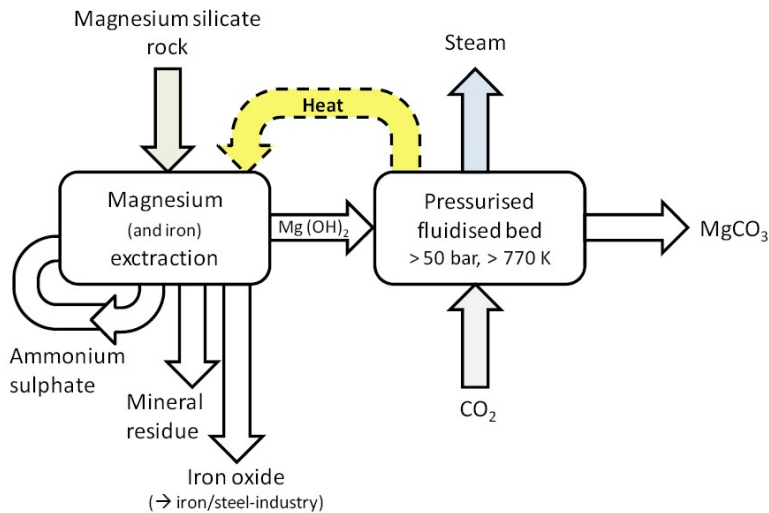

Figure 3.10. A multi-step carbonation process for serpentine (Zevenhoven et al. 2010).

### 3.4 CO<sub>2</sub> capture applied to combined heat and power (CHP) plants

Although most research and development has been put into CCS applications for condensing coal-fired power plants, combined heat and power applications could offer advantages for applying CCS, but there would also be drawbacks. Low quality heat streams available from auxiliary processes can be utilised more efficiently and thus the overall efficiency loss of a CHP plant with CCS is lower compared to a condensing power plant with CCS. Steady heat demand enables longer yearly uptimes in comparison to condensing power plants, which might provide a basis for better economy. Also, the sizing and dynamics of CCS processes are more straightforward because of the steady operation mode of CHP plants. The application of CCS in a plant connected to a district heating network will have impacts on its merit order in the energy system, and thus the total effect on CO<sub>2</sub> emissions of the energy system as a whole should always be consid-

ered. For example if heavy fuel oil-fired boilers are used to comply with the lowered efficiencies, the result of the emissions of the entire system might not be reduced. It is also possible that integration of CO<sub>2</sub> capture at a CHP plant would be more difficult than that for a condensing power plant. CHP plants are also often smaller than condensing plants. Applying CCS on CHP plants reduces the electricity output and increases the heat output, thereby decreasing the electricity production potential (Gode and Hagberg 2008).

## 3.5 Carbon capture in process industry

Industries such as iron and steelmaking, pulp and paper, cement and chemical plants represent a significant share of the large point sources of CO<sub>2</sub> in the Nordic countries. Process gases in certain industrial applications might even have higher concentrations of CO<sub>2</sub> that are more suitable to CCS than that of the power sector. CO<sub>2</sub> capture from industrial processes has not generally been widely studied.

Iron and steelmaking industry has no real alternatives for utilising coal as a raw material, at least not for all applications. Biochar and electric arc furnaces are often mentioned as solutions, but these are not applicable to all applications. They are also expensive or not technically ready for application. Oxygen-blown blast furnaces are most often mentioned as possible solutions for reducing CO<sub>2</sub> emissions from steelmaking. Emissions could also be lowered with DRI (direct reduced iron). The technology is based on a blast furnace utilising purified oxygen and recycling the top gas. It is currently in the development phase and has not been demonstrated yet. Pre- and post- combustion solutions could also be applied to process and flue gases of steelmaking processes. The CO<sub>2</sub> concentration in some of the streams is higher than in power plant applications, which could give some advantage. However, the large amounts of gas streams to be treated and the restricted availability of heat are limiting factors in applying “conventional” CCS technologies to iron and steelmaking.

Cement manufacturing generates substantial amounts of CO<sub>2</sub>. Emissions originate from the fuels burned in the kiln, and these account for around 40% of the CO<sub>2</sub> emission. The decomposition of limestone during the calcination process accounts for the remaining 60%. Consequently, even if sufficient biomass fuel sources were available to reduce the fuel component to a net emission of zero, the total emissions of CO<sub>2</sub> would only be reduced by ~40%. There are two

potential techniques that could be applicable for capturing CO<sub>2</sub> from cement industry: post-combustion and oxy-fuel combustion. Pre-combustion capture would only remove CO<sub>2</sub> emissions originating from the fuel.

Many fuel refining processes assort well for carbon capture. To this date, CCS has mainly been applied in natural gas production, where CO<sub>2</sub> is removed from natural gas for purification of the natural gas. Oil refineries also have relatively pure CO<sub>2</sub> streams that are already in some cases sold as by-products for industrial use, such as the removal of CO<sub>2</sub> from syngas in hydrogen production (via steam-methane reforming). In steam cracking, where high-temperature furnaces are used, the only feasible option is chemical absorption since the residual gas is a mixture of methane and hydrogen and has a low content of CO<sub>2</sub> concentration. The main CO<sub>2</sub> emissions from oil refineries originate from process heaters. It has therefore been suggested that oil refineries could be equipped with high-temperature CHP units with CO<sub>2</sub> capture (IEA, 2008). Also production of Fischer-Tropsch diesel can offer possibilities for cost efficient capture, since such production process already produces gas streams consisting mostly of CO<sub>2</sub> as by-products.

CCS could also be applied in the pulp and paper industry. Recovery boilers in the pulping process are the largest point sources of CO<sub>2</sub> in the pulp and paper industry, and many of them have annual emissions exceeding 1 Mt CO<sub>2</sub>, mainly in Finland and Sweden. Recovery boilers combust “black liquor”, which is an aqueous solution of lignin residues, hemicellulose, and the inorganic chemicals used in the pulping process. The black liquor contains more than half of the energy content of the wood and is combusted to recover sodium hydroxide and sodium sulphide, which is used to separate lignin from the cellulose fibres needed for papermaking. Strong chemicals present in the combustion causes higher level of impurities in the flue gases, which may make CO<sub>2</sub> capture more difficult and costly. Since the current EU Emission Trading Scheme (ETS) for CO<sub>2</sub> emissions does not include CO<sub>2</sub> originating from biomass, there are currently no economic incentives for applying CCS to recovery boilers. However, very few studies have been made on this topic.

### **3.6 CCS retrofit and capture-ready power plants**

Owing to the high fuel penalty combined with the rather low efficiency of older power plants, the option for retrofitting post-combustion capture techniques is deemed less encouraging. The same amount of energy is required for capturing

### 3. CCS technologies suitable for Nordic conditions

CO<sub>2</sub> at a certain concentration in from a flue gas stream, regardless of the net power output of the power plant. Therefore, the lower the efficiency of the power plant is, the higher the relative efficiency penalty is when applying CCS.

For instance, if the capture process to be retrofitted causes a 10%-point drop in efficiency, the net efficiency of a state-of-the-art coal-fired power plant with an efficiency of 47% would drop to 37%, while the efficiency of an old coal-fired power plant with an efficiency of 30% would drop to 20%. Assuming that the net power output from both is 500 MW<sub>e</sub> before capture, applying CCS would reduce the power output of the state-of-the-art to 394 MW<sub>e</sub> and that of the old power plant to 333 MW<sub>e</sub>.

The implication is that it is rather detrimental to retrofit plants that per se are not sufficiently efficient at the outset. In order to make a reasonable fit, it is necessary to start with a highly efficient power cycle with a relatively large plant size, and to make a high degree of process integration in order to limit the fuel penalty as much as possible.

As a large number of power plants are reaching the end of their lifecycle (probably) before CCS could be fully commercialised, a notion of “capture-ready” has been proposed. This implies that once a power plant investment decision has been made the power plant design should include the possibility to add CCS at a later stage. This would require that the following issues are taken into consideration (IEA GHG, 2007):

- a study of options for CO<sub>2</sub> capture retrofit and potential pre-investments
- providing sufficient space and access for the required additional CO<sub>2</sub> capture facilities
- identification of reasonable route(s) to the storage site for the captured CO<sub>2</sub>.

Industrial processes could also be retrofitted with CO<sub>2</sub> capture, for instance by installing capture units at the flue gas stream (similar to post-combustion capture for power plants). Depending on the industrial process, carrying out a CCS retrofit can be more complicated than that for power plants. On the other hand, some processes (for instance Fischer-Tropsch diesel production) could provide opportunities for easy CCS retrofit. Also, most capture processes require access to steam or heat for regenerating the capture agent, which increases the energy consumption of the industrial process significantly.

### 3.7 CO<sub>2</sub> capture from biomass-fired installations

Because biomass binds carbon dioxide in photosynthesis, carbon capture from biomass fired installations would lead to negative emissions on a life cycle basis. That would result in removing CO<sub>2</sub> from the carbon cycle and, thus, also the atmosphere. Generally the same technologies that are planned to be used with fossil fuels would be applicable also to biofuels.

Due to their small scale, plants combusting only biomass are not considered primary candidates for CCS application. The most viable application for power plants would be via co-firing of biomass with fossil fuels, like coal or peat in order to increase the plant size and thereby the efficiency of such plants. Several forest industry installations in pulp mills and integrated pulp and paper mills could be of interest as large point sources or clusters of biogenic CO<sub>2</sub> emissions to be subjected to CCS (see Chapter 3.5).

Current policies for lowering greenhouse gas emissions do not recognise negative emissions from power plants, and thus no fiscal incentive exists for capturing CO<sub>2</sub> from biomass installations. E.g. the ongoing EU-ETS does not take negative emissions into account.

### 3.8 Maturity of CCS

The maturity of prevalent CCS concepts and their development potential is identified in Table 3.2.

The reason for claiming “low” readiness for application of:

- oxy-fuel combustion (of natural gas) is the lack of gas turbines breathing oxygen instead of air, as natural gas offers a direct approach, which means that the flue gas itself makes the process medium via a gas turbine – in contrast to steam cycles that are used with coal (indirect approach)
- CLC with coal and natural gas is the lack of suitable oxygen carriers and also the early stage of development of such schemes for power generation.

On the other hand, both oxy-fuel combustion and CLC have a high development potential – especially with coal, which is also the case with IGCC. If the development of combustion chambers for gas turbine allows a rather high hydrogen concentration, it is expected that the combined cycle of the IGCC may offer a competitive advantage over post-combustion schemes, and be on par with oxy-

### 3. CCS technologies suitable for Nordic conditions

fuel combustion (and CLC) in the medium-long term. Still post-combustion schemes have a significant development potential, and it is decisive to bring forward research on related techniques because of the large reduction potential in industrial process that are prone to go via absorption techniques – similar to those of post-combustion capture in the power sector.

Table 3.2. Readiness for application and further development potential of alternative capture processes using coal and natural gas as feedstock.

<b>Technology</b>	<b>Readiness for application</b>		<b>Development potential</b>	
	<b>Coal</b>	<b>Natural gas</b>	<b>Coal</b>	<b>Natural gas</b>
<b>IGCC-CCS</b>	Medium–High	N/A	High	N/A
<b>Oxy-fuel combustion</b>	Medium–High	Low	High	Medium–High
<b>CLC</b>	Low	Low	High	Medium–High
<b>Post combustion</b>	High	High	Medium-High	Medium–High

### 3.9 Future improvement of CCS technologies

Figure 3.10 illustrates the impact of efficiency and capture rate (CR) on emission index (in g/kWh) for coal and natural gas. The European Parliament has proposed a level for clean energy at 500 g/kWh. With natural gas without CCS the emission will be termed clean if efficiency is higher than 42% (LHV), and similarly with bituminous coal with 25% capture rate if efficiency likewise were 42%. Hence, the figure clearly indicates that high efficiency is one important component of any strategy intended for reducing emissions of CO<sub>2</sub>.

The major efficiency penalty with CCS is caused by a) *the CO<sub>2</sub> capture process* – accounting for typically 5–8%-points depending on technology, coal and power cycle<sup>9</sup>, and b) *the compression train* – accounting for typically 3–4.5%-

---

<sup>9</sup> A non-integrated ASU may account for as much as 7–10%-points (with O<sub>2</sub> production of high purity; 99.5%).



points (or even more), depending on coal properties, power cycle<sup>10</sup>, capture rate and transport requirement.

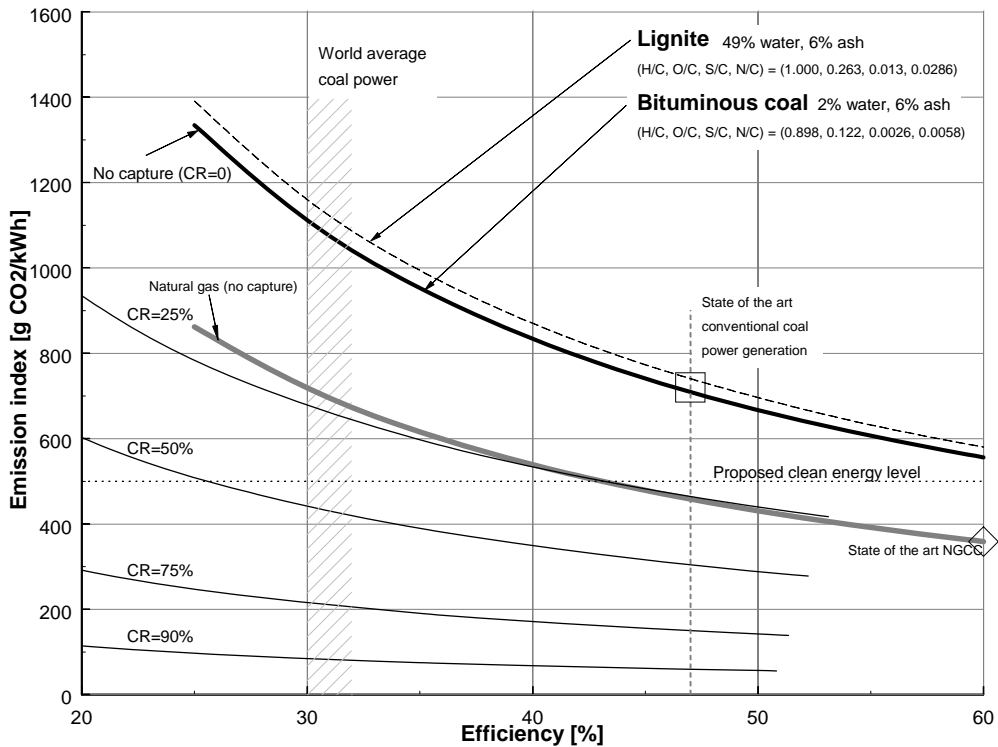

Figure 3.11. Emission index versus efficiency relating to a typical bituminous coal (solid lines) with various capture rates for CO<sub>2</sub> (CR). The chart also includes the trajectories of lignite and natural gas (both without CO<sub>2</sub> capture). In this chart the capture unit is assumed to account for 6% of the efficiency penalty, whereas the penalty owing to compression is determined by fuel and capture rate.

Power cycle improvements at various levels including alternative ways of making use of fuels and oxidants (either via gasification or by oxy-fuel combus-

<sup>10</sup> Presumptions: Pure CO<sub>2</sub>, 4 stage compression; Isentropic efficiency [82, 82, 80, 75]%; Initial pressure 1.5 bar; End-pressure 70 bar (ambient temperature ~20°C); Inter-cooling (with 3% pressure loss each stage).

### 3. CCS technologies suitable for Nordic conditions

tion) are emphasised in current research and development work. This includes studies on how to trap the tail-end CO<sub>2</sub> from the flue gas with the lowest practical and affordable efficiency drop (via adsorption or absorption) – combined with emerging techniques. Efficiency improvements are mostly sought within the capture system and the degree of integration thereof with the power cycle. This narrows down the (theoretical) potential for efficiency-drop improvement to a range of 5–8%-points efficiency.

The potential for further development can be derived from the trajectory of the thermal plant efficiency as depicted in Figure 3.12. The trend indicates a quite promising leap of around 4%-points awaited in just a few years owing to new material properties for steam cycles. The chart also recognises a highest plant efficiency of 47% (LHV, dry), which corresponds to the Danish Nord-Jyllandsværket. This high efficiency is achieved by combining advanced steam parameters, and a low end-point of the expansion line of the low-pressure turbine. The latter is obtained by using cold sea-water for condenser cooling. A similar system with air-tower cooling would have a net efficiency typically 1–2%-points lower.

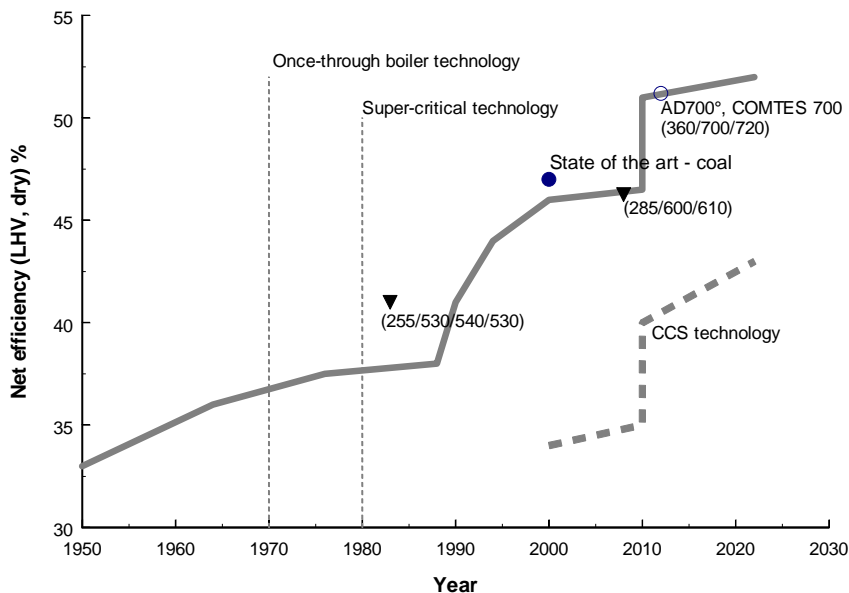

Figure 3.12. Trajectory of coal-power plant efficiency by recent year, and expected development owing to new materials for ultra-super-critical technologies and the expected set-back owing to CCS.

The awaited leap in efficiency (Figure 3.12) owes to ongoing research in advanced materials in the USA and Europe, which targets advanced materials to enable ultra-super-critical power generation (USC-PC) for new steam cycles to reach 360 bar and 700/720°C (superheat and reheat respectively) (Otter 2010, Vanstone 2005). The commercialisation of these materials is expected to match with the timelines of emerging CCS concepts up to year 2020. This means that a net efficiency around 50% can be regarded a realistic level for reference of conventional USC-PC. Conversely, the impact on USC-PC-CCS is indicated by the broken line at the lower right-hand area of the figure. This implies that net thermal plant efficiency (LHV, dry) is likely to be boosted from some 35–37% (current state of the art) to some 40–43% (or even more) by 2020.

## **3.10 Selection guidelines for sector-wise appliance of CCS**

There are many issues to consider when choosing technology for CCS applications. Since optimal solutions are generally application and case specific, significant techno-economic case-specific assessments are always required. Detailed level case studies are out of scope of this study. Instead, a summary of general selection criteria for CCS applications is presented, as well as summaries of how CCS can be applied in various industrial applications.

### **3.10.1 General selection guidelines**

Crucial aspects to handle when considering CCS are capture (and compression), transport, storage, monitoring, risk assessment, legal and regulatory framework, and last but not least the financial aspects pertaining to deployment of CCS at large scale. Below a brief mention is given to each aspect in order to put them into a more holistic perspective:

- Conventional capture technologies for CO<sub>2</sub> removal from a gas stream via chemical absorption or physical adsorption have been used in industry for decades. The major challenges of transferring these techniques to the power sector owe to differing physical dimension (especially in post-combustion capture), fuel penalty and cost of electricity. Although post-combustion technology is currently the technology closest to being realised in the scale required for power plants, future technological advancements in pre-combustion and oxy-fuel combustion are likely to

### 3. CCS technologies suitable for Nordic conditions

make these technologies competitive, at least for power plants.

- Use of process water and the residual solid waste (i.e. ashes from coal) are matters to be evaluated when considering technologies for the power sector. Especially post-combustion flue-gas cleaning may demand significant amounts of process water if a neutral water balance cannot be achieved (Hetland et al., 2009, Kvamsdal et al., 2010).
- Guidelines for the practical level of impurities in the captured CO<sub>2</sub> are given by previous European projects (especially ENCAP and later DYNAMIS), and are about to be conceived as an industrial “standard” These guidelines are recommended to be used in the Nordic countries as well (See Table 3.3).
- For safety reasons as well as for technical and economic grounds it is deemed important not to exaggerate the purity levels – especially in terms of free water (neither towards the lower end nor towards the upper end). Equipment, e.g. pipeline design specifications should be consistent with the tolerable concentrations of impurities, particularly water content, hydrogen sulfide (H<sub>2</sub>S), oxygen, hydrocarbons.
- With large quantities, pipeline transport is by far the prevalent means for CO<sub>2</sub> transport (for short to medium distances), but in a Nordic setting ship transport may turn out to become more feasible owing to distance and geographical constraints. As the cheapest and most feasible transportation mode should be chosen, it is important to assess alternative options and optimise for each case. Existing industry experience and regulations for pipeline design and operation should be applicable to future CCS projects.
- A suitable geological site for long-term storage of CO<sub>2</sub> must have the required capacity and it must comply with certain characteristics such as: effective trapping mechanisms, adequate storage capacity, and appropriate injectivity, as the latter will define the number of well. Potential storage reservoirs should be ranked using a set of criteria developed to minimise the risk of leakage. Future work is needed to clarify such ranking criteria.
- Depleted/depleting oil and gas fields have some attractive features in consideration of possible storage reservoirs: Mainly, the exploration cost would be lower; the reservoirs would be proven traps and known to have held liquids and gases for millions of years; and (quite importantly) injecting CO<sub>2</sub> into such reservoirs offers the potential for boosting the

oil/gas production (enhanced oil/gas recovery, or just EOR/EGR).

- In order to fully characterize a new reservoir (e.g. an aquifer) after seismic shooting, another 4–5 years are required at the best – including proper drilling/testing. The time lag for qualifying sites should be regarded the critical path of most projects.
- Continued monitoring during the closure period should be conducted in some wells in order to demonstrate low risk. It is well understood, however, that owing to the trapping mechanisms the security will increase significantly over the post-injection period as indicated in Figure 3.8. Hence, it is assumed that after some 40–50 years only sporadic checking would be required.
- Geological storage of CO<sub>2</sub> is seen as the major risk factor. For all storage projects risk assessment is required. As a minimum, risk assessments should include the examination of possible out-leaks of injected or displaced fluids via wells, faults, fractures and seismic events, and the fluids' potential impacts on the integrity of the confining zone and potential hazards to human health and the environment.
- Most CCS projects will operate without or with (only) little commercial benefits, so the demonstration projects will much depend on significant financial and political support from the regulators. A consortium of several entities and nations would be recommended (as appropriate) – including players (also) outside the Nordic countries.
- In order to attract investors for engagement in demonstration projects, policymakers should carefully consider options for design and application versus a reasonable framework of risk management. Relevant policy considerations should then be appropriately balanced against financial assurances and possible barriers.

### 3. CCS technologies suitable for Nordic conditions

Table 3.3. CO<sub>2</sub> quality recommendations from the EU-projects ENCAP and DYNAMIS (de Visser et al. 2008; Hetland et al. 2008b).

<b>Component</b>	<b>Concentration</b>	<b>Limitation</b>
H <sub>2</sub> O	500 ppm	Technical: below solubility limit of H <sub>2</sub> O in CO <sub>2</sub> . No significant cross effect of H <sub>2</sub> O and H <sub>2</sub> S, cross effect of H <sub>2</sub> O and CH <sub>4</sub> is significant but within limits for water solubility.
H <sub>2</sub> S	200 ppm	Health & safety considerations
CO	2000 ppm	Health & safety considerations
O <sub>2</sub>	Aquifer < 4 vol%, EOR 100–1000 ppm	Technical: range for EOR, because lack of practical experiments on effects of O <sub>2</sub> underground.
CH <sub>4</sub>	Aquifer < 4 vol%, EOR < 2 vol%	As proposed in ENCAP project
N <sub>2</sub>	< 4 vol% (all non condensable gasses)	As proposed in ENCAP project
Ar	< 4 vol% (all non condensable gasses)	As proposed in ENCAP project
H <sub>2</sub>	< 4 vol% (all non condensable gasses)	Further reduction of H <sub>2</sub> is recommended because of its energy content
SO <sub>x</sub>	100 ppm	Health & safety considerations
NO <sub>x</sub>	100 ppm	Health & safety considerations
CO <sub>2</sub>	> 95.5%	Balanced with other compounds in CO <sub>2</sub>

## **4. Capacities for carbon dioxide storage in the Nordic countries**

The objective of this section is to give a brief mapping of the storage resources in the Nordic countries. For geological storage, mapping is made both with respect to the total capacity and mature capacity. A qualitative analysis of various methodologies is made for assessing the accuracy of the various methods for providing information on the maturity of the resources for practical storage in a specific time perspective. The emphasis is put on the more mature storage resources. An overview of the potential for CO<sub>2</sub> storage by mineral carbonation is also given.

### **4.1 Data background and methods**

In this section, the storage capacity of CO<sub>2</sub> in the Nordic countries is mapped including aquifers and depleted gas reservoirs. Oil reservoirs are not included, but these may provide a significant additional capacity whether CO<sub>2</sub> injection is combined with EOR or only applied in depleted formations simply as storage projects. Underground storage normally requires sedimentary rocks with some porosity. These are available in the Nordic region offshore and onshore, although not in all Nordic countries. An approximate extension of the sedimentary rock in the Northern Europe is illustrated in Figure 4.1. Except for Denmark and some areas of south Sweden, most of the potential is located offshore (the northern part of the Nordic countries and Iceland are not shown, but this will not change this picture). The capacity assessment can therefore be converged to cover the Nordic part of the North Sea, Skagerak, Kattegat, the southern Baltic Sea, onshore Denmark as well as Skåne, Öland and Gotland in Sweden.

#### 4. Capacities for carbon dioxide storage in the Nordic countries



Figure 4.1. The sedimentary basins of Northern Europe as indicated by the orange colour (Vangkilde-Pedersen *et al.* 2008).

##### 4.1.1 Methodology for aquifers

A few studies on aquifer storage potential partly covering the Nordic countries have previously been performed. In the Joule II project “Underground Disposal of Carbon Dioxide” (Holloway *et al.* 1996) estimates for Denmark and Norway were included. In this study a general method for estimating resources in aquifers was introduced. It is a simple volume estimate of the pore volume based on area and average thickness of the aquifer corrected for porosity and net/gross ratio. The final volume is then multiplied by an efficiency factor (typically between 0.01 and 0.06). However, the scientific basis for this factor is weak. This method has later been used in several other studies, *e.g.* Bøe *et al.* (2002) in the GESTCO project. Some other criteria for aquifer storage as depth and permeability were also applied. In this study the minimum size of any target must economically justify the drilling of at least one injection well.

This type of estimates does not include the quality of the sealing structure where a lack of integrity may limit the storage capacity or other dynamic proper-



ties or pressure limitations. The pressure build-up may strongly limit the storage capacity if it is not effectively handled.

As a first estimate this method provides a simple and quick estimate for potential resources and data based on this method will also mostly be adopted in this study. For more mature formations, however, more accurate methods are required based on actual reservoir behaviour of dynamic processes or simulation injection, where both detailed distribution of CO<sub>2</sub> and pressure build-up are taken into account.

In virgin aquifers at hydrostatic pressure there is another complicating factor that has to be taken into account. If no previous storage experience exists it is almost impossible to provide sufficient exploration data to give an accurate description of the sealing capacity of the cap rock. Seismic surveys can give good description of the topography and in some cases thickness of the sealing structure, but it can not always reveal fractures or crumbled zones that may constitute risk for leakage. Even faults may be undetected if they are not associated with large offsets. Information from well logs can give very accurate data on the quality of each specific stratum down through the underground. Also core samples can be extracted from the wells. Laboratory studies of the core samples give the most accurate properties. In practice, however, the number of exploration wells will be limited and the information from these are just like needlepoint samples of a large surface. The area of the Utsira formation is approximately 25 000 km<sup>2</sup> and even if there exist hundreds of well logs from the formation, simply to interpolate the properties between the wells could overlook that there may exist leaking structures between the wells. Actually no exploration by geophysical methods or wells can provide accurate information about the integrity of the cap rock over large areas. The performance of the cap rock will only be revealed when injection starts and improved estimates of the target formation will be possible to make when performance data based on monitoring are available.

#### 4. Capacities for carbon dioxide storage in the Nordic countries

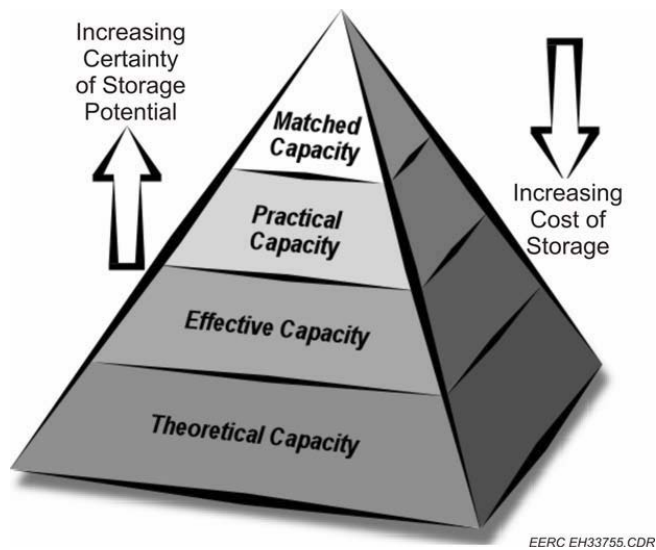

Figure 4.2. The CSLF resource pyramid (Bachu et al. 2007).

There are different methods to classify the storage resources in terms of criteria to identify the total capacity of more or less prospective sites. The resource pyramid (Figure 4.2) presented by the Carbon Sequestration Leadership Forum (CSLF) is a very simple model where each level in the pyramid represents additional constraints.

In this study much simpler criteria are used. Based on the discussion above the important step is to determine when enough data exists to approve injection. Sites with this quality constitutes the highest level, while well identified formations that need some further exploration in terms of larger physical operations (obtaining geophysical data or exploration wells) constitute the second level. The sites with the highest level of quality are referred to in this text as *mature* storage sites.

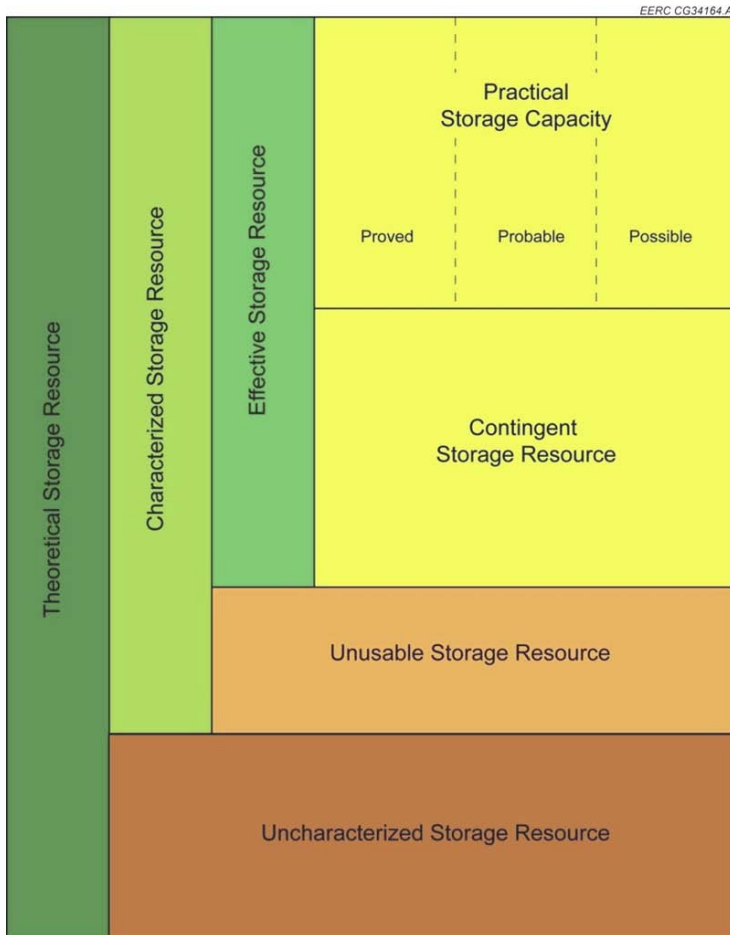

Figure 4.3. A modern classification system for storage resources of CO<sub>2</sub>.

#### 4.1.2 Methodology for depleted gas reservoir

For depleted gas reservoirs, the storage potential is very differently estimated, because a performance history exists. Also in these formations comprehensive monitoring has to be combined with simulation history to optimise the storage capacity. As an estimate of the storage capacity of depleted gas reservoirs the reservoir volume of previously produced gas gives a good basis and will always be much more accurate than the corresponding estimates for aquifers.

## 4.2 Capacity estimates

### 4.2.1 Storage capacity in Norway

Most of the best explored aquifers suitable for storage are located in the North Sea from Tampen in north to the Sleipner Area in the south (Figure 4.4). In this area some of the major gas and oil fields are also found, e.g. Statfjord, Gullfaks, Snorre, Veslefrikk, Oseberg, Troll, Frigg Heimdal Sleipner, and the area has been extensively explored with respect to petroleum. From this exploration a number of important aquifer systems has been found and characterised.

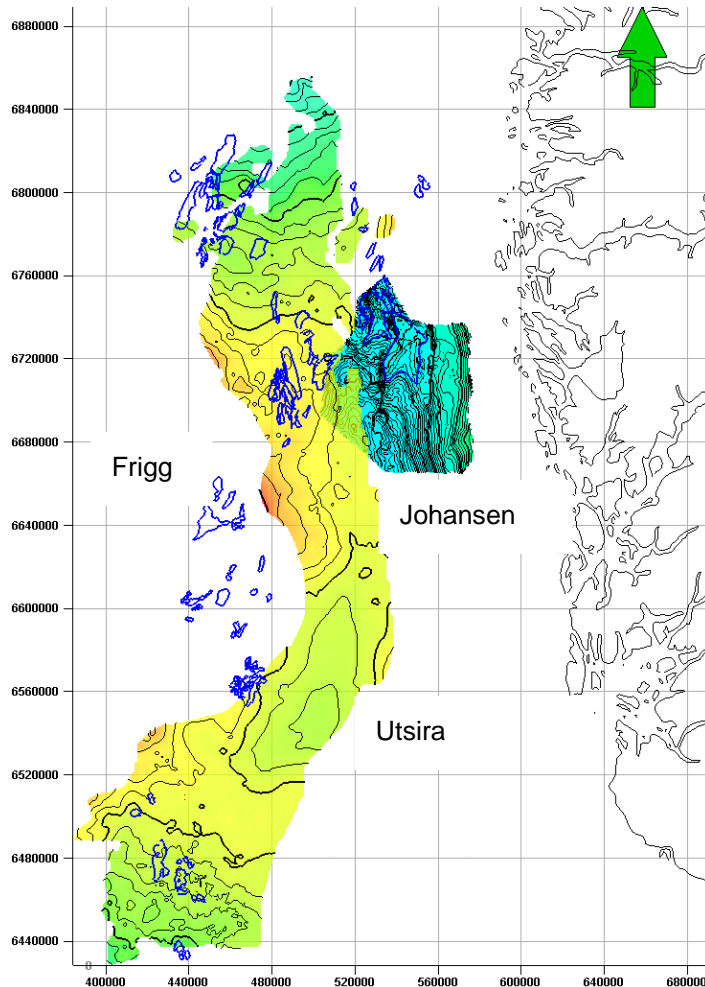

Figure 4.4. Important fields in the North Sea.

Bøe *et al.* (2002) has identified 28 formations in the southern and central North Sea on the Norwegian continental shelf. Only a subset of these has been selected here for discussion because some of these are not candidates for injection yet, due to interference with ongoing petroleum activity or because they are not yet sufficiently explored for the time perspective selected in this study (Table 4.1). Four of the sites will be discussed specifically.

Table 4.1. Storage capacity of the most prospective Norwegian sites. The numbers are from Bøe *et al.* (2002).

Formation	Age	Area (km <sup>2</sup> )	Average thickness (m)	Net/ gross	Porosity	Pore volume (km <sup>3</sup> )	CO <sub>2</sub> density (kg/m <sup>3</sup> )	Storage capacity Gt CO <sub>2</sub>
Utsira	Miocene- Pliocene	25000	150	0.7	35	918	769	42.4
Skade	Miocene	13000	120	0.7	32	349	719	15.1
Grid	Eocene- Oligocene	10000	140	0.6	28	235	623	8.78
Frigg	Eocene	2000	90	0.8	29	42	695	1.75
Heimdal	Paleocene	13000	180	0.6	28	393	652	15.4
Johansen	Early Jurassic	5 000	100	0.8	20	80	700	1.12

The *Utsira formation* constitutes a special role in the Norwegian CO<sub>2</sub> storage inventory. Not only has it been explored by several hundred exploration wells, but there are 2D and 3D seismic surveys from a large part of the 25 000 km<sup>2</sup>, which is usually considered as the Utsira formation (Figure 4.4). The most important feature of this formation is that the 14 years of CO<sub>2</sub> injection at the Sleipner Field has been very successful and carefully monitored by geophysical methods.

The Utsira formation is a thick, highly permeable, unconsolidated sand formation with an average thickness of 90 m. The thickness grows up to 350 m in the southern part, while it is thinning out towards the east. The sand is interbedded with a number of thin shales, but in the Sleipner area, where CO<sub>2</sub> has been injected for 14 years, the seismic monitoring of the CO<sub>2</sub> plume has shown that these shales have no strong sealing capacity: the CO<sub>2</sub> has reached to top of the structure only after three years of injection. The sand is a shallow marine deposit from the Early Pliocene and late Miocene (Rundberg and Eidvin 2005). The formation is thinning towards the east and is overlaid by a thick shale in the

#### 4. Capacities for carbon dioxide storage in the Nordic countries

Nordland group, which is typically 100 m thick and this shale provide the primary seal.

The capacity of this formation has been discussed, but the early estimates of approximately 40 Gt CO<sub>2</sub> (Holloway *et al.* 1996, Bøe *et al.* 2002) has recently been verified by more detailed reservoir simulations, where a number of injection wells (more than 200 in one scenario) distributed over most of the aquifer injected 133 million tonne over a period of 300 years (Lindeberg *et al.* 2009). The study showed that in order to control the reservoir pressure it would be necessary to produce water from the formation through an equal number of water production wells.

The *Skade formation* is located below Utsira. It occupies one third of the same area as the southern part of Utsira. The formation has some of the same reservoir properties as Utsira and the depth varies between 900 m and 1400 m. Similarly to Utsira it also is thinning towards the east. It is overlaid by thick shales from the Hordaland Group, but at some places there are continuous sand columns into the Utsira formation.

This may open for interesting injection scenarios for a combined utilization of the storage capacity of the two formations. In the study on large scale utilization of the Utsira formation mentioned above (Lindeberg *et al.* 2009) the big challenge was in investigating the placing of the water production wells so that CO<sub>2</sub> breakthrough from the injection well is minimized. This was solved by using many horizontal wells with a 500 m long horizontal perforation on the bottom of the formation. Injected CO<sub>2</sub> would still eventually reach the water production wells due to gas coning and this was considered to be the real limitation for the storage capacity in Utsira. Due to pressure communication between Utsira and Skade the water production wells could preferably be located in the bottom of Skade, which would delay water breakthrough and accordingly increase the storage capacity in Utsira.

Another option could be to inject CO<sub>2</sub> under the Hordaland shale in Skade and allow the CO<sub>2</sub> to migrate along the cap rock. When it reaches the spill point where the formations are connected, the CO<sub>2</sub> would start migration through Utsira, where it is finally trapped under the Nordland shale. The long migration path may disperse more CO<sub>2</sub> and give an increased contact area with the formation water enhancing the dissolution of CO<sub>2</sub> in brine. A combination of these two storage scenarios may also be applied.

The *Johansen formation*, located below the Troll gas field at approximately 200 m depth, is an interesting storage candidate, since it is only 80 km from

#### 4. Capacities for carbon dioxide storage in the Nordic countries

Mongstad, where there are large sources of industrial CO<sub>2</sub>. Another important feature is that if the formation would leak any CO<sub>2</sub> it would eventually only be trapped in the Troll gas field, which has a verified seal. The gas production from Troll will end by year 2060, so as long as no CO<sub>2</sub> reaches Troll before that year there will be no interference with the production from Troll. There have been several studies on the storage capacity of Johansen typically utilizing by a moderate injection rate compatible with the CO<sub>2</sub> sources in the local onshore region. For instance, Bergmo *et al.* 2008, have illustrated an injection scenario of 3 million tonne CO<sub>2</sub> per year over a 110 years time horizon. In Norway there is an ongoing discussion if there is sufficient reservoir data to start injection immediately or if another exploration well is needed. This attractive formation is included here, but it is on the borderline to qualify for the strict criteria for maturity defined in this study.

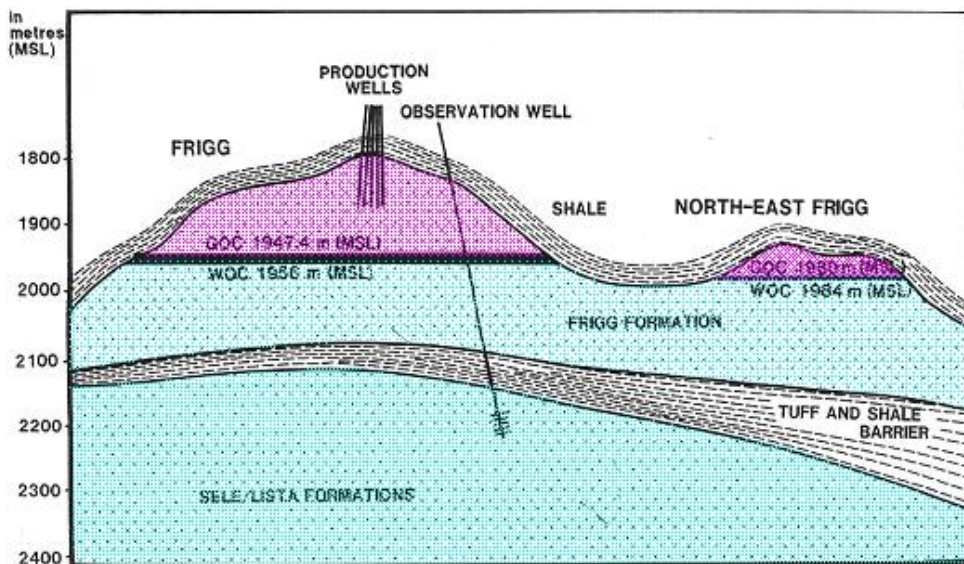

Figure 4.5. Simplified profile of Frigg and North-East Frigg.

*Frigg* is a depleted gas field divided by the Norwegian-UK boarder at approximately 1900 m depth. If the same reservoir volume of CO<sub>2</sub> could be stored as the reservoir volume of the produced gas this would be approximately 660 million tonne. Bøe *et al.* 2002 has, however, assumed that the aquifers below also could store a lot of CO<sub>2</sub> and the estimate is therefore much higher in Table 4.1. There

#### 4. Capacities for carbon dioxide storage in the Nordic countries

are actually several depleted fields in the area, but here they are discussed as one storage unit.

The gas production history has provided good knowledge on the dynamic properties of the formation and the site could therefore be considered as very mature for CO<sub>2</sub> storage. A verified sealing cap rock is also an important feature for evaluating the potential. There is, however, one complication if the pressure shall be controlled by water production. Below the gas cap there was initially an oil zone that was never produced. During depletion of the gas the oil was trapped by the invading aquifer. Most of this oil is immobilized, trapped as residual oil saturation, but if CO<sub>2</sub> is injected, it could be mobilized and possibly reach water production wells. This point must be taken into account if a robust injection strategy is being planned. There is possibly pressure communication between Frigg and the underplaying Sele/Listra formation and this could be utilized in various injection scenarios.

Another similar depleted gas field which is not discussed in detail here is *Heimdal* with a good characterized properties and verified seal.

There are also other regions on the Norwegian continental shelf that must be considered. The ongoing CO<sub>2</sub> injection in the Tubåen formation below the Snøvit gas field has given new information about the storage capacity. However, due to an unexpected fast pressure increase in the reservoir it cannot yet be assumed that the storage capacity is larger than needed for the Snøvit injection project itself. There may be other storage units in the region, but much more exploration would be needed to identify robust storage capacity.

In Mid-Norway also a few candidates have been identified and even studied in dynamic simulation studies. The geological input for these studies was sparse and the uncertainty in storage potential remains until more exploration data have been recovered.

What remain are three of the candidates listed in Table 4.1. As mentioned above, the capacity in the dynamic studies for Utsira was connected to a specific storage rate. Generally, with slower injection it is possible to achieve a larger utilization of the pore volume. There is, however, an external limitation to the injection rate. The fossil era will possibly last for only 500 years and longer injection scenarios have therefore no meaning in a CCS perspective. The weakness with static estimates as those in Table 4.1 is that this dynamic component is absent. A new method for estimating capacity is therefore suggested here connecting the capacity to rate.



The most prospective candidates selected from Table 4.1 are shown in Table 4.2, where injection rate is the basic parameter. The injection rates for Skade, Grid and Heimdal is just estimated by scaling from more detailed studies on similar formations. The rate is also much more important for planning infrastructure than the ultimate storage capacity. A typical infrastructure including long pipelines, injection and production well has a technical lifetime of maybe 25 to 40 years. The important parameter for planning is actually not the storage capacity for the whole fossile fuel era, but for the practical life time of the investment.

Table 4.2. Storage capacity of the most prospective Norwegian sites in term of injection rates.

<b>Formation</b>	<b>Injection rate Mtonne/year</b>	<b>Minimum injection period, years</b>	<b>Storage capacity<sup>2)</sup> Gtonne CO<sub>2</sub></b>
Utsira	133	300	42.4
Skade	35		15.1
Grid	15		8.78
Frigg <sup>1)</sup>	33	20	1.75
Heimdal	35		15.4
Johansen	3	110	1.12
<b>Total</b>	<b>254</b>		<b>84.55</b>

<sup>1)</sup> Norwegian part only

<sup>2)</sup> Ultimate capacity according to Bøe *et al.* 2002

The conclusion for the storage capacity in Norway is that the total capacity at present is approximately 250 million tonne CO<sub>2</sub> per year for a period typically much longer than the technical life time of the investments needed to utilize the capacity. This injection rate could be achieved without large exploration costs. This is significantly larger than the practical storage demand for the Nordic region and calls for cooperation with Nordic countries and countries on the European continent and the UK.

#### 4.2.2 Storage capacity in Denmark

Most of Denmark's subsurface consists of sediments (Figure 4.1). Most of these sediments are porous and may possibly provide sufficient retention time for CO<sub>2</sub> storage, if a sealing structure can be identified above them. In the EU project GeoCapacity, Anthonsen *et al.* (2008) have mapped some structures where sufficient data are available and which could be selected for future projects. The

#### 4. Capacities for carbon dioxide storage in the Nordic countries

structures with storage potential are illustrated in Figure 4.6. The basis for this data is good because the underground has been studied from numerous seismic surveys and wells.

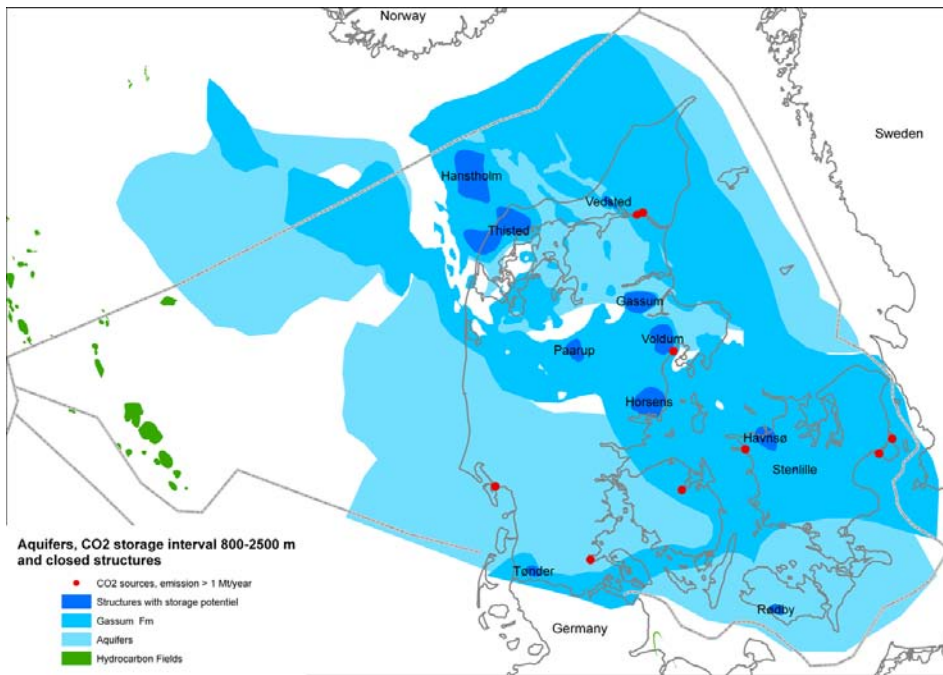

Figure 4.6. Denmark and surrounding aquifers (Anthonen *et al.* 2008).

The specific storage capacities for each of the identified structures are given in Table 4.3. In the GeoCapacity project a storage efficiency factor of 40% was used. This is very high and could only be achieved by gravity stable displacement of water in the formation and simultaneously production of water in the bottom of the reservoir. This will, however, require a very slow injection rate and will not be practical considering that the remaining fossil fuel era will only be maximum 500 years long. In this study, where only the most mature storage capacity is included, the efficiency factor has been reduced to 10% (Table 4.3). Lindeberg *et al.* (2009) have shown that a potential of up to 8% storage efficiency can be achieved in even a very flat aquifer (Utsira formation) with practical injection rates.

#### 4. Capacities for carbon dioxide storage in the Nordic countries

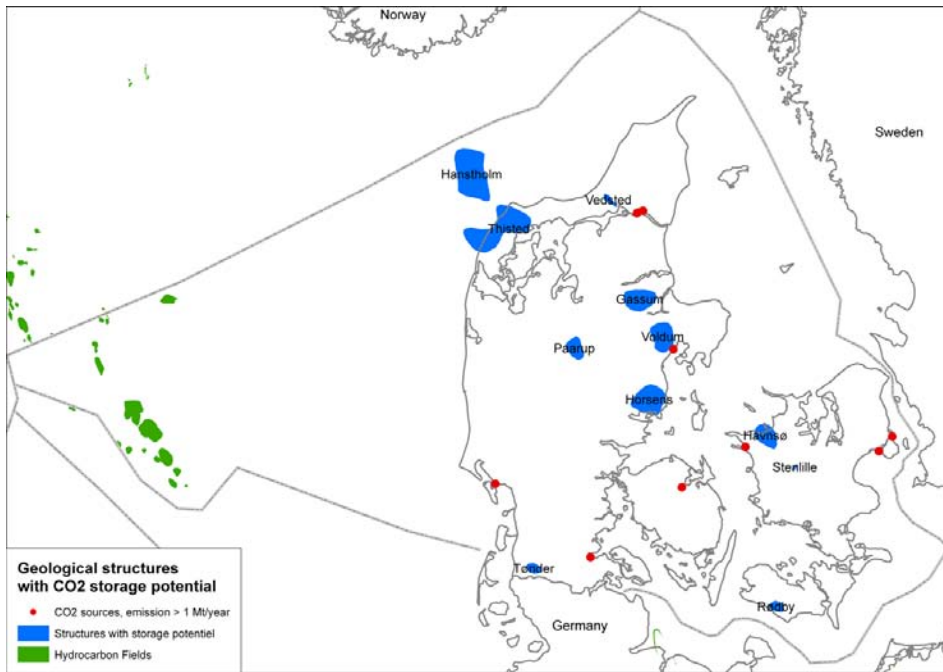

Figure 4.7. Specific Danish aquifers identified for CO<sub>2</sub> storage (Anthonen *et al.* 2008).

Table 4.3. Re-assessed mature storage capacity of onshore and offshore Danish aquifers.

Structure	Capacity million tonnes
Hanstholm	275
Gassum	63
Havnsø	93
Horsens	49
Paaup	9
Rødby	15
Stenlille	5
Thisted	1104
Tønder	9
Vedsted	16
Voldum	29
<b>Total</b>	<b>1667</b>

#### 4. Capacities for carbon dioxide storage in the Nordic countries

There are no depleted gas reservoirs in Denmark. As most Danish gas is associated gas from oil fields and these are not included in this study.

##### **4.2.3 Storage capacity in Finland**

In Finland all deep rocks are expected to be crystalline basement rock and not suitable for CO<sub>2</sub> storage. The same situation applies for the near Finland water in the Baltic Sea. The closest potential storage sites for Finland are the formations in the southern Baltic Sea, but these can not be considered Finnish territory. These formations are here covered in the paragraph on the Swedish storage capacity.

##### **4.2.4 Storage capacity in Iceland**

While Iceland has no deep porous sedimentary rocks, the island has several deep and shallow basaltic lava flows. These are much more reactive than other silicate rocks and may store CO<sub>2</sub> as CaCO<sub>3</sub> under certain conditions. In a large pilot project at the Hellisheidi geothermal power plant, CarbFix, this option is studied extensively by scientists from Iceland, France and USA (Alfredsson *et al.* 2008, Matter *et al.* 2009). The target injection formation at a depth of 400 to 800 m consists of basaltic lava flows and hyaloclastite. CO<sub>2</sub> storage in these types of rock for storage is also studied in other countries (*e.g.* India and USA), but the feasibility of the concept as a practical storage option is currently far from being established.

Despite the ambitious efforts in research and development it is too early to provide any storage potential comparable to the confidence which is guiding this study.

##### **4.2.5 Storage capacity in Sweden**

Most of Sweden, like Finland and onshore Norway, is covered by crystalline basement rocks, which are unsuitable for CO<sub>2</sub> storage. However, if the surrounding sea areas are included, sedimentary rocks cover a quarter of the bedrock surface (Figure 4.8). Large, continuous areas of sedimentary bedrock are only found in the south-west of Skåne and the southern and south-western Baltic Sea. Within these sediments there are two areas that meet the basic requirements for

#### 4. Capacities for carbon dioxide storage in the Nordic countries

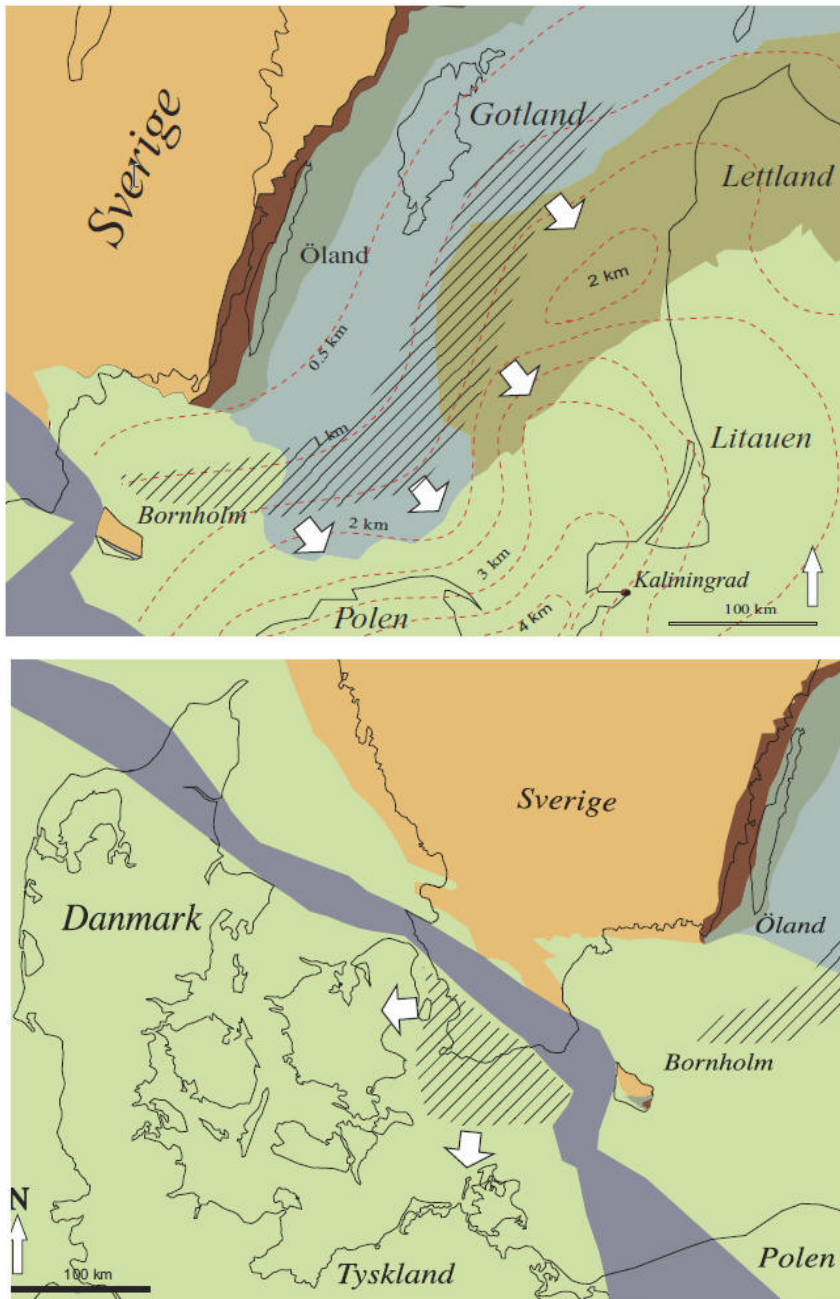

Figure 4.8. Sedimentary rocks in the southern Baltic sea and the south of Sweden. The light green colour represents rocks younger than Devonian, the tan area is Devonian and the light gray is from the Silurian age. The hatched areas are the most prospective from a storage point of view especially in term of reservoir properties (porosity and permeability).

#### 4. Capacities for carbon dioxide storage in the Nordic countries

storage. One is found in the Baltic Sea south of Gotland, where it stretches south towards the island of Bornholm and Poland and eastwards to the Baltic countries. In this area sandstone formations are found, which have been proven to contain oil and gas, particularly on the Baltic side. Porosity varies greatly in the formations, and is mostly low. Gas and oil traps found in the area are also very small in comparison to oil fields in the North Sea. Therefore, the storage capacity in this area is uncertain.

The second potential area consists of south-western Skåne and the adjacent southern sea area. Here are several sandstone formations at appropriate depth with high porosity and permeability. Deep bedrock structures within these areas are relatively well known, because of the oil and gas exploration that was conducted primarily during the 1970s. In Skåne, hot water from these formations is used in geothermal energy projects. The hatched areas in Figure 4.8 represent the most prospective areas and in all cases the storage formation are shared with other countries.

The sealing capacity of the overburden has, however, not been verified and significant exploration efforts are needed before storage estimates can be provided.

### 4.3 Suitable minerals for mineral carbonation

In order to provide for significant storage of CO<sub>2</sub>, large amounts of raw materials are required as feedstock for carbonation. Therefore, the raw materials used for carbonation must be abundant and cheap. Calcium and magnesium carbonates are poorly soluble in water and could in theory store CO<sub>2</sub> permanently. Magnesium and calcium oxides or hydroxides would be ideal materials for carbonation, but these are rare in nature. Instead, calcium silicates and magnesium silicates are the prime candidates for carbonation, since these materials are abundant in the Earth's crust. The theoretical storage capacity of silicate minerals has been estimated to 10 000–10 000 000 Gt of carbon (Lackner, 2003), which exceeds the amount of carbon in known fossil fuel resources. However, the realistic capacity is expected to be much lower.

*Ex situ* mineral carbonation would demand large amounts of materials: assuming 100% conversion and 100% ore grade, a minimum of 2–3 t of magnesium silicate mineral is required per t CO<sub>2</sub> stored, producing at least 3–4 t of carbonates and silica. In practice, the ore quality and carbonate conversion will be lower, raising the requirements for ore mining. In the feasibility study by Ger-

demann et al. (2007), the ore requirements ranged from 3 to 30 t per t CO<sub>2</sub> stored, depending on the maximum achieved conversion and the ore grade. Even if relatively pure mineral (e.g. 70–90%) was available, the amount of rock required for storage by mineral carbonation would be of similar magnitude as the current total mineral production in the Nordic Countries (Table 4.4).

Table 4.4. Annual production of mineral resources in the Nordic countries (excl. sand and gravel).

Source	Norway	Sweden	Finland	Denmark	Iceland
Production (t)	70 220 000 <sup>1</sup>	50 844 000 <sup>2</sup>	33 428 000 <sup>3</sup>	6 040 000 <sup>4</sup>	870 000 <sup>4</sup>

<sup>1</sup>NGU(2009), <sup>2</sup>SGU(2009), <sup>3</sup>TEM(2010), <sup>4</sup>USGS(2009),

#### 4.3.1 Calcium silicates

Although calcium silicates tend to be more reactive for carbonation than magnesium silicates, calcium silicates with high concentrations of calcium are relatively rare. Wollastonite, CaSiO<sub>3</sub>, has probably the highest calcium content of silicate minerals. For wollastonite, the carbonation reaction can be written as:



Wollastonite deposits of economic value are rare. The worldwide production of wollastonite is annually about half a million tonne, of which Finland, as a major wollastonite supplier, produces annually about 20 kt (Teir *et al.* 2005). The price of wollastonite ranges therefore from 50 US\$/t to hundreds of dollars per tonne. Although wollastonite is frequently mentioned as a possible raw material for CO<sub>2</sub> storage by mineral carbonation, it is obviously too rare and expensive to be considered for carbonation.

#### 4.3.2 Magnesium silicates

Magnesium silicate rocks are usually richer in base ions than calcium silicate rocks and distributed throughout the world. For instance, the Oman ophiolite could in theory store all CO<sub>2</sub> currently in the atmosphere (Kelemen *et al.*, 2008). Due to the high theoretical capacity of magnesium silicates, most of the research

#### 4. Capacities for carbon dioxide storage in the Nordic countries

into mineral carbonation has focused on these minerals, in particular olivine ( $\text{Mg}_2\text{SiO}_4$ ) and serpentine ( $\text{Mg}_3\text{Si}_2\text{O}_5(\text{OH})_4$ ). For olivine and serpentine, the carbonation reactions can be written as:

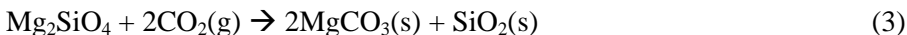

Olivine is used as a flux in iron ore smelting, increasing the production capacity of the smelting process. Olivine also replaces the carbonate mineral dolomite in steel production for slag formation, thus strongly reducing  $\text{CO}_2$  emissions released from carbonates. In order to be suitable for industrial purposes, olivine have to be of high grade ( $> 85\%$   $\text{Mg}_2\text{SiO}_4$ ). Olivine of high grade is, however, relatively rare.

Norway is one of the world's leading producers of olivine, producing a total of 3–4 million tonnes of olivine annually, mostly by North Cape Minerals from production sites at Åheim and Raubergvika in Møre og Romsdal, and Bryggja in Nordfjord in Sogn og Fjordane (NGU, 2009). The dunite bodies, from where the olivine is mined, are the largest in the world and estimated to contain 2 Gt of olivine within 6  $\text{km}^2$  (Kogel *et al.* 2006). Another potential producer in Norway is Steinsvik Olivin, which have 10 Mt of minable volumes of olivine (Steinsvik Olivin, 2010). Olivine is also found in Sweden, for instance in Rörmyrberget, Västerbotten, and Maniliden, southern Norrbotten (Åkerman, 2003).

Olivine consisting of less than 85%  $\text{Mg}_2\text{SiO}_4$  is considered unsuitable for most industrial uses, because the high iron content lowers its melting point. This non-commercial olivine is therefore a more likely raw material for future mineral carbonation application. However, little information on the resources of non-commercial olivine is available, since these resources have not previously been of interest.

The most common Finnish Mg rich rocks are ultramafic rocks, such as peridotites, dunites, hornblendites, pyroxenites, and komatiites, and their metamorphic varieties, i.e. serpentinites, talc, and asbestos rocks. Of these ultramafic rocks, the most interesting for CCS purposes are the serpentinites, because they consist mainly of serpentine. A detailed survey of Finnish ultramafic rocks suitable for carbonation has been made by Aatos *et al.* (2006). Millions of tons of poorly documented in situ or hoisted serpentinite or tailed serpentine deposits are situated mainly in central Finland. It has been estimated that the sequestering



#### 4. Capacities for carbon dioxide storage in the Nordic countries

capacity of the Outokumpu-Kainuu ultramafic rock belt is about 2–3 Gt CO<sub>2</sub> (Aatos *et al.*, 2006). Serpentine is also a common mineral in Sweden. Atoklinten, is a 1 km high mountain, consisting to a large part of serpentinite. Other notable occurrences are found in the Norberg mining district in Västmanland, Falu mine and Skyttgruvan in Dalarna, Taberggruvan in Småland and in many of the manganese mines in Värmland (Scandinavian mineral gallery, 2010).

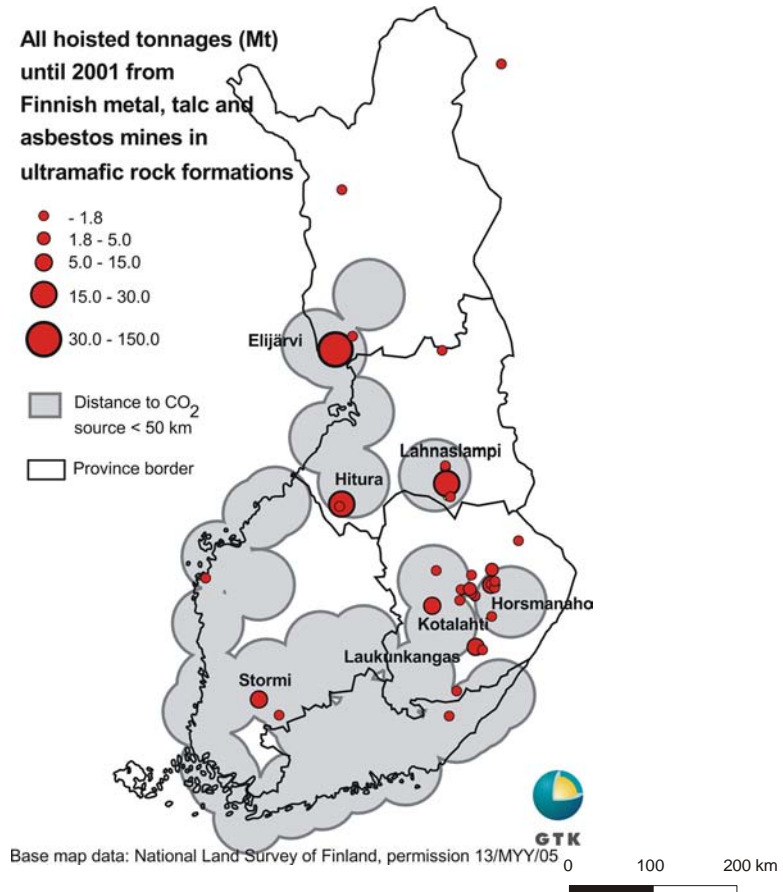

Figure 4.9. Possible sources of serpentinite in Finland. Circles mark areas where the distance to a major stationary CO<sub>2</sub> emitter is < 50 km (Aatos *et al.*, 2006; Teir *et al.*, 2006).

Rocks potentially suitable for carbonation are already mined, processed, piled, and stored at mines producing industrial minerals and metals, such as talc, soapstone, chromium, and nickel. Especially the countries located on the Fennoscandian

#### 4. Capacities for carbon dioxide storage in the Nordic countries

dian shield (Norway, Sweden and Finland) have a large output (Table 4.4). Nickel ore is usually located in or under olivine deposits (Åkerman, 2003.). A small amount of the hoisted ore is refined into commercially usable materials, while the remainder is left as waste rock or processed rock. The resources of hoisted serpentine and serpentinite (33–39% MgO) at contemporary Finnish nickel, chromium, and talc mines are at least 29 Mt (Figure 4.9).

One example is the Hitura nickel mine, where the main minerals are serpentine (antigorite), 80–90%, chlorite, calcite, and magnetite, 7–9% (Isohanni *et al.*, 1985). A large part of the mineral deposit is barren in nickel. Low nickel-grade ore is stored as waste rock at the mining site for future use, while the processed ore is stored in tailing ponds. The total nickel ore hoist has been about 14 Mt, which had an average Ni content of 0.60% (Teir *et al.*, 2006). If the hoisted ore has an average MgO content of 34 wt%, 5.3 Mt of CO<sub>2</sub> could be stored using the presently hoisted ore alone.

##### 4.3.3 Basalt

Basalt could also provide a calcium and magnesium-containing feedstock for mineral carbonation, because it is the most common igneous rock and is found widely distributed throughout the world. Crystalline basalt contains 7–10 wt% Ca, 5–6 wt% Mg, and 7–13 wt% Fe (Matter *et al.*, 2009). In a study by McGrail *et al.* (2006), the potential for *in situ* carbonation of flood basalts was estimated at 100 Gt of CO<sub>2</sub> in the eastern part of the U.S. alone. Since the bedrock on the Fennoscandian shield is very dense and not reactive, *in situ* carbonation is likely to not be a feasible option. However, the bedrock of Iceland is very young and 90% of it consists of reactive basalt.

In the ongoing project at Iceland (CarbFix) the possibility to inject CO<sub>2</sub> into aquifers in basaltic rock for *in situ* mineralization of CO<sub>2</sub> is evaluated (see also Chapters 4.2.4 and 5.2). After injection of CO<sub>2</sub> into deep aquifers in basaltic rocks, the CO<sub>2</sub> may react with calcium and magnesium cations in the aquifer to precipitate carbonate minerals:

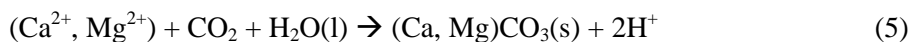

Since CO<sub>2</sub> is an acidic gas, the surrounding basalt rock will react with the released protons:



(Forsterite)



(Ca-plagioclase)

There has not yet been any assessment of the storage capacity for this method in Iceland.

#### 4.4 Summary

The capacities for storing CO<sub>2</sub> in geological formations are very unevenly distributed in the Nordic countries. The mature offshore aquifer storage capacity in Norway was estimated to 84.6 Gt CO<sub>2</sub>, with a maximum injection rate of 254 Mt/a. The mature onshore and offshore aquifer storage capacity in Denmark was estimated to 1.7 Gt CO<sub>2</sub>. The south-western and south-eastern sea areas of Sweden have also favourable geological formations, but significant exploration in this region is needed before storage estimates can be provided. In Finland, the bedrock is not suitable for geological storage of CO<sub>2</sub>. Although Finland, Sweden and Norway have significant, but not well quantified, resources of magnesium silicate rock suitable for carbonation, the large mining operations needed are likely to make it an unattractive option for CO<sub>2</sub> storage alone. In Iceland, the bedrock consists mostly of reactive basalt, which may be used for underground injection of CO<sub>2</sub>. However, the feasibility of this method is not yet known.

## **5. Overview of CCS projects within research, technology development and demonstration**

CCS as a climate mitigation option is a topic that attracts increasing interest in most industrialised countries. Since it was first realised by Statoil in 1996, intentionally to obviate the Norwegian CO<sub>2</sub> tax, the Statoil-operated Sleipner project has ever since been regarded a lighthouse project that is carefully looked at from most of the industrialised world. Today, numerous of pilots are popping up around the globe, and some firm planning for large-scale demonstrators is progressing. Still, a commercial CCS-based power plant in operation remains to be observed.

### **5.1 Current CCS operations**

A great number of large-scale CCS projects or pilots and research projects were planned and announced in Europe, America, Asia, Australia etc. However, so far only four fully-integrated CCS projects operate commercially on a global scale, whereof none is intended for large-scale power generation (a summary of these can be found in Appendix C1). Nevertheless, these projects are considered as breakthrough technology, and thereby contribute to the knowledge base needed for widespread CCS use.

Three of the projects; notably Sleipner, In Salah and Snøhvit are facilities that produce natural gas in which the CO<sub>2</sub> content of the gas stream exceeds a specific level. To achieve commercial-grade quality of the natural gas, CO<sub>2</sub> is stripped, collected and stored securely in geological formations deeply underground. The fourth project, Weyburn, makes use of compressed CO<sub>2</sub> that is captured from a coal-based synfuel plant (in USA) and piped to an oil field for en-

hanced oil recovery (EOR) in Canada. In total, these four plants store more than 5 million tonnes of CO<sub>2</sub> annually (Mt/a).

### 5.1.1 Sleipner

The Sleipner project started in 1996. It is operated by Statoil in the North Sea about 250 km off the Norwegian west coast, and is the first commercial-scale project in the world dedicated to geological CO<sub>2</sub> storage in a saline formation. As the natural gas extracted from the offshore Sleipner West Gas Field contains about 9% of CO<sub>2</sub> the gas must be stripped to a maximum content of 2.5% CO<sub>2</sub> in order to meet the required export specifications. Furthermore, in order to avoid a government-imposed carbon tax, Statoil built a special offshore platform to separate CO<sub>2</sub> from other gases. The CO<sub>2</sub> is injected into the Utsira saline formation some 800 meters below the seabed near (and above) the natural gas reservoir. The formation is estimated to have a capacity of about 600 billion tonnes of CO<sub>2</sub>, and it is expected that the aquifer may to continue to receive CO<sub>2</sub> from other sources long after the natural gas extraction at Sleipner has ended.

Associated with Sleipner, the Saline Aquifer CO<sub>2</sub> Storage (SACS) project was established to monitor and research the storage of CO<sub>2</sub>. From 1995, the IEA Greenhouse Gas R&D Programme has worked with Statoil to arrange the monitoring and research activities. Approximately 1 Mt CO<sub>2</sub> per year is removed from the produced natural gas stream and injected into the underground. Over the lifetime of the project, a total of 20 Mt CO<sub>2</sub> is expected to be stored. The saline formation into which the CO<sub>2</sub> is injected is brine-saturated unconsolidated sandstone about 800–1000 m below the sea floor. The formation also contains secondary thin shale layers, which influence the internal movement of injected CO<sub>2</sub>. The top of the formation is fairly flat on a regional scale, and the overlying primary seal is an extensive, thick, shale layer.

This project is being carried out in three consecutive phases: Phase-0) baseline data and evaluation, (completed in 1998), Phase-1) establishment of project status after three years of CO<sub>2</sub> injection<sup>11</sup>, Phase-2) data interpretation and model verification (since year 2000).

---

<sup>11</sup> I.e. description of reservoir geology, reservoir simulation, geochemistry, assessment of need and cost for monitoring wells and geophysical modelling.

The fate and transport of the CO<sub>2</sub> plume in the storage formation has been monitored successfully by seismic time-lapse surveys. The surveys also show that the caprock is an effective seal that prevents CO<sub>2</sub> migration out of the storage formation. Today, the footprint of the plume at Sleipner extends over an area of approximately 5 km<sup>2</sup>. Reservoir studies and simulations covering several thousand years suggest that CO<sub>2</sub> will eventually dissolve in the pore water, which will become heavier and sink, thus minimizing the potential for long-term leakage (Figure 5.1).

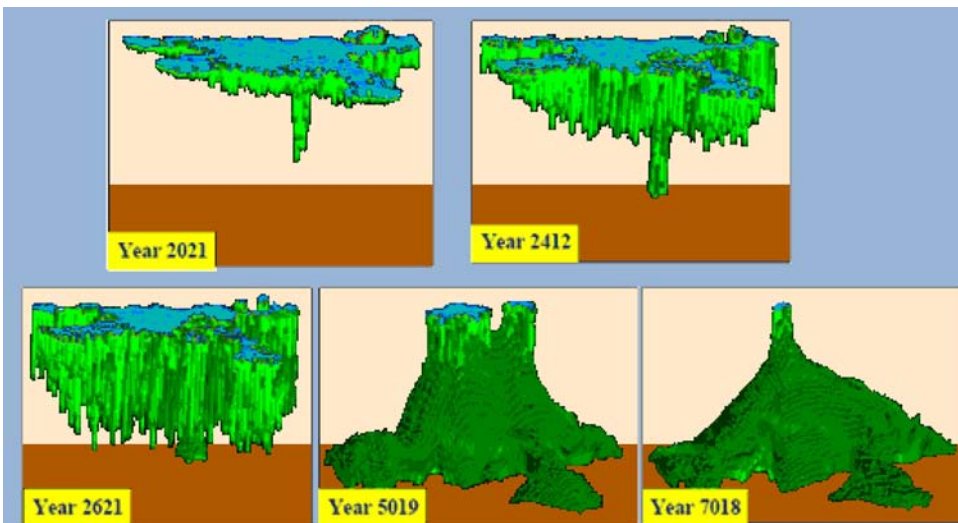

Figure 5.1. The geological trapping is characterised by three steps: 1) CO<sub>2</sub> will first coalesce and dissolve in rock pores at the top of the saline formation beneath a seal of cap rock. 2) It will then dissolve and diffuse into the underlying brine. This CO<sub>2</sub>-enriched brine (green) is denser than the brine and sinks as the CO<sub>2</sub> dissolves. 3) Over thousands of years the CO<sub>2</sub> will be dissolved near the bottom of the formation. This typical behaviour for CO<sub>2</sub> in a saline formation, may vary depending on geologic trapping mechanisms of formations. Legend: Blue: Un-dissolved CO<sub>2</sub>, Green: CO<sub>2</sub>-enriched brine (Source: SINTEF).

The Sleipner West facility comprises two main installations, the Sleipner B (SLB) wellhead platform on the field and the Sleipner T (SLT) treatment platform, adjacent to the Sleipner East facilities. SLT is linked physically to the Sleipner A platform by a bridge. Other major component parts of the development include a 12.5 kilometre flow line from SLB to SLT. The wellhead plat-

## 5. Overview of CCS projects within research, technology development and demonstration

form is remotely operated from the Sleipner A (SLA) control room via an umbilical line.

The carbon dioxide removal process used to remove CO<sub>2</sub> from the high pressure natural gas stream is based on amine scrubbing technology. The natural gas flows into the bottom and out through the top of two contacting towers. The flow direction of the solvent (MDEA and water) is counter-current of the natural gas flow, and as the solvent leaves at the bottom of the tower it will have absorbed the major bulk of the carbon dioxide. Subsequent stages then strip off the CO<sub>2</sub> in a desorber unit. The separation of the CO<sub>2</sub> from the amine solution is carried out using equipment installed in one of the SLT modules, these comprising of heat exchangers, pressure vessels, storage tanks, pumps and filters. The carbon dioxide module weighs ~8200 tonnes and stands 35 metres high; overall costs amount to over 350 M€

The other SLT module is used for gas treatment. Following removal of the CO<sub>2</sub>, the natural gas is transferred to SLA for export to continental Europe. The CO<sub>2</sub> is also transferred to SLA, for injection into the Utsira aquifer. A percentage of the natural gas produced is also reinjected into the Sleipner East reservoir in order to improve the condensate production.

Licensees for the Sleipner West field are Statoil (operator) with 49.5% (this includes 32.4% as the Norwegian government's direct financial interest), Esso Norge with 32.2%, Norsk Hydro with 8.9%, Total Fina Elf Exploration Norge with 9.4%.

What is rather unique with the Sleipner project is the high porosity and also the high permeability of the geological reservoir that make it possible to inject 1 Mt/a of CO<sub>2</sub> through only one well.

### 5.1.2 In Salah

In August 2004, Sonatrach, the Algerian national oil and gas company, with partners BP and Statoil, began injecting about 1 Mt/a of CO<sub>2</sub> into the Krechba geologic formation near their natural gas extraction site in the Sahara desert in Algeria. The Krechba formation lies 1800 meters below ground and is expected to receive 17 million tonnes of CO<sub>2</sub> over the life of the project.

The Krechba Field at In Salah produces natural gas containing up to 10% CO<sub>2</sub> from several geological reservoirs and delivers it to markets in Europe. In order to meet the commercial specification, the CO<sub>2</sub> is stripped off and captured using the Ethanol-Amino solvent. Like Sleipner, rather than venting the CO<sub>2</sub>, which is

the established practice on other operations of this kind, the CO<sub>2</sub> is compressed and injected it in deep-hole wells some 1 800 metres below the ground beneath the gas reservoir where the structure is filled with water. Around 1 Mt/a of CO<sub>2</sub> is injected into the reservoir.

The project consists of four production wells and three injection wells. Long-reach (up to 1.5 km) horizontal wells are used to inject CO<sub>2</sub> into the reservoir. The Krechba Field is a relatively simple anticline<sup>12</sup>. Carbon dioxide injection takes place down-dip from the gas/water contact in the gas-bearing reservoir. The injected CO<sub>2</sub> is expected to eventually migrate into the area of the current gas field after depletion of the gas zone. The field has been mapped with three-dimensional seismic and well data from the field. Deep faults have been mapped, but at shallower levels, the structure is unfaulted. The storage target in the reservoir interval therefore carries minimal structural uncertainty or risk. The top seal is a thick succession of mudstones up to 950 m thick.

A preliminary risk assessment of CO<sub>2</sub> storage integrity has been carried out and baseline data acquired. Processes that could result in CO<sub>2</sub> migration from the injection zone have been quantified and a monitoring programme is planned involving a range of technologies, including noble gas tracers, pressure surveys, tomography, gravity baseline studies, microbiological studies, four-dimensional seismic and geomechanical monitoring.

### 5.1.3 Snøhvit

Europe's first liquefied natural gas (LNG) plant near Hammerfest also captures CO<sub>2</sub> for storage. Statoil extracts natural gas and CO<sub>2</sub> (~5 vol%) from the off-shore Snøhvit gas field in the Barents Sea. The gas is produced entirely via sub-sea installations, and the gas mixture is first piped 160 kilometers to shore for processing at a 4.3 Mt/a LNG plant (celebrated as the northernmost town of the world). Separating the CO<sub>2</sub> is necessary to produce LNG and the Snøhvit project captures about 0.7 Mt/a of CO<sub>2</sub>. Starting in 2008, the captured CO<sub>2</sub> is piped back to the sea and injected in the Tubaasen sandstone formation 2600 meters underneath the seabed and below the geological formation from which natural gas is produced.

---

<sup>12</sup> i.e. an aquifer with a natural convex cap that keeps the CO<sub>2</sub> trapped.



In October 2001, Statoil and its partners filed a formal development plan for the Snøhvit Field, the first offshore gas field found in the Barents Sea and the point of supply for Europe's first LNG export project. Ultimately, the field will contain a total of 21 production wells, but only one single CO<sub>2</sub> injection well. All of the facilities associated with the operation of the production plant are beneath the surface of the sea, connected to the shore via a 160 km long pipeline. The Snøhvit facility is the first subsea development where all functions are controlled remotely from a land-based operation centre. A receiving station is built at Melkoya, near Hammerfest, where the LNG terminal is placed. This is responsible for removing CO<sub>2</sub> from the gas stream, which is then being piped back to the field for injection through the dedicated well.

The development work began in 2002 and the first LNG shipped to markets in Europe and USA was made in 2008. The development cost of the total project, including 4 LNG ships is reportedly in the order of 5.2 billion US\$. The Norwegian government has a 30% direct financial interest in the project and Statoil is the operator of Snøhvit on behalf of the project partners: Statoil (22.9% share); Petoro (Norwegian state direct interest); TotalFinaElf (18.4% share); Gaz de France (12% share); Norsk Hydro (10% share); Amerada Hess Norge (3.26%); RWE-DEA Norge (2.81%); Svenska Petroleum Exploration (1.24% share). Costs associated with the CO<sub>2</sub> pipeline and injection well are around 1 billion Norwegian kroner or ~125 M€

### 5.1.4 Weyburn

Since September 2000, about 2.3 million tonnes per year of CO<sub>2</sub> is captured at the Great Plains Synfuels Plant in the U.S. State of North Dakota, a coal gasification plant that produces synthetic natural gas and various chemicals. The CO<sub>2</sub> is transported by pipeline 330 km (costing 100 million US\$) across the international border into Saskatchewan, Canada, and injected into the Weyburn oilfield where it is used for enhanced oil recovery (EOR). The CO<sub>2</sub> has given the Weyburn field, discovered 50 years ago, a new life: 155 million gross barrels of incremental oil are slated to be recovered by 2035 and the field is projected to be able to store 30 million tonnes of CO<sub>2</sub> over 30 years. CO<sub>2</sub> injection began in October of 2005 at the adjacent Midale oilfield, and an additional 45–60 million barrels of oil are expected to be recovered during 30 years of continued operation. The Weyburn project is the first instance of cross-border transfer of CO<sub>2</sub> from the USA to Canada. Another key feature of the project is that the CO<sub>2</sub> re-

sults from the harnessing of fossil fuels. Thus, the Weyburn project represents a significant increase in the use of anthropogenic CO<sub>2</sub> in EOR projects in both the USA and Canada.

The Weyburn oil reservoir is a fractured carbonate, 20–27 m thick. The primary upper seal for the reservoir is an anhydrite zone (CaSO<sub>4</sub>). At the northern limit of the reservoir, the carbonate thins against a regional unconformity. The basal seal is also anhydrite, but is less consistent across the area of the reservoir. Thick, flat-lying shale above the unconformity forms a good regional barrier to leakage from the reservoir. In addition, several high-permeability formations containing saline groundwater would form good conduits for lateral migration of any CO<sub>2</sub> that might reach these zones, with rapid dissolution of the CO<sub>2</sub> in the formation fluids. The field has been designed with a combination of vertical and horizontal wells to optimize the sweep efficiency of the CO<sub>2</sub>. In all cases, production and injection strings are used within the wells to protect the integrity of the casing of the well.

Monitoring is extensive, with high-resolution seismic surveys and surface monitoring to determine any potential leakage. Surface monitoring includes sampling and analysis of potable groundwater, as well as soil gas sampling and analysis. To date, there has been no indication of CO<sub>2</sub> leakage to the surface and the near-surface environment.

### **5.2 Large-scale CCS projects under planning**

CCS has not yet been demonstrated in a commercial scale power plant. In order for CCS to be a viable option for reduction of CO<sub>2</sub> emissions in the near future, there is a need for demonstrating CCS technology at near full-scale plants. Over the past two years, governments have made significant commitments that will facilitate the launch of between 20 to 40 large-scale integrated CCS demonstration projects by 2020 (IEA 2010a). Several more CCS projects have been announced around the world, but many of these projects are in an early phase. Hence, the projects included here are focused on the most promising projects in terms of funding, commitments and timeline.

In addition to the operational Sleipner and Snøhvit projects, there are three additional near full-scale projects underway in the Nordic countries: the projects at Meri-Pori, Nordjyllandsværket, and Mongstad (Figure 5.2). The CarbFix project in Iceland aims to test injection of CO<sub>2</sub> captured from a geothermal power plant.

## 5. Overview of CCS projects within research, technology development and demonstration

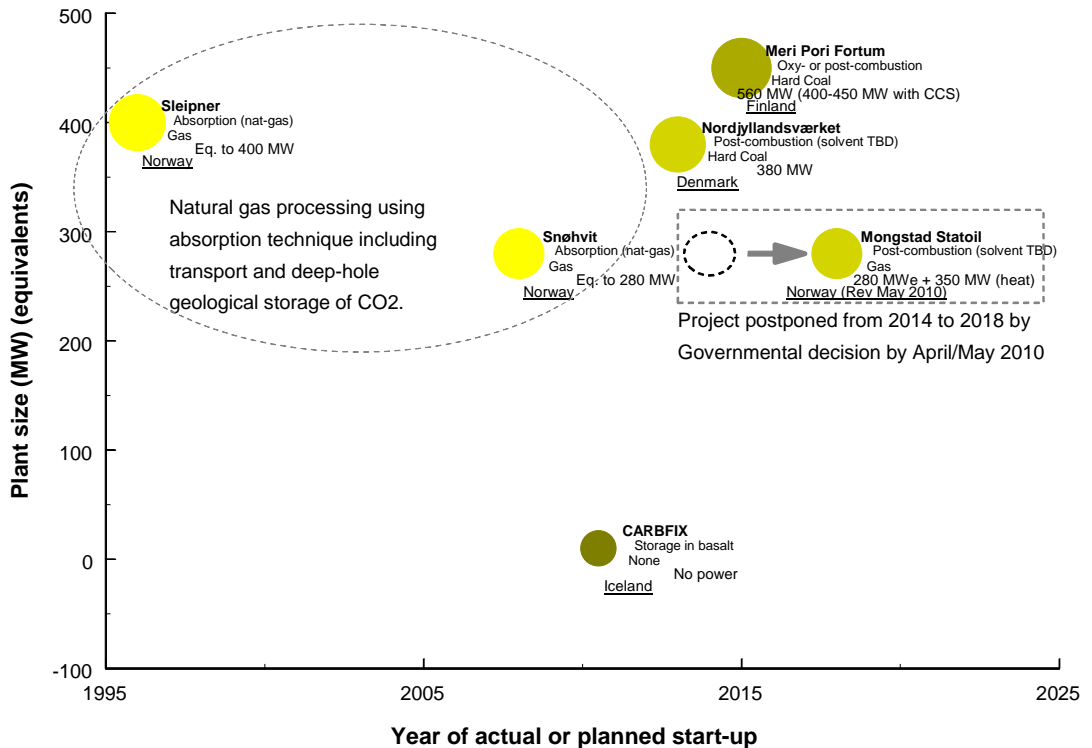

Figure 5.2. CCS demonstration projects in the Nordic countries.

### 5.2.1 Meri-Pori project

A CCS solution is currently being developed for the Meri-Pori power plant by Fortum and TVO (FINNCAP, 2010).<sup>\*</sup> The aim is to have the power plant retrofitted with post-combustion CCS technology by 2015 and to transport the CO<sub>2</sub> by ship tankers for storage in depleted oil and gas fields in the Danish part of the North Sea. According to the project's web page, the plant output is expected to decrease from 565 MW to 500 MW due to the CCS retrofit. The transportation distance to the North Sea is about 2 000 km and would require two tankers with a capacity of ~20 000 m<sup>3</sup> each. In addition, intermediate storage would be needed at the port of Pori. The project aims to become part of the European CCS demonstration programme (see Chapter 6.2.2). If the project is carried out, more than 1.2 Mt CO<sub>2</sub> would be captured and stored annually. The project is of high

<sup>\*</sup> At the time for publication of this report (27.10.2010), Fortum announced that the Meri-Pori CCS project has been abandoned.

## 5. Overview of CCS projects within research, technology development and demonstration

importance for demonstrating both the feasibility of CCS in Finland and the feasibility of a CCS plant located at a very large distance to the storage site.

### **5.2.2 Nordjyllandsværket**

The Swedish energy company Vattenfall plans to install a full-scale capture plant at the coal-fired power station at Nordjylland (Nordjyllandsværket) in Aalborg, Denmark (Vattenfall, 2010). The CO<sub>2</sub> will be transported 30 km with a pipeline and stored in a reservoir at a depth between one and two kilometres below the surface in northern Jutland. The feasibility of the storage site will be investigated by seismic survey and appraisal drilling.

### **5.2.3 Mongstad CCS project and the TCM**

The Mongstad refinery, located at the west coast of Norway, represents the largest single emission source in Norway. A full-scale CCS project linked with an on-site CHP plant has been planned for which the CO<sub>2</sub> will mainly be extracted from the flue gas of a combined heat and power (CHP) plant and from some other significant emission units at the refinery – especially a residual crude oil cracker (Statoil, 2010). The Mongstad CCS project was first planned to become operational in 2014. However, owing to claimed uncertainty regarding candidate CCS technologies combined with exceedingly high investment cost (around 25 bn NOK), the Norwegian Government (recently) decided to postpone the project by 4 years. The decision was communicated by Prime Minister Stoltenberg in his 1 May speech in 2010. In his explanation he emphasised the necessity of improving the technology. The immediate interpretation is that the Norwegian authorities are – in 2010 – considering CCS as still belonging to the incubation phase and CCS is thereby deemed too risky for large-scale demonstration at a commercially operated refinery. Hence, the investment decision for the Mongstad project is still pending.

#### **5.2.3.1 Mongstad TCM**

Despite the postponement of the full-scale CCS plant at Mongstad, a CCS test facility known as the Test Center of Mongstad (TCM) is being pursued by Statoil under a partnership agreement with associated industrial players, and in

which the Norwegian Governmental is the main sponsor. The TCM is due to become operational in 2011. It is designed to capture 100 kt/a CO<sub>2</sub>.

#### **5.2.4 CarbFix project**

In an ongoing project at Iceland (CarbFix) the possibility to inject CO<sub>2</sub> into aquifers in basaltic rock for in situ mineralization of CO<sub>2</sub> (see also Chapter 4.3.3). The project aims to start injecting CO<sub>2</sub> captured from the geothermal gases of the Hellisheidi geothermal power plant into basaltic rock formation nearby in October 2010.

#### **5.2.5 Kårstø project**

The Kårstø refinery represents the second largest single point source emission in Norway. The majority of the CO<sub>2</sub> emissions at Kårstø originate from the Naturkraft gas-fired power plant and from the Kårstø gas terminal. There are ongoing plans to lead all the gases to one joint carbon capture plant and transport the captured CO<sub>2</sub> with pipelines to a storage reservoir. The Norwegian Government had plans to implement carbon capture at the refinery for up to 85% of the emissions and according to the original timetable full scale carbon capture should have been in operation from 2009. However, the refinery has until recently not been operating fully, and consequently the Norwegian government has not prioritized plans for carbon capture at this site. Therefore, it is not included in Figure 5.2. Now, on the other hand, the refinery has operated non-stop for the last 18 months and is thus rapidly rising as a potential candidate for piloting CCS technologies (Aftenposten 2010; Offshore & Energy 2010).

### **5.3 Research and demonstration projects**

As can be seen from Appendix C3 research and demonstration projects are ramping up in Europe and elsewhere in the world (mainly in North America, Asia and Australia). The table also shows that the main avenues for CCS are widely addressed as research topics and for demonstration. Seemingly, there is a preference for post-combustion capture concepts in Europe. This could be interpreted as a response to the top-down processes that have been imposed within the European Union and its Member States on industrial players, under which a state of urgency has been communicated to make steps for large-scale CCS

## 5. Overview of CCS projects within research, technology development and demonstration

demonstration on a short term basis – also via a firm stimulus package. As already evidences (above); whereas post-combustion techniques are seen as the most mature approach for making safe steps towards large-scale CCS, significant research efforts are still required in order to bring the alternative techniques up to a similar level of maturity.

In North America, Asia and Australia efforts are seemingly placed more evenly on all CCS technologies at hand – perhaps with some preferences on oxy-fuel combustion techniques and pre-combustion decarbonisation techniques. Oxy-fuel combustion may perhaps be linked with the lower demand for process water of this concept over that of post combustion, as parts of these continents are seen as fairly dry areas.

In the outset, China had particular interest (mainly) in pre-combustion techniques, notably polygeneration schemes using coal-gasification for electricity generation and production of chemicals and synthetic fuels (IGCC). This was motivated by the issue of security of energy supply, as coal-to-liquid was seen as a means for China to reduce its dependency on imported oil. China has gradually shifted its interest to also include oxy-fuel combustion and even post-combustion techniques: Today China has one meso-scale test facility in Shanghai rated at 120 kt/a CO<sub>2</sub>, and two pilots (one rated at 3–5 kt/a CO<sub>2</sub> in Beijing operating since July 2008, and one at 10 kt/a CO<sub>2</sub> in Chongqing that went into operation in January 2010) all using post-combustion CO<sub>2</sub> capture techniques. The meso-scale test facility operates on a slip-stream from a USC-PC plant belonging to the Huaneng Group. It went into operations in December 2009. In Appendix C3 the facility is listed as having a capacity of 100 kt/a, but owing to recent improvements the unit has been upgraded to 120 kt/a CO<sub>2</sub>. Like the 3–5 kt/a plant the 120 kt/a does not only capture the CO<sub>2</sub>, it also cleans the CO<sub>2</sub> to food grade quality for sale to the Chinese beverage industry whereby it generates profit.

As a precursor to a large-scale CCS plant in Norway<sup>13</sup> a CCS test centre is being built at Mongstad (TCM) adjacent to its oil refinery north-west of Bergen. According to plan the TCM will become operational in 2011. This centre will receive flue gas from a residual catalytic cracker and a CHP plant in order to adjust to various CO<sub>2</sub> concentrations (from that of natural gas to the level of coal

---

<sup>13</sup> The large-scale Mongstad plant was initially scheduled to become fully integrated with CCS from 2014, but recently the Norwegian Government decided to postpone the implementation to 2018. This was first announced on 1 May 2010.

power plants). TCM will have a capacity of 100 kt/a CO<sub>2</sub>. Provisions are made to facilitate the testing of various post combustion concepts (amines, carbonates and chilled ammonia) at a range of CO<sub>2</sub> concentration levels.

The driving force behind the increased interest in oxy-fuel combustion and gasification techniques is the inherently higher development potential of these concepts, which offers (theoretically) an efficiency penalty lower than that of post-combustion CO<sub>2</sub> capture. This has been discussed in more detail above.

In the context of this report numerous projects are listed, however, according to quite different needs, purposes and size of consortia as well as funding resources. It may, thus, give rise to questioning what a *CCS research and demonstration project* as those listed in Appendix C2 means. As no firm criteria have been stated a mention could be given as follows:

- Most of these projects are seemingly set to address the CCS chain (or parts thereof)
  - some projects may be devoted to CO<sub>2</sub> capture (including pre-conditioning and transport of CO<sub>2</sub>)
  - some projects are just focused on storage (geology)
  - some projects may address other topics related to CCS (e.g. legal and societal issues, public awareness etc.).
- Most projects are quoted by plant size, which is a rather inconsistent parameter
  - one should keep in mind that in some projects the size is given as *thermal* (either input by fuel or output by steam production – not always evidenced), and just a few are reported as *electric* (output)
  - roughly, one could consider a test facility rated at 30 MW (thermal) as being equivalent to 10 MW (electric) owing to the conversion factor.
- Projects reported with a plant size around 1 MW should be considered belonging to lab-scale research.

## 5.4 Nordic CCS R&D projects and programmes

As listed in Appendix C4 the CCS activity within the Nordic countries is quite significant – even on a global scale. Focus is largely placed on the CCS chain (listed as value chain in the table), and research and development, and some few

projects include even demonstration. The budgeted resources of the listed projects range from 150 k€ to 81 M€. Hence, the considerable aspect ratio (1:540) suggests that the objectives, purposes and timelines of these projects vary quite significantly – from paper studies to profound science and long-term commitments. Interesting to observe, however, is the international participation in some of the projects and their proficient partnerships made up by significant players far beyond the Nordic countries.

### 5.5 European R&D projects

CCS was initiated as a research topic in the early 1990s as an integral part of natural gas production. In order to comply with the sales specification of the European infrastructure for natural gas, some CO<sub>2</sub> had to be removed from the Sleipner gas. Furthermore, Statoil asked for exemption from the Norwegian CO<sub>2</sub> tax that was introduced in 1991 provided the CO<sub>2</sub> could be safely disposed of in a deep-hole aquifer underneath the sea, which led to the celebrated Sleipner project (1996). Later the potential for reducing the emissions from the European power sector has been addressed via numerous integrated R&D projects. However, the current status is that significant incentives will be required in order to embark on CCS. As it stands today it is impossible for the power sector to make profit with CCS. The reason is that CCS roughly means 25% additional fuel and 50% higher cost of electricity (CoE). For this reason CCS is and remains a policy issue. Until policies and a regulatory framework have been established and sufficiently harmonised among leading nations CCS will probably not be enacted as a compulsory measure.

Meanwhile, research and development will go on aimed at enabling CCS techniques that are more efficient and less costly. Other carbon intensive processes are furthermore brought up as candidates for CCS – mainly in the stationary industry. It is expected that CCS-related R&D pertaining to the European power sector will shift focus from research and development (as hitherto) to technology demonstration via large-scale facilities in the future. But still significant investments in R&D will be necessary in other sectors, as indicated in the following sub-sections.



### 5.5.1 ULCOS

The EU FP6 project ULCOS (Ultra-Low CO<sub>2</sub> Steelmaking) has proved that CO<sub>2</sub> capture from steel plants has a larger reduction potential per unit than that of conventional coal power generation – and the avoidance cost will be significantly lower. Typically, the latter will be in the range of one third and the reduction potential per plant may be as high as 2–3 times of what is expected in conventional coal-power plants.

The basic fact is that the off-gas from a blast iron furnace today contains around 25% CO<sub>2</sub> whereas the flue gas exhausted from coal-fired power plants contains around 13% CO<sub>2</sub>. By changing the blast from air to oxygen the CO<sub>2</sub> content of the top gas from the blast furnace may be raised to 45%. This amended technology has been tested at semi-scale (2 t CO<sub>2</sub> per hour) and an industrial scale demo is under construction by ArcelorMittal (Indian owner) in Eisenhüttenstadt, Germany<sup>14</sup>.

A similar situation, meaning a lower capture cost deriving from higher CO<sub>2</sub> content in off gases, may be sought and found in other industries – especially in the cement making, as CO<sub>2</sub> is released not only by the fuel, but also from the calcination. The pulp and paper industry also employs processes that generate high CO<sub>2</sub> concentrations.

ULCOS is based on 48 European companies and organisations from 15 European countries. The project includes process engineering, economics of energy and foresight studies within industrial processes ranging from steelmaking to biomass production and geological storage of CO<sub>2</sub>. Efforts are focused on possible ways to reduce CO<sub>2</sub> emissions in steel production with as much as 50% from current practice using the best routes for steelmaking as reference.

---

<sup>14</sup> Communication with Tore A. Torp, Statoil, Norway.

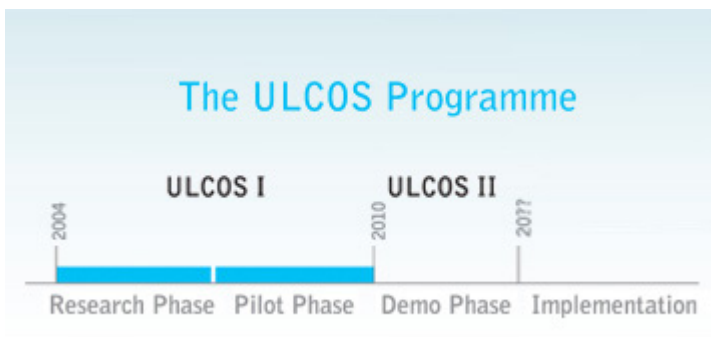

Figure 5.3. Timeline of the ULCOS programme, starting in 2004 and running to 2010 (recognized as ULCOS I, with a planned continuations up to 2017 (Phase II).

ULCOS forms the world’s largest endeavour in its kind. It comprises all major EU steel companies and leading energy and engineering partners, research institutes and universities with efforts that correspond to about 80 man-years each year. It is 40% co-funding by the European commission (EC FP6 and the Research Fund Coal Steel programme) (ULCOS, 2010).

Development of break-through technologies into mature industrial applications includes a level of risk that requires at least one scale up step for demonstration – recognised as ULCOS II (Figure 5.3).

The core members of ULCOS and the European Commission decided to launch ULCOS II in continuation of ULCOS I that will be completed in 2010. ULCOS II is planned to run from 2010 to 2015. It may result in solutions that may come into industrial use in some 15 to 20 years from now.

### 5.5.2 GeoCapacity

This project has been co-funded by the EU FP6. The main objective was to Assess the European Capacity for Geological Storage of CO<sub>2</sub>. The project included full assessments of a number hitherto not covered countries, and updates of previously covered territory. Priority was also given to further development of innovative methods for capacity assessment, economic modelling and site selection criteria.

### 5.5.3 MOVECBM

The objective of the EC MOVECBM project is to improve the understanding of CO<sub>2</sub> injection into coal seams and the migration of methane, thus ensuring long-term reliable and safe storage. In the MOVECBM project, modelling and laboratory work were based on parameters typical of a test site in Kaniów, Poland, previously investigated by the EC RECOPOL project. The former CO<sub>2</sub> injection well from the RECOPOL project was used to improve the understanding of CO<sub>2</sub> storage and ECBM through continuous monitoring of the composition of the gas to define the actual adsorption of CO<sub>2</sub> that was injected in the period August 2004 till June 2005.

In parallel to the field production test in Kaniów, a small scale combined injection and production experiment was carried out in the Velenje coal mine in Slovenia. In the coal mine, horizontal injection and production wells were used to investigate adsorption, desorption and migration processes for local coal conditions. The results from Velenje were expected to provide the missing information between the larger scale field experiment in Kaniów and the much smaller scale laboratory work.

### 5.5.4 Storage R&D projects

Unlike capture techniques that are deemed more generic processes that can be transferred from one project to another, storage is by far more site specific, and requires more pre-testing and time-consuming pre-qualification until they can be approved and opened for injection of CO<sub>2</sub>. During operation of these fields and even post closure the need for monitoring seems evident. In Table 5.1 some European test sites for storage are listed with the most relevant specificities thereof.

Table 5.1. European test sites for geological storage of CO<sub>2</sub>.

Site	Operating since	Location	Injection (kt/a)	Depth (m)	Operator
Tarnov	2008(?)	Onshore EOR, Poland	?	1500	CMI
K12-B	2006	Offshore EGR test, the Netherlands	20	3500	Gaz de France
Ketzin	2007	Onshore test, Germany	30	1000	GFZ/EU-CO <sub>2</sub> SINK

## **6. Economic and political frameworks for CCS**

The purpose of this chapter is to present a review of economic and political frameworks for CCS in Nordic countries. These frameworks determine the prospects of CCS since the value of CCS depends on political decisions, foremost on choice of climate policies, and since conditions for CCS are dependent on the wider context of energy and environmental policies. The review consists of four sections.

In the first section we review the status of targets, plans, policies and projections to reduce greenhouse gas (GHG) emissions and energy use, for example through fuel switching and more efficient energy use, for each of the Nordic countries. The review is divided into two time periods, 2010–2020 and 2020–2050.

In the second section we discuss the status of EU regulation on CCS and how this impacts Nordic countries.

In the third section the timeline for political processes with regard to implementation of CCS and involvement of industrial players is discussed. It turns out that at present limited information is available to assess what might be realistic timelines for CCS implementation. Partly this is due to a number of uncertainties related to future value and cost of CCS, and partly due to lagging political decision-making on CCS. Therefore, we end up with only presenting a few perspectives on what countries are prioritizing with regard to CCS policies and support.

In the fourth section we present a brief review of main CCS stakeholders in each Nordic country, divided into the categories public sector, industry, and others.

This review of policies, processes and stakeholders is meant as a background for assessing CCS deployment processes and strategies in other parts of this

report, particularly chapters 7 and 8, and as an underpinning of the recommendations we propose for the upcoming TRI research program on CCS.

## **6.1 Overview of policies on future use of fossil fuels and emission reduction commitments in the Nordic countries**

In this section we provide an overview of plans and projections for energy use in each of the Nordic countries until 2020 and 2050, with an emphasis on fossil fuels. We also include an overview of greenhouse gas emission reduction commitments or plans. The overview is divided into fossil fuel plans or targets till 2020 and 2050, and GHG emission reduction plans or targets till 2020 and 2050.

EU climate and energy policy has set a series of demanding targets to be met by 2020. These include a reduction in EU's greenhouse gas emissions of at least 20%, an increase of renewable energy sources to 20% of the total energy use, and a 20% reduction in primary energy use by improved energy efficiency. In addition to this, the share of renewable in transport fuels should be 10% by 2020. Due to the differences in economic developments and renewable resources of the Member States, each Member State has received individual target levels for renewable energy use, and for reducing emissions from the sector outside the EU ETS by 2020. As members of EU, these targets also apply to Finland, Sweden and Denmark. However, Norway and Iceland are also subjected to international political pressure to reduce greenhouse gas emissions.

### **6.1.1 Nordic energy statistics**

The energy systems vary among Nordic countries as shown in Figure 6.1 and Figure 6.2. Finland, Sweden and Denmark have a wide diversity of primary energy sources. In Finland and Sweden the primary energy sources include hydropower, nuclear power, oil, coal, biomass, peat and natural gas. The share of wood biomass is high because more than half of the wood used as raw material by pulp and paper mills ends up as on-site energy production. In Denmark, the primary energy sources are natural gas, coal, oil, biomass, and wind power. In Iceland and Norway renewable energy sources have the most significant role as a primary energy source because of the high proportion of hydropower, and also geothermal energy in Iceland.

6. Economic and political frameworks for CCS

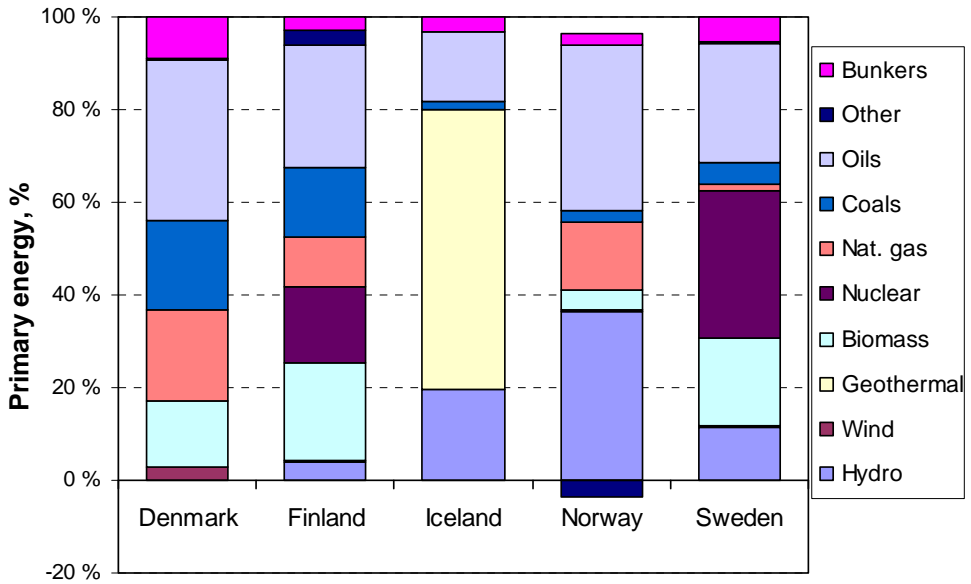

Figure 6.1. The shares of different primary energy sources in each Nordic country in 2008. The section “Other” represents mainly electricity import (+) or export (-). Data: IEA Statistics (IEA 2010b).

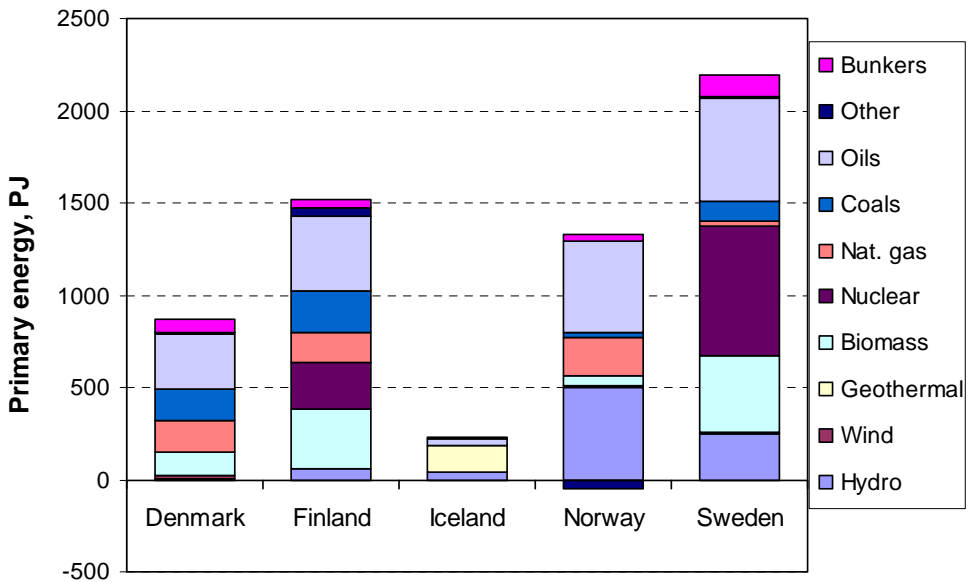

Figure 6.2. Primary energy use in each Nordic country in 2008. The section “Other” represents mainly electricity import (+) or export (-). Data: IEA Statistics (IEA 2010b).

The net electricity generation in the Nordic area has steadily increased from 344 TWh in 1990 to a record value of 414 TWh in 2008. Due to the economic recession, the net electricity generation dropped to a level of 383 TWh in 2009. As shown in the Figure 6.3, the electricity generation varies a lot in Norway and Sweden due to yearly variation in hydropower production. In 2005, the long industrial stoppage in the pulp and paper industry due to strike in Finland dropped the electricity demand clearly.

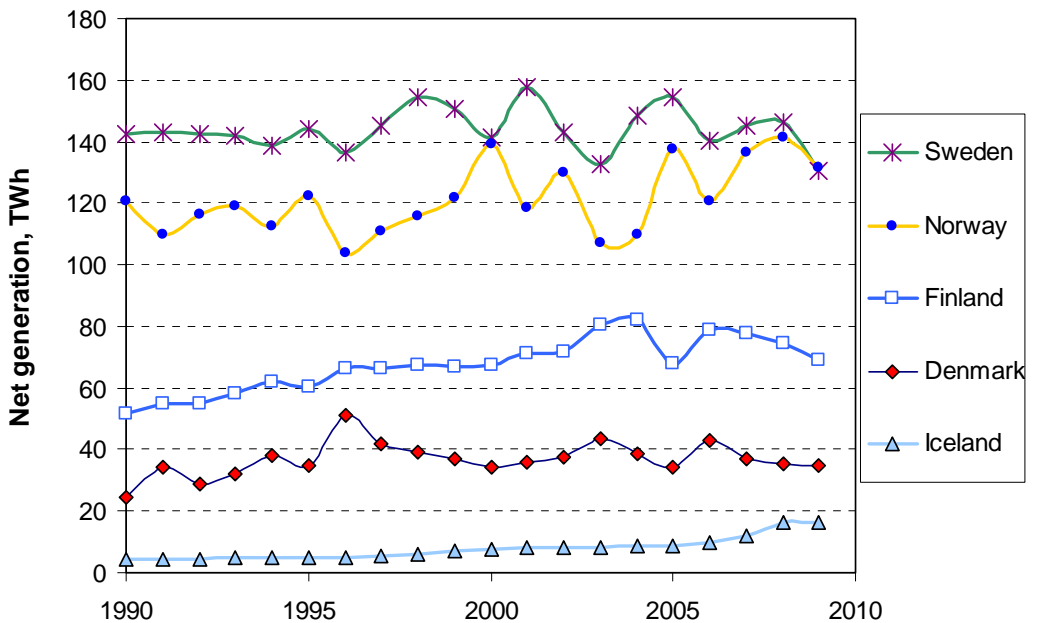

Figure 6.3. Net electricity generation in each Nordic country. Data: IEA Statistics.

### 6.1.2 Denmark

The Danish energy agreement from February 2008 sets the main agenda for energy policy until 2011, together with EU's targets until 2020. Denmark plans to reduce its gross energy use in 2020 by 4% relative to 2006. According to the renewable targets set by the EU, the renewable energy should increase from 17% in 2005 to be at least 30% of total energy use by 2020. These plans include more wind power (including offshore), and more biomass and waste for central heat-

ing and power generation. Thus, some coal to biomass fuel switching in power plants is included.

The government has set the target to reduce energy use by at least 4% before 2020 as compared to 2006 due to improved energy efficiency and energy savings. Final energy use is reduced by 1.5% in 2020, based on increased combined heat and power and other measures. Figure 6.4 shows expected gross energy use until 2025 by sector, where the energy sector levels out and slowly decreases. Energy use in industry and buildings also goes slowly down. Figure 6.5 shows the expansion of renewable energy and reduction of coal use.

The sectors not included in the EU ETS will reduce their GHG emissions by 20% in 2020 relative to 2005. Denmark introduced a carbon tax on energy products in 1992. The tax rate will be raised to DKK 150 per tonne of CO<sub>2</sub> (equivalent to 20 Euro per tonne of CO<sub>2</sub> at medio June 2010 exchange rate). Few additional policy instruments are planned, but there are some green tax shift planned and energy efficiency codes for buildings.

The long-term target is to become independent of fossil fuels.

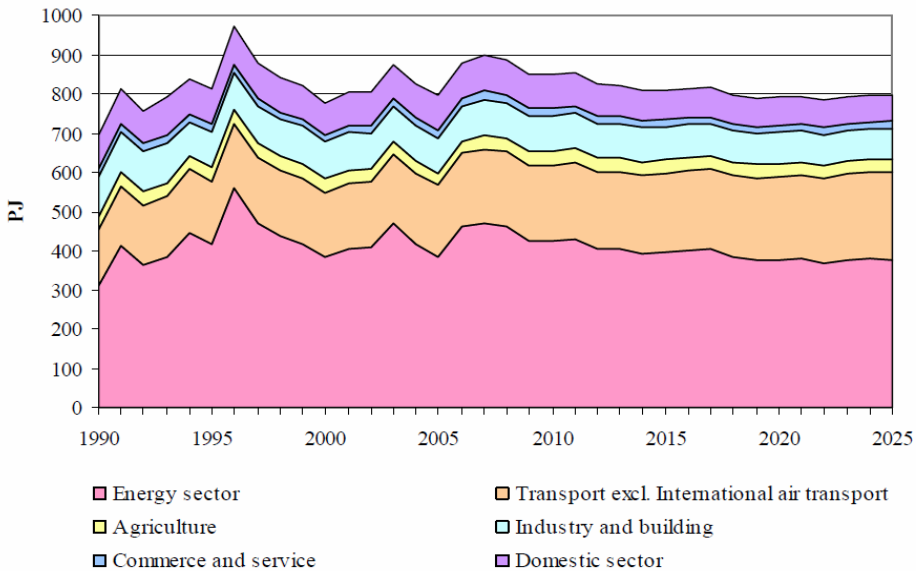

Figure 6.4. Expected gross energy use in Denmark until 2025 across sectors. Source: Ministry of Climate and Energy, Denmark (2009).



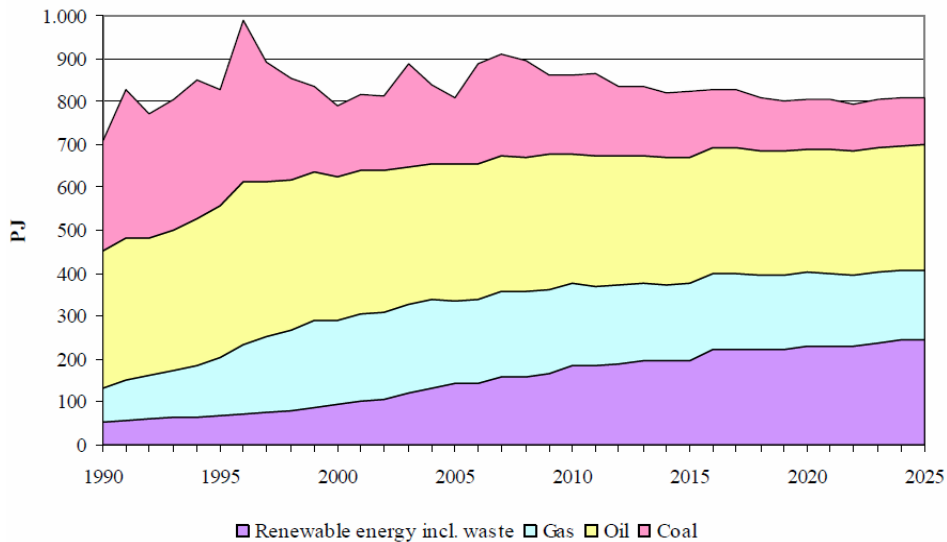

Figure 6.5. Expected gross energy use in Denmark until 2025 across energy sources. Source: Ministry of Climate and Energy, Denmark (2009).

### 6.1.3 Finland

The latest Finnish energy and climate strategy was accepted by the Government on 6th November 2008. This strategy covers climate and energy policy measures in great detail up to 2020, and in brief thereafter, up to 2050. In the Finnish strategy, two scenarios for 2020 have been developed: With Measures (WM) (the baseline scenario) and With Additional Measures (WAM). Only the WAM scenario meets Finland's post-Kyoto targets, so therefore we focus on this scenario. In 2009, the Ministry of Employment and Economy published new assessments on electricity and final energy demand by 2030, which takes into account the economic recession and the structural change of the Finnish forest industry. According to the EU target for 2020, renewable energy should increase to 38% of the final energy use (which is 9.5% above 2005 level). More use of wood-based fuels, bio fuels, wind power and heat pumps are the most important measures.

These policy targets are dependent on extensive financial aid. As an example a feed-in tariff for wind power, biogas, and small scale wood based electricity is planned. Renewable energy is supported by investment grants, taxation, subsidies and R&D funding. A central policy instrument for companies and municipi-

## 6. Economic and political frameworks for CCS

palities is a voluntary energy efficiency agreement scheme. These measures are assumed to save 37 TWh in final energy use by 2020.

Table 6.1 shows the development of primary energy use until 2020 in the WAM scenario. Coal-based fuels and natural gas are slowly reduced, whereas wood-based fuels and wind power shows the strongest growth. Table 6.2 indicates that in electricity generation the energy sources contributing to growth until 2020 are wind power and nuclear power. In February 2005 government gave a construction license for the fifth nuclear power plant unit, which is currently under construction. On 6 May 2010 the Council of State made two positive Decisions-in-Principle on nuclear power plant units, and on 1 July 2010 the Finnish Parliament ratified these decisions.

Table 6.1. Expected use of primary energy by sources in Finland 2005-2020 (Unit: TWh). Source: Ministry of Environment, Finland (2009).

	2005	2006	2007	2010	2015	2020
Transport fuels	46	47	48	46	44	39
Other oil	54	54	52	54	49	43
Coal-based fuels	38	62	53	57	52	48
Natural gas	41	46	41	46	43	39
Peat	19	26	28	24	20	20
Wood-based fuels	79	89	82	84	90	97
Nuclear power	68	67	68	67	106	106
Hydro power	14	11	14	13	14	14
Wind power	0	0	0	1	2	6
Others	5	6	9	10	8	17
Electricity import	17	11	13	11	7	0
<b>Total consumption</b>	<b>381</b>	<b>420</b>	<b>408</b>	<b>412</b>	<b>434</b>	<b>429</b>

Table 6.2. Expected supply of electricity in Finland 2005-2020 (Unit: TWh). Source: Ministry of Environment, Finland (2009).

	2005	2006	2007	2010	2015	2020
Hydro power	13.4	11.3	14.0	13.4	14.0	14.4
Wind power	0.2	0.1	0.2	0.7	1.5	6.0
CHP, industry	10.6	11.9	11.4	12.2	14.1	13.8
CHP, district heating	15.8	15.7	15.3	16.9	16.6	15.2
Nuclear power	22.4	22.0	22.5	22.0	34.9	34.9
Condensing power	5.3	17.6	14.3	16.7	12.4	14.6
Net imports	17.0	11.4	12.6	10.5	4.5	-1.0
<b>Total</b>	<b>84.7</b>	<b>90.0</b>	<b>90.4</b>	<b>92.4</b>	<b>98.0</b>	<b>98.1</b>

With a time horizon until 2050 energy use should be reduced by at least a further third as compared to 2020. This requires a significant increase of the renewable energy share with a focus on biomass, new nuclear power plants, phase-out of non-CCS fossil fuels use, and more use of natural gas. Energy intensity should be halved.

The GHG emissions forecast till 2020 is minus 23% compared to the situation without new measures. In line with the EU target Finland will reduce its GHG emissions by 20% from 1990 level, of which the reduction in EU ETS sectors is at 21%. In terms of non-EU ETS sectors GHG emissions will be reduced by 16% from 2005 level. Finland introduced a carbon tax in 1990. The current tax rate is at 18 Euro per tonne of CO<sub>2</sub> with some reductions for natural gas and energy intensive industries. However, new increased energy taxes have been considered, with higher tax rates for fossil fuels.

The aim is to reduce GHG emissions by at least 80% compared to 1990 as part of an international effort. Finland has developed four scenarios for GHG emissions until 2050: “Efficiency revolution”, “Sustainable daily mile”, “Self-sufficient”, and “Technology is the key”. Relevant measures are more energy-efficient buildings, electric cars/hybrid cars, higher share of renewable energy, and also CCS.

### 6.1.4 Sweden

Sweden’s target, set by the EU, is to increase the use of renewable energy from 44% in 2007 to 50% of total energy in 2020. Energy use by 2020 is to be made 20% more efficient than total energy use per unit of GDP in 2008. In the transport sector 10% should be renewable energy by 2020.

Sweden’s plans for 2050 involve more biomass for power production. The nuclear phase-out decision was cancelled by the Swedish parliament in June 2010. However, only replacement of existing reactors on existing sites will be allowed.<sup>15</sup> Transportation should become fossil-free by 2030. The planned capacity for possible wind energy expansion is 30 TWh (of which 10 TWh is offshore).

By 2020 GHG emissions should be 40% below 1990 emissions. Emissions outside the EU ETS sectors should be reduced by 17% compared to 2005. Two-

---

<sup>15</sup> Confer <http://www.regeringen.se/sb/d/2447>.

thirds of these reductions will be undertaken domestically and one-third through investments in the other EU countries or through flexible mechanisms such as the Clean Development Mechanism (CDM).

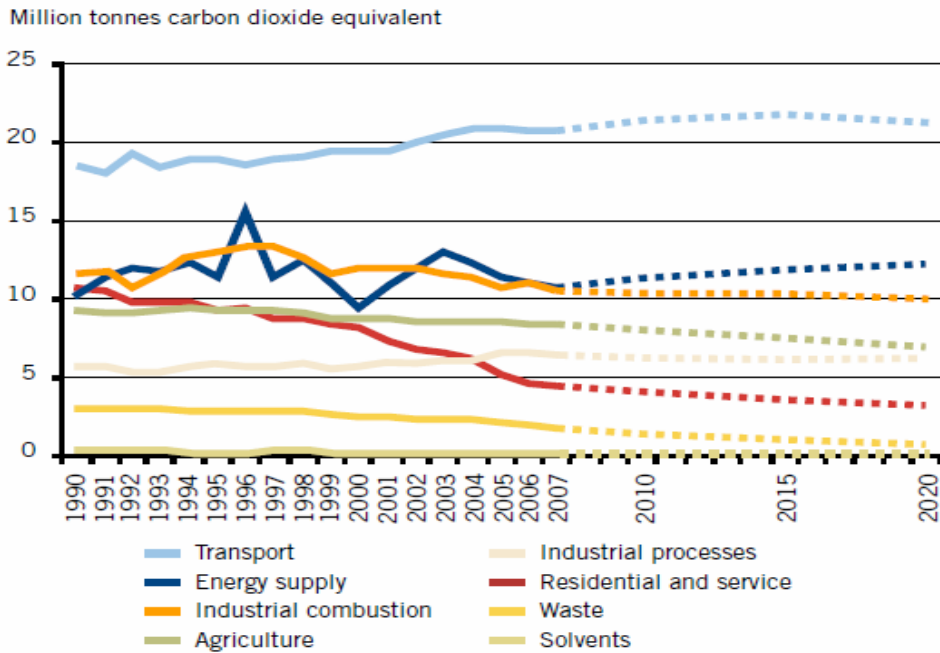

Figure 6.6. Historical and projected GHG emissions by sector. Source: Ministry of the Environment, Sweden (2009).

The main general policy instruments are energy and carbon dioxide taxes, emissions trading and green electricity certificates. The carbon tax was introduced in 1991. In 2009 the tax rate was at SEK 1050 per tonne of CO<sub>2</sub>, equivalent to 99 € per tonne of CO<sub>2</sub> at average 2009 exchange rate. In the electricity sector the green certificate system has been operated since 2003, aiming at increasing the production of electricity from renewable energy sources<sup>16</sup>. The green certificate system will continue at least until 2035. Furthermore, the Swedish and Norwegian governments have agreed on a common green certificate market from 2012. There are also other special incentives for wind and solar

<sup>16</sup> Certificate entitled production is electricity from wind energy, solar energy, wave energy, geothermal energy, biomass (according to specific regulation), some hydropower and peat in combined heat and power.

power are to be used, and ‘smart metering’ and energy audits for large consumers are planned. In industry there are specific programs for energy efficiency. Figure 6.6 shows projected GHG emissions by sectors until 2020. The emissions from the energy supply is expected to remain roughly at same level as the last couple of decades, but with some growth between 2010 and 2020, whereas the emissions from the other sectors are expected to go down.

Sweden’s long-term target is to act internationally with other countries to limit global temperature rise to 2 °C by 2100. The long-term vision is to have the net GHG emissions go down to zero by 2050.

### 6.1.5 Norway

The target of the national agency Enova SF is to reach 40 TWh in new renewable energy or energy savings by 2020.

The “Klimakur 2020” project was initiated by the Norwegian government in 2008 with mandate to elaborate on mitigation options and policy measures, and evaluate whether existing measures are sufficient to meet Norway’s 2020 climate targets. A main result from the project is the construction of a marginal abatement cost curve at national level. Marginal cost reaches 1000 NOK per tonne of CO<sub>2</sub> at about 8 Mt accumulated emission reduction, after which the marginal costs continues upwards reaching 2000 NOK per tonne at about 20 Mt reduction.

Norway’s target is to reduce global GHG emissions by the equivalent of 30% of Norway’s 1990 emissions by 2020. This target is lifted to 40% if this can contribute to an ambitious global climate agreement. According to a decision by the parliament, 2/3 of this reduction is to be carried out domestically. The main policy instruments are the carbon tax (which was introduced in 1991) and an emissions trading system linked to EU ETS. There are also agreements to reduce emissions in the processing industry. Furthermore, the Swedish and Norwegian governments have agreed on a common electricity certificate market from 2012.

The general ambition is to act internationally with other countries to limit global temperature rise to 2 °C by 2100. With respect to 2050 the target is carbon neutrality, which is specified as a reduction of global emissions by the equivalent of 100% of Norway’s emissions. If an ambitious global climate agreement is reached this target is to be met already by 2030.

### 6.1.6 Iceland

In Iceland industrial processes in energy-intensive industries were responsible for 36% of total CO<sub>2</sub> emissions in 2007. Renewable energy sources, hydro power and geothermal energy dominate at 80% of the total primary energy supply. Geothermal energy has increased over time and accounted by 2008 for about 60% of primary energy use. The plan is to develop more geothermal energy. The use of geothermal energy speeds up the release of CO<sub>2</sub> and other gases to the atmosphere. These emissions are estimated to be about 40% of a modern conventional gas-fired power station (without CCS).<sup>17</sup>

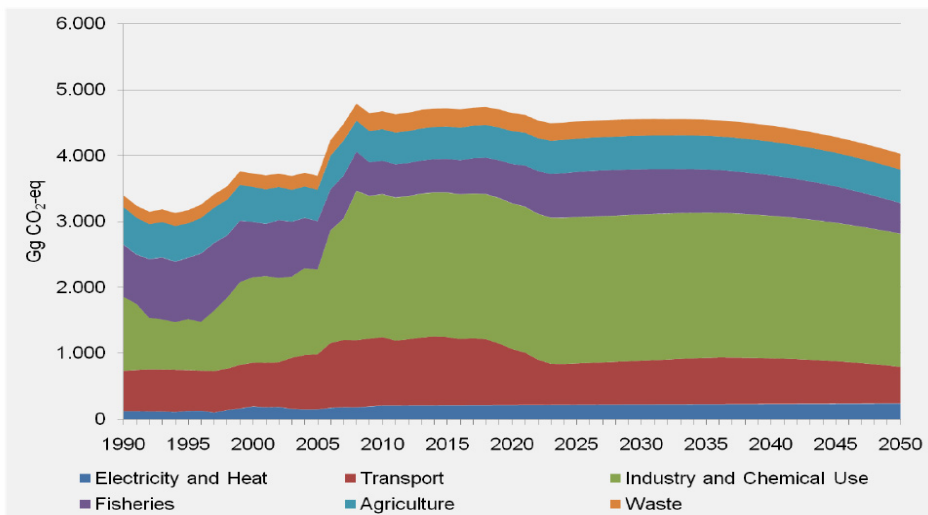

Figure 6.7. A forecast of GHG emissions by sector from Iceland. Source: Ministry for the Environment, Iceland (2009).

In terms of 2050 Iceland plans to develop more geothermal energy and hydro-power. The process technology in aluminium smelters can be improved to reduce GHG emissions, and there is a future potential for hydrogen as fuel for ships and cars.

Iceland in a joint effort with EU aims to reduce GHG emissions by 30% compared to 1990, given a new robust international climate agreement. Iceland in-

<sup>17</sup> Hetland, J. (2003), Geothermal power, HySociety project, memo.

roduced a carbon tax recently. Non-ferrous metal industry will be linked to EU ETS from 2013.

With a time horizon until 2050 Iceland plans to reduce GHG emissions by 50-75% below 1990 level. Figure 6.7 shows that the largest GHG emission growth is expected to come from industry and chemical use, whereas electricity and heat are much smaller and relative constant.

### 6.1.7 Summary

Table 6.3 provides a summary of national plans and policies to reduce emissions of greenhouse gases in Nordic countries until 2020, as well as in the longer term (until 2050).

Table 6.3. Overview of greenhouse gas emission reduction plans, projections and policies until 2020 and 2050 in Nordic countries.

Country	2010–2020	2020–2050
Denmark	<ul style="list-style-type: none"> <li>• Reduce gross energy use by 4%</li> <li>• Renewable energy 30% of total energy (wind power, biomass, waste)</li> <li>• EU ETS</li> <li>• Carbon tax</li> <li>• Energy efficiency codes for buildings</li> </ul>	<ul style="list-style-type: none"> <li>• Independence of fossil fuels</li> </ul>
Finland	<ul style="list-style-type: none"> <li>• Reduce final energy use by 11% compared to BAU</li> <li>• Renewable energy reach 38% of final energy use (wind power, biomass, heat pumps)</li> <li>• Increase nuclear power</li> <li>• GHG emissions reduced by 23% compared to BAU</li> <li>• EU ETS</li> <li>• Carbon tax</li> <li>• Feed-in tariff for wind power, biogas, and small-scale electricity production from wood</li> </ul>	<ul style="list-style-type: none"> <li>• Reduce energy use by at least 1/3 compared to 2020</li> <li>• Reduce GHG emissions by at least 80% compared to 1990 as part of an international effort</li> </ul>

## 6. Economic and political frameworks for CCS

Sweden	<ul style="list-style-type: none"> <li>• GHG emissions reduced by 40% (from 1990)</li> <li>• Increase renewable energy share to 50%</li> <li>• Wind energy growth up to 30 TWh</li> <li>• Energy use to become 20% more efficient</li> <li>• EU ETS</li> <li>• Carbon tax</li> <li>• Electricity certificates</li> </ul>	<ul style="list-style-type: none"> <li>• Net GHG emissions should go to zero</li> <li>• More biomass for power production</li> <li>• Transportation become fossil free</li> </ul>
Norway	<ul style="list-style-type: none"> <li>• Reduce global GHG emissions equivalent to 30% (or possibly 40%) of Norway's 1990 emissions</li> <li>• New renewable energy and energy savings reach 40 TWh</li> <li>• Carbon tax</li> <li>• National ETS linked to EU ETS</li> </ul>	<ul style="list-style-type: none"> <li>• Carbon neutrality; reduction of global emissions equivalent to 100% of Norway's emissions</li> </ul>
Iceland	<ul style="list-style-type: none"> <li>• Develop more geothermal energy</li> <li>• Carbon tax</li> <li>• National ETS linked to EU ETS</li> </ul>	<ul style="list-style-type: none"> <li>• Reduce GHG emissions by 50-75% below 1990 level</li> <li>• More geothermal energy and hydropower</li> <li>• Reduce GHG emissions through improved aluminium smelter processes</li> </ul>

## 6.2 Status of EU regulation on CCS and impacts on the Nordic countries

This section gives a brief outline on current European-level regulations and policies with respect to CCS, and impacts on the Nordic countries.

### 6.2.1 Regulation and crediting of storage activities

The European Union's CO<sub>2</sub> storage directive (2009/31/EC) prescribes procedures for how storage projects should be assessed and validated, and ensures that emissions reductions from CCS projects may be credited under the EU ETS (EC, 2009).



According to the directive, stored CO<sub>2</sub> is treated as avoided CO<sub>2</sub> emissions. In case of leakage, the corresponding amount of emission trading allowances has to be surrendered. Storage is allowed within the territory of the Member States, in their exclusive economic zones and on their continental shelves. Storage elsewhere or in the ocean column is prohibited. The Member States retain the right to determine which storage sites may be selected, if any. The Member States also issue storage permits and decide the explorational needs for the storage sites, as well as ensure that the storage site operator sufficiently monitors and reports the progress of the injection.

The directive contains also several requirements for the operator. The CO<sub>2</sub> stream should consist mainly of CO<sub>2</sub> and simultaneous disposal of other gaseous wastes with the CO<sub>2</sub> stream is not allowed. The directive does not specify the allowed levels of impurities in the CO<sub>2</sub>. After closure of the site, the responsibility of the storage site can, after proving that the injected CO<sub>2</sub> remains safely stored, be transferred from the operator to the Member State authorities.

The directive is now being implemented in the Member States, which are scheduled to give their first report on implementation by June 2011. The Directive applies not only to the Nordic EU members Denmark, Finland and Sweden, but also to Norway and Iceland through the European Economic Area (EEA) agreement. This means that future CCS activity in the Nordic region will be regulated by a European-level regime for approval and validation of storage projects. It also means that CO<sub>2</sub> storage in the Nordic countries may be credited as avoided emissions in reporting to the European emissions trading scheme.

### **6.2.2 EU funding for demonstration projects**

The European Union has committed to the establishment of a network of up to 12 large-scale CCS demonstration plants in the EU by 2015. As part of its financial crisis recovery program, the EU set aside 1 billion € specifically for CCS demonstration projects. Six projects have been selected for such support. None of them are located in the Nordic region. However, one of the projects – demonstration of oxy-fuel combustion capture at the Jämschwalde power plant in Germany – is owned by Vattenfall. Also, VTT and Foster Wheeler Energy participate in the development work of the CFB oxy-fuel combustion capture for the Spanish demonstration project in Compostilla.

In a separate funding initiative, proceeds from auctioning 300 million allowances in the EU Emissions Trading Scheme Phase II (2008–2012) will be ear-

marked for large-scale demonstration projects of CCS and renewable energy. With a permit price of 15 €/per ton, that would mean 4.5 billion €. Much of this may be allocated to the projects already receiving recovery program funding, because these projects are not yet fully funded.

It is interesting to note that the EU gives priority to demonstrating capture from power generation fired with coal or lignite. None of the currently selected projects plan to capture CO<sub>2</sub> from the combustion of natural gas or biomass, both of which are important sources in the Nordic countries. Policy makers in the Nordic countries may wish to pay special attention to ensuring that sufficient technology research, development and demonstration activities are carried out in these areas as well.

### 6.2.3 State aid rules

The EU also encourages Member State funding of CCS demonstration projects, but the Commission suggests that such funding will be limited to the initial demonstration phase.<sup>18</sup> In the longer term, national subsidies for CCS will be difficult under EU competition law (for Member States and EEA countries).

### 6.2.4 Infrastructure planning

One area where we have observed little activity at the European level so far is with respect to planning for possible infrastructure development in the near future. This is an area where strengthened efforts may be useful.

Current scenarios for deployment suggest a very rapid buildup of a major CCS industry in Europe and elsewhere. For example, a recent scenario from the IEA suggested capture of 26 million tons of CO<sub>2</sub> annually from power plants in OECD Europe by 2020 and as much as 680 million tons by 2050.<sup>19</sup> The figure for 2020 appears very optimistic. The European Union envisages capture and storage of perhaps seven million tons in 2020 and up to 160 million tons of CO<sub>2</sub> by 2030. The latter figure would contribute significantly to meeting the Union's commitments under an international regime aiming at global temperature stabilization (possibly in the order of 15% of required reductions).<sup>20</sup>

---

<sup>18</sup> Confer SEC (2008) 55, page 6.

<sup>19</sup> IEA 2009a. IEA Technology Roadmap. Carbon capture and storage

<sup>20</sup> Directive 2009/31/EC

One limiting factor for large-scale deployment over one or two decades is the project lead time for capture facility, transportation infrastructure and storage site development. It is likely that public acceptance concerns will limit the availability of onshore storage sites close to major concentrations of industry on the continent of Europe. This may make the offshore storage capacity under the North Sea very attractive in a European perspective. However, utilization of this potential would require a very large pipeline infrastructure. Such projects are often controversial and require coordination of diverse stakeholders and as a consequence it takes time from the first initiatives to realization. Early planning for possible infrastructure solutions may therefore be important.

### **6.3 Timeline for political processes with regards to the implementation of CCS and involvement of industrial players**

Due to many uncertainties related to future conditions for CCS and lagging decisions in Nordic countries on CCS policies it is difficult to assess realistic timelines for implementation of CCS. We are therefore left with presenting some perspectives on what countries have stated as CCS targets and are prioritizing with regard to CCS policies and support.

#### **6.3.1 Denmark**

CCS policies are less developed in Denmark. CCS is not mentioned in government's climate policy brief with a time perspective till 2020.

#### **6.3.2 Finland**

Currently, there is no clear policy for CCS in Finland. Decision making has been concerned more on nuclear and renewables. However, CCS is noticed as one important technology by 2050 with 80% emission reduction target.

#### **6.3.3 Iceland**

Iceland has no geological formations for storage of CO<sub>2</sub>, and the closest known formations in the North Sea are located 2500 km away. The option to store CO<sub>2</sub>

## 6. Economic and political frameworks for CCS

in underground basalt formations is currently investigated, but far from a mature storage option yet. This means that CCS in an Icelandic setting is challenging.

### 6.3.4 Norway

The Norwegian government is funding a number of ambitious CCS technology development programs. These are R&D programs, a technology test center at Mongstad, the full-scale CO<sub>2</sub>-separation and storage operation associated with the Snøhvit gas field in Finnmark, and planning a full-scale CCS plant linked to a gas-fired power station at Mongstad. The Mongstad CCS plant was recently postponed until 2018.

### 6.3.5 Sweden

The CCS discussion in Sweden is at an early stage. In June 2010 the Government's working group on the environment and climate stated that CCS is desirable for large manufacturing industry emission sources such as steel and cement.<sup>21</sup> The representative from the leading government party stated that they aim to prohibit new coal fired power stations unless these are prepared for retrofitting with CCS (Svenska Dagbladet 2010). After the Swedish parliament election in September 2010 some of the unsettled issues related to Swedish policies on CCS could be clarified.

EU's CCS directive is now being implemented in Swedish law. Sweden aims for linking one of the EU-funded CCS pilot plants to Swedish primary industries. Possible candidates for CCS application are industrial facilities producing steel, cement, as well as paper and pulp.

## 6.4 Identification of stakeholders

In Table 6.4 we present major stakeholders related to CCS in each Nordic country, divided into public sector, industry and others. Under the public sector category the ministries most concerned with CCS are listed. In terms of the industry category we have included the industrial sectors responsible for the largest point

---

<sup>21</sup> The Swedish Government coalition is led by Moderaterna, which is a liberal conservative party.

emission sources in each Nordic country, confer Appendices A1 to A5 to this report. In the 'Others' category we have listed the main environmental NGOs.

In addition to sectors and organizations, there is a geographical dimension to stakeholders. Local or regional clusters of stakeholders actively promoting CCS deployment exist. Confer also the overview of regional emission source clusters contained in section 8.2, which covers all Nordic countries.

### **6.5 Summary**

The documentation of economic and political conditions for CCS in the Nordic countries presented in this chapter show that these countries more or less aim at decarbonizing their economies in the longer term. This would require a high tag on GHG emissions and possibly an important role for CCS. With a 2020 time horizon most Nordic countries have quantified targets to reduce GHG emissions, mainly through increased deployment of renewable energy and energy efficiency measures supported by GHG pricing with the help of emissions trading and carbon taxes.

EU regulation on CCS will impact the conditions for CCS in the Nordic region. The most important linkages are through the CCS directive on CO<sub>2</sub> storage and through funding of CCS demonstration projects. So far there has been little activity at European level regarding to planning of CCS infrastructure development.

A number of uncertain factors determining the future scope for CCS and political decision-making at an early stage in Nordic countries mean that it is difficult to make an assessment of what the realistic timelines for deployment of CCS are.

In all Nordic countries main stakeholders such as ministries, companies responsible for the largest point emission sources and environmental NGOs can be identified. Technology developers and the service sector could also be added to this list. There are many examples of regional clusters of stakeholders in each of the Nordic countries, typically induced by the localization of large point emission sources.

## 6. Economic and political frameworks for CCS

Table 6.4. Major CCS stakeholders in Nordic countries.

Country	Public sector	Industry	Others
Denmark	<ul style="list-style-type: none"> <li>• Ministry of the Environment</li> <li>• Ministry of Climate and Energy</li> <li>• Ministry of Economic and Business Affairs</li> <li>• Danish Energy Agency</li> </ul>	<ul style="list-style-type: none"> <li>• Power and heat</li> <li>• Cement production</li> </ul>	<ul style="list-style-type: none"> <li>• Danish Nature Protection Association</li> </ul>
Finland	<ul style="list-style-type: none"> <li>• Ministry of the Environment</li> <li>• Ministry of Employment and the Economy</li> </ul>	<ul style="list-style-type: none"> <li>• Steel production</li> <li>• Oil refining</li> <li>• Power and heat</li> <li>• Pulp and paper</li> <li>• Cement production</li> <li>• Fuel production</li> </ul>	<ul style="list-style-type: none"> <li>• The Finnish Association for Nature Conservation</li> </ul>
Iceland	<ul style="list-style-type: none"> <li>• Ministry for the Environment</li> <li>• Ministry of Industry, Energy and Tourism</li> </ul>	<ul style="list-style-type: none"> <li>• Ferrosilicon and aluminium production</li> </ul>	<ul style="list-style-type: none"> <li>• Icelandic Environment Association</li> </ul>
Norway	<ul style="list-style-type: none"> <li>• Ministry of Oil and Energy</li> <li>• Ministry of Environment</li> <li>• Ministry of Trade and Industry</li> <li>• Climate and Pollution Agency</li> </ul>	<ul style="list-style-type: none"> <li>• Oil and gas refineries</li> <li>• Offshore installations</li> <li>• Cement production</li> </ul>	<ul style="list-style-type: none"> <li>• Bellona</li> <li>• Zero</li> <li>• Norges Naturvernforbundet</li> <li>• Natur og ungdom</li> <li>• Greenpeace</li> <li>• Norges Fiskarlag</li> </ul>
Sweden	<ul style="list-style-type: none"> <li>• Ministry of Enterprise, Energy and Communications</li> <li>• Ministry of Environment, Energy and Climate</li> <li>• Swedish Environmental Protection Agency</li> <li>• Swedish Energy Agency</li> </ul>	<ul style="list-style-type: none"> <li>• Steel production</li> <li>• Pulp and paper</li> <li>• Power and heat</li> </ul>	<ul style="list-style-type: none"> <li>• Swedish Society for Nature Conservation</li> <li>• WWF Sweden</li> <li>• Swedish Friends of the Earth</li> <li>• Greenpeace</li> </ul>

## 7. Public awareness and acceptance for CCS

The public opinion of carbon capture and storage (CCS) has repeatedly been emphasized as an essential factor to realize large-scale development and deployment of the technology. There are several reasons to recognize the public mind as a powerful force which needs to be understood properly, not least by those who engage in the development of CCS. Its significance can be supported by at least three arguments:

1. Public acceptance has been pointed out as critical to realize CCS by several experts in the field, most notably by the Intergovernmental Panel on Climate Change (IPCC, 2005).
2. A number of practical experiences have revealed that CCS projects run the risk of being delayed, paused or even cancelled due to public opposition.
3. Other projects that share similar characteristics have experienced difficulties due to public opposition.

These insights have prompted an increasing demand recent years for CCS research relating to the public. The challenges associated with understanding the public mind are, however, more complex than one might think at first glance. As this review will point out, public opinion is formed by a huge number of individuals which are influenced by a range of social factors as well as each other. Nevertheless, there is a need for studies that increases our understanding of the critical ingredients in this matter: awareness, knowledge, perceptions, attitudes, opinions; as well as communication and dialogue. In comparison to the knowledge acquired through research on e.g. the technical development of CCS, we know surprisingly little about public opinion which has the potential to make or

break costly investments. Indeed, the public can assume a role in which it does not develop to an oppositional force, but rather turns into a constructive one.

This chapter outlines a research overview of public opinion towards CCS as well as a number of communication aspects. Building on recent reports, peer-reviewed articles and empirical observations of recent real-life experiences, it shows critical features in our knowledge to date and illuminates promising research areas for further development. The chapter directs particular attention to the Nordic countries, despite the limited amount of public opinion studies carried out in the region to date.

### **7.1 Overview of public opinion research**

Studies applying a social science perspective on CCS are still few within the CCS field as a whole. Within the social scientific branch of CCS, however, public opinion is a recognized factor in several large, interdisciplinary, ongoing projects (e.g. CATO-2 in the Netherlands). Contributions on the public opinion on CCS began to appear regularly in reports and scientific journals a few years into the 2000's, but documented studies from the Nordic countries remain scarce. This developing research area has only begun to analyze the way the public is currently dealt with and examine lessons that can be learnt from previous research in adjacent fields. As CCS is expected to enter a critical phase over the next couple of decades, we should not postpone the efforts needed to push the boundaries of current knowledge and examine ways to make useful applications of research findings.

A clear message from studies performed so far is that few people are familiar with CCS. Studies repeatedly confirm that a minority of the general public have heard of CCS. This observation has been made across countries and regions as well as gender and age. The percentage of the population that has heard of the technology varies between 4–22% in the studies underpinning this overview. An exception is a recent poll from Norway, the country which has been described as a CCS world pioneer (Meadowcroft & Langhelle 2009), in which 63% of the respondents claimed that had heard of CCS either a little bit or quite a bit (Pietzner et al 2010). Wide-spread unfamiliarity of CCS is risky for those who are keen to advance its implementation. Awareness, or a more sophisticated knowledge, about a topic is likely to reduce the risk of latter opposition. Understanding how familiar people are with the technology is an essential point of



departure, both for designing research and taking action for example through designing communication material.

Despite the fact that CCS can be described as fairly anonymous, there is an eagerness to find out what people think about CCS. A range of studies have therefore been concerned with quantitative measurements of current attitudes and opinions, akin to research of public opinion in other empirical fields. Studies of current support to CCS, however, do not point in one clear direction. Previous research has identified neutral (de Best-Waldhober et al. 2009; Fishedick et al. 2009) or moderate (Gough 2008; Huijts et al. 2007) attitudes towards CCS in the Netherlands and the United Kingdom. Public attitudes have been studied both with and without providing information material to the respondents beforehand, showing that more information on CCS can lead to both an increased (Tokushige et al. 2007) and decreased (de Best-Waldhober et al. 2009) level of support. Such observations implicate that the results have been influenced by the information *per se*. Few studies have attempted to predict public opinion on CCS. Although such predictions would be of large interest, such studies are difficult to perform, since public opinion depends on a vast amount of co-existing factors of social character.

Research which has taken on the task to measure support for CCS highlights an important caveat; self-assessed knowledge and attitudes at the individual level needs to be tested and verified. A study by Curry et al. (2004) has revealed that even people who claim they have heard of CCS fail to respond to what environmental problem it seeks to address. Yet, despite knowledge gaps, a significant amount of respondents tend to have an opinion about CCS. This phenomenon has been described as pseudo-opinions (Daamen et al. 2006). It strengthens the proposition that the role of information in studies of public opinion is both influential and tricky to handle, since it seems to have significant impacts on the results. In the event of a fundamental breakthrough in common knowledge about CCS, this bias would consequently be less serious. Other researchers have correlated attitudes towards CCS with gender, age or demographic factors (e.g. Gough 2008). Men are in general more accepting towards new technology than women (Miller et al. 2007) and recent studies have indeed identified a difference in the way men and women perceive CCS (Pietzner et al 2010).

A clear distinction should be made between individual opinion and public opinion. Studies examining current awareness and support for CCS among individuals run the risk of treating opinion as something which is triggered in isolation from other people. However, public opinion refers to the aggregate of peo-

## 7. Public awareness and acceptance for CCS

ples' attitudes which takes shape in social interaction among many individuals. Quantitative surveys are useful to achieve a snapshot of current attitudes among a large number of people but have limited value in understanding how opinions are formed and what underpins them. The perspective that public opinion takes shape at collective level has been highlighted in previous CCS research (Huijts et al. 2007), but has not been satisfactorily studied to date. To make internal relationships among individuals researchable, however, it is necessary to dramatically reduce and demarcate the population under study. A possible way to grasp a population in this regard would be to align with another influential argument in the literature on public opinion which prescribes that we should only direct attention to the people who engage in the debate of an issue at a given point in time. This perspective disregards from laypeople with little or no interest in the issue and focuses on those who are more likely to influence the debate.

Some scholars have attempted to identify differences in attitudes depending on how CCS is designed and implemented. For example, Shackley et al. (2007) and Huijts et al. (2007) have showed that people are more supportive to CCS at a global level, or when CCS is discussed in principle, but less supportive if it were to be implemented nearby. Such attitudes can be linked to the well-known not-in-my-backyard-phenomena, where people are positive to a certain issue in general as long as it is done elsewhere. Other researchers have suggested studying attitudes towards CCS in relation to its different components, i.e. capture, transport and storage (Vajjhala & Fischbeck, 2007). Another study has focused on identifying differences in public opinion and preference between six different CCS technologies (de Best-Waldhober & Daamen, 2006). New angles of public opinion obviously bear potential to add to existing knowledge, but it is also important to carefully consider the added value of detailed surveys.

It has been argued that attitudes towards CCS are linked to attitudes about climate change in general. For example, IPCC (2005) suggested that people are more likely to be positive towards CCS if they at the same time agree that climate change is a serious problem and that it is important to mitigate global warming. According to this logic, it is useful to analyze attitudes towards CCS in light of (often pre-existing studies of) attitudes towards climate change in the population. If we assume a connection between attitudes towards CCS and climate change, a glimpse at recently measured attitudes towards climate change in the Nordic countries is a useful starting point. Results from two recent polls on public attitudes to global warming are presented in Table 7.1 below. The second column, "Awareness of climate change", has been drawn from a global poll on

climate change opinions (Pelham, 2009). The Nordic countries stand out in the sense that general awareness about climate change is very high. 90–98% of the respondents claimed they know “something” or “a great deal” about global warming, which exceeds the global average of 61% by far. In fact, four of the five Nordic countries are among the top 12 countries in the world in this category. This picture can be complemented with the results from the Eurobarometer’s special report on European climate change attitudes (European Commission, 2009). The third column presents the responses to the question “How serious a problem do you think climate change is at the moment?” Here, the Nordic EU member countries came out close to the average citizen in the EU-27. 86–91% of the respondents in Denmark, Finland and Sweden described climate change as a fairly or very serious problem, compared to the EU-27 average of 87%. The perceived importance to mitigate climate change, another factor mentioned by IPCC (2005), was not covered in either of these surveys. Taken together, the wide-spread awareness and perceived seriousness of climate change in the Nordic countries suggests promising prospects for public acceptance. However, there is still a need for cautiousness in making such correlations, since several other factors may play a decisive role in determining evolving CCS attitudes. In addition, attitudes towards environmental issues usually change in cycles, so the timing component could be factor to consider when designing for example communication material (cf. next section “Communication and dialogue”).

Table 7.1. Public attitudes to global warming in the Nordic countries.

<b>Country</b>	<b>Awareness of climate change (%)</b>	<b>Climate change as a fairly or very serious problem (%)</b>
Denmark	90	86
Finland	98	91
Iceland	95	N/A
Norway	97	N/A
Sweden	96	88
EU-27	N/A	87
Global	61	N/A

Another way to grasp the current status, and to some extent trends, in public opinions is to examine stakeholders' standpoints towards CCS and analyze news reporting in the media. Organizations which engage in the debate are well equipped to influence an abundance of individuals, and ultimately, the public mind. It is therefore useful to identify influential stakeholders to CCS (see Chapter 6) and stay updated on their positions and the statements they make as it may offer a hint about a forthcoming debate, at least in the near future. Stakeholders should always be identified in the specific context in which they operate. However, environmental non-governmental organizations can be expected to take an active role in debating emerging and topical environmental issues such as CCS. The media is another source which reveals societal trends and it plays an influential role in disseminating ideas and framings of the technology.

Hence, studying positions and common arguments among stakeholders can give an idea about what arguments that might feature a public debate. In the CCS community, these arguments are well-known. Arguments in favor of CCS revolve around the urgent need to use all means available to fight global warming. Examples of arguments against CCS are the possible risks related to storage of CO<sub>2</sub>; an increased dependence on fossil fuels ("carbon-lock-in"); the large financial investments compared to other means of reducing greenhouse gas emissions; and the risk that investments on CCS are made at the expense of development of e.g. renewable energy. Several environmental non-governmental organizations have proclaimed their conditional support to CCS, i.e. they support the technology if certain criteria are met. Other types of arguments are more locally grounded, such as fear of decreasing value of property, which was emphasized during local protests in Barendrecht, the Netherlands (Voosen, 2010).

Several methodologies have been used to study factors relating to the public opinion of CCS and they have revealed serious methodological challenges. Most studies to date have used surveys, interviews or focus groups to collect primary empirical data. The majority has used a quantitative approach (predominantly surveys) to examine current knowledge, awareness and attitudes towards CCS (e.g. Ashworth et al. 2010, de Best-Waldhober et al. 2009, Curry et al. 2004; Daamen et al. 2006, Reiner 2008, Shackley et al. 2007). These studies are often similar to polls, and the idea is to get a snapshot of current opinion. The survey methodology has been questioned in the study of public opinion of CCS since it measures something which is largely unknown to the general public (Malone et al. 2010), but it has an obvious edge in allowing for a large sample at one point in time. In the study of public opinion, the question of whether and to what ex-

tent polls in themselves might influence public opinion is intensively debated (Sonck & Loosveldt 2010). Interviews, on the other hand, allow for in-depth conversation but a downside is that it assumes at least some previous knowledge about the topic. Interviews may be more feasible when targeting experts or when the topic has become sufficiently well-known to the public. A small number of studies have used focus groups (e.g. Oltra et al. 2010), in which a group of people engage in a discussion under supervision. Moreover, it is remarkable that a large amount of research have been linked to explicit goals of increasing acceptance towards CCS among the public – an objective which can be perceived as non-neutral and potentially controversial.

Most studies on public opinion so far have used a national perspective and studied public opinion within particular countries. They have been performed in countries where CCS is either mainly hypothetical or a real term opinion, such as Australia, Spain, the U.S. and France, just to name a few. Several social, political and economic CCS issues are indeed country-specific (Meadowcroft & Langhelle 2009) and in this sense, the nation-state is an interesting context to direct attention to. However, it is naturally important to take into consideration possible national factors, should one generalize the results to other countries. In contrast, other studies have pointed out site-specific local community context as particularly interesting for further research (Oltra et al., 2010). In selecting a site-specific area, the storage site is particularly interesting against the fact that storage of CO<sub>2</sub> has proved to be an activity sparking public opposition.

Being a relatively new field, there is significant potential to contribute to the CCS literature by examining acquired knowledge within the field of e.g. public opinion research. Public opinion is in itself a research field, which within academia dates back to the writings of Adam Smith in the 18<sup>th</sup> century. Although his work seem distant to contemporary CCS research, scholars interested in increasing our understanding of public opinion should re-discover the insights on public opinion which have developed during the last decades, alongside increasing interest in society of monitoring markets and the broader environment. To understand the Nordic conditions, we should build on existing knowledge about the Nordic countries' social, political and economic situation and tradition.

## **7.2 Communication and dialogue**

The communication of CCS provides an opportunity to not only inform the public about ongoing plans but it also contributes to evolving perceptions among the

## 7. Public awareness and acceptance for CCS

general public and an increased understanding of the issue. Therefore, it is something of a paradox that research about the communication of CCS is so rare to date (Reiner, 2008). Compared to the studies of public opinion and support of CCS, it is difficult to find research focusing on the communication of CCS. Nevertheless, the issue has proved important. In cases where public opposition towards CCS has become an issue, it has been commonly explained as due to “a failure of outreach”. The practical difficulties to successfully communicate a technology to the general public illuminate the need for applicable research in this area.

A fundamental issue concerns the decision between adopting a proactive or a reactive communication approach. In a proactive approach, stakeholders and the public are informed and engaged at an early stage, whereas a reactive approach is more passive in character. Ashworth et al. (2010) recommend communicating CCS in a proactive manner. Oltra et al. (2010), however, discuss pros and cons of both approaches. For example, a proactive strategy might alarm the public and create perceptions which do not correspond to estimated risks. A reactive approach, on the other hand, is sensitive to criticism. There is also a democratic aspect of informing the public about activities which may, however unlikely it is, affect them directly or indirectly. However, it is not sufficient to begin early with communicating a CCS project. In the words of a leader of a local protest group towards CO<sub>2</sub> storage in Barendrecht: "Communicating a bad plan ahead of time doesn't make it a good plan" (Voosen, 2010).

In the spirit of proactive engagement, a large number of researchers have developed seven principles for efficient community engagement (World Resources Institute, forthcoming). These guidelines are summarized as follows:

- prepare communities before engaging
- determine what level of engagement is needed
- integrate community engagement into each phase of the project cycle
- include traditionally excluded stakeholders
- gain free, prior and informed consent
- resolve community grievances through dialogue
- promote participatory monitoring by local communities.

Another issue to consider is if, or to what extent, the public should be engaged in the discussions. An increasing number of actors argue that communication is not synonymous to one-way propaganda and that there is a democratic aspect in allowing the public to formulate an opinion of their own. Citizen involvement in

political and societal processes is a tendency in society which also has been analyzed in the academic literature, e.g. as “deliberative democracy” (e.g. Bessette, 1980). When communicating the risks associated with CCS, it is useful to recognize that risks should not only be analyzed in light of statistical determinations of the probability for a certain event. Risk can also be influenced by human perceptions and these are constructed in a social context where they are subject to interpretation. Overall, the CCS field has a lot to learn from communication studies of various kinds, such as risk communication, environmental communication and technological communication. For example, the observation that men and women have different attitudes towards CCS (Pietzner *et al.*, 2010) raises issues of gender-diversified communication strategies.

There are by now a number of recent experiences, among corporations and policymakers, of communicating CCS. These activities have been preceded by efforts well thought through and carried out at Nordic markets as well as internationally. There are unrealized opportunities to summarize and synthesize the knowledge and experiences earned throughout the process, from the strategic considerations to the actual information material used. Important lessons can be drawn both from projects which have faced public resistance and those which did not. Collecting and analyzing material on how this issue has been tackled by companies and policymakers with different degrees of success, would be useful to increase our understanding of what constitutes an efficient and smooth communication of CCS. This would in turn constitute a valuable basis to spread best practice in the field. There may also be important lessons to be drawn from comparable cases, such as underground storage of natural gas and final storage of nuclear waste, which seem to be commonly associated with storage of CCS by the general public. This type of research can be supported by Reiner (2008) suggestion to test different information material and study how people respond to various types of information material.

## **8. Future role for CCS in the Nordic countries**

In this chapter the possible role of CCS in the Nordic countries has been assessed, partly by energy system modelling and partly by studying regional options for CCS application to existing facilities. The costs for applying CCS to power plants have also briefly been assessed. Using the results from these assessments, a rough overview for possible CCS deployment in the Nordic countries has been made.

### **8.1 Scenario studies evaluating future CCS adaptation**

It is evident that there is considerable uncertainty around the development of future energy systems in the Nordic countries, especially after the year 2020. Undoubtedly, the biggest uncertainty concerns the future climate and energy policies on global, EU and national levels, which will have an impact on new investments on energy conversion, infrastructures, and end use applications. On the other hand, not only CCS, but also several other new low-emission energy technologies are still in the development phase, and the analysis is therefore based around hypothetical scenarios for their long-term technical and economical developments. The basis for the scenario calculations is the existing technical energy system and its calculatory phasing out in each Nordic country. In the scenarios, the existing industrial structure is used with some increase in their production of goods, materials, etc. It is evident, that there is no guarantee that the future industrial structure looks the same in the coming decades. This will have a great impact on energy demand and greenhouse gas emissions. Below some of the major uncertainties in the scenario studies evaluating future CCS adaptation are listed:



- National and sectoral emission reduction targets in each Nordic country, in the EU, and globally for CO<sub>2</sub> and other greenhouse gases
- Development of the EU ETS and a global emissions trading system (i.e. inclusion of CCS and bio-CCS with “negative emissions”) as well as EU’s and national energy and climate policies (taxes, subsidies, regulations, etc.)
- Development of CCS and other low-emission energy technologies (costs, efficiencies, life times, availabilities, etc.)
- Future point sources of CO<sub>2</sub> emissions in energy and industrial sectors.
- Cost-effective CO<sub>2</sub> storage potential
- Future market prices of commodities and emission allowances.

### 8.1.1 Modelling approach

The role of CCS in the Nordic energy systems has been studied with a bottom-up energy system model called Nordic TIMES, which has been created by VTT. The Nordic TIMES model includes a large database describing the entire global energy system, divided into 17 regions. In the model, Europe comprises the regions Western Europe, Eastern Europe and the four Nordic countries Denmark, Finland, Norway and Sweden. Iceland is included in the Western Europe region due to model limitations for the number of single regions. For each region, the database includes a wide variety of technology options for energy conversion, distribution and end-user devices in all sectors of the economy. The Nordic TIMES model used in this study includes models of all anthropogenic emissions and control technologies for carbon dioxide (CO<sub>2</sub>), methane (CH<sub>4</sub>), nitrous oxide (N<sub>2</sub>O), and the F-gases of the Kyoto protocol. CO<sub>2</sub> control technologies include carbon capture and storage (CCS), and also different forestation options. Carbon capture may be integrated in:

- Both fossil fuel and solid biomass-fired energy conversion plants,
- Industrial processes, like pulp, steel, cement, liquid fuel or hydrogen production

In total, the technological database of the model includes about 1500 different existing and new technology options for each region. Each technology is characterized by a number of techno-economic parameters.

## 8. Future role for CCS in the Nordic countries

The prevailing energy and environmental taxes in the Nordic countries have been included in the model, as well as the subsidies and other supporting systems on renewable energy. In addition, some other aspects of the existing policies have been imposed as constraints in the model, for example, the minimum deployment of wind power in the Nordic countries.

### 8.1.2 Scenario descriptions

Data for the reference year 2005 for each country and region has been taken from the IEA statistics (IEA 2009b). The database for the existing energy systems has been created and improved within several EU projects (see e.g. the EU RES Project<sup>22</sup>) in the IEA ETSAP collaboration (see e.g. the Energy Technology Systems Analysis Program from the Energy Technology Network<sup>23</sup>) and in the Nordic Energy Perspectives (NEP), Phase 1 & 2 projects (see e.g. Nordic Energy Perspectives<sup>24</sup>).

In this report, the development of the Nordic energy systems and the possible role of CCS in the Nordic countries (excluding Iceland) have been studied with two scenarios. In the baseline scenario, existing energy and climate policies are assumed (i.e. “business as usual”). In the climate policy scenarios, allowance prices are set as inputs (i.e. exogenous parameters) to the scenario calculations and they are set in the model to increase gradually from 20 €/tonne in 2010 to 30, 50, 70 or 90 €/t CO<sub>2</sub> in 2040. Emission trading includes all GHGs, thereby simulating cost-effective allocation of emission reductions between sectors. The detailed scenario descriptions can be found in the final reports as well as in the subreports of the Nordic Energy Perspectives -project. In this context, only the main conclusions have been drawn giving some possible pathways for the CCS deployment by the year 2050.

### 8.1.3 Scenarios for the future CCS adaptation

In the Nordic TIMES model the CO<sub>2</sub> transport has been modelled using different trade links for CO<sub>2</sub>. It is assumed that not only Nordic countries but also other European countries may transport their CO<sub>2</sub> to the North Sea in case that the

---

<sup>22</sup> <http://www.res2020.eu>

<sup>23</sup> <http://www.etsap.org>

<sup>24</sup> <http://www.nordicenergyperspectives.org>

model finds it to be a cost efficient mitigation option for those areas. The cost of CO<sub>2</sub> transport and storage is dependent on transport distance, transport type (on-shore or offshore pipeline, or ship), transport volume, and type of geological formation (aquifer, oil field, gas field, or coal bed). The data for the assumed available CO<sub>2</sub> storage capacities in Norway as well as in the Western and Eastern European countries is taken from the GeoCapacity project (Figure 8.1).

Figure 8.2 shows the reduction of greenhouse gases in the Nordic countries with different allowance prices. It can be seen that reduction of CO<sub>2</sub> emissions appears to be the most cost efficient GHG reduction method compared to the reduction of the other GHGs. The maximum GHG reduction level compared to the base year is nearby 80%, which is inline with EU's long term climate targets and close to the long term targets of each Nordic country.

Figure 8.3 and Figure 8.4 show the scenario results for the development of primary energy use and electricity production in the Nordic region. From the figure it is evident that even with the highest assumed emission allowance price levels the fossil fuels still might cover approximately 30% of the total primary energy use. On the other hand, the total net electricity supply is mainly based on renewables and nuclear, like the present situation.

The role of CCS in each Nordic country in the above mitigation scenarios is shown in Figure 8.5 and Figure 8.6. The scenario runs have been done both excluding and including the option for bio-CCS (i.e. extended or existing policies for emission counting and trading). It is clearly seen that bio-CCS would radically increase the theoretical CCS potential, especially in Finland and Sweden, which have large forest industry sectors and a high potential to use biomass for energy conversion.

## 8. Future role for CCS in the Nordic countries

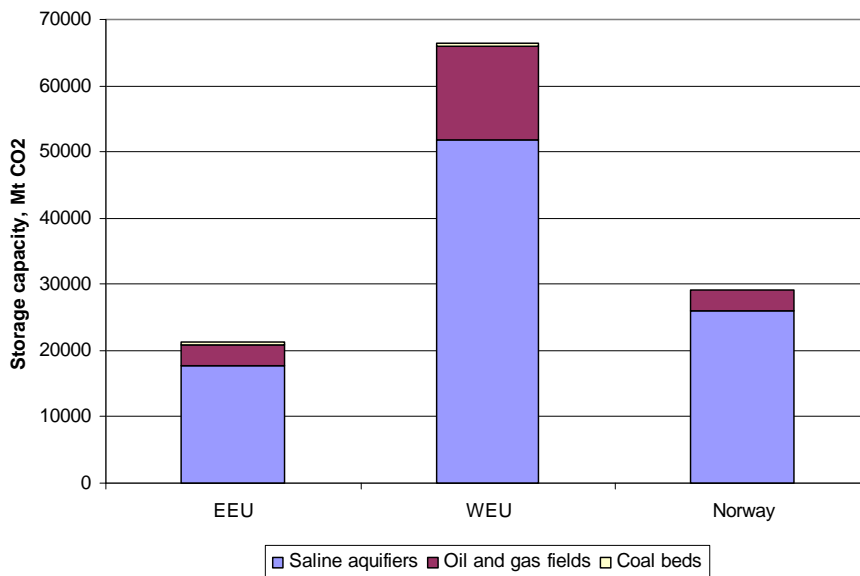

Figure 8.1. Assumed CO<sub>2</sub> storage capacities for Eastern Europe (EEU), Western Europe (WEU), and Norway (data: EU GeoCapacity project).

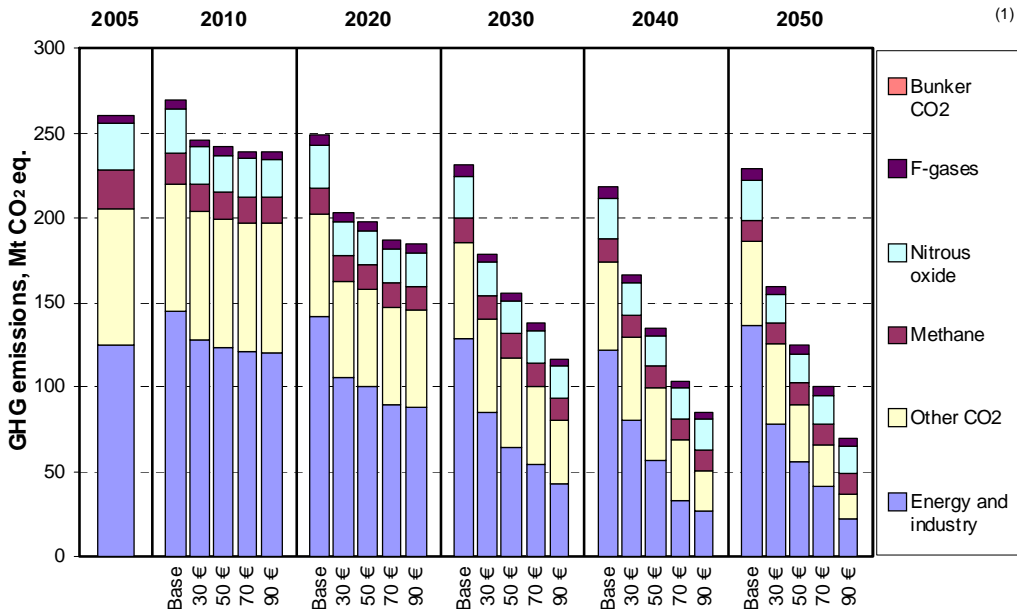

Figure 8.2. Greenhouse gas emissions in the Nordic countries. Exogenous allowance prices are set in the model to increase gradually from 20 €/tonne in 2010 to 30, 50, 70 or 90 €/t CO<sub>2</sub> in 2040. The maximum GHG reduction from the 2005 level is above 75%.

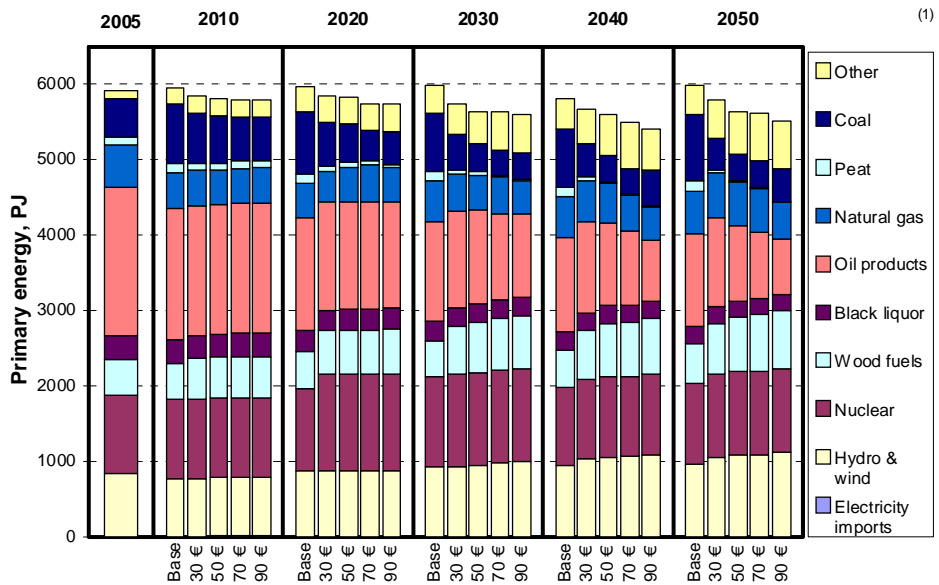

Figure 8.3. Primary energy supply in the Nordic countries. Exogenous allowance prices are set in the model to increase gradually from 20 €/tonne in 2010 to 30, 50, 70 or 90 €/t CO<sub>2</sub> in 2040.

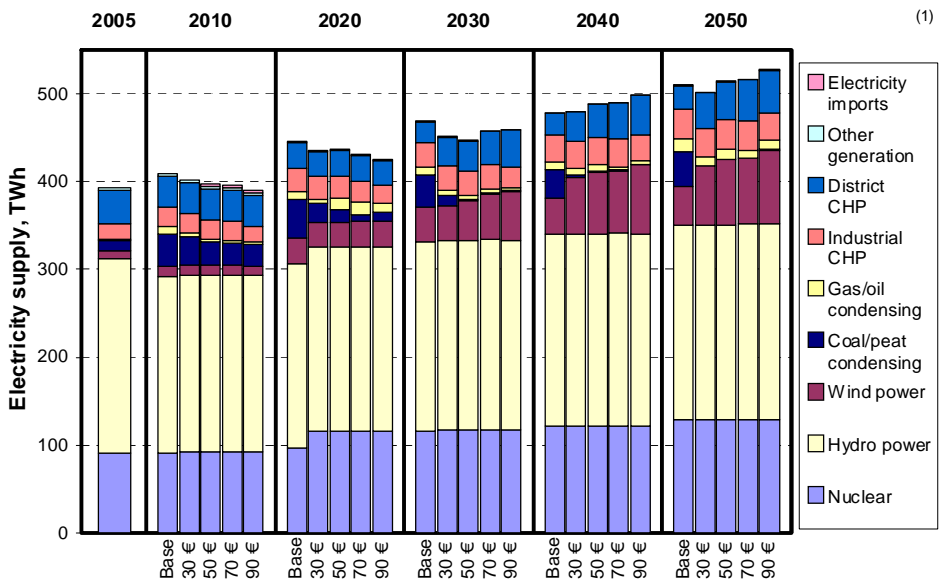

Figure 8.4. Total net electricity supply in the Nordic countries. Exogenous allowance prices are set in the model to increase gradually from 20 €/tonne in 2010 to 30, 50, 70 or 90 €/t CO<sub>2</sub> in 2040.

8. Future role for CCS in the Nordic countries

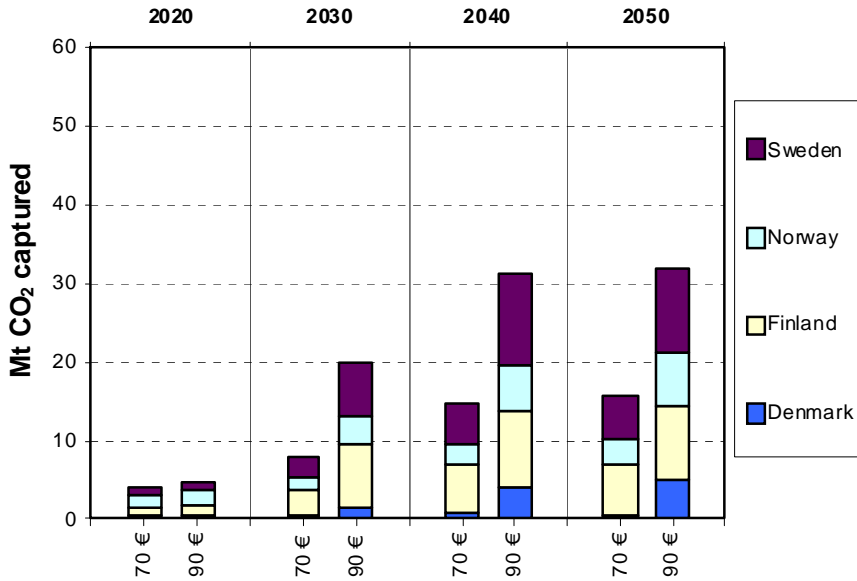

Figure 8.5. Amount of CO<sub>2</sub> captured annually in each Nordic country with the option for bio-CCS excluded. Exogenous allowance prices are set in the model to increase gradually from 20 €/tonne in 2010 to 30, 50, 70 or 90 €/t CO<sub>2</sub> in 2040.

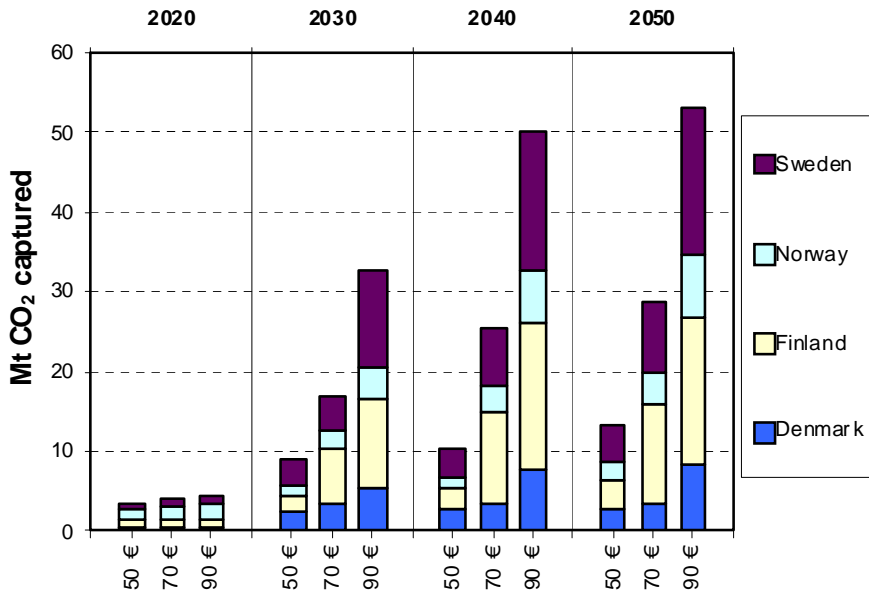

Figure 8.6. Amount of CO<sub>2</sub> captured annually in each Nordic country with the option for bio-CCS included. Exogenous allowance prices are set in the model to increase gradually from 20 €/tonne in 2010 to 30, 50, 70 or 90 €/t CO<sub>2</sub> in 2040.

Figure 8.7 shows, which countries or regions would need to export their CO<sub>2</sub> to the North Sea due to either lack of own storage sites or due to more expensive CO<sub>2</sub> storage options nearby emission sources. The scenario results indicate that with the assumed inputs for CO<sub>2</sub> transport and storage the competition of the Norwegian storage capacities with Central European countries could be minor by 2050 due to large enough storage capacities in the Western and Eastern Europe. Even the sensitivity analysis with 50% reduction of the storage capacity in Continental Europe showed no difference to the results in Figure 8.7 by 2050. After the year 2050, the competition of the Norwegian storage capacities would become higher due to decreasing storage capacities in Continental Europe. However, cost effective solutions for large scale CO<sub>2</sub> infrastructures could motivate to form source clusters with a shared infrastructure around the North Sea basin including both Central European and Nordic countries (see Chapter 8.4). These types of investments have not been taken into account in the scenario calculations. The scenario calculations do not either include any detailed infrastructure optimisation.

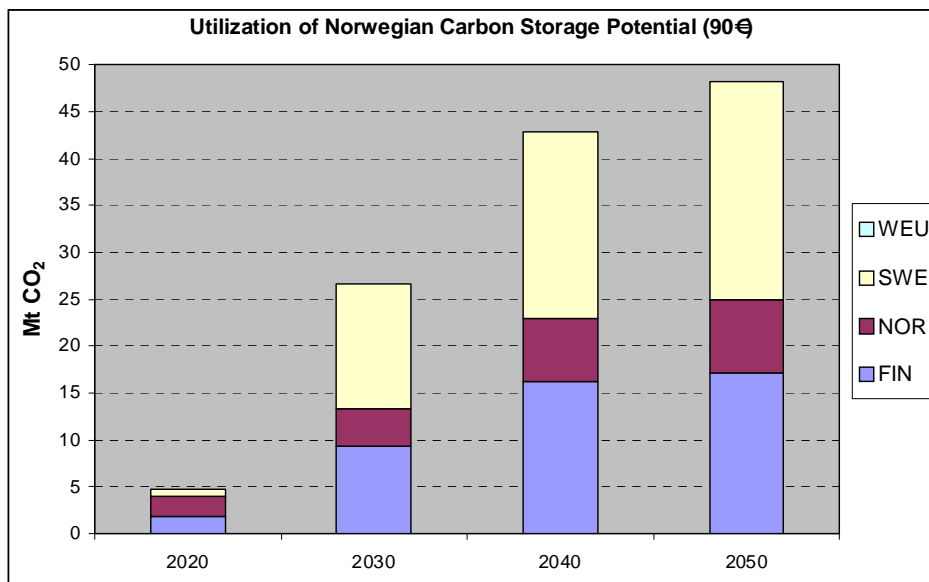

Figure 8.7. Competition of the Norwegian storage capacities at an emission allowance price of 90 €/t by 2040. Y-axis shows amount of CO<sub>2</sub> stored annually. WEU: Western Europe; FIN: Finland; NOR: Norway; SWE: Sweden.

## 8.2 Regional potential for CCS adaptation

The maps created based on the CO<sub>2</sub> emission database (Chapter 2) reveal several interesting regions containing point sources of CO<sub>2</sub> that could be possible candidates for CCS. In this chapter, clusters of point sources have been identified and their suitability for CCS application have been coarsely evaluated, taking into account CO<sub>2</sub> emissions, technological feasibility for CO<sub>2</sub> capture, location of point source emission, as well as transportation and storage possibilities. Also, facilities with high potential for early CCS adaption have been identified. The clusters are shown in Figure 8.8.

The categorization of point source emissions is commonly based on the location of the emission sources, the industry sector from where the emissions originate, the amount of CO<sub>2</sub> emitted annually, and the location of the emission sources compared to the storage site and/or transportation points such as railroad, harbours and pipelines. One benefit from cluster formation is that the transportation of CO<sub>2</sub> can be jointly handled. It could also be possible to channel flue gases from several adjacent point sources to one joint capture unit, either locally or regionally, depending on the number and size of the emission sources.



## 8. Future role for CCS in the Nordic countries

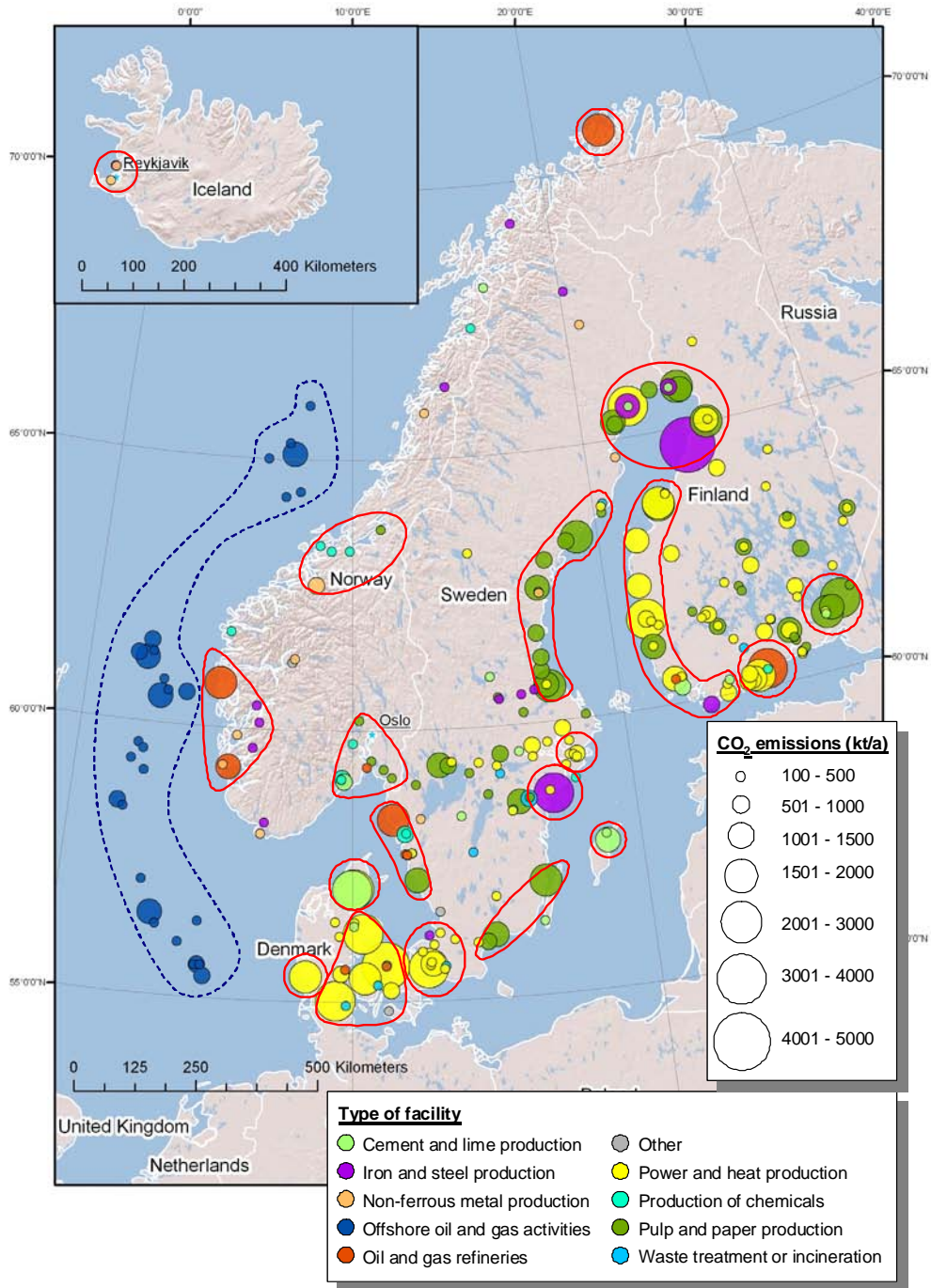

Figure 8.8. Identified CO<sub>2</sub> emission clusters (note: map showing total, i.e. fossil plus biogenic, CO<sub>2</sub> emissions). The map can also be found in Appendix B.

### 8.2.1 Helsinki region (FI)

The majority of the Finnish point sources of fossil CO<sub>2</sub> are located along the coastal line of Finland. The geographically most compact cluster of significant point sources is located around the Helsinki region.

The largest of these sources (emitting 2.8 Mt/a fossil CO<sub>2</sub><sup>25</sup>) is the oil refinery in Kilpilahti, Porvoo, located 40 km east of Helsinki. One of Europe's largest CO<sub>2</sub> production facilities is located at the oil refinery, producing 0.4 Mt CO<sub>2</sub> per year by separating CO<sub>2</sub> in conjunction with a process producing hydrogen from natural gas. The CO<sub>2</sub> is separated by a pressure swing absorption process located after the steam reforming unit. The CO<sub>2</sub> is liquefied and transported by ship tankers for sale to the Nordic countries, Baltic Countries, Russia, and Poland. It is currently unclear how much of the CO<sub>2</sub> could be captured by applying additional capture units to the refinery. The Porvoo refinery has around 40 different processing units, which may make it very difficult to apply CCS (Kilpilahti, 2010). According to IEA (2008), the main sources of CO<sub>2</sub> in the petrochemical industry are steam boilers and CHP plants. The technology for CO<sub>2</sub> capture from large-scale CHP plants would be similar to that of other power plants.

The rest of the larger point sources are combined heat and power plants. The two CHP plants at Vuosaari, Helsinki, were built in the 1990's and combust natural gas (1.7 Mt/a fossil CO<sub>2</sub>). The plants are combined cycle power plants with a total production output of 630 MW of electricity and 580 MW of district heat. The coal-fired power plant at Hanasaari, Helsinki, was built in 1974 and has an output capacity of 220 MW electricity and 445 MW district heat (1.1 fossil CO<sub>2</sub>). The two coal-fired power plants at Salmisaari, Helsinki, have a total output of 160 MW electricity 480 MW district heat (1.0 Mt/a fossil CO<sub>2</sub>). The CHP plant at Suomenoja, Espoo, is located 15 km west of Helsinki centre and has an output of 125 MW electricity and 373 MW district heat (0.82 Mt/a fossil CO<sub>2</sub>). The plant consists of three units, combusting coal, natural gas and oil. A new combined cycle power plant was completed in 2009 at the same site at Suomenoja. The new power plant uses natural gas as fuel and has an output of 234 MW electricity and 214 MW district heat. The natural gas and coal-fired CHP plant at Martinlaakso, Vantaa, is located 15 km north of Helsinki and emit-

---

<sup>25</sup> All plant-specific CO<sub>2</sub> emission data is taken from the database containing emission data 2007.

ted 0.7 Mt fossil CO<sub>2</sub> in 2007. Together with the Porvoo refinery, the fossil CO<sub>2</sub> emissions from this cluster amounts to 8.1 Mt.

Considering the large distances to mature storage sites, ship transportation of CO<sub>2</sub> would be the most likely transportation option for the Helsinki region. The Porvoo refinery has the largest port in Finland in terms of volume of cargo throughput. Almost 20 million tons crude oil and petroleum products pass through the harbour annually. The new Helsinki harbour for goods opened in 2008 at Vuosaari and took over the operations of the two previous container harbours in Helsinki.

Table 8.1. Summary of the Helsinki region cluster.

Fossil CO <sub>2</sub> emissions (Mt/a):	8.1
Biogenic CO <sub>2</sub> emissions (Mt/a):	0
Number of plants with emissions >100 kt/a CO <sub>2</sub> :	7
Types of plants:	Oil refinery (1), CHP plants (7)
Prerequisites for CCS application:	Several large point sources of fossil CO <sub>2</sub> emissions, existing industrial CO <sub>2</sub> production, close to harbours.
Challenges:	Far away from mature storage-sites.

### 8.2.2 Northern shore of the Gulf of Bothnia (FI, SE)

The northern-most part of the Gulf of Bothnia has several large point sources of CO<sub>2</sub>, from the steel works at Raahe in the east to the steel works and heat and power plant at Luleå in the west. There are also several pulp and paper factories in the area, emitting large amounts of biogenic CO<sub>2</sub>. It should be noted that the distance between the easternmost and the westernmost plants is quite large. However, the potential for common transport infrastructure, probably by ship, could be promising. Considering the fact that there are several large point sources within a fairly close distance, the cluster could be of relevance for CCS. The plants around Luleå in Sweden have access both to harbour facilities and to the railroad between Luleå and Narvik in Norway.

Three steel works reside in the area: the integrated steel works at Raahe (4.7 Mt/a fossil CO<sub>2</sub>), the sheet metal plant at Luleå (1.4 Mt/a fossil CO<sub>2</sub>) and the stainless steel works at Tornio (0.6 Mt/a fossil CO<sub>2</sub>). The production capac-

ity of ferrochrome at Tornio will double in the upcoming years, which will increase the annual emissions by 0.27 Mt/a (Outokumpu, 2008). The direct CO<sub>2</sub> emissions at the steel works come from blast furnaces and other iron ore reduction processes, combustion of fossil fuels, lime kilns, and other process-related emissions. Although certain gas streams at steel works have a higher CO<sub>2</sub> concentration in certain gas streams than power plant flue gas, the high number of various gas streams to be treated and the restricted availability of heat pose additional challenges to applying CCS to steel works.

Three power plants are also located in this area; the CHP plant at Luleå (2.2 Mt/a fossil CO<sub>2</sub>), the CHP plants at Toppila (1.3 Mt/a fossil CO<sub>2</sub>), and the power plant at Oulu (0.3 Mt/a fossil CO<sub>2</sub>). There are also two lime kilns, emitting 0.1 Mt/a fossil CO<sub>2</sub> each, but these are too small for CCS applications.

There are six large pulp and paper plants in this region, including the integrated pulp and paper plants at Veitsiluoto, Oulu and Kalix, the pulp plant in Kemi, and the Kraftliner plants in Piteå and Munksund. The largest part of the emissions is biogenic CO<sub>2</sub> (for example from combustion of black liquor), which amounts to 7 Mt/a. However, the same uncertainties as mentioned earlier with applying CCS to recovery boilers apply to these.

The steel plants produce large amounts of steelmaking slag that could be used for mineralisation of CO<sub>2</sub>. However, the theoretical storage capacity of slag could only take a small part of the annual CO<sub>2</sub> emissions. For instance, if all slag produced at the Raahe steel plant was mineralized with CO<sub>2</sub> at a conversion efficiency of 100% the annual emissions of the Raahe steel plant could theoretically be reduced with 7-8% (Teir, 2008). In practice, the conversion efficiency would be much lower and a large part of the slag has commercial value. The blast furnace slag (roughly half of the steelmaking slag production at Raahe) is used as structural layer material, a stabilizing agent in earthworks and road construction, for liming purposes in agriculture and as a raw material in the cement industry.

Together the facilities emit over 11 Mt fossil CO<sub>2</sub> annually, which makes a significant cluster of CO<sub>2</sub> emissions. Although the facilities are located on the perimeter of a half circle with a radius of about 100 km, the facilities are all located close to the coast line, allowing for ship transportation of CO<sub>2</sub>. However, the transportation distance by ship for instance to the Utsira formation is over 2000 km. Another storage option is the Melkøya LNG plant, which is located about 600 km to the north of the area and has an existing CO<sub>2</sub> pipeline connection for storage at the Snøhvit formation. This could provide an opportunity for

joint pipeline transportation of captured CO<sub>2</sub> to the Barents Sea for storage below the seabed. In addition, the pipeline route could also provide for transportation of natural gas back to the Northern-most part of the Gulf of Bothnia.

Table 8.2. Summary of the northern shore of the Gulf of Bothnia.

Fossil CO <sub>2</sub> emissions (Mt/a):	11.7
Biogenic CO <sub>2</sub> emissions (Mt/a):	7.4
Number of plants with emissions >100 kt/a CO <sub>2</sub> :	14
Types of plants:	Steel works (3), CHP plants (3), Pulp and paper plants (6), lime production (2).
Prerequisites for CCS application:	Several large point sources of fossil CO <sub>2</sub> emissions; existing industrial CO <sub>2</sub> production; close to harbours; opportunity for pipeline connection to the Melkøya LNG plant.
Challenges:	Distance to mature storage formations (Utsira) > 2000 km by ship; most emissions from process industry.

### 8.2.3 South-western coast line of Finland (FI)

The rest of the coast line of Finland, ranging from Kokkola to Inkoo, has also several significant large point sources and clusters of CO<sub>2</sub> emissions. The majority of these are power plants and pulp and paper plants.

The coastal region around Pori represent the largest cluster of these, including a few large power plants, of which the Meri-Power coal-fired condensing power plant at Tahkoluoto is the largest (2.5 Mt/a fossil CO<sub>2</sub>). The power plant was built in 1994 and has a power output of 565 MW electricity. The Tahkoluoto coal-fired condensing power plant (235 MW electric capacity) is located at the same site and shares the same flue gas stack as the Meri-Pori plant (0.98 Mt/a fossil CO<sub>2</sub>). Two smaller power plants are also located nearby; but these plants are too small to be considered for CO<sub>2</sub> capture (0.3 Mt/a fossil CO<sub>2</sub> each). A new, biomass-fired power plant started up at Kaanaa in Pori in 2008. The new power plant generates electricity at 65 MW, steam at 140 MW and district heating at 70 MW. A CCS solution is currently being developed for the Meri-Pori power plant (see Chapter 5.2).

Table 8.3. Summary of the south-western coast of Finland.

Fossil CO <sub>2</sub> emissions (Mt/a):	12.8
Biogenic CO <sub>2</sub> emissions (Mt/a):	4.3
Number of plants with emissions >100 kt/a CO <sub>2</sub> :	19
Types of plants:	Condensing coal-fired power plants (4), steel works (1), district heat plant (1), CHP plants (8), pulp and paper plants (2), cement plant (1), oil refinery (1), lime factory (1).
Prerequisites for CCS application:	Several large point sources of fossil CO <sub>2</sub> emissions; close to harbours.
Challenges:	1500–2000 km distance to mature storage-sites (Utsira); relatively large distances between clusters.

Several smaller clusters can be found on the coast line. One is Alholmen, Pietarsaari, consisting of a CHP plant (1.5 Mt/a fossil CO<sub>2</sub> and 0.4 Mt/a biogenic CO<sub>2</sub>) and a pulp and paper factory (0.1 Mt/a fossil CO<sub>2</sub> and 1.9 Mt/a biogenic CO<sub>2</sub>). The Turku region is another cluster, consisting of a CHP plant, oil refinery, and cement plant, producing in total 2.5 Mt/a fossil CO<sub>2</sub>.

Other notable single large sources are the CHP plant at Vaasa (1.3 Mt/a fossil CO<sub>2</sub>), the condensing power plant at Kristiinankaupunki (1.0 Mt/a fossil CO<sub>2</sub>), the steel mill at Koverhar (0.9 Mt/a fossil CO<sub>2</sub>), the condensing coal fired plant at Inkoo (0.9 Mt/a fossil CO<sub>2</sub>) and the pulp factory at Rauma (1.3 Mt/a biogenic CO<sub>2</sub>).

#### 8.2.4 Imatra region (FI)

In the south-eastern part of Finland, close to the Russian border, several pulp and paper plants are located inside a 20 km radius: Imatra (2.53 Mt/a biogenic and 0.18 Mt/a fossil CO<sub>2</sub>), Kaukaa plant in Lappeenranta (1.70 Mt/a biogenic and 0.16 Mt/a fossil CO<sub>2</sub>) and Joutseno plant (1.26 Mt/a biogenic CO<sub>2</sub>). In total, these three plants produce over 5 Mt/a CO<sub>2</sub>, which is of mostly biogenic origin. A large part of the biogenic CO<sub>2</sub> emissions originate from the chemical recovery boiler used in the pulp production. However, the current EU emission trading system does not offer any benefit for using CCS to capture biogenic emissions,

because the trading system does not include CO<sub>2</sub> emissions of biogenic origin. Therefore, very little attention has been given to application of CCS to recovery boilers. The challenges for application existing recovery boilers with CCS have not been evaluated in detail, and the cost range has not been verified.

Table 8.4. Summary of the Imatra region.

Fossil CO <sub>2</sub> emissions (Mt/a):	1.2
Biogenic CO <sub>2</sub> emissions (Mt/a):	5.6
Number of plants with emissions >100 kt/a CO <sub>2</sub> :	7
Types of plants:	pulp and paper plants (3), cement and lime plants (2), oil refinery (1), lime factory (1), CHP plant (1).
Prerequisites for CCS application:	A few large point sources of biogenic CO <sub>2</sub> emissions, relatively close to coast.
Challenges:	About 1800 km distance to mature storage-sites (Utsira), most emissions biogenic and from process industry.

### 8.2.5 Mid-eastern coast line of Sweden (SE)

The mid-eastern coast line of Sweden, ranging from Umeå to Gävle, contains several large pulp and paper plants emitting mostly biogenic CO<sub>2</sub>.

One cluster is located about 100 kilometres south of Umeå, where there are two pulp and paper plants emitting in total over 2 Mt/a of CO<sub>2</sub>, of which 95% is of biogenic origin (Husum and Domsjö). The plant in Husum is the largest of the two and emits itself close to 2 Mt/a. It is an integrated pulp and paper mill producing both uncoated and coated fine paper as well as bleached pulp.

Around the municipality of Sundsvall there are three plants emitting over 100 kt/a of CO<sub>2</sub>. Two of these are pulp and paper plants and one is an aluminium plant. The total emissions are close to 2 Mt/a, of which about 85% is of biogenic origin. The majority of the fossil CO<sub>2</sub> emissions originate from the aluminium production plant, whereas the largest emission source, regardless of origin, is Östrands massabruk (SCA), producing chlorine-free bleached softwood sulphate pulp. All plants within this cluster have access to a harbour.

## 8. Future role for CCS in the Nordic countries

Around Gävle there are four plants located close to the coast emitting over 4 Mt/a biogenic CO<sub>2</sub>. Apart from these plants there are also a number of smaller plants located around 50 kilometres inland (these are not included in the cluster). The largest of the coast-based fossil emitters is Karskärsverket emitting some 116 kt/a of fossil CO<sub>2</sub>. However, regardless of CO<sub>2</sub> origin, Korsnäsverken, emits far more CO<sub>2</sub> (1.46 Mt/a, almost only of biogenic origin). Korsnäsverken produces sulphate pulp, paper and paper board and could be an interesting plant for bio-CCS.

Table 8.5. Summary of the mid-eastern coast line of Sweden.

Fossil CO <sub>2</sub> emissions (Mt/a):	0.77
Biogenic CO <sub>2</sub> emissions (Mt/a):	9.3
Number of plants with emissions >100 kt/a CO <sub>2</sub> :	14
Types of plants:	pulp and paper plants (8), aluminium production (1), CHP plant (2), waste incineration (1).
Prerequisites for CCS application:	Several large point sources of biogenic CO <sub>2</sub> emissions; located close to harbours.
Challenges:	1500–1900 km distance to mature storage-sites (Utsira); relatively large distances between clusters; most emissions biogenic and from process industry.

### 8.2.6 Stockholm region (SE)

In the Stockholm region most plants emitting more than 100 kt/a are power and heat production plants. There is also a chemical refinery (Nynas) with production of mainly naphthenic oils, bitumen and marine and other specialty fuels. All plants are located at or close to a harbour, but their individual emissions are quite small.



Table 8.6. Summary of the Stockholm region.

Fossil CO <sub>2</sub> emissions (Mt/a):	1.0
Biogenic CO <sub>2</sub> emissions (Mt/a):	0.7
Number of plants with emissions >100 kt/a CO <sub>2</sub> :	6
Types of plants:	Power & heat production (5), production of chemicals (1)
Prerequisites for CCS application:	Experience with CCS testing at Värtaverket, close to harbours.
Challenges:	Distance to mature storage-sites, several relatively small (<< 1 Mt/a) emitters of CO <sub>2</sub> , from which CO <sub>2</sub> capture would probably not be feasible.

The largest CO<sub>2</sub> emitter in 2007 was Värtaverket, which is located quite centrally in Stockholm and produces power and district heating mainly from coal. The total emissions in 2007 from this plant amounted to 0.8 Mt/a (> 80% fossil CO<sub>2</sub>). The coal combustion in Värtaverket is based on PFBC (pressurised fluidised bed combustion) technique. High pressures makes CO<sub>2</sub> capture easier, which makes PFBC attractive for CCS purposes. CO<sub>2</sub> capture with potassium carbonate as sorbent (i.e. Sargas technology) was tested during November 2007 to February 2008 with a capturing rate exceeding 95%. Despite the high capturing rate, the evaluation was not in favour of CCS due to estimated high costs for transportation and storage. However, the technique was deemed feasible. Furthermore, the plant is located at a harbour. It is also worth mentioning that the owner of Värtaverket (Fortum) plans for a major investment in a new biomass-fired CHP plant at Värtaverket.

### 8.2.7 Oxelösund region (SE)

Sweden's largest point source of carbon dioxide is the steel plant in Oxelösund. It emits around 2.4 million tons of carbon dioxide yearly, of which all is of fossil origin. It is located at a harbour. Close to the steel work is Idbäckens Kraftvärmeverk – a power and heat production plant emitting a small amount of carbon dioxide, mainly biogenic.

## 8. Future role for CCS in the Nordic countries

The steel work could definitely be of interest for CCS due to relatively high fossil CO<sub>2</sub> emissions and the location at a harbour. However, there are additional challenges with applying CCS to process industry, as mentioned earlier. Furthermore, there are also other large point sources relatively close to Oxelösund.

Table 8.7. Summary of the Oxelösund region.

---

Fossil CO <sub>2</sub> emissions (Mt/a):	2.4
Biogenic CO <sub>2</sub> emissions (Mt/a):	0.2
Number of plants with emissions >100 kt/a CO <sub>2</sub> :	2
Types of plants:	Iron & steel (1), power & heat production (1).
Prerequisites for CCS application:	Large emissions from the steel plant; close to harbours.
Challenges:	About 1200 km to mature storage-sites (Utsira); challenges with applying capture technology to steel plants.

---

### 8.2.8 Gotland region (SE)

Gotland is Sweden's largest island and has two cement and lime plants with emissions exceeding 100 kt/a. One of them is actually among the top ten of Swedish CO<sub>2</sub> emitters (Slitefabriken) with 1.4 Mt/a – all fossil CO<sub>2</sub>. About 12 kilometres north of Slitefabriken is the lime production plant (Kalkproduktion Storugns AB), emitting some 170 kt/a.

Table 8.8. Summary of the Gotland region.

Fossil CO <sub>2</sub> emissions (Mt/a):	1.6
Biogenic CO <sub>2</sub> emissions (Mt/a):	0
Number of plants with emissions >100 kt/a CO <sub>2</sub> :	2
Types of plants:	Cement and lime production (2).
Prerequisites for CCS application:	Large fossil emissions from the cement plant, located at a harbour, near a possible (but unexplored) storage area south-east of Gotland).
Challenges:	1300 km to mature storage sites (Ut-sira), challenges with applying capture technology to cement plants.

The calcination of calcium carbonate in lime kilns, used in both cement and lime manufacturing, results in high concentrations of CO<sub>2</sub> (25–35%) (IEA, 2008). Due to the fact that Slitefabriken is both a large point source of CO<sub>2</sub>, has high CO<sub>2</sub> concentration, is located at a harbour and close to one of Sweden's only potential storage sites, further investigation of application potential to CCS should be encouraged. That is one of the reasons that MinFo (Swedish Mineral Processing Research Association) and Umeå University are now, with support from the Swedish Energy Agency, studying the potential for oxy-fuel combustion at cement and lime plants.

### 8.2.9 South-east region of Sweden (SE)

Several large pulp and paper plants are located in the south-east region of Sweden as well: in Nymölla (0.8 Mt/a biogenic CO<sub>2</sub>), Mörrum (1.1 Mt/a biogenic CO<sub>2</sub>) and Mönsterås (1.9 Mt/a biogenic CO<sub>2</sub>). If CCS applications for pulp and paper plants become feasible, these plants may be better candidates for CCS applications, since they are located closer to potential storage sites than most other pulp and paper plants in Sweden.

A power plant is located close to the Nymölla plant, but since its emissions were as low as 0.1 Mt/a CO<sub>2</sub> in 2007 it has been left outside the cluster.

Table 8.9. Summary of the South-east region of Sweden.

Fossil CO <sub>2</sub> emissions (Mt/a):	3.8
Biogenic CO <sub>2</sub> emissions (Mt/a):	0.1
Number of plants with emissions >100 kt/a CO <sub>2</sub> :	3
Types of plants:	Pulp and paper plants (3).
Prerequisites for CCS application:	Large emission sources; located at the coast line; relatively close to a possible (but unexplored) storage area south-east of Gotland).
Challenges:	Biogenic emissions; technological challenges with applying capture to pulp and paper plants; 1000-1200 km to mature storage sites (Utsira).

### 8.2.10 Göteborg region (SE)

Göteborg is Sweden's second largest town and in its vicinity there are 8 point sources of CO<sub>2</sub>, most of them emitting around 100–500 kt CO<sub>2</sub> annually. The largest point source is Borealis Cracker Plant in Stenungsund, with total carbon dioxide emission amounting to 678 kt/a (all fossil). The plant produces polyethylene mainly for pipe and wire and cable applications.

Looking a bit more north and south there are two other large CO<sub>2</sub> emitting plants rather close to Göteborg. One plant, located 80 kilometres north of Göteborg, is the refinery in Lysekil (Preemraff) emitting around 1.6 Mt/a. 55 kilometres south of Göteborg there is a large pulp and paper plant (Värö bruk) emitting around 1.0 Mt/a (mostly biogenic CO<sub>2</sub>).

All mentioned plants have access to harbours, several are large point sources, and they all have rather short distance to potential storage sites in the North Sea. In conclusion, the cluster around Göteborg should be investigated further for the possibility to apply CCS. Since the refineries and chemical production plants can have very different process designs, depending on the product they are producing and often generating CO<sub>2</sub> on various locations at the plants, plant specific investigations are needed in order to determine their suitability for CCS application.

Table 8.10. Summary of the Göteborg region.

Fossil CO <sub>2</sub> emissions (Mt/a):	4.0
Biogenic CO <sub>2</sub> emissions (Mt/a):	1.7
Number of plants with emissions >100 kt/a CO <sub>2</sub> :	10
Types of plants:	Power & heat production (3). oil & gas refineries (3), production of chemicals (2), waste treatment/incineration (1), pulp & paper (1).
Prerequisites for CCS application:	Several large point sources located at harbours, short distance to storage-sites in the North Sea or possibly on-shore in Denmark.
Challenges:	Technical challenges with applying capture technology to process industry, several relatively small (<< 1 Mt/a) emitters of CO <sub>2</sub> , from which CO <sub>2</sub> capture would probably not be feasible.

### 8.2.11 Belt region (DK)

Within this cluster there are several large point sources of CO<sub>2</sub>. Most of them are power and heat plants and all have harbour access.

Asnæsværket, near Kalundborg in Denmark (western Sealand) produces electricity and district heating almost exclusively from coal (capacity 1000 MW electricity, 500 MW district heating). With its 3.3 Mt/a of CO<sub>2</sub> emissions it is the second largest point source of CO<sub>2</sub> in the Nordic countries. Located close to Asnæsværket is a refinery emitting some 500 kt/a. Another significant CO<sub>2</sub> emitting plant (also among the top ten CO<sub>2</sub> emitters in the Nordic countries) is located close to Århus in Denmark (eastern Jutland). It is a CHP plant (Studstrupværket) producing both electricity and district heating from mainly oil and coal. A small part of the fuel supply is biomass (straw). In total, the plant emits over 2.5 Mt/a, of which 93% is of fossil origin. Furthermore, a large point source (1.8 Mt/a) is Fynsværket in Odense (capacity 600 MW electricity, 800 MW district

## 8. Future role for CCS in the Nordic countries

heating). The plant has recently been rebuilt<sup>26</sup>, and is now also combusting biomass, such as straw. A third large CO<sub>2</sub> emitter is Stignæsværket (0.9 Mt/a), another coal-fired CHP plant located in south-western Sealand (capacity 400 MW electricity). Skærbækværket, close to Kolding in eastern Jutland, is another coal-fired power and heat plant emitting over 0.5 Mt/a. All the mentioned power and heat plants are located at harbours. Apart from the above mentioned plants, there are also other plants emitting smaller amounts of CO<sub>2</sub> (around < 500 kt/a).

Table 8.11. Summary of the Belt region.

Fossil CO <sub>2</sub> emissions (Mt/a):	10.6
Biogenic CO <sub>2</sub> emissions (Mt/a):	0.4
Number of plants with emissions >100 kt/a CO <sub>2</sub> :	14
Types of plants:	Power & heat production (8), waste treatment/incineration (1), oil & gas refineries (2), production of chemicals (1), cement & lime (1), other (1).
Prerequisites for CCS application:	Several large point sources located at harbours, short distance to storage-sites in the North Sea or possibly on-shore in Denmark.
Challenges:	A few relatively small (<< 1 Mt/a) emitters of CO <sub>2</sub> , from which CO <sub>2</sub> capture would probably not be feasible.

To sum up, within the Belt region there are several large point sources of CO<sub>2</sub>. Altogether there are five large point sources (> 0.5 Mt/a) located at the coastline, totally emitting almost 9 Mt/a. All these are power and heat producing plants. Although some plants are quite old and thereby maybe not the most suitable for application to CCS, it is definitely of interest to further investigate the opportunities for CCS coordination in these regions. Adding to these there are also two refineries each emitting almost 0.5 Mt/a CO<sub>2</sub> and some smaller plants as well.

---

<sup>26</sup> The plant-specific CO<sub>2</sub> emission data used in the database and maps is for year 2007, before the plant was rebuilt.

### 8.2.12 Öresund region (DK, SE)

Öresund is a sound between Sweden and Denmark, with especially two large point sources of CO<sub>2</sub> emissions in Denmark. Both are power and heat production plants generating about 2.8 Mt/a (Avedøreværket) and 1.5 Mt/a (Amagerværket) fossil CO<sub>2</sub>. The fact that these two plants alone emit more than 4 Mt/a, together with a reasonable nearness to potential storage sites make this cluster highly interesting for further investigation. All other plants in the Öresund region are mainly medium point sources with CO<sub>2</sub> emission of 100–400 kt/a. Although almost all of these are located at the coast with access to harbours, the potential for application to CCS needs to be further investigated.

Table 8.12. Summary of the Öresund region.

Fossil CO <sub>2</sub> emissions (Mt/a):	5.0
Biogenic CO <sub>2</sub> emissions (Mt/a):	1.6
Number of plants with emissions >100 kt/a CO <sub>2</sub> :	12
Types of plants:	Power & heat production (9), Iron & steel (1), other (1), waste treatment/incineration (1),
Prerequisites for CCS application:	Several large point sources located at harbours, short distance to storage-sites in the North Sea or possibly on-shore in Denmark.
Challenges:	Technical challenges with applying capture technology to process industry, several relatively small (<< 1 Mt/a) emitters of CO <sub>2</sub> , from which CO <sub>2</sub> capture would probably not be feasible.

### 8.2.13 Aalborg region (DK)

The Aalborg region comprises two of the Nordic countries' top five CO<sub>2</sub> point sources, namely one CHP plant (Nordjyllandsværket, 700 MW electricity, 450 MW district heating) and one cement production plant (Aalborg Portland). Both these plants emit almost 2.8 Mt/a. They are located very close to each other at

the Limfjord with harbour access. Part of the CHP plant is very modern and has a world record in high efficient coal-utilisation for both condensing power mode (i.e. 47% LHV) and CHP. It should also be noted that the owner, Vattenfall, is at present investigating the possibilities for CO<sub>2</sub> onshore storage very close to Nordjyllandsværket in the Vedsted Structure (see Chapter 5.2). If feasible, the CHP plant will be retrofitted for post-combustion capture of CO<sub>2</sub>. The cement production plant with high concentration of CO<sub>2</sub> may also be suitable for CCS.

Altogether, this cluster of two large point sources, potentially with high CO<sub>2</sub> concentration, is of great interest. Investigations are already carried out on the possibility of application to CCS.

Table 8.13. Summary of the Aalborg region.

Fossil CO <sub>2</sub> emissions (Mt/a):	5.5
Biogenic CO <sub>2</sub> emissions (Mt/a):	0
Number of plants with emissions >100 kt/a CO <sub>2</sub> :	2
Types of plants:	CHP plant (1), cement production (1).
Prerequisites for CCS application:	CCS demonstration planning initiated at one plant; plants located close to each other with harbour access; short distance to storage-sites in the North Sea or possibly on-shore in Denmark.
Challenges:	Technical challenges with applying capture technology to cement production.

#### 8.2.14 Esbjerg CHP plant (DK)

The Esbjerg power station is the only large (> 0.1 Mt/a CO<sub>2</sub>) point source of CO<sub>2</sub> at the west coast of Denmark, emitting 1.8 Mt fossil CO<sub>2</sub> in 2007. The CHP plant was built in 1992 and is one of the world's most efficient coal-fired power plants, which makes it an ideal candidate for CCS retrofit. The plant is located at the Esbjerg harbour and is located relatively close to mature storage-sites in the North Sea.



### 8.2.15 Melkøya LNG plant (NO)

The Melkøya LNG processing plant at Hammerfest is the only major point emission source in the northern part of Norway. The plant is directly connected by pipeline to the gas fields of Snøhvit, Albatross and Askeladd, which are located in the seabed below the Barents Sea about 160 km off the coastline. A carbon capture system was constructed together with the plant and is currently in operation. CO<sub>2</sub> from the incoming natural gas (5–8%) is captured and sent back by pipeline to a sandstone formation below the Snøhvit field. During start-up of the facilities in 2007 the CO<sub>2</sub> emissions were exceptionally high, reaching about 1.6 Mt fossil CO<sub>2</sub>, mainly due to flaring. For comparison, the plant emitted only 0.8 Mt fossil CO<sub>2</sub> in 2009 (Statoil 2010).

The Melkøya plant also serves as an LNG export terminal and thus an extensive harbor system has been established. This opens up for transportation of CO<sub>2</sub> to Melkøya by tanker. However, when the amount of CO<sub>2</sub> to be transported from Melkøya to Snøhvit (or other fields in the Barents Sea) increases, it is likely that more pipelines are needed.

In April 2010 Norway and Russia agreed on the delineation of the long-disputed Barents Sea, opening new areas with possible oil and gas resources. The Melkøya processing plant and carbon capture plant can thus play vital roles in carbon capture connected to future exploitations of oil and gas from the seabed in the Barents Sea. A new 100 MW gas-fired power plant (700–800 GWh/a) is planned built at Rossmola, 2 kilometers from Melkøya by the energy company Hammerfest Energi AS. The gas, supplied via Melkøya from the Snøhvit field, will be delivered by pipelines. CO<sub>2</sub> will be separated at the power plant using the Siemens PFBC technology and returned to Melkøya for re-injection in the Snøhvit field together with CO<sub>2</sub> from the LNG plant. The status of the new power plant project is at the time of writing on hold (Hammerfest Energi AS, 2010).

### 8.2.16 Mid-west region of Norway (NO)

The Mid-west region cluster is represented by different industries such as non-ferrous metal (aluminum smelting), pulp and paper and chemicals production. The largest point source is the aluminium production plant at Sunndal (0.6 Mt/a fossil CO<sub>2</sub>) and the total fossil CO<sub>2</sub> emissions from this region were only 1.3 Mt in 2007.

## 8. Future role for CCS in the Nordic countries

CCS retrofit technologies are more challenging in this region, since a large part of the CO<sub>2</sub> originates from various industrial processes. Especially in aluminum smelters the CO<sub>2</sub> concentration of the flue gases is so low (~1%) that CCS would probably be deemed prohibitive owing to the high energy penalty of current capture technologies.

However, all of the point sources are located at the coastline and either own or have access to an extensive harbour systems for tanker transportation of CO<sub>2</sub>. The region is situated around 700–800 km from the Utsira and Johansen formations, where there are mature possibilities for storage below the seabed.

The most promising option for CCS application in this region is probably the industry situated around the Nyhamna natural gas export facility and the Tjeldbergodden natural gas processing plant. The Tjeldbergodden industrial complex has four major operating units; a gas receiving terminal, a methanol plant, an air separation plant and a gas liquefaction plant. Tjeldbergodden is equipped with a harbor installation for large tankers that can be used for transportation of CO<sub>2</sub> (Statoil, 2010). The Nyhamna facility is connected by pipeline to the Ormen Lange offshore gas field. Also new gas fields like Luva and Linnorm can be connected to the Nyhamna plant via pipeline. With the receiving terminal and an extensive pipeline network Nyhamna stands out as a favourable candidate for a CO<sub>2</sub> transportation linkage (Statoil, 2010).

Table 8.14. Summary of the mid-west region of Norway.

Fossil CO <sub>2</sub> emissions (Mt/a):	1.3
Biogenic CO <sub>2</sub> emissions (Mt/a):	0.3
Number of plants with emissions >100 kt/a CO <sub>2</sub> :	5
Types of plants:	Aluminium production (1), production of chemicals (3), pulp and paper production (1).
Prerequisites for CCS application:	A new power plant with prerequisites for CO <sub>2</sub> capture being planned; harbour access; short distance to storage-sites in the North Sea.
Challenges:	Relatively small (<< 1 Mt/a) point sources of CO <sub>2</sub> , from which CO <sub>2</sub> capture would probably not be feasible in most cases.

A new gas-fired power plant is planned to Elnesvågen in Fræna, close to the Tjeldbergodden refinery. The future power plant has been granted emission permit for CO<sub>2</sub> provided that a process for capturing CO<sub>2</sub> will be installed and operating from the beginning of the power production. The decision to start building the power plant is currently on hold as the CO<sub>2</sub> requirements in the permit have been heavily protested against in political and industrial circles (Reistad, 2010).

### 8.2.17 South-east region of Norway (NO)

The south-east region consists of several smaller point source emissions, mostly from pulp and paper production and production of chemicals. The largest emission source in this region is the cement plant in Brevik, Telemark (0.9 Mt/a fossil CO<sub>2</sub> and 0.1 Mt/a biogenic CO<sub>2</sub>). Most of the point source emissions are located at or close to the coast line and can be transported by tankers to underground storage below the seabed.

A new gas-fired power plant is planned at Herøya, inside the south-east region cluster. The establishment of such a power plant is currently dependent on a gas pipeline for gas supply. The plan is to install a carbon capture process as well, and collecting CO<sub>2</sub> from both the new power station and nearby process industry is expected to reduce the CO<sub>2</sub> emissions in Norway by up to 1 Mt yearly (Skagerak Energi AS 2009).

Table 8.15. Summary of the south-east region of Norway.

Fossil CO <sub>2</sub> emissions (Mt/a):	3.2
Biogenic CO <sub>2</sub> emissions (Mt/a):	0.7
Number of plants with emissions >100 kt/a CO <sub>2</sub> :	10
Types of plants:	Production of chemicals (4), pulp and paper production (4), oil and gas refineries (1), cement production (1).
Prerequisites for CCS application:	A new power plant with CO <sub>2</sub> capture being planned; harbour access; relatively short distance to storage-sites in the North Sea.
Challenges:	Relatively small (<< 1 Mt/a) point sources of CO <sub>2</sub> , from which CO <sub>2</sub> capture would probably not be feasible in most cases.

### 8.2.18 South-west region of Norway (NO)

The south-western region cluster represents the biggest cluster of onshore emissions in Norway, with total fossil emissions of 4.3 Mt/a CO<sub>2</sub>. This large emission rate is mainly due to the two oil and gas refineries, Mongstad and Kårstø. There are already ongoing CCS project plans for the refineries, and the potential for capture is quite well understood (see Chapter 5.2). Other industries represented in this region are non-ferrous metal production and iron and steel production.

Table 8.16. Summary of the south-west region of Norway.

Fossil CO <sub>2</sub> emissions (Mt/a):	3.2
Biogenic CO <sub>2</sub> emissions (Mt/a):	0.0
Number of plants with emissions >100 kt/a CO <sub>2</sub> :	7
Types of plants:	Oil and gas refineries (2), non-ferrous metal production (2), iron and steel production (3).
Prerequisites for CCS application:	CO <sub>2</sub> capture projects being planned at the refineries; harbour access; opportunities for CO <sub>2</sub> storage services; close to mature storage-sites in the North Sea.
Challenges:	A few relatively small (<< 1 Mt/a) point sources of CO <sub>2</sub> , from which CO <sub>2</sub> capture would probably not be feasible in most cases.

This region is the closest on-shore cluster to mature storage sites (Utsira). All the point sources are located at or very close to the coast line, enabling CO<sub>2</sub> transport either by tankers or pipeline. Both Mongstad and Kårstø could possibly serve as a joint collection points for CO<sub>2</sub> from other Nordic CO<sub>2</sub> clusters.

A new coal-fired power plant, close to the Kårstø refinery, as well as a future expansion of the Hydro Aluminium at Karmøy are planned. These could be taken into account when planning the carbon capture retrofit at the existing Kårstø refinery.

### 8.2.19 Western region of Iceland (IS)

There are three main CO<sub>2</sub> point source emissions at Iceland, all located on the west coast in the Reykjavik region: one ferroalloy production plant and two aluminium smelters. The total emissions for these point sources were 1.1 Mt fossil CO<sub>2</sub> in 2007. Owing to the low CO<sub>2</sub> concentration of the flue gases from the aluminum smelters CO<sub>2</sub> capture would be very energy intensive and probably not economically feasible.

All three point source emissions are located at the coast and either own or have access to extensive harbor systems for tanker transportation of CO<sub>2</sub>. Transportation to the nearest mature storage formations, Utsira and Johansen, is about 2500 kilometers. The topography of the northern Atlantic sea bottom makes it highly unlikely that pipeline transportation would be applied, but tanker transportation is an option.

Storage of CO<sub>2</sub> on Iceland as a solid carbonate mineral in basaltic rocks may be a possible way of storing CO<sub>2</sub> locally in Iceland in the future. One possible site for CO<sub>2</sub> storage in basalt is the Hellisheidi site in south-western Iceland, 50 km from the point sources. The feasibility of storage in basalt at Hellisheidi is currently being assessed (see Chapters 4.3.3 and 5.2.4).

Table 8.17. Summary of the south-west region of Norway.

Fossil CO <sub>2</sub> emissions (Mt/a):	1.1
Biogenic CO <sub>2</sub> emissions (Mt/a):	0.0
Number of plants with emissions >100 kt/a CO <sub>2</sub> :	3
Types of plants:	Ferroalloy production (1), aluminium smelting (2).
Prerequisites for CCS application:	Basalt storage of CO <sub>2</sub> being tested; plants located close to basalt storage site.
Challenges:	A few relatively small (<< 1 Mt/a) point sources of CO <sub>2</sub> , from which CO <sub>2</sub> capture would probably not be feasible in most cases; large distance to mature storage sites in the North Sea.

### 8.2.20 Offshore regions (NO, DK)

The offshore oil and gas sector represents approximately half of the CO<sub>2</sub> emissions in Norway. The emission allowance for the offshore sector in 2007 was about 11.1 Mt fossil CO<sub>2</sub>. Denmark's offshore emissions reached 2.1 Mt fossil CO<sub>2</sub> in 2007. The number of point sources exceeding 100 kt/a was 30 in 2007, of which the six largest had emissions of 0.9–1.2 Mt/a fossil CO<sub>2</sub> each. Most of the offshore sector is located in the southern Norwegian Sea and in the North Sea. Most offshore installations apply the same operational technology and thus have the same starting point for carbon capture retrofit technologies. The majority of the CO<sub>2</sub> emitted offshore originates from gas turbines producing the electrical power needed for compressors and pumps on the oil rigs. The rest, about 20%, comes from direct gas flaring (Kloster, 2000).

Carbon capture technologies exist and have been implemented to some extent in the offshore oil and gas sector, such as at the Sleipner field. The process operating at the Sleipner field is an amine scrubbing process operating at high pressure where CO<sub>2</sub> is separated from the natural gas from a concentration level of about 3-9%, as an integral part of the natural gas production process. The captured CO<sub>2</sub> is stored in the Utsira formation. Another promising field for large-scale CO<sub>2</sub> storage is the Johansen formation just outside of Mongstad.

The majority of the offshore point source emissions are located within 1 000 kilometers from the Utsira and Johansen formations and CO<sub>2</sub> could possibly be transported both by tankers and pipelines to the injection point(s).

The success of retrofitting an offshore platform with CCS technology depends largely on the number of emission sources and the space available on the platform. Many small process units or unit operations such as gas turbines and multiple flaring points complicate the implementation of new technologies and affects significantly the capture efficiency and investment costs. Another challenge comes from the limited space available on offshore platforms for installation of CO<sub>2</sub> capture and processing. In addition, the capture processes need power and heat, which would raise the gross CO<sub>2</sub> emissions. In the cases where the extracted natural gas contains significant concentrations of CO<sub>2</sub> CCS applications can be considered, since the capture technology is required for purification of the natural gas (as in the cases of the Sleipner and Snøhvit fields).

Table 8.18. Summary of the off-shore region.

Fossil CO <sub>2</sub> emissions (Mt/a):	8.7
Biogenic CO <sub>2</sub> emissions (Mt/a):	0.0
Number of plants with emissions >100 kt/a CO <sub>2</sub> :	30
Types of plants:	Offshore oil and gas activities
Prerequisites for CCS application:	Many offshore platforms situated at mature storage formations; existing experience from CCS applications
Challenges:	Several different CO <sub>2</sub> sources per platform, limited space for installation of CO <sub>2</sub> capture and processing equipment.

### 8.2.21 Summary of the cluster study

The review of the emission clusters show that there are several interesting possibilities for CCS application to existing facilities. Most of the largest emission sources are located along the coast lines of the Nordic countries and have harbour access, which facilitates transportation of CO<sub>2</sub> by ship. In the early stages of CCS deployment ship transportation is likely to be dominating until a pipeline infrastructure has been built.

The *coal-fired power plants in Denmark* are likely candidates for CCS applications, since these are among the largest point sources of CO<sub>2</sub> in the Nordic countries and are located close to mature storage sites. Large coal-fired power plants are also located around the Gulf of Bothnia (mainly in Finland) and at the southern coast line of Finland, but these are currently less attractive due to the distance to mature storage sites. A large part of the power plants are CHP plants (see Chapter 3.4), but most development of CCS applications focuses currently on integration with condensing power plants. Also, certain power plants are reaching the end of their life cycle and CCS application (or at least CCS-readiness) should in these cases be considered on future power plants replacing the old ones.

The most likely candidates for early CCS application are the *large natural gas refineries in Norway*, due to existing pipeline routes to mature storage sites and the experience with gas processing. The Melkøya LNG processing plant already has a functional CCS application implemented and could possibly function as a

collection point for CO<sub>2</sub> in the future. There are already plans for CCS application at Mongstad and Kårstø, but the projects have been postponed, partly due to the difficulty and cost with retrofitting operational refineries with CCS. This is true also for other retrofit activities, because retrofitting operational facilities would in many cases cause downtime of the regular operation and loss of revenue.

*Offshore platforms in the North Sea and the Norwegian Sea* stand for a significant part of the point sources of CO<sub>2</sub> and have the benefit of being located in the same region as mature storage sites. However, the challenges are many, including limited space and multiple CO<sub>2</sub> sources per platform. The Sleipner project is an example of a successful CCS application for an offshore platform, but in this case the CO<sub>2</sub> captured originates from the natural gas and separation is needed for purifying the natural gas. Therefore, other offshore platforms are not likely candidates for early CCS application.

Since production from the oil fields in the North Sea will inevitably decline at some point, there is an interest in the possibility of using captured CO<sub>2</sub> for EOR purposes as well. Preliminary estimates have suggested that up to 30 Mt CO<sub>2</sub> per year could be used for EOR purposes over a period of 15 to 25 years in the North Sea (IEA, 2008). The possibility of using CO<sub>2</sub> for EOR purposes also motivates the deployment of a CO<sub>2</sub> transportation pipeline network on the ocean floor. However, escalating investment costs for the conversion of offshore installations and wells has so far hindered the development of EOR in the North Sea.

The large CO<sub>2</sub> emissions from the *steel plants in Finland and Sweden* make them also attractive for CCS applications. Except for Oxelösund, most of the plants are located over 1500 km away (by ship) from the Utsira formation. One particularly interesting region is the northern shore of the Gulf of Bothnia, which comprises three steel plants that together emit over 6 Mt/a fossil CO<sub>2</sub>. Together with other large point sources the total fossil CO<sub>2</sub> emissions of the region amount to 11.7 Mt/a. While the CO<sub>2</sub> transportation distance by ship to the Utsira formation is over 2000 km, the Melkøya LNG plant is only located about 600 km to the north, which make pipeline transportation a more interesting solution for this region. The CO<sub>2</sub> pipeline could possibly be combined with a natural gas pipeline, transporting natural gas back to the industry cluster on the shore of the Gulf of Bothnia. However, there are large uncertainties with the feasibility of applying CCS to steel plants and more studies are needed on this.

Several clusters contain a significant part of biogenic CO<sub>2</sub> emissions, of which the largest point sources are *pulp and paper plants located mainly in Sweden and*



*Finland.* A large part of these CO<sub>2</sub> emissions originate from the chemical recovery boiler used in the pulp production, which would therefore be a possible target for CCS applications. Most of these plants are located at the coast line or close to the coast. Nonetheless, the current EU emission trading system does not include CO<sub>2</sub> emissions of biogenic origin. Therefore, there are currently very few drivers to develop CCS solutions for recovery boilers. Since the challenges and costs for retrofitting existing recovery boilers with CCS have not been evaluated in detail, it would be an important topic to investigate further into.

It should be noted that the emission clusters presented here are very rough sketches and based on bulk data for annual CO<sub>2</sub> emissions and type of industrial processes. In order to assess the true potential for CCS each plant has to be carefully evaluated. This study could be improved for instance by taking into account the CO<sub>2</sub> concentration in the flue gas, possibilities for integration of a CCS application to the plant (process specific assessment), the age of the plant and its estimated operating time left, as well as plans for expansions or replacing facilities.

### **8.3 Cost appraisals and timeline for technical realisation of systems**

In this section, the impacts of cost and time on technical realisation of CCS have been addressed. Although the situation of the Nordic countries has not been directly discussed, the trends and impacts are much the same, owing to the fact that primary energy is largely considered an international commodity. This<sup>27</sup> will also mirror the products of a nation bound for international markets characterised by fierce competition.

Capacity building within CCS has a high cost because of the complexity in systems and infrastructure that is required in order to make CCS affordable and efficient. Capacity building does not just refer to the capacities needed, also the chain of manufacturing and supplying materials have to be specialised, as well as the human resources.

---

<sup>27</sup> i.e. the cost of the products associated with the energy intensity and also the CO<sub>2</sub> footprint, which may become an issue in the future.

### 8.3.1 Impacts of fuel and technology

In consideration of cost of electricity (CoE), the fuel price is usually the most important factor. The historical trend shown in Figure 8.9 suggests that the cost of natural gas is increasing faster than that of coal. One reason is that natural gas is deemed to be a relatively clean and easy fuel that can be distributed continuously on demand without storage bins (in contrast to batches of coal), and because fuel-switching is a highly appreciated way of reducing CO<sub>2</sub> emissions. Another reason is the abundance of coal, which makes coal a more widespread commodity than natural gas, and also because the reserves/production ratio is at least three times higher for coal than that of gas. Hence, as the demand for natural gas is growing, especially in Europe, the price difference is expected to remain and even grow.

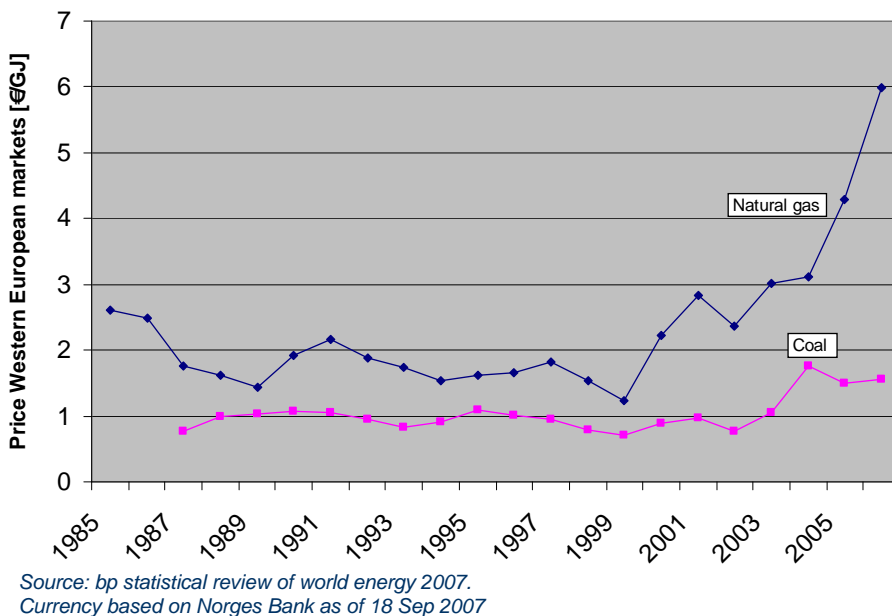

Figure 8.9. Price development of natural gas and coal in Europe.

Furthermore, the size of the plant and the extent of environmental mitigation techniques that is included may have an important role to play. Typically, a large coal power plant may have a price tag of 610 MUSD in short version, as indicated in Figure 8.10. The CoE will then – according to a case study made by the IEA Clean Coal Centre – be around US 4.9 Cents/kWh. By adding flue gas

desulphurization (FGD) the capital expenses may increase to 700 MUSD and the CoE will increase to some 5.4 Cents. Eventually, by adding CCS to this scheme, the investment may reach 1 billion USD, which results in a CoE of 7.5 Cents. This means that the expenses will grow by typically 60% and the CoE will increase by around 50% when shifting from a plain conventional power generation plant to a system with FGD and CCS (in most countries today FGD is mandatory). And, the latter plant version will typically require some 20-30% additional fuel based on a similar energy delivery (i.e. in MWh). Also the cost of technology (investment) is important, as capital expenses will have a profound impact on the generation cost, as shown in Figure 8.11.

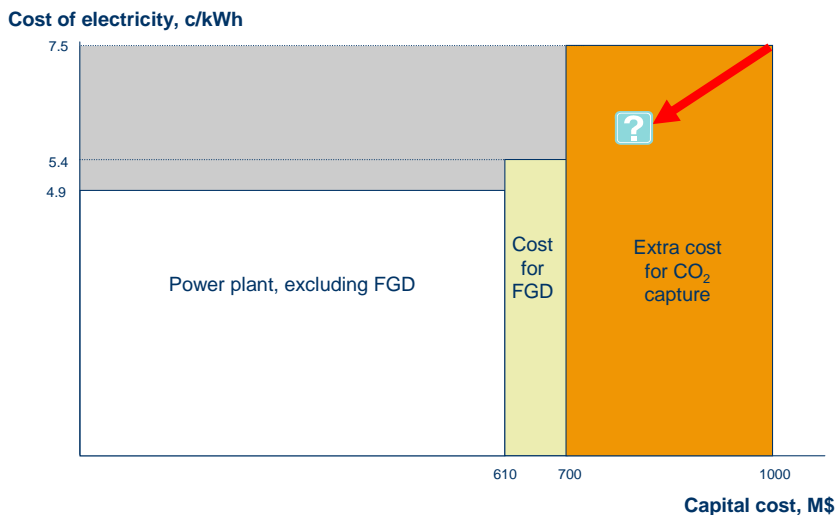

Figure 8.10. Cost of electricity (CoE) versus capital cost of a typical coal-based power generation plant. (Source: IEA Clean Coal Centre)

## 8. Future role for CCS in the Nordic countries

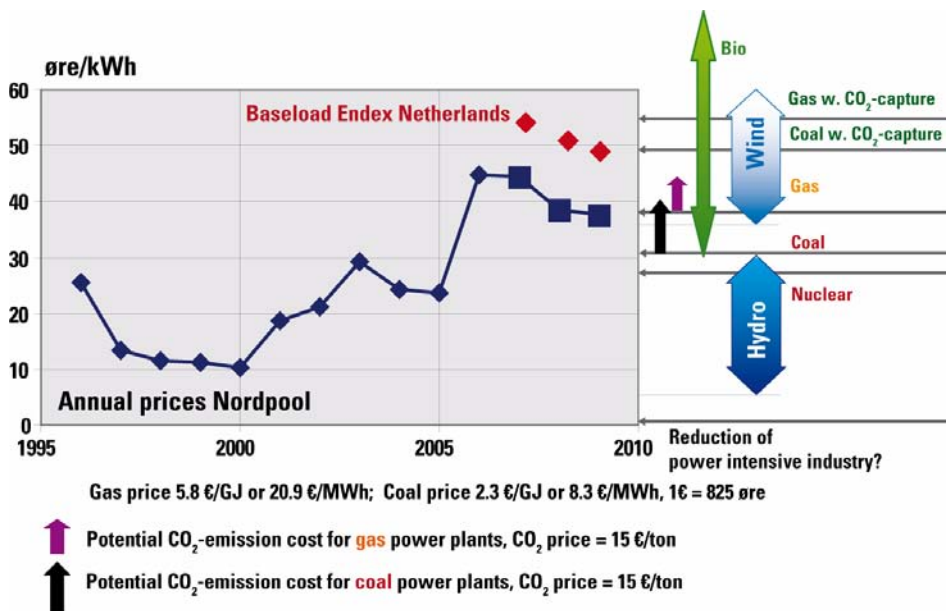

Figure 8.11. Relative generating cost of prevalent energy technologies (Source: SINTEF Energy Research).

### 8.3.2 Impact of carbon tax

A cost comparison made by Deutsche Bank is shown in Table 8.19, in which three thermal power generation plants without CCS have been compared with a coal-based power plant that employs CCS. In the study carbon purchase at a price of 20 €/t CO<sub>2</sub> has been assumed. As seen on the lower yellow line, the price difference – when applying carbon pricing – is fairly not exceedingly high: The difference in CoE between the NGCC and the coal-based CCS plants is only 19%, whereas a shift from conventional coal power to a plant employing CCS would have an impact on the CoE of some 8–16%. This comparison demonstrates the importance of carbon pricing. But, it seems evident that a carbon price of only 20 €/t CO<sub>2</sub> is far too low to justify a transition to CCS. And, it is still believed that carbon pricing alone will not suffice in attracting investors to raise the immense amounts of money that are required for the CCS demonstration projects that are deemed necessary to cut emission by 50–80% by 2050.

Table 8.19. Cost break down and power price of four electric supply options using a carbon pricing of 20€/t CO<sub>2</sub> according to estimates made by Deutsche Bank (2007).

<b>Estimated new-entrant costs for conventional fossil-fuel power plants and CCS with carbon at Euro 20/t</b>				
	Gas plant with 100% carbon purchase	Coal Plant	Lignite plant	CCS
<b>Capital Cost</b>	<b>€63,000/MW</b>	<b>€1,313,000/MW</b>	<b>€1,650,000/MW</b>	<b>€2,222mm</b>
Capacity	1,000 MW	1,000 MW	1,000 MW	800 MW
Capital Outlay	€63	€1,313m	€1,650m	€1,777m
Required return (pre-tax)	9.60%	9.60%	9.60%	9.60%
<b>Fuel Price</b>	<b>€6.2/Gj</b>	<b>€2.23/Gj</b>	<b>€0.7/Gj</b>	<b>€2.23/Gj</b>
Efficiency Rate	57%	47%	45%	35%
	Gas Price €39.2/MWh	Coal Price €17.1/MWh	Lignite Price €6/MWh	Coal Price €2.9/MWh
Fixed operating costs	€12/kw	€45/kw	€45/kw	€60/kw
Variable operating costs	€2.25/MWh	€2.25/MWh	€2.25/MWh	€3/MWh
<b>Carbon Price</b>	<b>€20/tonne</b>	<b>€20/tonne</b>	<b>€20/tonne</b>	
Carbon Intensity	0.365	0.75	0.93	0
Load factor 1 <sup>st</sup> 20 yrs	7.5TWh	7.5TWh	7.5TWh	
Load factor for remaining 20 yrs	40%	40%	40%	
Annual output for remaining 20 years	3.5TWh	3.5TWh	3.5TWh	
<b>Power price needed to earn required return</b>	<b>€57.6/MWh</b>	<b>€63.1/MWh</b>	<b>€58.9/MWh</b>	<b>€68.5MWh</b>

Source: Deutsche Bank 2007

In Figure 8.12 the relative cost allocated to the key steps along the CCS chain is shown. Clearly, capture is the pressing cost aspect, and hence, capture is the most important area to consider for improvements in order to reduce cost. Storage cost, on the other hand, is generally more uncertain, and thereby, important to clarify at an earliest practical stage of any CCS project.

The price level of natural gas power plants in Europe may range from around 580–650 €/kW<sub>e</sub>. Additional cost of the capture train and site-specific infrastructure amounts to 440–490 €/kW<sub>e</sub> (amine scrubbing post combustion) and 145–160 €/kW<sub>e</sub> respectively (Torvanger et al. 2007). This amounts to 1165–1300 €/kW<sub>e</sub> for a complete CCS plant. In Table 8.20, however, under RWE ZEIGCC, a 450 MW<sub>e</sub> plant is assigned a price tag of about 1000 M€ which means 2200 €/kW<sub>e</sub> (Renzenbrink, 2007). This is roughly four times the price level as quoted on conventional power generation technology in China (Hetland et al., 2008a). Furthermore, the price tag of the 500 MW<sub>e</sub> BP-Carson

## 8. Future role for CCS in the Nordic countries

project, as mentioned in the same table, is reported at 800 M€, which means a unit price of 1600 €/per kW<sub>e</sub>.

### Total cost of early commercial projects – reference case

€/tonne CO<sub>2</sub> abated; ranges include on- and offshore

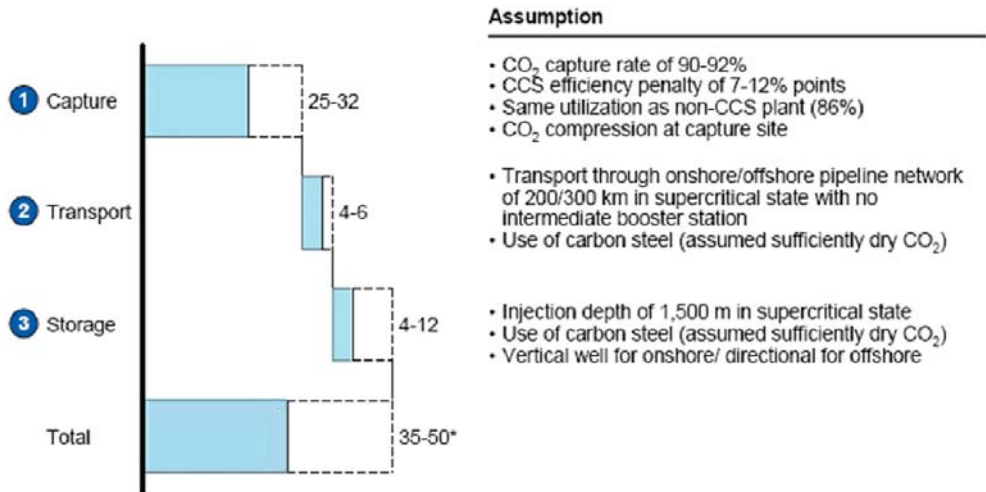

Figure 8.12. Relative cost of CCS and reduction potential according to assessments made by McKinsey (2008).

Table 8.20. Some projects using pre-combustion capture techniques. The budget numbers listed under “status” have been collected by SINTEF from various sources (Hetland et al., 2008a).

Project and operator	Characteristics	Status
BP Miller project Operated by BP (UK) <sup>28</sup> .  Now: Hydrogen Power Abu Dhabi	EOR appears to constitute the main driver of this project, which is about a natural-gas-fired power plant that was planned by BP to be constructed in Scotland. The plant was abandoned due to unresolved policy issues on storage.  The plant that is now being planned for operations in Abu Dhabi employs pre-combustion CCS technology and a net electric capacity of 420 MW. The captured CO <sub>2</sub> will be injected into an oil reservoir (the Miller field (BP, 2005)).	Planned industrial project. Indicative budget 500 M€. Was planned to go on stream by 2010, but has been abandoned in the UK.  The project has been revitalised in Abu Dhabi, and is planned to produce CO <sub>2</sub> for EOR covering a larger oil field cluster.
HÜRTH RWE ZEIGCC Operated by RWE (Germany)	450 MW <sub>e</sub> output, large-scale industrial near zero-emission IGCC plant.	Planned industrial project to go on stream by 2014. Indicative budget: 1000 M€ (Renzenbrink, 2007).
BP-Carson Operated by BP (in the US)	500 MW <sub>e</sub> coal-based power plant considered to be built in the US by BP.	Planned industrial project (considered for early start-up in 2011. Has (reportedly) been put on hold. Indicative budget 800 M€.

### 8.3.3 Cost of CO<sub>2</sub> transport

Millions of tons of CO<sub>2</sub> per year are being piped and tanked over long distances, mainly in the USA. This kind of transport takes place mainly on shore in high pressure pipelines and in sub-sea pipelines for off shore transportation (e.g. Snøhvit project, Norway). The alternative is tanked CO<sub>2</sub> transported by motor carriers, on rails and on board ships.

<sup>28</sup> Refer for instance: <http://www.bp.com/genericarticle.do?categoryId=97&contentId=7006978>

## 8. Future role for CCS in the Nordic countries

Svensson et al. (2004) have summarized the cost results for the transportation alternatives, using a distance of 250 km and a depreciation time of 25 years at 5% interest rate. Results are shown in Figure 8.13.

Motor carriers transportation is mainly used for food-grade CO<sub>2</sub> used in the soft-drink industry and breweries, and the total amount of CO<sub>2</sub> within this sector is less than 100 000 t/a, i.e. much smaller than the amounts associated with CCS. It is suggested that motor carriers are used only when transport load is small – say in the range from 0.1 to 0.2 million tonnes per year. This means that such carriers are not considered for large-scale CCS schemes.

Detailed cost assessment of transport systems must be made on the basis of capacities, distance, materials, geographical constraints and the (possible) need for booster pumps along the pipeline and otherwise on monitoring, as required either for operational purposes or as may become mandatory.

As already presented in section 5.1.3 and section 5.1.4 the following guidelines for pipeline cost at hand are as indicated in Table 8.21.

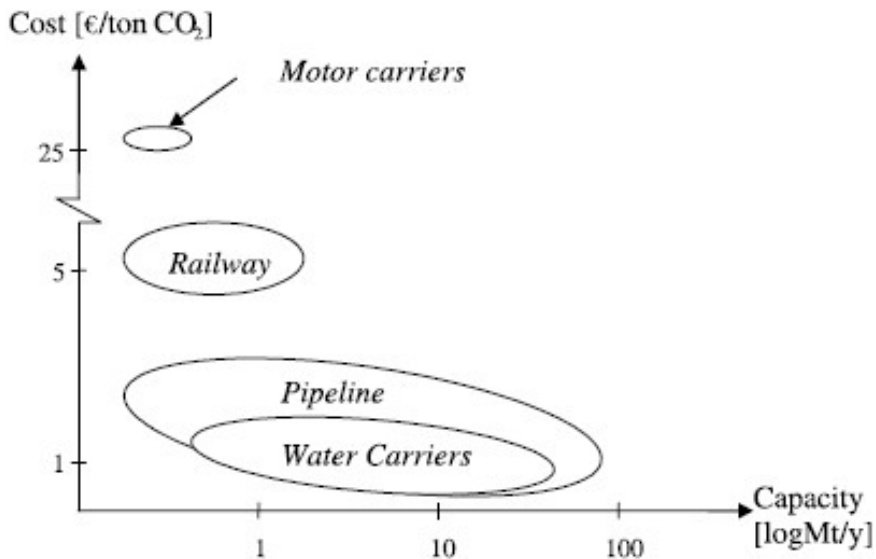

Figure 8.13. Cost and capacity for transportation alternatives at 250 km.



Table 8.21. Pipeline cost as reported from two commercial projects.

Project	Distance [km]	Location	Cost [M€]	Comment
<i>Snøhvit</i>	160	Subsea	125	Localisation factor also higher in Norway than in US/Canada
<i>Weyburn</i>	330	Onshore	75	

As the transportation distances could be substantially longer in the Nordic region than in the above example, certain exigencies would then have to be accounted for both in the cases of pipeline and ship transportation. Increased duration of shipping may cause a need to install a reliquefaction plant on board the water carriers, as some CO<sub>2</sub> needs to be constantly evaporated in order to prevent the temperature and pressure of the cargo from increasing. In case of pipeline transportation, possibly several booster stations need to be constructed in order to keep the pressure of the flowing media well above the saturation line. Lowering both the impurity levels in the transported CO<sub>2</sub> and the velocity of the flow inside the pipeline lowers both the pressure loss and the energy demand of pressurisation, and thus could present one way to decrease the capital and operational costs.

The costs of ship transportation of CO<sub>2</sub> consist of expenses related to the needed number of tankers and terminals, including liquefaction plant, sufficient intermediate storage capacity and on- and off-loading facilities. IPCC has presented estimates for ship prices, based on literary review, ranging from 34 million USD for a 10 000 t carrier to 85 million USD for a 50 000 t carrier (IPCC, 2005). The same report gathered a price for liquefaction plant would amount to 35–80 million USD depending on the liquefaction capacity (from 1 to over 6 Mt/a). For cylindrical steel tanks suitable for on-shore intermediate storage a unit cost of 1 million USD per a tank of 3 000 m<sup>3</sup> has been presented in literature (Aspelund et al., 2009).

## 8.4 Rough scheme for CCS deployment in the Nordic countries

In Finland, Norway, Sweden and Iceland the current largest CO<sub>2</sub> emitting facilities are industrial plants. Only in Denmark the major CO<sub>2</sub> emissions originate from power and heat production. On the other hand, also Finland has several and

## 8. Future role for CCS in the Nordic countries

Sweden has a few power and heat plants emitting 1–2 Mt CO<sub>2</sub>/a, where CCS could be implemented and should be considered as potential candidates for CCS application.

Full and cost effective deployment of CCS in the Nordic countries would require a large scale transport and storage infrastructure including cross-border transport. For the Finnish and Icelandic CO<sub>2</sub> sources, and a large part of the Swedish sources as well, the distance to a mature storage site exceeds 1000 km. For comparison, the existing CO<sub>2</sub> pipelines in USA vary between 130 and 800 km (Chandel et al. 2010). Large pipeline infrastructures that cross international borders are unlikely to occur before 2030 without strong political agreements to tackle climate change and appropriate legislation needed for transferring CO<sub>2</sub> between countries. On the other hand, there is a large uncertainty on the type and location of industrial plants and power plants in the future, which makes detail sketching of a large-scale infrastructure very difficult. Because of the above reasons, we concentrate on rough schemes for a possible infrastructure deployment based on existing CO<sub>2</sub> sources, source clusters and scenario assessments.

It is unlikely, that any CCS plant cluster sharing a common CO<sub>2</sub> transportation pipeline would exist by the year 2020, or during the CCS demonstration phase. Point-to-point pipelines for minimal distances from the CO<sub>2</sub> source to sink and shipping for longer distances would be the most likely options in the first phase of CCS deployment.

After the implementation and operation of CCS demonstration projects, larger networks could become feasible between 2020 and 2030. This statement is supported by our scenario calculations, which show that CCS could play an important role in CO<sub>2</sub> abatement in the Nordic countries. Figure 8.6 represents a scenario with optimistic assumptions on CCS demand (*“high CCS scenario”*) and shows that the overall quantity of CO<sub>2</sub> captured could be around 10–30 Mt CO<sub>2</sub>/a in 2030 in the Nordic countries. At the highest level, it is assumed that also bio-CCS would be technically and economically feasible both in energy conversion and pulp and paper industry. In theory, one to three CCS clusters could be enough to achieve the reduction of around 10–30 Mt CO<sub>2</sub>/a. This indicates that the required infrastructure would still at this stage be very local and site specific. However, it is impossible to indicate, which clusters are the most promising and cost effective, because the realisation of such projects would require a co-operation and financing of several commercial stakeholders, in-depth optimisation of CCS infrastructure, and a co-ordinated activity of authorities.

By the year 2050, the overall quantity of CO<sub>2</sub> captured could be increased to a level of 30-50 Mt CO<sub>2</sub>/a in the *high CCS scenario*. Such quantities would require a well developed Nordic infrastructure for CO<sub>2</sub> transport. In that case, CCS would also need to be implemented in industrial processes (i.e. metal, cement, pulp production), fuel production (oil and gas industry, steam reforming and fisher tropsch synthesis), and large energy plants. However, as already indicated above, there is a list of uncertainties and barriers to overcome before a large scale CCS deployment would be a reality.

Furthermore, as has already been pointed out, CCS is and will remain a policy issue. One important measure therefore is taxation of GHG emissions, of which the impact on generating cost has been assessed based on candidate concepts (most notably NGCC). The outcome of this comparison suggests that even with a carbon tax amounting to (just) 20 €/t CO<sub>2</sub> the additional cost electricity (CoE) generated with a CCS scheme seems to be within reach of what society may be prone to accept. However, according to the modelling results emission allowance costs of up to 90 €/t CO<sub>2</sub> may be required by 2040 to achieve the required large reduction in greenhouse gas emissions.

Finally, as the Nordic countries will be observed like a light-house from abroad, it is important that the Nordic countries leaves a message that is clear and transparent with regards to their issues pertaining to global change and security of energy supply, and that the energy supply in a carbon-constrained future can be deemed efficient in terms of cost and performance.

## 9. Recommendations

The purpose of the current project was to provide specific factual input to improve the understanding of the possibilities for applying CCS in the Nordic countries. The project was requested to deliver a subset of recommendations based on the results from the study with regards to future actions to be pursued under the Top-level research initiative (TRI) on CCS.

### 9.1 Recommendations for actions needed pertaining to timeline, technology priorities and infrastructure deployment

Our scenario calculations show that CCS could play an important role in CO<sub>2</sub> abatement in the Nordic countries in the future. The amount of CO<sub>2</sub> abated by CCS applications in the Nordic countries by 2030 would at most be in the range of 10–30 Mt/a, which would not require any large pipeline infrastructures. Power plants and refineries are the most likely candidates for these early CCS applications. The efficiency of new coal-fired power plants is expected to improve significantly in the near future, owing to new furnace materials that can withstand higher steam parameters than current materials. This will reduce the impact of the efficiency penalty from CCS applications.

By the year 2050, the overall amount of CO<sub>2</sub> captured could be increased to a level of 30–50 Mt CO<sub>2</sub>/a, which would require a well developed Nordic infrastructure for CO<sub>2</sub> transport. In that case, CCS would also need to be implemented in industrial processes, because half of the fossil CO<sub>2</sub> emissions from large point sources come currently from industrial processes. Therefore, it is important for future application of CCS in the Nordic countries that research on CO<sub>2</sub> capture not only focuses on the energy sector but also on application to

large industrial processes, such as steel plants, oil and gas refineries, as well as cement production processes.

### **9.1.1 Typology and priorities of point sources**

Fossil-fired power (and heat) generating plants represents the single largest fossil CO<sub>2</sub> emitting sector in the Nordic countries. Industrial plants, such as steelworks, oil and gas processing, cement plants, pulp and paper plants, generate an equal amount of CO<sub>2</sub> emissions. Hence, existing process technologies in the Nordic countries should be assessed and ranked according to a pre-defined methodology and compared with European standards and otherwise the best practices of the world. This should be made in order to assess the potential impact of a possible modification or replacement with new concepts using benchmarking.

In this manner a short list of technologies should be identified and ranked according to impact of these alternatives on emissions and cost. Crucial is the amount of CO<sub>2</sub> and also the possible access to a suitable transport system in order to divert (efficiently) the CO<sub>2</sub> to a permanent storage site. The CO<sub>2</sub> concentration in the gas stream from which CO<sub>2</sub> is captured is also relevant, as it may affect energy demand and offset the lower heat demand for the capture process (for solvent regeneration) with the higher power demand for the compression train.

In consideration of CCS a suitable typology could be as suggested in Table 9.1.

Table 9.1. Typology definition and priorities (in time).

Technology	Characteristics	Technology	Age	Comments	Timewise priority
Fossil-based power plants		SCPC and USC-PC greenfield and brown-field – the latter for retrofit studies with CCS	New – to be planned. Retrofit – plants newer than 10 years and with a high initial efficiency (at least 44% electric)	Older plants will be phased out, and are prone to have a lousy efficiency than prohibits retrofitting on economic terms.	
Hard coal	> 300 MW				5
Lignite	> 300 MW				5
Natural gas CC	> 300 MW			Owing to the high efficiency the emission index will normally be lower than the proposed level for clean fossil energy (500 g CO <sub>2</sub> per kWh) (ref. Figure 3.11)	2
Simple cycle GT and large reciprocating engines	> 20 MW	Mechanical drives and cogeneration plants with a high operational availability.	Built later than year 2000.	To be considered if the units operate in a cluster that facilitates CO <sub>2</sub> capture and with a short distance to a CO <sub>2</sub> infrastructure.	2

Industrial processing (flue gas) including steelworks, petroleum processing & refineries, cement production, off-shore activities etc.			Any age, however, with a realistic operation horizon of at least 20 years.		
Low CO <sub>2</sub> concentration	< 20%-vol	May use chemical absorption			4
Medium CO <sub>2</sub> concentration	20–50%-vol	May for instance use physical adsorption, or carbonation processes			5
High CO <sub>2</sub> concentration	> 50%-vol	Preferably physical absorption of compression and condensation of water vapour in processes low on nitrogen.			5

### **9.1.2 CCS applications for facilities emitting biogenic CO<sub>2</sub>**

There is clearly a need for supplementary RD&D initiatives to develop knowledge about capture of biogenic CO<sub>2</sub>. Although biogenic CO<sub>2</sub> emissions are not currently part of the EU emission trading scheme, it is possible that this will change in the future, which could motivate the use of CCS for biogenic CO<sub>2</sub> emitting facilities as well.

The results from this study show that far more biogenic CO<sub>2</sub> emissions originate from the pulp and paper industry than from heat and power generation in the Nordic countries. There are also several pulp and paper plants that have annual emissions exceeding 1 Mt biogenic CO<sub>2</sub>, while no heat and power plant has that high emissions (the largest one is currently Avedøreværket in Denmark, with 0.64 Mt biogenic CO<sub>2</sub> emissions in 2007). Therefore, large CO<sub>2</sub> emission reductions could be achieved if CCS was applied in the pulp and paper industry. A large part of these emissions originate from large boilers combusting black liquor, to which CCS could possibly be applied. Studies on how CCS could best be applied to the pulp and paper industry should therefore be encouraged.

### **9.1.3 CCS applications for autonomous offshore power generation**

Autonomous offshore power generation could be specifically addressed under the TRI, as such units may become the early movers. They may burn unprocessed gas, and supply adjacent oil and gas operations with electricity in a hub configuration. And, these units may be placed in the vicinity of the storage site. Surplus power may be exported to shore. It is furthermore believed that the permits of such remote units may be granted more quickly and smoothly than would be the case for similar units on shore.

### **9.1.4 CCS technology development**

Although there is clearly a need for developing CCS technology further to achieve a more cost-efficient CO<sub>2</sub> reduction by CCS, the message from the TRI workshop in Copenhagen on the 2.6.2010 was that no technology development should be funded by the TRI program due to restricted funding resources. Therefore, these recommendations do not include any specific topics for CCS technology development.



## 9.2 Economic and political actions needed for deployment of CCS

### 9.2.1 Policies on future use of fossil fuels and emission reduction commitments

Based on our review of policies for future fossil fuel use and emission reduction commitments in Nordic countries we recommend that the following topics are emphasized in the upcoming TRI research program on CCS:

- *Explore robust policy strategies for CCS development and deployment in Nordic countries* based on scenarios incorporating major uncertain factors such as economic growth and energy demand, price paths of fossil fuels and renewable energy sources, climate policy development, and CCS technology development.
- *How can an efficient CCS supporting framework best be designed?* To what extent should government support CCS directly through funding or other measures, and to what extent base its support indirectly on general policy tools such as carbon tax and GHG emissions trading.
- *Analyze to what degree co-ordinated CCS infrastructure (foremost pipelines) development in Nordic countries will be essential for CCS deployment*, and how in this regard state intervention best should be designed and co-ordinated across countries.

### 9.2.2 EU regulation on CCS and impacts on Nordic countries

We would like to highlight two important topics for future research on the role of European-level policy for development of a CCS system in the Nordic region:

- *What is the need for EU-level coordination and planning with respect to transportation and storage infrastructure?*
  - Are current national and EU level initiatives sufficient to develop the required infrastructure for a major CCS system in the Nordic region on the required timescale?
  - Is improved coordination, planning or regulation from the EU required?

## 9. Recommendations

- Does the need for EU coordination, planning or regulation increase if the geographic scope is extended (to include storage of CO<sub>2</sub> captured in, e.g., the UK, Germany and the Netherlands under the North Sea).
- *Nordic contributions to research, development and demonstration (RD&D).*
  - In what areas do firms based in the Nordic countries have special competence to offer for RD&D into CCS technologies?
  - Is government policy needed to utilize this potential?
  - Relationship between large Norwegian effort emphasizing capture from gas-fired power, and EU-level effort mostly oriented toward coal – is there a good division of labor?

### 9.2.3 Timeline for political processes

A number of uncertain factors make assessment of realistic timelines a challenge. We propose to investigate the “space of possible developments” to get a better grasp of realistic developments of political frameworks for CCS in Nordic countries.

- *Develop scenarios for political CCS strategies and policies in Nordic countries* given outcomes of uncertain external factors such as European and global economic and climate policy developments, and internal factors such as structural economic changes, and changes in political power of various groups, regions and stakeholders.

### 9.2.4 Identification of stakeholders

A better understanding of views and perspectives of major CCS stakeholders is useful to assess possibilities for CCS deployment in Nordic countries.

- *Carry out a survey of main CCS stakeholders in Nordic countries* with respect to their perspectives, expectations and own strategies (confer recommendation a under public awareness.

### 9.3 Recommendations for a Nordic approach regarding public awareness about CCS

The Nordic region offers an intriguing empirical context to develop applicable research from a social science perspective, due to its cultural similarities but significant differences with regards to for example existing energy system and emissions sources. It is imperative to have advanced our knowledge sufficiently on matters such as public opinion in order to be prepared when technical, political and economic preconditions exist. Since public opinion is embedded in a broader set of issues, this type of research is likely to benefit from a large interdisciplinary project in the same geographical region. We propose research in three main areas: “Attitudes”, “Communication” and “Lessons from adjacent fields”.

#### Attitudes towards CCS

- *Nordic overview of current attitudes.* We still do not know what the Nordic population thinks about CCS. Attitude surveys have been a basic study object when considering CCS and it gives an idea about the current public support for CCS. Although such studies have been criticized for methodological shortcomings and limited value, it is a useful platform for the design of more advanced studies which may help us understand underlying factors and benchmark the Nordic region with other countries. Questionnaires should be designed and carried out so that identification of differences in opinion depending on e.g regions and social groups is possible. To complement this work, research on how opinions are formulated and what lies behind certain perceptions should be carried out.
- *Attitudes towards bio-energy CCS.* A peculiar precondition in the Nordic region, especially Sweden and Finland, are the opportunities for bio-energy and CCS. CCS with bio-energy instead of fossil fuels may affect public opinion as it makes the carbon-lock-in-argument irrelevant. This should be part of the survey investigating the Nordic attitudes on CCS.

### Communication on CCS

- *Best practice in communication.* The experiences made by companies and policymakers so far have remained largely unknown to both practitioners and researchers. There is consequently significant potential to learn from experiences and spread best practice.
- *Develop and test information material.* Designing research to develop and test information material on CCS, and study how people respond to it, has been stressed in previous research and offers significant practical value. It could beneficially be combined with the study of opinion formulation.

### Potential in adjacent fields

One way to get a head-start in the Nordic research contribution to this area is to learn from experience made in other fields: for similar empirical issues and adjacent literature.

- *Similar empirical issues.* There may also be important lessons to be drawn from comparable cases, and studies of similar issues, which have created opinion and opposition with reference to risk for human and environmental well-being.
- *Adjacent literature.* Research on public opinion should be synthesized and evaluated in terms of their relevance for CCS. There is also a lot to learn from communication studies. Academia has an edge in this type of work and this type of research could therefore benefit from close university links.

## **9.4 Summary – recommendations for topics in the upcoming research program on CCS**

The duration of the TRI is planned to be five years (i.e. 2011–2015) with a budget allocated for CCS at approximately 40 MNOK (i.e. roughly 8 MNOK per year). Owing to the monetary resources at hand, the TRI will most likely fund studies, rather than research and demonstration.

It is recommended that the TRI should support projects of own merits, however, in a way that may release additional industrial funding (if required). The implication is that TRI funding should (preferably) support actions independent

of specific European public money. This should also apply to specific national public funding provided such financing constitutes a major part of the grants.

As cost constitutes a critical issue, only options for capture, transport and storage that have a fair chance of being accepted should be scrutinised under the TRI programme. Said “fair chance” should be divided into short term (up to 2020), medium term (2020–2030) and long term (beyond 2030). In proposals the notion of “fair chance” should be explicitly justified pursuant to timeline.

Subjects to further investigation under the TRI (summary from the above):

1. Study of options for retrofitting, rebuilding or new installations with CCS, for instance by using the systematic approach presented in Chapter 9.1.1. This could specifically address:
  - The amount of CO<sub>2</sub> from the point sources (identified in this report) pursuant to a stepwise avoidance cost that may be captured and stored in identified sinks as a result of applying CCS
  - Clustering and integration possibilities for application with CCS (including transportation and storage solutions)
  - Viable priority of actions with regards to cost and timeline, starting with the “low-hanging fruits”. This should include closer study of likely candidates for early retrofit with CCS
  - Assessment of environmental impacts of CCS versus cost (both capital investment and operational expenses) based on the presumed retrofit options
  - Case studies for integrating CO<sub>2</sub> capture technologies with combined heat and power plants or industrial processes.
2. Study the possibilities for applying CCS in the pulp and paper industry. This could include:
  - System studies using existing large pulp and paper facilities as examples
  - Technological options for capture, integration possibilities, cost analysis.
3. Analysis of how to deploy CCS in the Nordic countries and how this could be possibly achieved in the time span from 2020 to 2050. This would include assessment of the infrastructural schemes required to meet the targeted needs and complexity thereof as well as the timeline for alternative deployment schemes. The assessment should explore re-

## 9. Recommendations

quired robust policy strategies and how an efficient CCS supporting framework best could be designed. The study could also explore strategies for communication of CCS and take into consideration public awareness and acceptance of CCS.

4. Analysis of the market potentials for CCS technology and related services for the Nordic countries. The study should include an overview of the special competence that companies based in the Nordic countries have to offer for RD&D into CCS technologies. The study should map opportunities in the CCS technology for the Nordic countries, considering the synergical effects of competence and resources of the various Nordic countries.
5. Studies on geological storage (including EOR and EGR) in the Nordic countries and neighboring areas should be encouraged, but must be based on publicly available information. These will mainly be limited to capacity, injectivity and location. Only potential structures that are pre-considered as being reasonably suitable for underground CO<sub>2</sub> storage should be considered under the TRI initiative.
6. Study the possibilities for applying CCS at autonomous offshore power generation.
7. Study on the public awareness of CCS in the Nordic countries. This would include a survey of current attitudes in the Nordic countries. The study could also assess how opinions regarding CCS have been formulated and what lies behind certain perceptions. Attitudes towards bio-CCS should also be investigated by the survey. The study should also include a best practice overview on communication of CCS. Informational material on CCS could possibly also be designed and tested.

## 10. Summary

Carbon capture and storage (CCS) is considered to be one of the main methods for reducing carbon dioxide emissions. Other methods are more effective energy use, improved energy conversion technologies, a shift to low-carbon or renewable biomass fuels, a shift to nuclear power, improved energy management, the reduction of industrial by-product and process gas emissions. In order to stabilise the global temperature rise to 2°C over the pre-industrial level, a 50–85% reduction of greenhouse gas emissions from the present level is needed, which will require all of the measures mentioned above. Much effort is therefore put into the development of CCS in order to have the technology ready for large scale deployment in the upcoming decades.

CCS could prove opportunities for the Nordic countries, since both large stationary sources of CO<sub>2</sub> and geology suitable for storage of CO<sub>2</sub> can be found in this region. This study was made for providing an overview of the potential for applying CCS in the Nordic countries. The study gives an overview of the technologies and applications required for CCS in the Nordic countries, as well as the current energy policies and status on public awareness of CCS in the Nordic countries. Large emission sources in each Nordic country have been mapped in detail and potential storage sites have been listed. An overview of current CCS projects has also been given. The future potential for CCS in the Nordic countries has been evaluated using scenario analysis and a regional assessment over the possibilities for CCS application has been given. As an outcome of the study a set of recommendations has been made for topics that could be supported by the upcoming Nordic Top-level research initiative on CCS.

A database over the largest CO<sub>2</sub> emitting facilities in the Nordic countries was made, which includes both biogenic and fossil or mineral CO<sub>2</sub> emissions from facilities emitting annually over 0.1 Mt CO<sub>2</sub> (data for year 2007 used). In total, 277 facilities exceeded that emission level in 2007. The total sum of the fossil

emissions from these facilities was 113 Mt CO<sub>2</sub>, which corresponds to 51% of the total (fossil) CO<sub>2</sub> emissions from the Nordic countries that year. Only 31 of the 277 facilities had CO<sub>2</sub> emissions exceeding 1.0 Mt fossil CO<sub>2</sub>. The total amount of fossil CO<sub>2</sub> emissions from these facilities amounted to 57 Mt or 26% of the total (fossil) CO<sub>2</sub> emissions from the Nordic countries that year. Power and heat plants accounted for the largest part (45%) of the fossil CO<sub>2</sub> emissions in the database, and most of these plants were located in Finland and Denmark. Oil and gas activities accounted for the second largest share of the emissions (22%), with refinery emissions in all countries (except Iceland) and most of the offshore activities in Norway. Iron and steel production was the third largest sector, of which most plants were located in Finland and Sweden. The database has been used for constructing maps that show the location and types of CO<sub>2</sub> emitting facilities as well as the magnitude of annual CO<sub>2</sub> emissions.

Most of the research and development work on CCS technologies has so far been concentrated on solutions for power plants. Three main technological methods are closest to commercialisation: post-combustion capture, pre-combustion capture, and oxy-fuel combustion capture. Applying CCS technology to power plants would reduce the CO<sub>2</sub> emissions from combustion with 80-90%, but it would also almost double the production cost of electricity and requires more fuel to supply energy for the capture process using current technologies. As CCS has not yet been applied to full extent at a large-scale fossil-fuel power plant the cost estimations of CCS still have large uncertainties. The main challenge for the development of CO<sub>2</sub> capture technology is to reduce the energy requirements of the capture processes, because the largest part of the costs of CCS projects comes from CO<sub>2</sub> capture. New materials for steam boilers are being developed that can withstand higher steam parameters. This will lead to larger efficiencies in new power plants, which in turn will make energy requirements of the capture processes more manageable. A large part of the CO<sub>2</sub> emissions in the Nordic countries come from large coal-fired combined heat and power (CHP) plants. However, current research and development has focused more on capture from condensing coal-fired power plants, both in the Nordic countries and internationally.

Industrial facilities, such as steel plants, oil and gas refineries and platforms, as well as cement manufacturing plants are also important large sources of CO<sub>2</sub> emissions, and therefore CCS solutions for these processes are also being developed. Three of the four operational large-scale CCS projects capture CO<sub>2</sub> from natural gas processing. Of these, two are situated offshore Norway: the Sleipner



and Snøhvit projects. Several projects for demonstrating CCS technology are also being planned in the Nordic countries, of which the most significant are the projects at the Nordjylland and Meri-Pori power stations as well as the retrofit of the Mongstad refinery. The timeline for deployment of CCS in the Nordic countries is likely to depend much on the success of these projects.

At the end of the CCS chain the CO<sub>2</sub> needs to be stored safely for several thousand years in isolation from the atmosphere. Currently, the only feasible technology for accomplishing storage on a sufficiently large scale is the use of underground geological formations for the storage of CO<sub>2</sub>, such as deep saline aquifers as well as depleted or nearly depleted oil and gas fields. These are available in the Nordic region, mainly offshore Norway and Denmark, but also onshore Denmark and offshore Sweden. The injection of CO<sub>2</sub> into geological formations involves many of the same technologies that have been developed in the oil and gas exploration and production industry. In this study, the maturity of the geological formations in the Nordic countries was assessed and the capacity estimates reviewed. The mature offshore aquifer storage capacity in Norway was estimated to 84.6 Gt CO<sub>2</sub>, with a maximum injection rate of 254 Mt/a. The mature onshore and offshore aquifer storage capacity in Denmark was estimated to 1.7 Gt CO<sub>2</sub>. The south-western and south-eastern sea areas of Sweden have also favourable geological formations, but significant exploration in this region is needed before storage estimates can be provided. In Finland, the bedrock is not suitable for geological storage of CO<sub>2</sub>. Instead, the high availability of magnesium silicate rock has motivated research on methods for storage of CO<sub>2</sub> as magnesium carbonate. Binding the CO<sub>2</sub> with silicate minerals into solid carbonates is technically possible, but current state-of-the-art processes have large energy requirements, which make them unsuitable for CCS purposes. Also, carbonation of magnesium silicates for CCS purposes would probably demand additional mining operations of similar size as current national mining operations in the Nordic countries. In Iceland, the bedrock consists mostly of reactive basalt. Injection of CO<sub>2</sub> into the porous, underground basaltic rock formations could be an interesting domestic option for CO<sub>2</sub> storage in Iceland. The method is currently being studied in Iceland, but the feasibility of the concept as a practical storage option is far from being established at the present.

The Nordic countries aim more at decarbonizing their economies in a long-term perspective. This would require a high price tag on greenhouse gas (GHG) emissions and most likely application of CCS. With a 2020 time horizon most Nordic countries have quantified targets to reduce GHG emissions, mainly

through increased deployment of renewable energy and energy efficiency measures supported by GHG pricing with the help of emissions trading and carbon taxes. The EU regulation on CCS will impact on the conditions for CCS in the Nordic region. EU has launched the CCS directive and has committed to fund several CCS demonstration projects in the near future. So far, there has been little coordinated European activity related to CCS infrastructure development. Also, policies related to CCS are still at an early stage in the Nordic countries. It is therefore questionable whether the current national and EU level initiatives are sufficient to develop the required infrastructure for CCS deployment in the Nordic region on the required timescale.

The public opinion of carbon capture and storage (CCS) has repeatedly been emphasized as an essential factor to realize large-scale development and deployment of the technology. Many CCS projects in Europe and US have already faced local opposition that has delayed or undermined projects, which may be a result from the fact that very few people are familiar with CCS. The communication of CCS provides an opportunity to not only inform the public about ongoing plans, but it also contributes to evolving perceptions among the general public and an increased understanding of the issue. So far, no overview on the public awareness in the Nordic countries has been made.

The role of CCS in the Nordic countries in the future was studied using a Nordic TIMES energy system model and complemented by studying regional options for CCS application to existing facilities. The scenarios created with the model indicate that a GHG reduction of 75–80% in the Nordic countries by 2050 could be technically possible. This would, however, require that the price of the emission allowances would rise from 10 €/t in 2010 to 100 €/t CO<sub>2</sub> by 2050. In the scenario assuming the most optimistic conditions for CCS, the total quantity of CO<sub>2</sub> captured in the Nordic countries was 10–30 Mt CO<sub>2</sub>/a in 2030 and 30–50 Mt CO<sub>2</sub>/a by 2050.

The maps created based on the CO<sub>2</sub> emission database reveal several potential clusters of CO<sub>2</sub> emitting facilities that could be possible candidates for CCS application. Most of the largest emission sources are located along the coast lines of the Nordic countries and have harbour access, which facilitates transportation of CO<sub>2</sub> by ship. In the early stages of CCS deployment ship transportation is likely to be dominating until a pipeline infrastructure has been built. Likely candidates for CCS applications are large coal-fired power plants in Denmark and natural gas refineries in Norway, since these are among the largest point sources of CO<sub>2</sub> in the Nordic countries and are located close to mature storage

sites. Refineries additionally benefit from existing pipeline routes to mature storage sites and existing experience with gas processing. Offshore platforms in the North Sea and the Norwegian Sea stand for a significant part of the point sources of CO<sub>2</sub> and have the benefit of being located in the same region as mature storage sites. However, the challenges for offshore application are many, including limited space and multiple CO<sub>2</sub> sources per platform. The large steel plants in Finland and Sweden are also attractive for CCS application, but may be restricted by the large shipping distances to mature storage sites. In general, retrofit of old facilities with CCS is costly and difficult in many cases, which in practice will limit the application of CCS to existing facilities.

The total sum of the biogenic emissions from the facilities in the database was found to be 54 Mt CO<sub>2</sub> in 2007, which is a considerable amount. Most of these emissions (76%) originate from large pulp and paper factories in Finland and Sweden, while the rest originated mostly from co-firing of biomass in power and heat plants in Finland, Sweden and Denmark. Since the current EU Emission Trading Scheme (ETS) for CO<sub>2</sub> emissions does not include CO<sub>2</sub> originating from biomass, there are currently no economic incentives for applying CCS to facilities emitting biogenic CO<sub>2</sub>, although CCS applied to biogenic emissions would turn the facility into a CO<sub>2</sub> sink, if we use the emission calculation rules by UNFCCC. Also, very few studies have been performed on this topic.

Since most of the known and mature storage potential in the Nordic countries is located in the North Sea, full and cost effective deployment of CCS in the Nordic countries would require a large-scale transport and storage infrastructure including cross-border transport. This would require co-operation and financing of several commercial stakeholders, in-depth optimisation of CCS infrastructure, and a co-ordinated activity of authorities. Large pipeline infrastructures that cross international borders are unlikely to occur before 2030 without strong political agreements to tackle climate change and appropriate legislation needed for transferring CO<sub>2</sub> between countries. On the other hand, there is a large uncertainty on the type and location of industrial plants and power plants in the future, which makes detail sketching of a large-scale infrastructure very difficult. According to the scenarios, the overall quantity of CO<sub>2</sub> captured could be increased to a level of 30–50 Mt CO<sub>2</sub>/a by 2050. However, this would require CCS to be implemented except in power plants also in industrial processes and fuel production.

Based on this study, a set of recommendations for topics that could be studied in the Nordic Top-level research initiative on CCS have been laid out. These

## 10. Summary

include evaluation of existing facilities for to their suitability for CCS application, CCS applications for the pulp and paper industry, requirements for ramping up the deployment of CCS, geological storage assessments, analysis of CCS technology market potential, identification of joint CCS demonstration projects, and an overview of the public awareness on CCS in the Nordic countries.

## References

- Aatos, S., Sorjonen-Ward, P., Kontinen, A., Kuivasaari, T. 2006. Serpentiinin ja serpentiinin hyötykäyttönäkymiä (Outlooks for utilisation of serpentine and serpentine). Geological Survey of Finland (GSF), Report No. M10.1/2006/3, Kuopio, Finland. (In Finnish)
- Aftenposten, 2010. Her er Norges CO<sub>2</sub>-verstinger. Published 20 May 2010. <http://www.aftenposten.no/klima/article3658739.ece>
- Alfredsson, H.A., Hardarson, B.S., Franzson, H. and Gislason, S. R. 2008. CO<sub>2</sub> sequestration in basaltic rock at the Hellisheidi site in SW. *Mineralogical Magazine*, February 2008, Vol. 72(1), pp. 1–5.
- Ashworth, P. et al. 2010. From research to action: Now we have to move on CCS communication. *International Journal of Greenhouse Gas Control*, Vol 4, pp. 426–433.
- Aspelund, A. and Jordal, K. 2007. Gas conditioning – The interface between CO<sub>2</sub> capture and transport. *International Journal of Greenhouse Gas Control*, doi:10.1016/S1750-5836(07)00040-0.
- Aspelund, A., Tveit, S.P. and Gundersen, T. 2009. A liquefied energy chain for transport and utilization of natural gas for power production with CO<sub>2</sub> capture and storage – Part 3: The combined carrier and onshore storage. *Applied Energy* 86(6), pp. 805-814. DOI: 10.1016/j.apenergy.2008.10.023.
- Bachu, S., Bonijoly, D., Bradshaw, J., Burruss, R., Christensen, N.P., Holloway, S. and Mathiassen, O.-M. 2007. Estimation of CO<sub>2</sub> Storage Capacity in Geological Media, Phase 2. Carbon Sequestration Leadership Forum, Technical Group, Task Force on CO<sub>2</sub> Storage Capacity Estimation.
- Bessette, J. 1980. *Deliberative Democracy: The Majority Principle in Republican Government*. In: *How Democratic is the Constitution?* Washington, D.C., AEI Press. Pp. 102–116.
- Bøe, R., Magnus, C., Osmundsen, P.T. and Rindstad, B.I. 2002. CO<sub>2</sub> point sources and subsurface storage capacities for CO<sub>2</sub> in aquifers in Norway. NGU Report 2002.010, 132 pp. [http://www.ngu.no/FileArchive/101/2002\\_010\\_skjerm.pdf](http://www.ngu.no/FileArchive/101/2002_010_skjerm.pdf)
- BP, 2005. Introducing hydrogen power. BP's plan to generate electricity from hydrogen and capture carbon dioxide could set a new standard for cleaner energy. Web

page, <http://www.bp.com/genericarticle.do?categoryId=97&contentId=7006978>  
(web-site last visited 24 March 2007)

Chandel, M.K., Pratson, L.F. and Williams, E. 2010. Potential economies of scale in CO<sub>2</sub> transport through use of a trunk pipeline. *Energy Convers Manage*, 51(12), pp. 2825–2834.

Curry, T., Reiner, D., Ansolabehere, S. and Herzog, H. 2004. How aware is the public of carbon capture and storage? In: Rubin, E., Keith, D. and Gilboy, C. (eds.) *Proceedings of 7th International Conference on Greenhouse Gas Control Technologies*. Volume 1: Peer-Reviewed Papers and Plenary Presentations, IEA Greenhouse Gas Programme, Cheltenham, UK.

Daamen, D. et al. 2006. Pseudo-opinions on CCS technologies, 8th International Conference on Greenhouse Gas Control Technologies (GHGT-8), June 22, 2006, Trondheim, Norway.

de Best-Waldhober, M., Daamen, D., Ramirez Ramirez, A., Faaijb, A., Hendriks, C. and de Visser, E. 2009. Informed public opinions on CCS in comparison to other mitigation options. *Energy Procedia* 1, pp. 4795–4802.

de Best-Waldhober, M. & Daamen, D. 2006. Public perceptions and preferences regarding large scale implementation of six CO<sub>2</sub> capture and storage technologies. Well-informed and well-considered opinions versus uninformed pseudo-opinions of the Dutch public, NWO/SenterNovem Project: Transition to sustainable use of fossil fuel. March 2006, Retreivable at <http://www.chem.uu.nl/nws/www/publica/publicaties2006/E2006-43.pdf>

de Visser, E., Hendriks, C., Barrio, M., MølInvik, M.J., de Koeijer, G., Liljemark, S. and Le Gallo, Y. 2008. DYNAMIS CO<sub>2</sub> quality recommendations, *International Journal of Greenhouse gas Control* 2, pp. 478–484.

EC, 2009. Directive 2009/31/EC of the European Parliament and of the Council on the geological storage of carbon dioxide. *Official Journal of the European Union*, L140/114-135. <http://eur-lex.europa.eu/LexUriServ/LexUriServ.do?uri=OJ:L:2009:140:0114:0135:EN:PDF>

EC, 2009. Methodology for the free allocation of emission allowances in the EU ETS post 2012 – Sector report for the aluminium industry. Ecofys (project leader), Fraunhofer Institute for Systems and Innovation Research, Öko-Institut. By order of the European Commission, contract 07.0307/2008/515770/ETU/C2. <http://ec.europa.eu/environment/climat/emission/pdf/bm/BM%20study%20-%20Aluminium.pdf>

- European Commission 2009. Europeans' attitudes towards climate change, Special Eurobarometer 322, Conducted by TNS Opinion & Social at the request of Directorate General Communication Survey co-ordinated by Directorate General Communication.
- Fagerlund, J., Nduagu, E., Romão, I. and Zevenhoven, R. 2010. CO<sub>2</sub> fixation using magnesium silicate minerals. Part 1: Process description and performance. Proceedings of ECOS2010, Lausanne, Switzerland, June 14–17, 2010.
- FINNCAP, 2010. FINNCAP – Meri-Pori CCS project. Web page. <http://www.finncap.fi/>
- Fischedick, M. et al. 2009. Stakeholder acceptance of carbon capture and storage in Germany. *Energy Procedia*. Vol 1, pp. 4783–4787.
- GeoCapacity, 2009. EU GeoCapacity – Assessing European Capacity for Geological Storage of Carbon Dioxide. D42 GeoCapacity Final Report. <http://www.geology.cz/geocapacity/publications>
- Gerdemann, S.J., O'Connor, W.K., Dahlin, D.C., Penner, L.R. and Rush, H. 2007. Ex Situ Aqueous Mineral Carbonation. *Environ. Sci. Technol.* 41, pp. 2587–2593.
- Gode, J. and Hagberg, L. 2008. Systemanalys av CCS vid kraftvärme. IVL Rapport B1870. <http://www3.ivl.se/rapporter/pdf/B1870.pdf>
- Gough, C. 2008. State of the Art in carbon dioxide capture and storage in the UK – An experts' review. *International Journal of Greenhouse Gas Control*. Vol. 2, No. 1, pp. 155–168.
- Hammerfest Energi AS. 2010. Hammerfest Gasskraft web pages. <http://www.hammerfestenergi.no> (2010-08-11).
- Hammerfest Gasskraft. 2010. Official web site. <http://www.gasskraft.com> (2010-08-11).
- Hetland, J., Kvamsdal, H., Haugen, G., Major, F., Kårstad, V. and Tjellander, G. 2009. Integrating a full carbon capture scheme onto a 450 MWe NGCC electric power generation hub for offshore operations: Presenting the Sevan GTW concept. *Applied Energy*, Vol. 86, Issue 11, pp. 2298–2307.
- Hetland, J., Li, Z. and Xu, S. 2008a. How polygeneration schemes may develop under an advanced clean fossil fuel strategy under a joint Sino-European initiative. *Springer Clean Technologies and Environmental Policy* (128).

- Hetland, J., Røkke, N.A., Røkke, P., LeGallo, Y., Evans, D.J. and Eickhoff, C. 2008b. Towards large-scale co-production of electricity and hydrogen via decarbonisation of fossil fuels combined with CCS (geological storage). Proceedings of GHGT-9 in Washington D.C., USA, 17–20 November 2008.
- Holloway, S., Bateman, K., Barbier, J., Doherty, P., Fabriol, H., Harrison, R., Heederik, J.P., van der Meer, L.G.H., Czernichowski-Lauriol, I., Lindeberg, E.G.B, Pearce, J.M., Summerfield, I.R., Rochelle, C., Sanjuan, B., Schartzkopf, T., Kaarstad, O. and Berger, B. 1996. The Underground Disposal of Carbon Dioxide. Final Report of JOULE II Project no. CT92-0031, Non Nuclear Energy R&D Programme.
- Huijts, M. A. et al. 2007. Social acceptance of carbon dioxide storage. *Energy Policy*, Vol. 35, No. 5, pp. 2780–2789.
- IEA GHG 2007. CO<sub>2</sub> Capture Ready Plants, Technical Study, Report No. 4, OECD/IEA 2008, 117 p.
- IEA 2008. CO<sub>2</sub> capture and storage – A key carbon abatement option. International Energy Agency, OECD/IEA 2008, 261 p.
- IEA 2009a. CO<sub>2</sub> emissions from fossil fuel combustion – Highlights, 2009 edition. International Energy Agency, OECD/IEA 2009, 124 p.
- IEA 2009b. World Energy Statistics 2009. International Energy Agency, OECD/IEA 2009. CD-ROM.
- IEA 2010a. Carbon Capture and Storage – Progress and Next Steps. IEA/CSLF Report to the Meskoka 2010 G8 summit. International Energy Agency. OECD/IEA 2010, 44 p.
- IEA 2010b. World Energy Statistics 2009. International Energy Agency, OECD/IEA 2010. CD-ROM.
- IPCC 2005. Carbon Dioxide Capture and Storage. IPCC Special Report on Carbon Dioxide Capture and Storage. Prepared by the Working Group III of the Intergovernmental Panel on Climate Change, Cambridge University Press, Cambridge (USA).
- IPCC 2007. Climate Change 2007: The Physical Science Basis. Contribution of Working Group I to the Fourth Assessment Report of the Intergovernmental Panel on Climate Change. Solomon, S., Qin, D., Manning, M., Chen, Z., Marquis, M. Averyt, K.B., Tignor, M. and Miller, H.L. (Eds.). Cambridge University Press, Cambridge, United Kingdom and New York, NY, USA.



- Isohanni, M., Ohenoja, V. and Papunen, H. 1985. Geology and nickel-copper ores of the Nivala area. Geological Survey of Finland, Bulletin, 333, pp. 211–228.
- Kelemen, P.B., Matter, J. and Streit, L. 2008. Field observations and theoretical studies relevant to enhanced *in situ* carbonation of peridotite. In: Proceedings of the 2<sup>nd</sup> International Conference on Accelerated Carbonation of Environmental and Materials Engineering, October 1–3 2008, Rome, Italy, pp. 105–111.
- Kilpilahti, 2010. Web page about the industrial cluster in Kilpilahti. <http://www.kilpilahti.fi/>
- Kloster, P. 2000. Reduction of emissions to air through energy optimization on offshore installations. Society of Petroleum Engineers Inc.
- Kogel, J.E., Trivedi, N.C., Barker, J.M. and Krukowski, S.T. (eds.). 2006. Industrial minerals & rocks: commodities, markets, and uses (7<sup>th</sup> ed.). Society for Mining, Metallurgy, and Exploration (U.S.). ISBN: 978-0-87335-233-8. 1528 p.
- Kvamsdal, H., Hetland, J., Haugen, G., Svendsen, H.F., Major, F., Kårstad, V. and Tjellander, G. 2010. Maintaining a neutral water balance in a 450 MWE NGCC-CCS power system with post-combustion dioxide capture aimed at offshore operation, International Journal of Greenhouse Gas, doi:10.1016/j.ijggc.2010.01.002
- Lackner, K.S. 2003. A guide to CO<sub>2</sub> sequestration. Science, 300, pp. 1677–1678.
- Lindeberg, E., Vuillaume, J.-F. and Ghaderi, A. 2009. Determination of the CO<sub>2</sub> storage capacity of the Utsira formation Original Research Article. Energy Procedia, 1(1), pp. 2777–2784.
- Malone, E. L. et al. 2010. Moving from misinformation derived from public attitude surveys on carbon dioxide capture and storage towards realistic stakeholder involvement. International Journal of Greenhouse Gas Control, Vol. 4, Issue 2, March 2010, pp. 419–425.
- Matter, J.M., Broecker, W.S., Stute, M., Gislason, S.R., Oelkers, E.H., Stefánsson, A., Wolff-Boenisch, D., Gunnlaugsson, E., Axelsson, G. and Björnsson, G. 2009. Permanent Carbon Dioxide Storage into Basalt: The CarbFix Pilot Project, Iceland. Energy Procedia 1(1), pp. 3641–3646.
- Meadowcroft, J. and Langhelle, O. (Eds.) 2009. Caching the Carbon: The Politics and Policy of Carbon Capture and Storage. Edward Elgar, Cheltenham, UK.
- Miller, E., Bell, L. and Buys, L. 2007. Public Understanding of Carbon Sequestration in Australia – Socio-Demographic Predictors of Knowledge, Engagement and Trust. Australian Journal of Emerging Technologies and Society, Vol. 5, pp. 15–33.

- Ministry for the Environment, Iceland 2009. Iceland's fifth National communication on climate change under the UNFCCC, December.
- Ministry of the Environment, Sweden 2009. Sweden's fifth national communication on climate change under the UNFCCC, December.
- Ministry of Climate and Energy, Denmark 2009. Denmark's fifth national communication on climate change, December.
- Ministry of Environment, Finland 2009. Finland's fifth national communication under the UNFCCC on climate change, December.
- Ministry of Employment and Economy, Finland 2009. Energy demand by 2030. Scenarios for electricity and energy consumption 10.11.2009. (In Finnish) [http://www.tem.fi/files/25135/Energian\\_kysynta\\_vuoteen\\_2030\\_Arvioita\\_sahkon\\_ja\\_energian\\_kulutuksesta\\_TEM\\_EOS\\_10.11.2009.pdf](http://www.tem.fi/files/25135/Energian_kysynta_vuoteen_2030_Arvioita_sahkon_ja_energian_kulutuksesta_TEM_EOS_10.11.2009.pdf)
- NGU, 2009. Mineral resources in Norway 2008. Production data and annual report. Norges geologiske undersøkelse (NGU). [http://www.ngu.no/en-gb/hm/Publications/Reports/2009/Mineral\\_Resources\\_Norway/](http://www.ngu.no/en-gb/hm/Publications/Reports/2009/Mineral_Resources_Norway/)
- Offshore & Energy. Høyre etterlyser CO<sub>2</sub>-fangst på Kårstø. Published 4 May 2010. <http://www.offshore.no/nyheter/sak.aspx?id=29046>
- Oltra, C. et al. 2010. Lay perceptions of carbon capture and storage technology, International Journal of Greenhouse Gas Control, in press.
- Orkuveita Reykjavíkur. 2010. Hellisheiði Geothermal Plant. Date of citation 28 June 2010. Available at: <http://www.or.is/english/projects/hellisheidigeothermalplant/>
- Otter, N. 2010. The importance of Advanced Material in achieving the goals of other ETPs. Zero Emission Fossil Fuel Power Plant Platform (ZEP), [http://eumat.eu-vri.eu/downloads/Launchevent/transparencies/11\\_ZEFFPP-EuMaTv2.pdf](http://eumat.eu-vri.eu/downloads/Launchevent/transparencies/11_ZEFFPP-EuMaTv2.pdf) (last visited April 2010)
- Outokumpu, 2008. Outokumpu to double ferrochrome production capacity in Finland. Press release. [http://www.outokumpu.com/pages/XMLPage\\_\\_\\_\\_8941.aspx?xmlurl=http://cws.huginonline.com/O/3010/PR/200806/1224586.xml&type=1](http://www.outokumpu.com/pages/XMLPage____8941.aspx?xmlurl=http://cws.huginonline.com/O/3010/PR/200806/1224586.xml&type=1)
- Pelham, B. 2009. Awareness, Opinions about Global Warming Vary World-Wide, Published April 22, 2009 and retrieved at June 17, 2010 from Gallup's website: <http://www.gallup.com/poll/117772/Awareness-Opinions-Global-Warming-Vary-Worldwide.aspx#2>

- Pietzner, K., Schumann, D., Tvedt, S., Torvatn, H., Næss, R., Reiner, D., Anghel, S., Cismaru, D., Constantin, C., Daamen, D., Dudu, A., Esken, A., Gemeni, V., Ivan, L., Koukouzas, N., Kristiansen, G., Markos, A., Mors, E., Nihfidov, O., Papadimitriou, J., Samoila, I., Sava, C., Terwel, B., Tomescu, C., and Ziogou, F. 2010. Scrutinizing the impact of CCS communication on the general and local public: Results of the representative national surveys of public awareness, knowledge and opinions concerning CCS, Report from the FENCO-ERA research project.
- Reiner, D. 2008. A looming rhetorical gap: A survey of public communications activities for carbon dioxide capture and storage technologies. <http://www.eprg.group.cam.ac.uk/wp-content/uploads/2008/11/eprg08011.pdf> (2010-05-26).
- Reistad, A. 2010. Daglig leder/Director, Industrikraft Møre. Phone conversation 10 August 2010.
- Renzenbrink, W. Future Power Generation Concepts: In which direction is Europe prone to go? Case study presented at Synergies between HYPOGEN and the Hydrogen Economy Expert Workshop in Brussels 18th January 2007.
- Rundberg, Y. and Eidvin, T. 2005. Controls on depositional history and architecture of the Oligocene-Miocene succession, northern North Sea Basin. In: Wandaas, B.T.G. et al. (eds.) Onshore-Offshore Relationships on the North Atlantic Margin. NPF Special Publication 12, pp. 207–239.
- Scandinavian mineral gallery, 2010. webpage: <http://www.geology.neab.net/minerals/serpenti.htm> [Accessed 17.5.2010].
- SFT, 2010. Norske utslipp – landbasert industri – CO<sub>2</sub> – utslipp per bedrift 2007–2008. <http://www.norskeutslipp.no/Templates/NorskeUtslipp/Pages/component.aspx?id=51&epslanguage=no&ComponentType=utslipp&ComponentPageID=51>
- SGU, 2009. Statistics of the Swedish Mining Industry 2008. [http://www.sgu.se/sgu/sv/produkter-tjanster/produkter/sgu\\_publ/publ\\_beskr/perpubl\\_2009-1.html](http://www.sgu.se/sgu/sv/produkter-tjanster/produkter/sgu_publ/publ_beskr/perpubl_2009-1.html)
- Shackley, S. et al. (2007) Stakeholder perceptions of CO<sub>2</sub>-capture and storage in Europe – Results from a survey, *Energy Policy*, Vol. 35, No. 10, pp. 5091–5108.
- Sipilä, J., Teir, S. and Zevenhoven, R. 2008. Carbon dioxide sequestration by mineral carbonation – Literature review update 2005–2007. Report VT 2008-1, Åbo Akademi University, Faculty of Technology, Heat Engineering Laboratory.
- Skagerak Energi AS. 2009. Fakta om gasskraftverket på Herøya.

- [http://www.skageraknett.no/eway/default.aspx?pid=300&trg=MainRight\\_9401&MainArea\\_8872=9401:0:&MainRight\\_9401=9404:49751::0:9405:7::0:0](http://www.skageraknett.no/eway/default.aspx?pid=300&trg=MainRight_9401&MainArea_8872=9401:0:&MainRight_9401=9404:49751::0:9405:7::0:0). (2010-07-01).
- Sonck, N. and Loosveldt, G. 2010. Impact of Poll Results on Personal Opinions and Perceptions of Collective Opinion. *International Journal of Public Opinion Research*, 22(2), pp. 230–255.
- Statoil. 2010. Official web site. <http://www.statoil.com> (2010-07-01).
- Steinsvik, O. 2010. <http://www.steinsvikolivin.no/hXGZyUgJLO3U.10.idium> [Accessed 17.5.2010].
- Svenska Dagbladet 2010. Alliansen öppnar för lagring av koldioxid, June 20.
- Teir, S. Fixation of carbon dioxide by producing carbonates from minerals and steelmaking slags. Doctoral dissertation. TKK Dissertations 119, ISBN: 978-951-22-9352-0, Helsinki University of Technology, Espoo, 6/2008.
- Teir, S., Eloneva, S. and Zevenhoven, R. 2005. Production of precipitated calcium carbonate from calcium silicates and carbon dioxide. *Energy Conversion and Management*, 46, pp. 2954–2979.
- Teir, S., Aatos, S., Isomäki, O-P., Kontinen, A. and Zevenhoven, R. 2006. Silikaattimineraalien karbonoiminen hiilidioksidin loppusijoitusmenetelmänä Suomen oloissa (Silicate mineral carbonation as a possible sequestration method of carbon dioxide in Finland). Finnish Association of Mining and Metallurgical Engineers. *Materialia*, 1/2006, pp. 40–46.
- TEM, 2010. Tilastotietoja vuoriteollisuudesta 2007. Työ- ja elinkeinoministeriö (Ministry of Employment and the Economy). <http://www.kaivostoiminta.fi/tilastot2007/vuoriteollisuus.html> [Accessed 17.5.2010]. (In Finnish)
- Tokushige, K., Akimoto, K. and Tomoda, T. 2007. Public acceptance and risk-benefit perception of CO<sub>2</sub> geological storage for global warming mitigation in Japan. *Mitigation and Adaption Strategies for Global Change*, Vol. 12, No. 4, pp. 1237–1251.
- Torróntegui, M. D. 2010. Assessing the Mineral Carbonation Science and Technology. Master Thesis. Institute of Process Engineering, ETH Swiss Federal Institute of Technology Zürich, 51 p.
- ULCOS, 2010. Consortium web page. <http://www.ulcos.org> (last visited October 2010).

- UNFCCC, 2010. National Inventory Submissions 2007, 2009 and 2010. United Nations Framework Convention on Climate Change. [http://unfccc.int/national\\_reports/annex\\_i\\_ghg\\_inventories/items/2715.php](http://unfccc.int/national_reports/annex_i_ghg_inventories/items/2715.php)
- USGS, 2009. 2007 Minerals Yearbook. Denmark, the Faroe Islands, and Greenland; Iceland. Advance Release. U.S. Geological Survey. <http://minerals.usgs.gov/minerals/pubs/country/europe.html#da>
- Vajjhala, S.P. and Fischbeck, P.S. 2007. Quantifying siting difficulty: A case study of US transmission line siting. *Energy Policy*, Vol. 35, Issue 1, January 2007, pp. 650–671.
- Vangkilde-Pedersen, T., Lyng Anthonsen, K., Smith, N., Kirk, K., Neele, F., van der Meer, B., Le Gallo, Y., Bossie-Codreanu, D., Wojcicki, A., Le Nindre, Y.-M., Hendriks, C., Dalhoff, F., Christensen, N.P. 2008. Assessing European capacity for geological storage of carbon dioxide – the EU GeoCapacity project. 9th International Conference on Greenhouse Gas Control Technologies, Washington, 16–20 November 2008.
- Vanstone, R.W. 2005. Advanced Material for AD700 Steam Turbines. AD700 – Advanced 700 PF Power Plant, A Clean Coal European Technology, 27 October 2005, Milan.
- Vattenfall, 2010. Vattenfall's CCS demonstration project in northern Denmark. Web page. <http://www.vattenfall.com/en/ccs/northern-denmark.htm>
- Verduyn, M. and Zimmermann, A. 2010. Techno-Economic Analysis of Opportunities for CCS By Mineralization. Proceedings of the International Conference on Greenhouse Gas Technologies (GHGT-10), 19–23 September 2010, Amsterdam, The Netherlands.
- Voosen, P. 2010. A Town's Lonely Struggle Shows CO<sub>2</sub> Fears Here to Stay, By Paul Voosen of Greewire, New York Times, May 11, 2010.
- World Resources Institute (WRI) (forthcoming) Guidelines for Community Engagement regarding Carbon Dioxide Capture and Storage (CCS) Projects, February 2010 updated draft for stakeholder second review.
- Zevenhoven, R. 2010. Personal communication, 14.10.2010.
- Zevenhoven, R., Romão, I., Fagerlund, J. and Nduagu, E. 2010. CO<sub>2</sub> Fixation Using Magnesium Silicate Minerals. Part 2: Process Energy Efficiency. Proceedings of ECOS2010, Lausanne, Switzerland, June 14–17, 2010.

Åkerman, C. 2003. Nickel exploration in northern Sweden by the Outokumpu Oyj company. In: Ripa, M. (ed.). Economic Geology Research. Vol. 2, 2001–2002. Uppsala 2003. Sveriges geologiska undersökning Rapporter och meddelanden 113, pp. 55–61. ISBN 91-7158-684-9. [http://www.sgu.se/dokument/service\\_sgu\\_publ/RM\\_113\\_akerman.pdf](http://www.sgu.se/dokument/service_sgu_publ/RM_113_akerman.pdf)

## Appendix A1: Facilities with CO<sub>2</sub> emissions > 0.1 Mt CO<sub>2</sub>/a in 2007 – Finland

Facility	Total CO <sub>2</sub> (t/a)	Fossil CO <sub>2</sub> (t/a)	Biogenic CO <sub>2</sub> (t/a)	Sector
Rautaruukki Oyj, Raahen terästehtas	4 722 000	4 722 000	N/A	Iron and steel production
Neste Oil Oyj, Porvoon jalostamo	2 750 000	2 750 000	N/A	Oil and gas refineries
Stora Enso Oyj, Imatran tehtaat	2 716 000	180 000	2 536 000	Pulp and paper production
Fortum Power and Heat Oy, Meri-Porin voimalaitos	2 530 000	2 530 000	N/A	Power & heat production
UPM-Kymmene Oyj, Pietarsaaren tehtaat	1 960 000	74 000	1 886 000	Pulp and paper production
Oy Alholmens Kraft Ab, Pietarsaaren voimalaitos	1 890 000	1 460 000	430 000	Power & heat production
UPM-Kymmene Oyj, Kaukaan tehtaat	1 864 000	155 000	1 709 000	Pulp and paper production
Helsingin Energia, Vuosaaren voimalaitokset	1 660 000	1 660 000	N/A	Power & heat production
Stora Enso Oyj, Oulun tehdas	1 596 000	407 000	1 189 000	Pulp and paper production
Metsä-Botnia Oy, Kemin tehdas	1 563 000	63 000	1 500 000	Pulp and paper production
Fortum Power and Heat Oy, Naantalin voimalaitos	1 450 000	1 450 000	N/A	Power & heat production
Stora Enso Oyj, Veitsiluodon tehtaat	1 371 000	378 000	993 000	Pulp and paper production
Metsä-Botnia Oy, Joutsenon tehdas	1 344 000	84 000	1 260 000	Pulp and paper production
Metsä-Botnia Oy, Rauman tehtaat	1 330 000	61 000	1 269 000	Pulp and paper production
Oulun Energia, Toppilan voimalaitokset	1 320 000	1 140 000	180 000	Power & heat production
Vaskiluodon Voima Oy, Vaskiluoto 2-voimalaitos	1 260 000	1 260 000	N/A	Power & heat production
Helsingin Energia, Hanasaari B-voimalaitos	1 140 000	1 140 000	N/A	Power & heat production
UPM-Kymmene Oyj, Kymi	1 087 000	103 000	984 000	Pulp and paper production
PVO-Lämpövoima Oy, Kristiinän voimalaitos	1 020 000	1 020 000	N/A	Power & heat production
Kanteleen Voima Oy, Haapaveden voimalaitos	992 000	989 000	3 000	Power & heat production
Helsingin Energia, Salmisaaren voimalaitokset	981 000	981 000	N/A	Power & heat production
PVO-Lämpövoima Oy, Tahkoluodon voimalaitos	978 000	978 000	N/A	Power & heat production

Vaskiluodon Voima Oy, Seinäjoen voimalaitos	954 000	924 000	30 000	Power & heat production
Fortum Power and Heat, Inkoon voimalaitos	897 000	897 000	N/A	Power & heat production
Ovako Wire Oy Ab, Koverharin terästehdas	885 000	885 000	N/A	Iron and steel production
UPM-Kymmene Oyj, Tervasaaren tehtaot	869 000	307 000	562 000	Pulp and paper production
Metsä-Botnia Oy, Äänekosken tehtaot	844 000	22 000	822 000	Pulp and paper production
Fortum Power and Heat Oy, Suomenojan voimalaitos	821 000	821 000	N/A	Power & heat production
Stora Enso Oyj, Varkauden tehtaot	786 000	132 000	654 000	Pulp and paper production
Jyväskylän Energiantuo- tanta Oy, Rauhalahden voimalaitos	785 000	505 000	280 000	Power & heat production
Vantaan Energia Oy, Martinlaakson voimalaitos	739 000	739 000	N/A	Power & heat production
Tampereen Energiantuo- tanta Oy, Naistenlahden voimalaitos	719 000	649 000	70 000	Power & heat production
Lahti Energia Oy, Kymijärven voimalaitos	714 000	694 000	20 000	Power & heat production
Outokumpu Stainless Oy, Tornion tehtaot	636 000	636 000	N/A	Iron and steel production
Finnsementti Oy, Parais- ten sementtitehdas	621 000	621 000	N/A	Cement and lime production
Enocell Oy, Enocell Oy:n sellutehdas	598 000	76 000	522 000	Pulp and paper production
Kuopion Energia Oy, Haapaniemen voimalaitos	597 000	577 000	20 000	Power & heat production
Etelä-Savon Energia Oy, Pursialan lämmitys- voimalaitos	515 000	205 000	310 000	Power & heat production
Kymin Voima Oy, Kuusan- kosken voimalaitos	506 000	104 000	402 000	Power & heat production
Rauman Voima Oy, Rauman Voima	499 000	49 000	450 000	Power & heat production
Fortum Power and Heat Oy, Joensuun voimalaitos	478 000	258 000	220 000	Power & heat production
Stora Enso Oyj, Kotkan tehtaot	474 000	271 000	203 000	Pulp and paper production
Pori Energia Oy, Aittaluodon voimalaitos	442 000	312 000	130 000	Power & heat production
Stora Enso Oyj, Anjalankosken tehtaot	432 000	392 000	40 000	Pulp and paper production
Neste Oil Oyj, Naantalin erikoistuotejalostamo	412 000	412 000	N/A	Oil and gas refineries
Kainuun Voima Oy, Kajaanin höyry- ja lämpö- voimalaitos	391 000	291 000	100 000	Power & heat production
Borealis Polymers Oy,	383 000	383 000	N/A	Production of chemicals



Olefiinutuotanto

Finnsementti Oy, Lappeenrannan sementtitehdas	368 000	368 000	N/A	Cement and lime production
Stora Enso Oyj, Heinolan Flutingtehdas	367 000	175 000	192 000	Pulp and paper production
Äänevoima Oy, Äänekosken voimalaitos	363 000	83 000	280 000	Power & heat production
UPM-Kymmene Oyj, Jämsänkosken voimalaitos	362 000	160 000	202 000	Pulp and paper production
UPM-Kymmene Oyj, Kaipolan tehtaas	342 000	149 000	193 000	Pulp and paper production
Kuitu Finland Oy, Säterin voimalaitos	320 000	160 000	160 000	Power & heat production
Laanilan Voima Oy, Oulun voimalaitos	309 000	259 000	50 000	Power & heat production
Mussalon Kaukolämpö Oy, Mussalo 1-voimalaitos	307 000	307 000	N/A	Power & heat production
Fortum Power and Heat Oy, Kirkniemen voimalaitos	306 000	306 000	N/A	Power & heat production
Tampereen Energiantuo- tanta Oy, Lielahden voimalaitos	298 000	298 000	N/A	Power & heat production
Myllykoski Paper Oy, Myllykosken paperitehdas ja voimalaitos	287 000	117 000	170 000	Pulp and paper production
Fortum Power and Heat Oy, Uimaharjun voimalaitos	287 000	17 000	270 000	Power & heat production
Sunila Oy, Sunila Oyn sellutehdas	268 932	47 000	221 932	Pulp and paper production
Porin Prosessivoima Oy, Porin tehdas	264 000	264 000	N/A	Power & heat production
Rovaniemen Energia Oy, Suosiolan voimalaitos	240 000	210 000	30 000	Power & heat production
M-Real Oyj, Simpeleen tehdas	216 000	116 000	100 000	Pulp and paper production
Mäntän Energia Oy, Mäntän voimalaitos	210 000	170 000	40 000	Power & heat production
Nordkalk Oyj Abp, Tytyrin kalkkitehdas	189 000	189 000		Cement and lime production
Vattenfall Lämpö Oy, Hämeenlinnan voimalaitos	189 000	159 000	30 000	Power & heat production
Savon Sellu Oy, Savon sellu	188 000	128 000	60 000	Pulp and paper production
Stora Enso Publication Papers Oy, Summan tehtaas	187 000	17 000	170 000	Pulp and paper production
M-real Oyj, Kyrökosken voimalaitos	177 000	177 000	N/A	Pulp and paper production
Fortum Power and Heat Oy, Kokkolan voimalaitos	172 000	172 000	N/A	Power & heat production
Järvi-Suomen Voima Oy,	159 000	29 000	130 000	Power & heat production

Savonlinnan voimalaitos

Lappeenrannan Lämpövoima Oy, Mertaniemen voimalaitos	158 000	158 000	N/A	Power & heat production
Nokian Lämpövoima Oy, Nokian voimalaitos	157 000	157 000	N/A	Power & heat production
Kotkan Energia Oy, Hovinsaaren voimalaitos	157 000	137 000	20 000	Power & heat production
Ekokem Oy Ab, Riihimäen toimipiste	154 000	154 000		Waste treatment or incineration
Kokkolan Voima Oy, Kokkolan lämmitysvoimalaitos	146 000	96 000	50 000	Power & heat production
Järvi-Suomen Voima Oy, Ristiinan voimalaitos	144 000	4 000	140 000	Power & heat production
Lahti Energia Oy, Heinolan voimalaitos	118 000	8 000	110 000	Power & heat production
SMA Mineral Oy, Röyttän Kalkkitehdas	109 000	86 000	23 000	Cement and lime production
Turku Energia Oy, Orikedon lämpökeskus	109 000	9 000	100 000	Power & heat production
Savon Voima Lämpö Oy, Iisalmen voimalaitos	109 000	69 000	40 000	Power & heat production
Nordkalk Oyj Abp, Lappeenrannan tehtaat	104 000	90 000	14 000	Cement and lime production

---

## Appendix A2: Facilities with CO<sub>2</sub> emissions > 0.1 Mt CO<sub>2</sub>/a in 2007 – Denmark

Facility	Total CO <sub>2</sub> (t/a)	Fossil CO <sub>2</sub> (t/a)	Biogenic CO <sub>2</sub> (t/a)	Sector
DONG Energy A/S - Asnæsværket	3 250 000	3 250 000	0	Power & heat production
DONG Energy A/S - Avedøreværket	2 829 407	2 190 000	639 407	Power & heat production
Aalborg Portland	2 760 000	2 760 000	0	Cement and lime production
Vattenfall A/S Nordjyllandsværket	2 760 000	2 760 000	0	Power & heat production
Dong Energy A/S Studstrupværket	2 521 909	2 340 000	181 909	Power & heat production
DONG A/S Enstedværket	2 062 449	1 860 000	202 449	Power & heat production
DONG A/S - Esbjergværket	1 810 000	1 810 000	0	Power & heat production
Vattenfall A/S Fynsværket	1 800 000	1 800 000	0	Power & heat production
Vattenfall A/S Amagerværket	1 466 097	1 330 000	136 097	Power & heat production
DONG Energy A/S - Stigsnæsværket	904 000	904 000	0	Power & heat production
Tyra feltet	654 000	654 000	0	Offshore oil and gas activities
Dan feltet	572 000	572 000	0	Offshore oil and gas activities
I/S Vestforbraending	517 597	517 597	0	Waste treatment or incineration
DONG A/S, Skærbækværket	508 000	508 000	0	Power & heat production
Statoil A/S raffinaderi	487 000	487 000	0	Oil and gas refineries
A/S Dansk Shell - Raffinaderiet	473 000	473 000	0	Oil and gas refineries
Gorm feltet	448 000	448 000	0	Offshore oil and gas activities
Amagerforbraending	414 882	414 882	0	Waste treatment or incineration
DONG Energy A/S - H.C. Ørstedsværket	334 000	334 000	353	Power & heat production
Herningværket	330 906	54 126	276 780	Power & heat production
Energi Randers Production A/S	300 996	186 000	114 996	Power & heat production
Maabjergværket	262 299	185 187	77 112	Waste treatment or incineration
DONG Energy A/S - Svanemølleværket	245 000	245 000	0	Power & heat production
Affaldscenter Aarhus - Forbrændingsanlægget	236 189	236 189	0	Waste treatment or incineration

L90 Affaldsforbraending	215 097	215 097	0	Waste treatment or incineration
Syd Arne feltet	210 000	210 000	0	Offshore oil and gas activities
I/S Kara Affaldsforbraendingsanlaeg	203 259	203 259	0	Waste treatment or incineration
Kommunekemi A/S	183 708	183 708	0	Waste treatment or incineration
I/S Reno Nord	182 731	182 731	0	Waste treatment or incineration
Silkeborg KRAFTVARMEVÆRK A/S	170 000	170 000	0	Power & heat production
Koege Kraftvarmevaerk	169 636	2 606	167 030	Waste treatment or incineration
VATTENFALL A/S Hillerød Kraftvarmeværk	163 000	163 000	0	Power & heat production
I/S Nordforbraending	141 338	126 133	15 206	Waste treatment or incineration
Sønderborg Kraftvarmeværk	126 932	126 682	250	Waste treatment or incineration
Halfdan feltet	126 353	126 353	0	Offshore oil and gas activities
Viborg Kraftvarmeværk A/S	124 000	119 789	0	Power & heat production
I/S Fasan - Naestved Kraftvarmevaerk	121 941	121 941	0	Waste treatment or incineration
Dalum Papir	117 612	9 211	108 401	Pulp and paper production
Maxit Hinge	117 000	117 000	0	Cement and lime production
Kolding Forbraending-sanlaeg	116 773	116 545	228	Waste treatment or incineration
REFA	116 518	116 518	0	Waste treatment or incineration
Novo Nordisk A/S - Kalundborg	115 000	5 000	110 000	Production of chemicals
Grenaa Kraftvarmevaerk	110 209	51 825	58 384	Power & heat production
Kavo I/S Ener- gien+Slagelse Kraftvarme- vaerk	107 961	66 622	41 339	Waste treatment or incineration
Nordic Sugar Nakskov	107 868	105 334	2 534	Other
Siri feltet omfattende anlæg på Siri platformen	107 000	107 000	0	Offshore oil and gas activities
AarhusKarlshamn Den- mark A/S	103 000	103 000	0	Other

## Appendix A3: Facilities with CO<sub>2</sub> emissions > 0.1 Mt CO<sub>2</sub>/a in 2007 – Sweden

Facility	Total CO <sub>2</sub> (t/a)	Fossil CO <sub>2</sub> (t/a)	Biogenic CO <sub>2</sub> (t/a)	Sector
SSAB Oxelösund AB	2 420 000	2 420 000	0	Iron and steel production
Luleå kraftvärmeverk LUKAB	2 210 000	2 210 000	0	Power & heat production
M-real Sverige AB, Husums fabrik	1 970 000	120 000	1 850 000	Pulp and paper production
Södra Cell Mönsterås	1 940 000	68 000	1 872 000	Pulp and paper production
Preemraff, Lysekil	1 630 000	1 630 000	0	Oil and gas refineries
Gruvöns bruk	1 560 000	56 000	1 504 000	Pulp and paper production
Stora Enso, Skutskärs bruk	1 538 000	46 000	1 492 000	Pulp and paper production
Korsnäsverken	1 460 000	21 000	1 439 000	Pulp and paper production
Östrands massafabrik	1 430 000	90 000	1 340 000	Pulp and paper production
Cementa AB, Slitefabriken	1 430 000	1 390 000	40 000	Cement and lime production
SSAB Tunnpå AB	1 370 000	1 370 000	0	Iron and steel production
Smurfit Kappa Kraftliner Piteå	1 330 000	50 000	1 280 000	Pulp and paper production
Södra Cell Mörrum	1 170 000	57 000	1 113 000	Pulp and paper production
Billerud Skärblacka AB	1 020 000	49 000	971 000	Pulp and paper production
Södra Cell Värö	1 010 000	36 000	974 000	Pulp and paper production
Västerås kraftvärmeverk	980 000	644 000	336 000	Power & heat production
Skoghalls Bruk	877 000	66 000	811 000	Pulp and paper production
Billerud Karlsborgs AB	805 000	15 000	790 000	Pulp and paper production
VÄRTAVERKET	779 000	630 000	149 000	Power & heat production
Iggesund Paperboard AB, Iggesund Bruk	776 000	88 000	688 000	Pulp and paper production
STORA ENSO NYMÖLLA AB	768 000	0	768 000	Pulp and paper production
Borealis Krackeranl.	678 000	678 000	0	Production of chemicals
SCA Munksund	671 000	30 400	640 600	Pulp and paper production
Korsnäs Frövi AB	625 000	33 000	592 000	Pulp and paper production
Händelöverket	620 000	123 000	497 000	Waste treatment or incineration
Mondi Dynäs AB	578 000	17 600	560 400	Pulp and paper production
Domsjö Fabriker AB	577 000	16 000	561 000	Pulp and paper production
Boländeranläggningarna, Avfallsförbränning- sanläggning	571 000	256 000	315 000	Power & heat production
Vallviks Bruk	569 000	7 000	562 000	Pulp and paper production
Bäckhammars Bruk	491 000	19 000	472 000	Pulp and paper production
STORA ENSO KVARNSVEDEN AB	477 000	78 000	399 000	Pulp and paper production

Preem Petroleum AB Preemraff Göteborg	475 000	475 000	0	Oil and gas refineries
E ON Värme Sverige AB, Åbyverket	474 000	111 000	363 000	Power & heat production Waste treatment or incineration
Sävenäs	471 000	134 000	337 000	Waste treatment or incineration
Cementa AB Skövde- fabriken	467 000	461 000	6 000	Cement and lime production
Shell Raffinaderi AB	463 000	463 000	0	Oil and gas refineries
SCA Packaging Obbola AB	454 000	62 000	392 000	Pulp and paper production
Munksjö Aspa Bruk AB	452 000	32 000	420 000	Pulp and paper production
Rya Gaskraftvärmeverk	398 000	398 000	0	Power & heat production
Sysavs avfallsförbränning- sanläggning	386 000	116 000	270 000	Waste treatment or incineration
Avfallskraftvärmeverket Torsvik	380 000	48 600	331 400	Waste treatment or incineration
SSAB Tunnbrått i Borlänge	369 000	369 000	0	Iron and steel production
HÄSSELBYVERKET	351 000	4 000	347 000	Power & heat production
Kraftvärmeverket & Hetvattencentralen Vattumannen	339 000	9 500	329 500	Power & heat production
Västhamnsverket, (VHV)	325 000	14 000	311 000	Power & heat production Waste treatment or incineration
Gärstadverket	324 000	48 600	275 400	Waste treatment or incineration
Ryaverket	323 000	49 700	273 300	Power & heat production
BRISTAVERKET	302 000	1 000	301 000	Power & heat production
Ortvikens pappersbruk	286 000	25 000	261 000	Pulp and paper production
LKAB - Kirunagruvan	279 000	279 000	0	Iron and steel production
Lugnviksverket	268 000	48 000	220 000	Power & heat production
Karskärsverket	263 000	116 000	147 000	Power & heat production
Sandviksverket	261 000	22 000	239 000	Power & heat production
CEMENTA, Degerhamn	240 000	238 000	2 000	Cement and lime production
Kraftvärmeverket i Linköping	239 000	110 000	129 000	Power & heat production
Bravikens Pappersbruk	235 000	78 000	157 000	Pulp and paper production
Höganäs AB	230 000	230 000	0	Iron and steel production
HALLSTA PAPPERSBRUK	228 000	42 000	186 000	Pulp and paper production
Nordkalk / Köping	224 000	224 000	0	Cement and lime production
Vargön Alloys AB	220 000	220 000	0	Non-ferrous metal production
Ildbäckens Kraftvärmeverk	216 000	2 600	213 400	Power & heat production
IGELSTAVERKET	197 000	197 000	0	Power & heat production
RÖNNSKÄRSVERKEN	182 000	182 000	0	Non-ferrous metal production
Pilkington Floatglas AB	173 000	173 000	0	Other
STORA ENSO FORS AB	172 000	7 000	165 000	Pulp and paper production
Kalkproduktion AB	170 000	170 000	0	Cement and lime production
KVV-Åkerslund	168 000	3 000	165 000	Power & heat production

DÅVA				Waste treatment or incineration
KRAFTVÄRMEVERK	167 000	40 500	126 500	
Heleneholmsverket, (HVK)	155 000	155 000	0	Power & heat production
Kubikenborg Aluminium AB	154 000	154 000	0	Non-ferrous metal production
Karlskoga kraftvärmeverk	151 000	36 700	114 300	Power & heat production
HPC Simpan och Ena Kraft, kraftvärmeverket	138 000	0	138 000	Power & heat production
SAKAB AB	147 000	147 000	0	Waste treatment or incineration
Munksjö Paper AB Billingsfors	144 000	15 000	129 000	Pulp and paper production
Nynäshamns Raffinaderiet	143 000	143 000	0	Production of chemicals
Perstorp Specialty Chemicals AB, Ångcentralen	138 000	47 000	91 000	Power & heat production
LKAB - Malmbergsgruvan	136 000	136 000	0	Non-ferrous metal production
SOLNAVERKET	131 000	3 000	128 000	Power & heat production
Heden kraftvärmeverk	128 000	1 000	127 000	Power & heat production
AB Sandvik Materials Technology	125 000	125 000	0	Iron and steel production
ÅLIDHEMSANLÄGGNING EN	123 000	50 000	73 000	Power & heat production
SMA Svenska Mineral AB, RÄTTVIKS KALKVERK	120 000	120 000	0	Cement and lime production
HAMMARBYVERKET	118 000	0	118 000	Power & heat production
Perstorp Oxo AB, Stenungsund	120 000	120 000	0	Production of chemicals
Sävenäs Kraftvärmeverk	117 000	5 000	112 000	Power & heat production
OVAKO Steel AB	106 000	106 000	0	Iron and steel production
Allöverket	106 000	1 000	105 000	Power & heat production
Nordkalk AB Luleå	105 000	105 000	0	Cement and lime production

## Appendix A4: Facilities with CO<sub>2</sub> emissions > 0.1 Mt CO<sub>2</sub>/a in 2007 – Norway

Facility	Total CO <sub>2</sub> (t/a)	Fossil CO <sub>2</sub> (t/a)	Biogenic CO <sub>2</sub> (t/a)	Sector
STATOIL ASA, Mongstad	1 640 000	1 640 000		Oil and gas refineries
Hammerfest LNG	1 620 000	1 620 000		Oil and gas refineries
Statoil ASA Osebergfeltet	1 240 000	1 240 000		Offshore oil and gas activities
Gassco AS, Kårstø	1 154 000	1 154 000		Oil and gas refineries
Statoil ASA Gullfaksfeltet	1 060 000	1 060 000		Offshore oil and gas activities
Statoil ASA Åsgardfeltet	1 008 000	1 008 000		Offshore oil and gas activities
ConocoPhillips Skandinavia AS Ekofiskområdet	1 002 000	1 002 000		Offshore oil and gas activities
Norcem A.S., Brevik	975 000	858 000	117 000	Cement and lime production
Statoil ASA Statfjordfeltet	967 000	967 000		Offshore oil and gas activities
Statoil ASA Sleipnerfeltet	861 000	861 000		Offshore oil and gas activities
Yara Norge AS, Yara Porsgrunn	723 000	723 000		Production of chemicals
Statoil ASA Troll B og C	634 000	634 000		Offshore oil and gas activities
Hydro Aluminium AS Sunndal	622 000	622 000		Non-ferrous metal production
Statoil ASA Snorrefeltet	503 000	503 000		Offshore oil and gas activities
Hydro Aluminium AS Karmøy	494 000	494 000		Non-ferrous metal production
NORETYL AS	451 000	451 000		Production of chemicals
NORCEM AS, Kjøpsvik	444 000	432 000	12 000	Cement and lime production
Statoil ASA Heidrunfeltet	390 000	390 000		Offshore oil and gas activities
ESSO NORGE AS, Slagentangen	386 000	386 000		Oil and gas refineries
Finnfjord AS	376 000	217 000	159 000	Iron and steel production
Trelleborg Offshore Norway AS	368 000	368 000		Production of chemicals
Hydro Aluminium AS Årdal, Årdal Metallverk	349 000	349 000		Non-ferrous metal production
Tinfos Titan & Iron K.S	332 000	332 000		Iron and steel production
Marathon Petroleum Company Alvheim	344 000	344 000		Offshore oil and gas activities
PETERSON LINERBOARD AS, Moss	312 000	57 000	255 000	Pulp and paper production



StatoilHydro Tjeldbergodden Metanolfabrikk	308 000	308 000		Production of chemicals
Alcoa Mosjøen	295 000	295 000		Non-ferrous metal production
Statoil ASA Visundfeltet	282 000	282 000		Offshore oil and gas activities
Elkem ASA Bremanger	273 000	231 000	42 000	Production of chemicals
Borregaard Ind. Ltd., Cellulosesektor	273 000	172 000	101 000	Pulp and paper production
Tinfos Jernverk	269 000	269 000		Iron and steel production
ERAMET NORWAY AS, Sauda	267 000	267 000		Iron and steel production
Bp Norge AS Valhallfeltet	266 000	266 000		Offshore oil and gas activities
Elkem Salten	251 000	206 000	45 000	Production of chemicals
Sør-Norge Aluminium	249 000	249 000		Non-ferrous metal production
FESIL ASA, Holla Metall	246 000	200 000	46 000	Production of chemicals
Elkem Thamshavn AS	244 000	203 000	41 000	Production of chemicals
Statoil ASA Nornefeltet	235 000	235 000		Offshore oil and gas activities
Statoil ASA Granefeltet	234 000	234 000		Offshore oil and gas activities
Statoil ASA Veslefrikk og Huldrafeltet	226 000	226 000		Offshore oil and gas activities
Statoil ASA Bragefeltet	203 000	203 000		Offshore oil and gas activities
Norske Skog Skogn	200 000	7 000	193 000	Pulp and paper production
Statoil ASA Njordfeltet	197 000	197 000		Offshore oil and gas activities
Statoil ASA Kristinfeltet	197 000	197 000		Offshore oil and gas activities
Fesil Rana Metall AS	192 000	187 000	5 000	Iron and steel production
Elkem Bjølvefossen	181 000	161 000	20 000	Iron and steel production
ExxonMobil Exploration and Production Norway AS Jotunfeltet	180 000	180 000		Offshore oil and gas activities
A/S Norske Shell Draugenfeltet	180 000	180 000		Offshore oil and gas activities
Elkem Aluminium ANS, Lista	177 000	177 000		Non-ferrous metal production
Statoil ASA Volvefeltet	177 000	177 000		Offshore oil and gas activities
Statoil ASA Heimdalfeltet	168 000	168 000		Offshore oil and gas activities
ExxonMobil Exploration and Production Norway AS Jotunfeltet	163 000	163 000		Offshore oil and gas activities
NORSKE SKOINDUSTRIER ASA, Saugbrugs	145 000	20 000	125 000	Pulp and paper production

Bp Norge AS Ulafeltet	137 000	137 000		Offshore oil and gas activities
Norske Skogindustrier ASA, Follum Fabrikker	121 000	3 000	118 000	Pulp and paper production
Hydro Aluminium AS Årdal, Årdal Karbon	120 000	120 000		Other
INEOS Norge AS	113 000	113 000		Production of chemicals

---

## Appendix A5: Facilities with CO<sub>2</sub> emissions > 0.1 Mt CO<sub>2</sub>/a in 2007 – Iceland

Facility	Total CO <sub>2</sub> (t/a)	Fossil CO <sub>2</sub> (t/a)	Biogenic CO <sub>2</sub> (t/a)	Sector
Elkem Ísland ehf	430 000	430 000	0	Iron and steel production
Norðurál Grundartanga	362 000	362 000	0	Non-ferrous metal production
Alcan á Íslandi hf.	292 000	292 000	0	Non-ferrous metal production



# Appendix B1: Map of facilities with CO<sub>2</sub> emissions > 0.1 Mt CO<sub>2</sub>/a in 2007 – only fossil CO<sub>2</sub> emissions visible

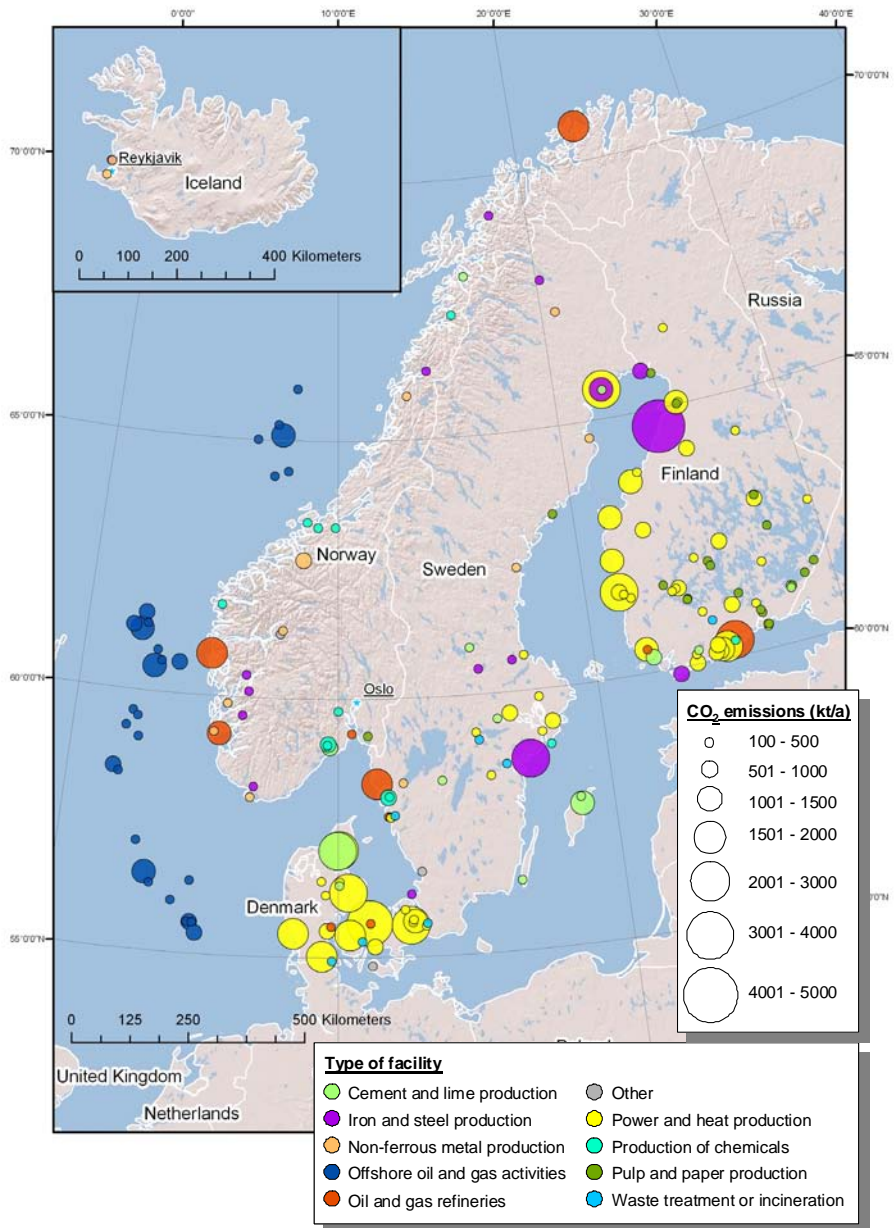

## Appendix B2: Map of facilities with CO<sub>2</sub> emissions > 0.1 Mt CO<sub>2</sub>/a in 2007 – only biogenic CO<sub>2</sub> emissions visible

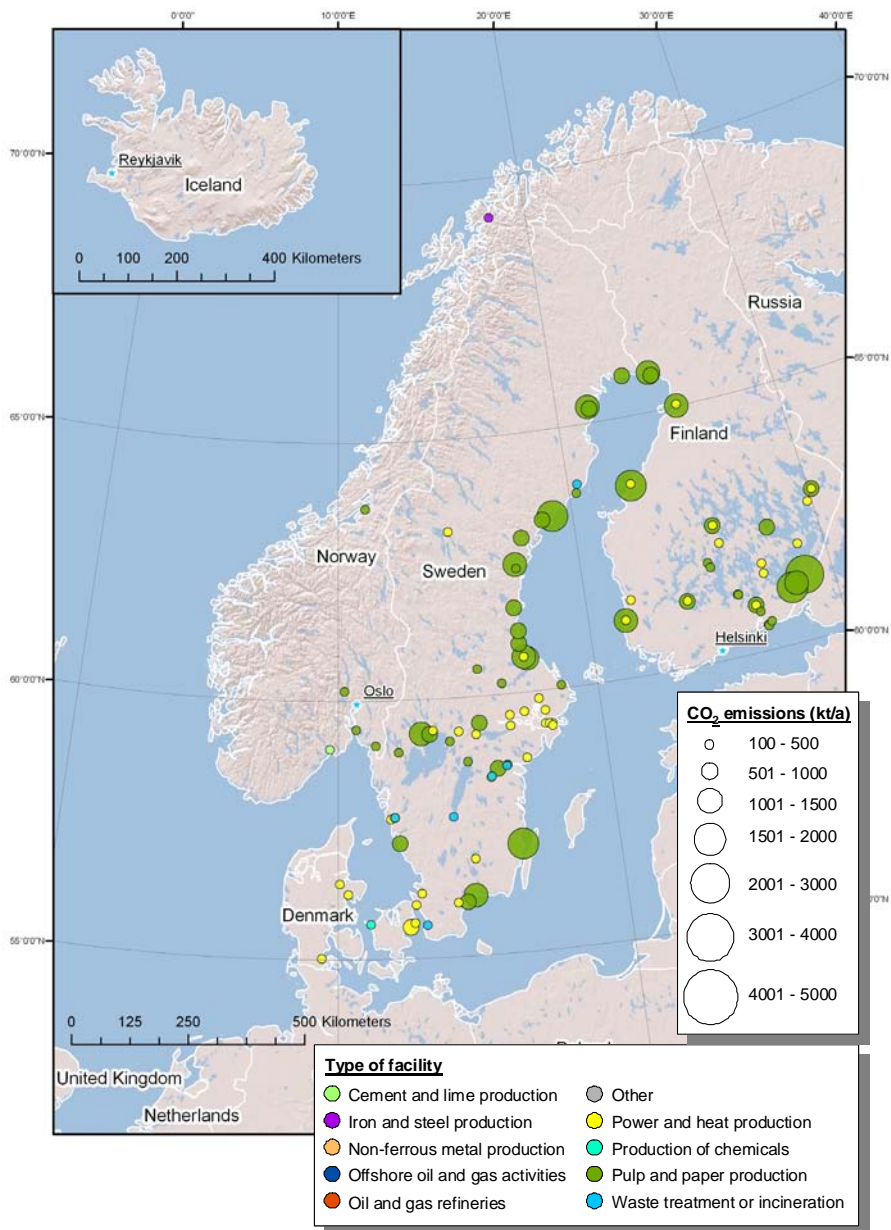

## Appendix B3. Map of facilities with CO<sub>2</sub> emissions > 0.1 Mt CO<sub>2</sub>/a in 2007 – both fossil and biogenic CO<sub>2</sub> emissions visible

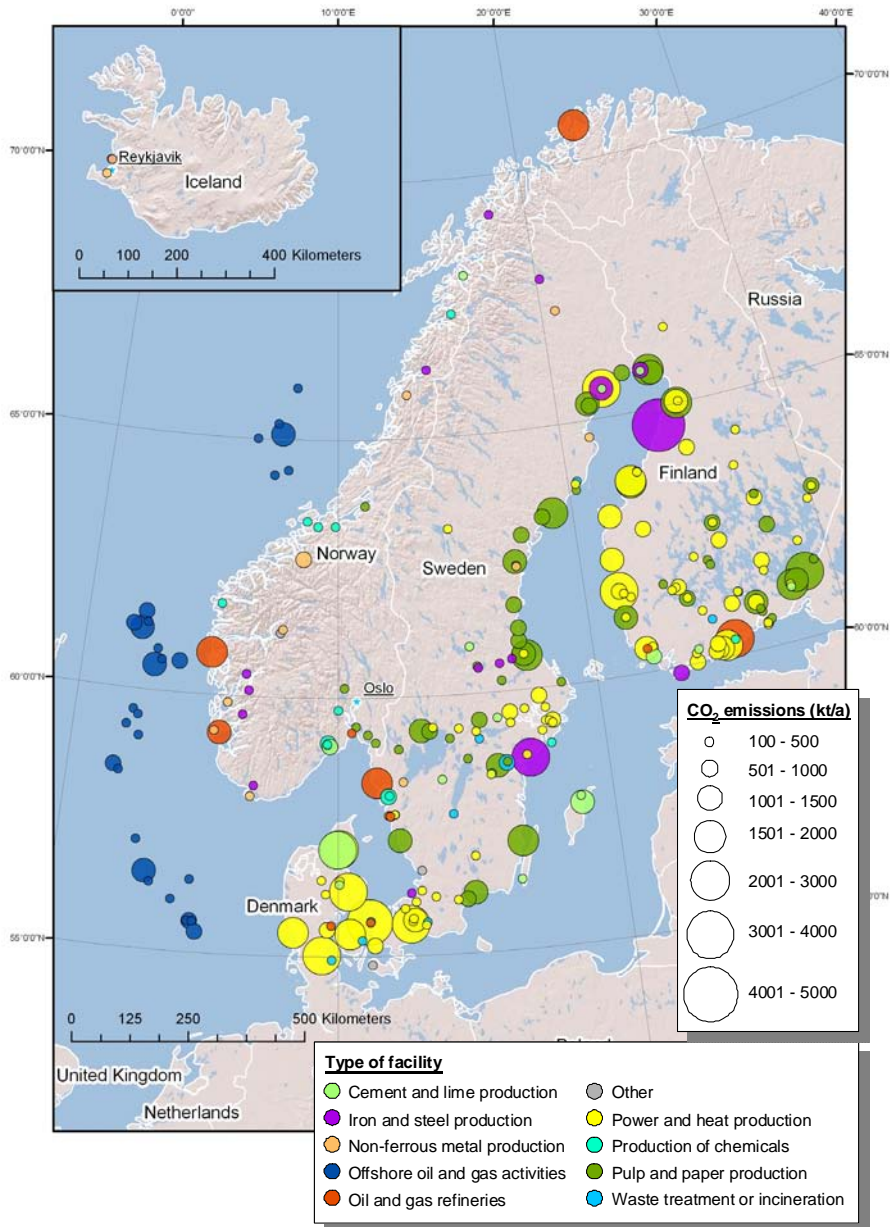

## Appendix B4: Clusters of facilities with CO<sub>2</sub> emissions > 0.1 Mt CO<sub>2</sub>/a in 2007 – both fossil and biogenic CO<sub>2</sub> emissions visible

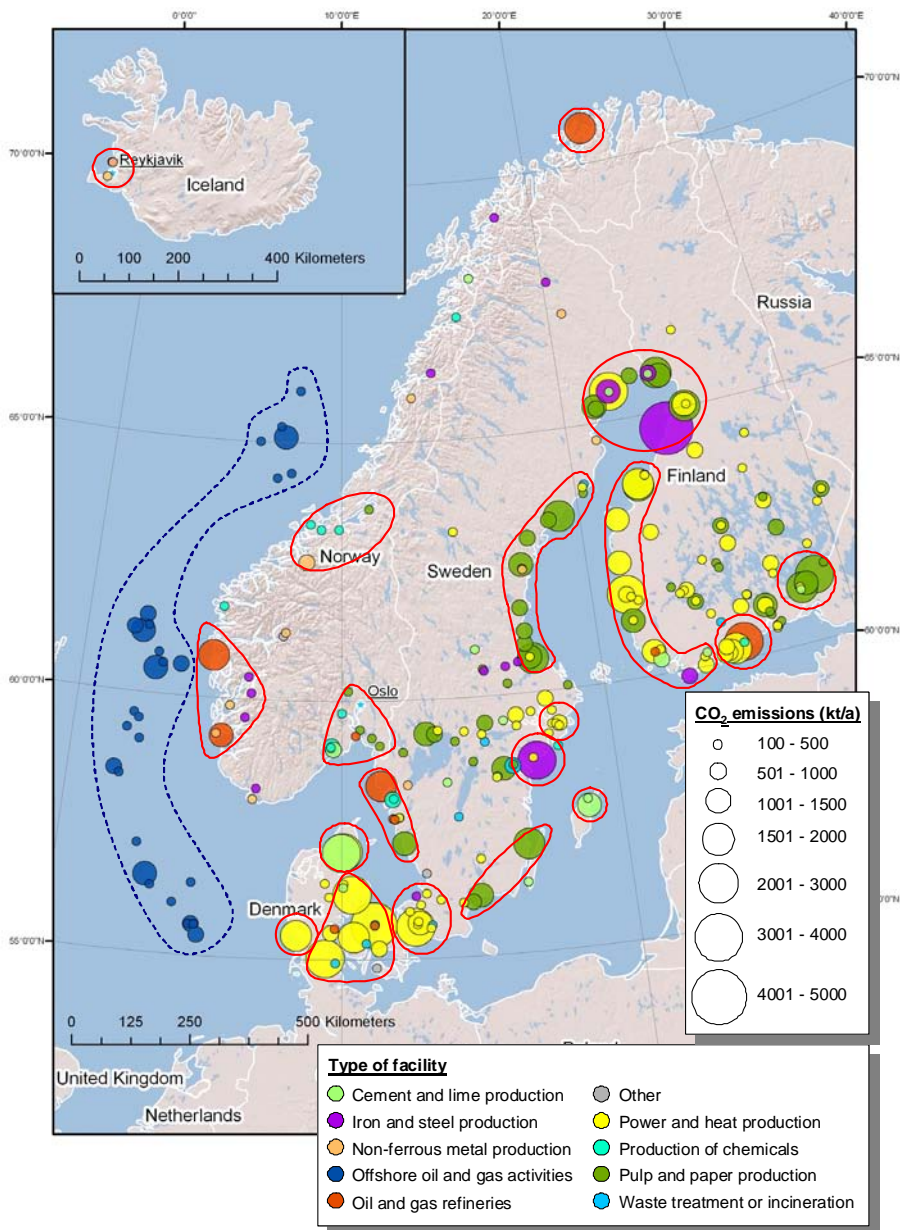



# Appendix C1. Summary of four large-scale CCS projects in operation

Project:		Stejprer	In Salah	Snøhvit	Weyburn
Country		Norway	Algeria	Norway	Canada & USA
Date started		1996	2004	2008	2000
Partners/Participants		Operator: Statoil Licensees: Esso Norge; Norsk Hydro; TotalFinaElf Exploration Norge	Sonatrach, BP, Statoil	Norwegian government; Petoro; TotalFinaElf; Gaz de France; Norsk Hydro; Amerada Hess Norge; RWE-DEA Norge; Svenska Petroleum Exploration	EnCana/Dakota Company
Operator		Statoil	Joint operation by Sonatrach, BP, Statoil	Statoil	EnCana/Dakota Company
Capturing technology		Amine absorption (MDEA)	Amine absorption	Amine absorption	Rectisol
Capture		CO <sub>2</sub> source CO <sub>2</sub> concentrations	Natural gas field 10 vol%	Natural gas field 5 vol%	Coal gasification 95 vol %
Transport mode		On-site injection via pipe	Short pipeline – safe distance from the gas in the same layer ~14km	Pipeline	Pipeline
Distance			~14km	160 km	330 km
Compressed pressure			~185Bar		~185 Bar
Injection rate		1 Mt/y	1 Mt/y	0.7 Mt/y	2.3 Mt/y (up to a total of 20 Mt over the lifetime)*
Storage option		Aquifer	Hydrocarbon Reservoirs	Aquifer	EOR
Funding portfolio		Statoil	Industry sources	Government and industry sources	Government and industry sources
Overall Project Costs		Cost of CO <sub>2</sub> treatment module >350 million Euro	Phase I of gas field development ~ 1.25 billion Euro	3.8 billion Euro (includes four LNG Ships); CO <sub>2</sub> pipeline and injection well ~125 million Euro	Cost of CO <sub>2</sub> pipeline ~75 million Euro

\* IEA GHG (2010)

## Appendix C2. Large-scale CCS projects in preparation

Project name	Partners/ participants	Country	Location	Capture technology	Fuel type	Plant size (MW)	CO <sub>2</sub> produced (Mt/yr)	Start up
Europe:								
BARENDRECHT SHELL	Shell	NL	Barendrecht (storage), Pernis (capture), Rotterdam	H <sub>2</sub> production	Heavy oil	N/A	0.4	2011
ROTTERDAM ENECO	ENECO, International Power	NL	Piscoolhaven, Rotterdam	Post-combustion (solvent TBD)	Gas	845		2011
NORDJYLLANDSVERKET	Vattenfall	Denmark	Aalborg	Post-combustion (solvent TBD)	Hard Coal	380	1.8	2013
EEMSHAVEN NUON	Nuon	NL	Eemshaven	Pre-combustion	Hard Coal, Biomass	1200	2.5	2013
KINGSNORTH E.ON	E.ON UK	UK	Kingsnorth, Southeast England	Post-combustion (solvent TBD)	Hard Coal	400	2.4	2014
MONGSTAD STA TOIL	StatoilHydro, Gassnova	Norway	Bergen	Post-combustion (solvent TBD)	Gas	280 el + 350 heat	1	2014
ENEL CCS1	ENEL	Italy	Porto Tolle	Post-combustion (solvent TBD)	Hard Coal	242 MW <sub>e</sub> net	1.5	2014
HÜRTH RWE	RWE	Germany	Hürth, Northrhine-Westfalia	Pre-combustion	Lignite	450	2.8	2014
ROTTERDAM CGEN	CGEN NV	NL	Europoort, Rotterdam	Pre-combustion	Hard coal, Biomass	450	2.5	2014
Compostilla ENDESA	Endesa	Spain	Compostilla, Leon	Oxy-fuel combustion (CFB)	Sub-bituminous, bituminous and anthracite coals, Pet coke and biomass	500 (400 MW <sub>e</sub> net CCS)	2.75 captured	2015

<i>Project name</i>	<i>Partners/ participants</i>	<i>Country</i>	<i>Location</i>	<i>Capture technology</i>	<i>Fuel type</i>	<i>Plant size (MW)</i>	<i>CO<sub>2</sub> produced (Mt/yr)</i>	<i>Start up</i>
<b>Europe:</b>								
Janschwalde Vattenfall	Vattenfall	Germany	Janschwalde, Brandenburg	Oxy-fuel combustion and post-combustion	Lignite	2.50 (Oxy- fuel) and up to 250 (post)	1.79	2015
FINNCAP Meri Pori	Fortum, TVO	Finland	Meri Pori	Post-combustion	Hard Coal	560 (500)	1	2015
BELCHATOW BOT	Polska Grupa Energetyczna S.A./ PGE Gornictwo i Energetyka S.A./ Power Plant Belchatow/ Alstom/ Institute for Chemical Processing of Coal/ Central Mining Institute/ Polish Geological Institute	Poland	Belchatow	Post-combustion	Lignite	858 MW, (1/3 carbon capture demo)	2	2015
ENEL CCS2 Tilbury	ENEL RWE/Peel/DONG	Italy UK	Tilbury, Thames estuary	Oxy-fuel combustion Post-combustion (solvent TBD)	Hard Coal Hard Coal	320 MW, net 400	2.1 2.4	2016 2016
ROTTERDAM ESSENT	Essemt+ Shell	NL	Rotterdam	Pre-combustion	Hard Coal, Biomass	1000	4	2016
HATFIELD P-FUEL PWR	Powerfuel Power Ltd	UK	Hatfield, South Yorkshire	Pre-combustion	Hard Coal	900	4.75	2012-2014
LONGANNET	Scottish Power	UK	Scotland	Post-combustion (solvent TBD)	Hard Coal	400	2.7	
FLORANGE ARC.MIT	Arcebr/Mittal	France	France	Post-combustion (solvent TBD)	Hard Coal, Petrocoke			

<i>Project name</i>	<i>Partners/ participants</i>	<i>Country</i>	<i>Location</i>	<i>Capture technology</i>	<i>Fuel type</i>	<i>Plant size (MW)</i>	<i>CO<sub>2</sub> produced (Mt / yr)</i>	<i>Start up</i>
<b>North America:</b>								
Quest	Shell	Canada	Alberta	Other	Gas/oil sand		1	2011
Fort Nelson	Spectra Energy	BC Canada	Fort Nelson	Post-combustion	Gas	large (commercial)	2	2011
WASP- Pioneer US Regional partnerships	Transatlanta/ALSTO M Various	Canada USA	Alberta Various	Post-combustion, chilled ammonia Various	Coal Coal		1 typically by 7-9 projects 4 til 5	2012 2012
California CCS Project Tenaska Trailblazer Coal Plant SECARB Boundary Dam FutureGen	Hydrogen energy/Edison Tenaska	USA USA	California Texas	Pre-combustion - IGCC Pre-combustion-IGCC	Coal/pet coke Coal	250 600		2014 2014
	Denbury/DOE SaskPower Alliance	USA Canada USA	Mobile, Alabama Saskatchewan Matton, Illinois	Post-combustion Post-combustion Pre-combustion-IGCC	Coal Coal Coal	pilot 100 275	0.2 1	2014 2015 2018
<b>Rest of the world:</b>								
Hydrogen Power Abu Dhabi	BP/Rio Tinto/Masdar	SAUDI ARABIA	ABU DHABI	Pre-combustion	Gas	420	1.1	2014
GreenGen Gorgon CO <sub>2</sub> Injection Monash CTL	GreenGen Co. Chevron, ExxonMobile, Shell,... Monash Energy	CHINA AUSTRALIA AUSTRALIA AUSTRALIA	Tianjin Gorgon Latrobe Valley	Pre-combustion Amines- natural gas separation (LNG) CTL – other	Coal Natural gas Coal	400 large	2 3.3 15	2015 2009 2016
ZEROGEN Phase 2	ZEROGEN	AUSTRALIA LIA	CENTRAL QUEENSLAND	Pre-combustion IGCC	Coal	400		2017

# Appendix C3. Research and demonstration projects

Project name	Partners/ participants	Country	Location	Capture technology	Fuel type	New vs. retro	Plant size (MW)	Start up
<b>Europe:</b>								
Schwarze Pumpe ECCO	Vattenfall SINTEF	Germany EU FP7	Coitbus EU	Oxy-fuel combustion None	Lignite Project is about large scale infrastructure	New	30	2008 2008
Ketzin CESAR SOL Vit	GFZP TNO AKER/SINTEF/NTNU	germany EU FP7 NORWAY	berlin EU TRONDHEIM	Other Post-combustion Post-combustion	other All All	new	pilot	2008 2008 2008
MITU	AKER CLEAN CARBON	NORWAY	VARIOUS	Post-combustion	Gas and coal	NEW	1	2008
CO <sub>2</sub> Catcher DECARBit CEASAR	TNO, E.ON SINTEF ECN	The Netherlands EU FP7 EU FP7	Rotterdam EU EU	Post-combustion Pre-combustion Pre-combustion	Oil, gas, coal All Gas	new	less than 1	2008 2008 2008
Doosan Babcock	Doosan Babcock	UK		Oxy-fuel combustion	Coal	Pilot	30 (EL)	2009
Lacq TOTAL	Total, ALSTOM, Air liquide	France	Lacq plant and Rousse field	Oxy-fuel combustion	Gas	Retrofit	30	2009
Niederaussem pilot	Linde, BASF, RWE	GERMANY	Niederaussem	Post-combustion	Lignite (coal)	pilot		2009
TEST CENTRE TILLER	SINTEF/NTNU	NORWAY	TRONDHEIM	Post-combustion	All			2009

<i>Project name</i>	<i>Partners/ participants</i>	<i>Country</i>	<i>Location</i>	<i>Capture technology</i>	<i>Fuel type</i>	<i>New vs. retro</i>	<i>Plant size (MW)</i>	<i>Start up</i>
<b>Europe:</b>								
Karlshamn	E.ON	Sweden	Karlshamn	Post-combustion, chilled ammonia	Oil (gas turbine)	pilot		2009
Standinger pilot	Siemens, E.On	GERMANY	grosskrotzenberg	Post-combustion, aminoacid salts	Coal	pilot		2009
Ciuden CCS facility	Ciuden, Endesa	Spain	El Bierzo	Oxy-fuel combustion, CFB	Coal	Pilot	30	2010
CARBFIX	Uni. Iceland	Iceland	Hellisheidi	CO <sub>2</sub> fixation by Basalt- pilot		Pilot	some tonnes/year	2010
ENEL HP-Oxy TCM-TECHNOLOGY CENTER MONSTAD	ENEL Gassnova, Statoil	Italy Norway	Bergen	Pressurised oxy-fuel combustion Post-combustion (solvent TBD)	Coal Gas	Pilot New	48	2012 2012

<i>Project name</i>	<i>Partners/ participants</i>	<i>Country</i>	<i>Location</i>	<i>Capture technology</i>	<i>Fuel type</i>	<i>New vs. repro</i>	<i>Plant size (MW)</i>	<i>Start up</i>
<b>America:</b>								
GCEP	STANFORD	USA		All three	All			2007
B&W	B&W	USA		Oxy-fuel combustion	Coal	Pilot	30	2008
Jupiter Pearl Plant		USA		Oxy-fuel combustion	Coal	Pilot	22 (EL)	2009
Mountaineer	AEP, ALSTOM	USA	West Virginia	Post-combustion, chilled ammonia	Coal	PILOT	20	2009
Pearl Plant		USA		Oxy-fuel combustion	Coal	PILOT	22 (EL)	2009
We Energies	We Energies, Alstom	USA	Wisconsin	Post-combustion	Coal	PILOT	1.7	2009
Saskatchewan-Montana Project	Uni. Regina/Montana	CND/US	Saskatchewan- Montana	Post-combustion Oxy-fuel combustion	Coal	demo		2011
Jamestown	Praxair	USA		CFB	Coal	Pilot	50	2013

<i>Project name</i>	<i>Partners/ participants</i>	<i>Country</i>	<i>Location</i>	<i>Capture technology</i>	<i>Fuel type</i>	<i>New vs. retro</i>	<i>Plant size (MW)</i>	<i>Start up</i>
<b>Asia:</b>								
Sumitomo capture	Sumitomo	Japan	Japan	Post-combustion	Gas		0.06	1994
Matsushima	MHI, JPOWER, RITE	Japan	Nagasaki	Post-combustion (KSI)	Coal	Pilot		2006
Gaobeidian Pilot	Huaneng	China	Beijing	IGCC - Pre-combustion	Coal	Pilot	<1	2008
EAGLE Project	NEDO, J-Power	Japan	Wakamatsu		Coal	Pilot	<1	2009
Shanghai Project	Huaneng	China	Shanghai	Post-combustion	Coal	Demo	Eq. To 20 MW coal power	2010
Youngdong		South Korea		Oxy-fuel combustion	Coal	Retrofit	100 (EL)	2016
YOUNGDONG		KOREA		Oxy-fuel combustion	Coal	RETRO	100 (EL)	2016
<b>Australia:</b>								
OTWAY	CO2CRC	AUSTRALIA	OTWAY	OTHER		NEW		2008
LVPCC (Latrobe Valley Post Combustion Capture Project)	CO2CRC, CSIRO	AUSTRALIA	Latrobe Valley	Post-combustion	Coal			2008
Mulgrave CCS trials	CO2CRC, HRL Developments	AUSTRALIA	Mulgrave	IGCC, pre-combustion, Oxy-fuel combustion, PC	Coal	PILOT	1	2009
Callide	CS ENERGY	Australia		Oxy-fuel combustion, PC	Coal	Retrofit	30	2010
Callide	CS ENERGY	AUSTRALIA		Oxy-fuel combustion, PC	Coal	retrofit	30	2010
ZEROGEN Phase 1	ZEROGEN	AUSTRALIA	Rockhampton	IGCC – pre-combustion	Coal	NEW	120	2012



# Appendix C4. Nordic CCS R&D projects and programmes

Name of project/ Programme	Host	Partners	Duration	Country	Area	Focus	R&D Budget (M€)	comment
"BIG" projects (CO <sub>2</sub> , CLC and H <sub>2</sub> )	SINTEF	NTNU, DLR (D), Cicero, UiO, Technical University of Munich, Research Council of Norway, Gassnova, Total, Aker Clean Carbon, Alstom, Shell, Statkraft, Statoil, General Electric, ConocoPhillips	2002–2011	Norway	R&D	Value chain	44	Strategic research umbrella made up by BIGCO1, BOGGCL, BIGH2
BIGCCS (Centre of Excellence)	SINTEF	Aker Clean Carbon, ConocoPhillips, DNV, Statoil, Shell, Cicero, Total, Schlumberger, Hydro, Statkraft, DLR (D), NGU, BGS (UK), Geos (DK), Resources for the future, Sandia National Laboratories, NTNU, UiO, Cicero, Technical University of Munich	2009–2016	Norway	R&D	Value chain	50	Constitutes one of 8 national Centres for Environment-friendly Energy Research (CEER)
CCS Slagnek- Knutegat (interreg project)	TellTek	Chalmers, Göteborgs Universitet, UiO, Telemarks Teknisk-industrielle Utdikningscenter	2010–?	Norway- Sweden- Denmark	R&D	Value chain	?	Funded by Telemarks Fylkeskommune, Vestfold Fylkeskommune, Innovasjon Norge, Västtra Östland Regionen, Energimyndigheten, Europeiska Regionutvecklingsfronden
SOLVti Programme	SINTEF	Aker Clean Carbon, NTNU, Scottish Power, Gassnova, Statkraft, Eon	2009–2017	Norway	R&D	Solvents	40	Aims at qualifying commercial absorption solvents (short term) including viable post-combustion systems based on absorption chemistry and adapted process design.

Name of project / Programme	Host	Partners	Duration	Country	Area	Focus	R&D Budget (M€)	comment
ECCSEL European CCS Lab Infrastructure	NTNU/SINTEF	University Center Svalbard (UNIS), University of Bergen, IFE, IRIS, Statoil, Aker Kvæmer, DLR Stuttgart, University of Stuttgart, ELGI (Hungary), ETH (CH), Polish Academy of Sciences, GEUS (DK), University of Zagreb, TNO, Technical University of Delft, IFP (F), MIT (USA), Tsinghua University, Shanghai Jiao Tong University, RITE & KJFEE (Japan)	2011---	Europe - World	R&D	European research infrastructure	81	23 M€ is Norwegian funding, the remaining is EU funding
CARBIFX	Uni. Iceland	Haskoli Islands, The Earth Institute (Columbia University), CNRS (F), Orkuveita Reykjavíkur	2010	Iceland	R&D	CO <sub>2</sub> fixation by Basalt-pilot	?	Hellshéidi. Imitating the natural storage process of CO <sub>2</sub> already observed in geothermal fields.
FLEXIBURN CFB		VTT, Endesa Generacion S.A., Fundación Ciudad de la Energía, Foster Wheeler Energia Oy, EDP - GESTAODA PRODUCAO DE ENERGIA SA, Poludniowy Koncern Energetyczny S.A., PRAXAIR NV, SIEMENS Energy, ADAPTIVE PREDICTIVE EXPERT CONTROL ADEX SL, UNIVERSIDAD DE ZARAGOZA, LAPPEENRANTA UNIVERSITY OF TECHNOLOGY, POLITECHNIKA CZESTOCHOWSKA, FOSTER WHEELER ENERGIJA S.A., ASOCIACION DE LA INVESTIGACION Y COOPERACION INDUSTRIAL DE ANDALUCIA "F. DE PAULA ROJAS"	2009-2012	Europe	RD&D	Oxy-fuel (CFB)		
CCS Suomi	VTT	VTT, Geological Survey of Finland, Tekes, Forum Oyj, Foster Wheeler Energia Oy, Metsä Oyj, Pohjolan Voima Oy, Rautaruukki Oyj, Vapo Oy	2007-2010	Finland	R&D	Application of CCS in Finland	1,4	
Clean CCS programme		Clean Oy, Tekes, VTT, ABB, Forum, Foster Wheeler Energia, Gasmot, Gasum Oy, Helsingin Energia, Metsä Power, Neste Oil Oyj, Nordkalk, Outotec Oyj, Rautaruukki Oyj, AF Consalt, Aalto University, Geological Survey of Finland, Lappeenanta Technical University, Tampere university, Tampere University of Technology, Finnish Environment Institute, Oulu University, Åbo Akademi	2010-2015	Finland	RD&D	CCS	22	
CARETECH	Åbo Akademi University	Åbo Akademi University, University of Turku, Aalto University	2008-2011	Finland	R&D	Mineral carbonation		

Name of project / Programme	Host	Partners	Duration	Country	Area	Focus	R&D Budget (M€)	comment
CCS in the Baltic region, phase I	Elforsk	Elforsk (Swedish Electrical Utilities' R&D Company), Swedish Energy Agency, Swedish industries, AF, IVL, U&W, Linköping University,	2009–2010	Sweden	R&D	CCS in the Baltic region	0.5	
System study and state-of-the-art CCS in the Baltic region	ÅF	ÅF, IVL, U&W, Linköping University, Elforsk (Swedish Electrical Utilities' R&D Company), Swedish Energy Agency, Swedish industries	2010	Sweden	R&D	Application of CCS in Sweden (and the Baltic region)	0.15	Pre-study within the above mentioned project (CCS in the Baltic region, phase I)
CLIPORE	IVL	CICERO, IVL, RFF, Linköping University, Göteborg University (for the CCS part of the project, several more for the rest of the project)	2007–2010	Sweden, Norway, USA	R&D	Focus on public acceptance		
CCS integrated with steel production	MEFOS	MEFOS, Swedish Energy Agency, LKAB, SSAB, Jernkontoret, IEA GHG R&D Programme	2009–2011	Sweden	R&D	Integration of CCS at steel production	0.14	
Carbon dioxide capture with two-stage-combustion for solid fuels	Chalmers Institute of Technology	Chalmers Institute of Technology, Swedish Energy Agency	2009–2013	Sweden	Research	Chemical Looping Combustion	0.56	Metal oxides as oxygen carriers in carbon capture with CLC.
Energy efficient oxy-fuel combustion and CO <sub>2</sub> capture in cement and lime industry	MinFo (Swedish Mineral Processing Research Association)	MinFo, Swedish Energy Agency, Umeå University, Cementa, Nordkalk, Cementa Research	2007–2010	Sweden	Research	Oxy-fuel combustion	0.45	





Series title, number and  
report code of publication

VTT Research Notes 2556  
VTT-TIED-2556

Author(s) Sebastian Teir, Jens Hetland, Erik Lindeberg, Asbjørn Torvanger, Katarina Buhr, Tiina Koljonen, Jenny Gode, Kristin Onarheim, Andreas Tjernshaugen, Antti Arasto, Marcus Liljeberg, Antti Lehtilä, Lauri Kujanpää & Matti Nieminen		
Title <b>Potential for carbon capture and storage (CCS) in the Nordic region</b>		
Abstract <p>The objective of this study is to give an overview of the potential for applying CCS in the Nordic countries (Sweden, Finland, Denmark, Norway and Iceland). The realistic potential of CCS in the region has been evaluated by taking into account existing and future energy systems and policies, emission sources, potential storage sites, technological, economical and political constraints as well as public acceptance. Special attention has been given to identifying promising regional CCS solutions that would have a significant CO<sub>2</sub> emission reduction potential and could possibly involve cooperation between Nordic countries with synergical benefits for these.</p> <p>The report includes mapping of CO<sub>2</sub> emissions in the Nordic countries from major sources, mapping and quantification of storage possibilities as well as scenarios of possible future CCS deployment in the region. In addition to the mapping, an overview of relevant CCS technology development and R&amp;D activities in the Nordic countries is given. Public awareness of CCS, energy and climate policy frameworks, as well as political issues relevant to the deployment of CCS in the Nordic countries are also addressed.</p>		
ISBN 978-951-38-7661-6 (soft back ed.) 978-951-38-7662-3 (URL: <a href="http://www.vtt.fi/publications/index.jsp">http://www.vtt.fi/publications/index.jsp</a> )		
Series title and ISSN VTT Tiedotteita – Research Notes 1235-0605 (soft back ed.) 1455-0865 (URL: <a href="http://www.vtt.fi/publications/index.jsp">http://www.vtt.fi/publications/index.jsp</a> )		Project number
Date October 2010	Language English	Pages 188 p. + app. 28 p.
Name of project		Commissioned by
Keywords CCS, Nordic countries, capture, storage, CO <sub>2</sub> , emission, infrastructure		Publisher VTT Technical Research Centre of Finland P.O. Box 1000, FI-02044 VTT, Finland Phone internat. +358 20 722 4520 Fax +358 20 722 4374



The objective of this study is to give an overview of the potential for applying CCS in the Nordic countries (Sweden, Finland, Denmark, Norway and Iceland). The realistic potential of CCS in the region has been evaluated by taking into account existing and future energy systems and policies, emission sources, potential storage sites, technological, economical and political constraints as well as public acceptance. Special attention has been given to identifying promising regional CCS solutions that would have a significant CO<sub>2</sub> emission reduction potential and could possibly involve cooperation between Nordic countries with synergical benefits for these.

The report includes mapping of CO<sub>2</sub> emissions in the Nordic countries from major sources, mapping and quantification of storage possibilities as well as scenarios of possible future CCS deployment in the region. In addition to the mapping, an overview of relevant CCS technology development and R&D activities in the Nordic countries is given. Public awareness of CCS, energy and climate policy frameworks, as well as political issues relevant to the deployment of CCS in the Nordic countries are also addressed.

ISBN 978-951-38-7661-6 (soft back ed.)  
ISSN 1235-0605 (soft back ed.)

ISBN 978-951-38-7662-3 (URL: <http://www.vtt.fi/publications/index.jsp>)  
ISSN 1455-0865 (URL: <http://www.vtt.fi/publications/index.jsp>)

