

## POTENTIAL FOR IMPROVED RELIABILITY AND REDUCED INTERRUPTION COSTS UTILIZING SMART GRID TECHNOLOGIES

Gerd H. KJØLLE  
SINTEF Energy Research – Norway  
gerd.kjolle@sintef.no

Vijay Venu VADLAMUDI  
NTNU – Norway  
vijay.vadlamudi@ntnu.no

Sigurd KVISTAD, Kjell A. TUTVEDT  
Hafslund Nett - Norway  
sigurd.kvistad@hafslund.no

### ABSTRACT

*This paper presents a reliability perspective of capturing the impact of individual smart grid technologies at the distribution level. A small case study on Hafslund Nett, the largest distribution network company in Norway, is presented to substantiate the hypothesis that by utilising SG technologies such as sensors and remote controlled sectionalisers together with global positioning systems, there is an increased scope for achieving a reduction in the frequency and duration of customer interruptions and the associated interruption costs.*

### INTRODUCTION

The reliability perspective of Smart Grids (SG), as in the case of conventional grids, begins with the question – ‘How can there be improvement in the reliability of the power system?’ In the context of traditional power systems, this concerns the investigation of redundancy arrangements. In SG, the effective utilisation of Information and Communication Technologies (ICT) could be a viable contributor in itself, besides improving the operational efficiency, consequently mitigating the need for extensive infrastructural expansion. Instrumentation such as sensors and smart metering and communication infrastructure form the backbone of ICT, enabling the improvement of failure diagnosis of the power system, and thereby the reliability.

In order to understand what kind of reliability metrics are needed to complement the existing ones on resource adequacy, an architectural composition from a reliability perspective was put forward in [1]. Further, reliability benefits of relevant SG technologies at various power system levels were identified in [2], where recommendations on use case-based approaches were also made for quantifying the reliability attributes of SG. Pilot projects based on incremental injection of ICT in the existing grids, which typically serve as use cases for performance analysis and benchmarking, could be utilised to investigate the economic consequences of SG investment for reliability improvement. Several such projects are currently being undertaken at the distribution level in Norway.

This paper uses a small Norwegian case study to substantiate the hypothesis that by utilizing certain SG technologies at the distribution level, there could be

increased scope for the reduction in frequency and duration of customer interruptions, and interruption costs.

### SMART GRIDS AND RELIABILITY

The basic measures of power system reliability, either with or without SG characteristic features, are the frequency and the duration of failure events. These measures subsequently form the basis for various other detailed metrics such as Loss of Load Probability (LOLP) or Energy Not Supplied (ENS). Reliability analysis at each of the generation and transmission system levels focuses on specific failure events of interest, e.g., load loss or network condition-related events such as line overloads and bus voltage violations. In so far as the distribution level is concerned, the focus is on customer interruptions. A majority of failures in the system are from the distribution end and their localised impact in the distribution system could be gauged through indices such as SAIFI and SAIDI, describing frequency and duration of customer interruptions, respectively [3].

Practitioners of SG philosophy have found it convenient to adopt a bottom-up approach of piecemeal introduction of relevant SG technologies at the distribution level. These include, in addition to distribution generation and storage facilities, demand response schemes and facilitation of advanced distributed automation services made possible by the deployment of sensors, advanced metering infrastructure, and strategic placement of intelligent protective and switching devices. Each of the SG technology constituents at the distribution level has its own reliability contribution, e.g., through a redundancy feature (as in the case of Distributed Generation (DG)), a resource mobilization characteristic (as in the case of Demand Response schemes (DR)) or a failure mitigation capability (as in the case of Advanced Distributed Automation (ADA)). An architectural composition from a reliability perspective [1], now tailored exclusively for the SG distribution system, is shown in the schematic in Figure 1, where DG, DR and ADA facilities are shown injected into the existing distribution grid. Their interplay is made possible by the intervening ICT constituents, which enable their successful integration into the system. The feedback control characteristic of ICT is what is crucial for the reliability improvement. It must however be pointed out that a comprehensive reliability analysis of the impact of simultaneous deployment of SG technologies at the

distribution level, is only possible with a top-down approach that can reveal the overall system impact of the various SG technology constituents.

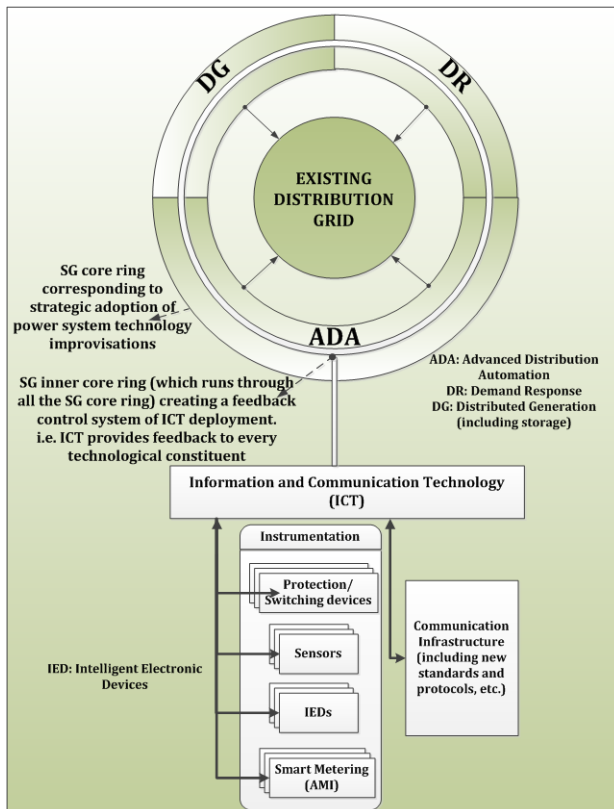

Figure 1 Distribution level SG reliability architecture

## RELIABILITY AND INTERRUPTION COSTS

The Norwegian Smart Grid Centre has listed the drivers for SG deployment in Norway [4], also citing the regulatory objective of minimising the overall socio-economic grid costs (of which interruption costs form a significant portion). Reliability worth assessment of the planned permeation of new SG technologies including ICT is thus indispensable. Penalty schemes and financial incentives like the Norwegian Cost of Energy Not Supplied (CENS) [5] arrangement provide the distribution network companies with incentives for reliability improvements in the development and operation of their networks. The CENS arrangement incorporates both notified and not-notified short ( $\leq 3$  min.) and long ( $> 3$  min.) interruptions resulting from planned outages and operational disruptions in electrical installations carrying voltages in excess of 1 kV [6]. This CENS-related figure is an expression of the total costs to the Norwegian economy incurred by end users in the event of interruptions. A reduction in its value upon the deployment of a particular SG technology is indicative of its reliability contribution. If any SG technology deployment contributes to reduced frequency and

duration of interruptions, it follows that there will be consequent reduction in the customer interruption costs. For example, in the USA, a new procedure to apply outage cost estimates to analyse the investment opportunity for SG technology constituents has been outlined in [7], and has been recommended for industry wide adoption to study the impact of SG technologies on reliability improvement.

According to the Norwegian interruption statistics for the ten-year period 2001-2010 [8], installations above 1 kV up to and including 22 kV contributed to 75 % of the total not-notified ENS (i.e., due to disturbances) while installations from 33 kV up to and including 420 kV contributed to the rest 25% of the total not-notified ENS.

## DEPLOYMENT OF SG TECHNOLOGIES IN HAFSLUND DISTRIBUTION NETWORK

One of the SG technologies currently being deployed for testing by Hafslund is the use of fault current sensors connected to SCADA by the use of Remote Terminal Units (RTUs). The placement of sensors and RTUs in various locations in the MV-grid is done to investigate the practical usability and the actual effects on reliability of supply in different types of networks (underground cable vs. overhead line, and combination). The sensors are expected to decrease the duration of fault localization and consequently the interruption duration, SAIDI, as well as ENS and CENS. Also, sensors which are capable of identifying the direction of earth faults in compensated MV grid are deployed. The RTUs are further connected to multifunction power meters providing measurements from the LV-side of the transformer, e.g., voltages, harmonic distortion, earth fault and transformer load and temperature through the established connection to SCADA. This enables better insight into the quality of supply for operation and planning purposes, and the possibility of faster response times during faults in the LV grid. Sensors are also expected to decrease the number of switching during faults, resulting in fewer short interruptions during sectioning and improved power quality in the network regarding voltage dips.

Based on analysis done on pilot studies at Hafslund, it is estimated that a full roll-out of fault current sensors at all MV/LV-substations (about 13,000) would decrease ENS and CENS for permanent faults by about 30%, which would be about 300 MWh and 10 million NOK (about 1.25 MEUR) yearly, respectively. In the case of deploying one sensor on an average for each feeder line, a scenario considered more realistic by Hafslund, it is estimated that ENS and CENS for permanent faults would decrease by about 5%, which would be about 50 MWh and 1.5 - 2 million NOK yearly, respectively. The cost of sensor technology and the income regulation scheme will play a decisive role when it comes to net profitability. However, for temporary faults no significant

reduction of ENS or CENS is expected, but increased knowledge of where the temporary faults are likely to occur would give a more efficient in-field inspection.

Selecting the best possible locations/substations for installation of fault sensors is considered by Hafslund to be a task requiring both insight into traditional reliability analysis and experience gained from the day-to-day operation of the grid by the control centre. The current method's primary indicator is chosen to be the total CENS of all customers connected to all substations on the feeder line under examination. In other words, the potentially most expensive feeder lines are the first to be investigated. In choosing sensor location(s) on the feeder lines, other factors come into play; CENS at each separate substation, availability of a multifunction power meter, ease of access to the substation and the number of switching done at each substation during faults are all the factors being considered in the analysis. In addition to these factors, significant focus is given to the topology of the feeder lines, where both single-line diagrams and the geographical representation of the grid are carefully analysed while keeping results from earlier reliability case studies in mind. The justification for each selection done is noted for future documentation.

Another method aiding in fault localisation currently being investigated by Hafslund is the use of the actual feeder line fault current in near real-time short circuit calculations to estimate the distance to the fault. A range of the already existing feeder line protection devices is expected to be able to provide the fault current value when tripping, which then can be transferred by the existing communication from the substations to be used immediately in calculations at the control centre by suitable software and network data for the actual grid.

Remote controlled sectionalisers have been in use in Hafslund's area for about 30 years, while Global Positioning Systems (GPS) have been in use for about 3 years. As the price of electronics and communication becomes less expensive, e.g., in conjunction with the future smart metering communication systems, it is reasonable to expect a significant increase in the deployment of remote control. GPS gives the control centre an overview of where available field crews are localised when a fault occurs. This makes it possible to deploy the field crew with the shortest estimated time of arrival and thus reduce the interruption duration.

## CASE STUDY

To illustrate potential for improved reliability and reductions in interruption costs, a small case study is presented. It is based on one of the pilot projects at Hafslund as referred to above and presented in [9]. The case deals with fault current sensors in the MV distribution network.

**Table 1 Reliability in example network, based on [9]**

Power line	Failure frequency (failures/year)	Interruption Duration DP A (hours)	Interruption Duration DP B (hours)	Interruption Duration DP C (hours)
A	$\lambda_A$	$\lambda_A \cdot R_A$	$\lambda_A \cdot R_A$	$\lambda_A \cdot R_A$
B	$\lambda_B$	$\lambda_B \cdot S_B$	$\lambda_B \cdot R_B$	$\lambda_B \cdot S_B$
C	$\lambda_C$	$\lambda_C \cdot S_C$	$\lambda_C \cdot S_C$	$\lambda_C \cdot R_C$

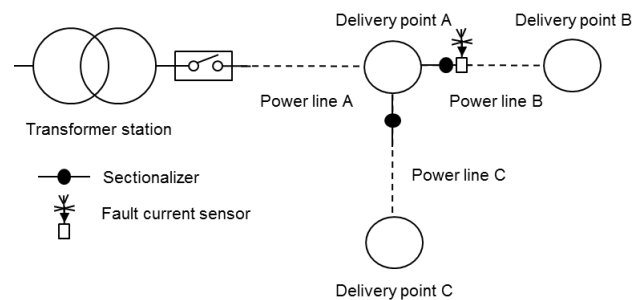

**Figure 2 Example MV network (based on [9])**

Consider the small example in Figure 2 showing three Delivery Points (DPs) and three MV power lines. The normal restoration procedure when there are no sensors or remote controlled sectionalisers present, is to send the restoration crew to the affected area (as indicated at the control centre) and perform manual switching until the fault is isolated between two sectionalisers. This procedure typically starts in the middle of the network. The accumulated time span for the fault localisation is defined as the sectioning time.

The reliability of supply of the example network with no sensors is analysed using the RELRAD methodology for distribution systems [10]. Of main interest is the interruption duration which might be influenced by the use of sensors. The results are given in Table 1 for the three delivery points. It is assumed that the repair starts immediately after the sectioning is finished. Total annual interruption duration for a delivery point is found by the summation of the contributions from failures on the three power lines. This is shown in Eqn. (1) for DP A.

$$U_A = \lambda_A \cdot R_A + \lambda_B \cdot S_B + \lambda_C \cdot S_C \quad (1)$$

where

$\lambda_i$  = Failure frequency for power line  $i$  (failures/year)

$S_i$  = Sectioning time for failure on line  $i$  (hours/failure)

$R_i$  = Sectioning time + repair time for line  $i$  (hours/failure)

$U_i$  = Annual interruption duration for DP  $i$  (hours/year)

Fault current sensors will in general decrease the duration of fault localisation. By sensing the fault current passing through, the sensor will indicate a failure downstream. As an example a sensor was installed just after delivery point A, i.e., before power line B in Figure 2. When a failure occurs in power line B, the sensor will indicate the fault current (visually) and send a signal to the SCADA system. The restoration crew can be sent directly to the

area downstream of the sensor. On the other hand, if a failure occurs and the sensor gives no indication, eventual failure in the downstream area can be eliminated and the crew can concentrate on the area upstream of the sensor. In this way all delivery points will benefit from reduced interruption duration using sensors.

The total reduction in interruption duration for all delivery points in a network is determined by the total number of failures sensed by the sensor times the corresponding reduction in the sectioning time for the faulty part. It is shown in [9] that the total saving in sectioning time can be found as given by Eqn. (2):

$$\Delta t_{s,tot} = \lambda_{indicated} \cdot \Delta t_{s,indicated} + \sum_i \lambda_{section\ i} \cdot \Delta t_{s,section\ i} \quad (2)$$

where

$\Delta t_{s,tot}$  = Total annual saved sectioning (and interruption) time (hours/year)

$\lambda_{indicated}$  = No. of failures in sensor-indicated network (failures/year)

$\Delta t_{s,indicated}$  = Reduced sectioning time for indicated network due to sensor (hours/failure)

$\lambda_{section\ i}$  = No. of failures in section i (not indicated by a sensor) (failures/year)

$\Delta t_{s,section\ i}$  = Reduced sectioning time for section i when a sensor indicates failure in another part of the network (hours/failure)

With the inclusion of the sensor (assumed 100 % reliable) in Figure 2, the results as shown in Table 2 are obtained for the interruption duration per delivery point.

The annual interruption duration (U) is again calculated by the summation of contributions from the 3 power lines to each delivery point (not shown here). By doing so, it is seen that U with sensor equals U without sensor, minus the total annual saved sectioning time from Eqn. (2):

$$U_{A\ sensor} = U_A - \Delta t_{s,tot} \quad (3)$$

Eqn. (3) gives the potential for decreased annual interruption duration for a delivery point. The most favourable location of the sensor will be where  $\Delta t_{s,tot}$  is maximised. The potential for reduced interruption cost ( $\Delta CENS$ ) can be found as follows:

$$\Delta CENS = \delta CENS / \delta r \cdot \Delta t_{s,tot} \quad (4)$$

where

$\Delta CENS$  = Reduction in annual interruption cost (NOK)

$\delta CENS / \delta r$  = Marginal CENS cost w.r.t. interruption duration (NOK/hour)

The marginal CENS cost can be found by deriving the cost functions, e.g. as given in [5]. This small example illustrates the approach for how to determine the potential improvements in reliability (here: interruption duration) and the corresponding reduction in interruption cost (CENS). Cost-benefit analyses described in [9] shows that the potential for improvements and profitability of installing sensors varies a lot between different types of MV networks. Depending on the number of sensors installed,  $\Delta t_{s,tot}$  typically varies in the order of 5 – 25 minutes and  $\Delta CENS$  in the order of a few percentages up to about 30 %, respectively.

**Table 2 Reliability with sensor as in Figure 2 [9]**

Power line	Failure frequency (failures/year)	Interruption Duration DP A (hours)	Interruption Duration DP B (hours)	Interruption Duration DP C (hours)
A	$\lambda_A$	$\lambda_A \cdot (R_A - \Delta t_{s,section\ A})$	$\lambda_A \cdot (R_A - \Delta t_{s,section\ A})$	$\lambda_A \cdot (R_A - \Delta t_{s,section\ A})$
B	$\lambda_B$	$\lambda_B \cdot (S_B - \Delta t_{s,indicated})$	$\lambda_B \cdot (R_B - \Delta t_{s,indicated})$	$\lambda_B \cdot (S_B - \Delta t_{s,indicated})$
C	$\lambda_C$	$\lambda_C \cdot (S_C - \Delta t_{s,section\ C})$	$\lambda_C \cdot (S_C - \Delta t_{s,section\ C})$	$\lambda_C \cdot (R_C - \Delta t_{s,section\ C})$

## CONCLUSIONS

A description of the SG technologies to be deployed in the Norwegian network company Hafslund's distribution network and the estimation of their impact on the reliability of supply for the end-users have been presented in this paper. The potential for improved reliability in terms of reductions in interruption duration and interruption costs upon the individual deployment of certain SG technologies has been studied. A methodology for the required reliability quantification has been proposed. Furthermore, the potential for cost savings was exemplified. Utilisation of these technologies changes the procedures for fault localisation and enhances failure mitigation, resulting in improved reliability and reduced interruption costs.

## REFERENCES

- [1] V. Vijay Venu *et al.*, 2012, "Challenges in smart grid reliability studies," *Proc. 12th Intl. Conf. Probabilistic Methods Applied to Power Sys.*, 1035-1040.
- [2] V. Vijay Venu, R. Karki, 2012, "Reliability-based appraisal of smart grid challenges and realization," *Proc. IEEE Power and Energy Society General Meeting*, 1-7.
- [3] R. Billinton, R. N. Allan, 1996, *Reliability Evaluation of Power Systems*, Plenum Press, New York.
- [4] D. E. Nordgård *et al.*, 2012, "Solutions from a national smart grid's demonstration site exploring a fiber-optic communication infrastructure," *Proc. IEEE Power and Energy Society General Meeting*, 1-5.
- [5] G. H. Kjølle *et al.*, 2008, "Customer costs related to interruptions and voltage problems: methodology and results," *IEEE Trans. Power Sys.*, vol. 23, no. 3, 1030-1038.
- [6] Norwegian Water Resources and Energy Directorate, 2012, *Annual Report 2011. The Norwegian Energy Regulator*, [www.nve.no](http://www.nve.no).
- [7] M. J. Sullivan *et al.*, 2010, "How to estimate the value of service reliability improvements," *Proc. IEEE Power and Energy Society General Meeting*, 1-5.
- [8] Norwegian Water Resources and Energy Directorate, 2011, *Avbruddsstatistikk (in Norwegian)*, [www.nve.no](http://www.nve.no).
- [9] K. A. Tutvedt, 2011, "Nytteverdi og potensialer for Smart Grid teknologi," (in Norwegian) *Masters thesis*, Norwegian University of Science and Technology (NTNU), Norway.
- [10] G. Kjølle, K. Sand, 1992, "RELRAD - an analytical approach for distribution system reliability assessment," *IEEE Trans. Power Del.*, vol. 7, no. 2, 809-814.