

THE INFLUENCE OF IMPEDANCE VALUES AND EXCITATION SYSTEM TUNING ON SYNCHRONOUS GENERATOR STABILITY IN DISTRIBUTION GRIDS

*Trond Toftevaag, Emil Johansson, Astrid Petterteig
SINTEF Energy Research
trond.toftevaag@sintef.no*

ABSTRACT

Synchronous machines installed in recently developed small-scale hydro power plants in Norway have relatively high values of the synchronous reactances, as well as the sub-transient and transient reactances. Typical synchronous reactance is 2 – 2.5 pu, but values up to 3.1 pu are experienced, which is 3 times the typical values for larger low-speed synchronous generators (with salient poles). High reactance in synchronous machines is a result of design, and is characteristic for machines with a small airgap, which again gives a cheaper machine.

In the present analysis, small-signal stability of a real life single-machine infinite bus system is studied for two different synchronous machine parameter value sets, one reflecting typical machine reactances and one with high reactance values. The analysis is performed in relation to active and reactive power production levels, and parameter settings for the automatic voltage regulator (AVR). The machine having “typical” parameters is small-signal stable for all situations studied. The stability of the machine with high reactance values, however, is strongly dependent of production level and AVR parameter settings. Stability margins and operation limits are given for the studied real life case. It is recommended that detailed power system analyses are performed, when the use of high reactance synchronous machines is considered, to ensure that stable operation can be obtained.

I. INTRODUCTION

Installation of small hydro power plants with a maximum rating of 10 MW has gained increased momentum in Norway during the last years. From 2001 to 2006, a total of 79 new small hydro plant was built in Norway. The Norwegian Water Resources and Energy Administration (NVE) gave in 2007 approval to 55 small power plants with a total electric power generation of 640 GWh. Several stability problems related to operation of new small hydro power plants in the medium voltage distribution network are reported during the last years. This applies to plants with a synchronous generator, and indications are that these problems are related to the control system.

This paper discuss in principle the relationship between synchronous machine and grid reactances, operating condition and parameter settings of the generator voltage control system from a stability point of view. Results from a computer based case study are given. The case is related to a recently opened hydro power plant where stability problems were experienced.

Chapter II gives a brief survey of different types of generally known electrically related stability problems. Chapter III gives a theoretical background to the presented stability problem. Chapter IV & V presents the case study where the influence of synchronous machine impedance values and excitation system is analysed. Discussion and conclusions are given in Chapters VI & VII, respectively.

II. SYNCHRONOUS MACHINE STABILITY

This chapter gives a brief overview of the power system stability problem, and will introduce the two classical stability phenomena well known from literature.

A necessary condition for satisfactory power system operation is that all synchronous machines remain in synchronism. Stability analysis is about the behaviour of the power system when subjected to a transient disturbance, either small or large, including identifying key factors that contribute to instability and devising methods of improving stable operation [5].

Power system stability may be broadly defined as follows [5]:

- The ability of an electric power system, for a given initial operating condition, to regain a state of operating equilibrium after being subjected to a physical disturbance, with most system variables bounded so that practically the entire system remains intact.

Rotor angle stability is the ability of interconnected synchronous machines of a power system to remain in synchronism after being subjected to a disturbance [1], [5].

The rotor angle stability problem involves the study of the electromechanical oscillations related to machine rotor speed variations (or rotor power angle variations), and which are inherent in power systems.

The readjustment process for the machine rotor following a (small) disturbance is always accompanied by a temporary change in the instantaneous mechanical speed (of the rotor) and a damped mechanical oscillation of the rotor (with accompanying power output and current pulsations) about its new steady-state torque (or power) angle. This type of oscillation is often called *hunting*. [4]

It is usual to characterize the rotor angle stability phenomena in terms of the following two categories: *Small-signal rotor angle stability* and *Transient stability*.

Small-signal rotor angle stability (or *small-disturbance stability*) is often defined as the ability of the power system to maintain synchronism when subjected to small disturbances [1], [5].

The disturbance is considered to be small in this context that equations that describe the system response may be linearized for the purpose of analysis. In today's interconnected power systems, the small-signal stability problem is usually related to insufficient damping of system

oscillations. Small-signal analysis (using linear techniques) provides valuable information about the inherent dynamic characteristics of the power system and assists in its design.

In relation to the typical single machine – infinite bus case the stability of the type of oscillations called *local modes* or *machine - system modes* is of main concern. The frequency of these oscillations is typical in the range of 1.0–2.5 Hz. Also the stability of control modes are of special interest in this context; usual causes of instability of these modes are poorly tuned exciters and speed governors. [1]

Transient stability or *large-disturbance rotor angle stability* is the ability of the power system to maintain synchronism when subjected to a severe transient disturbance. Usually the system is altered, so that the post-disturbance steady-state operation differs from that prior to the disturbance. [1]

Oscillations of the abovementioned type in a power system should in general be minimized by corrective measures. Some of the causes of *local plant mode* oscillations are [3]: regulator hunting, governor hunting and negative electrical damping (the so called inherent causes). (Cases of negative damping are now relatively rare). Also cases arise in which hunting may be produced by a combination of effects, but where it would not normally occur if these effects were individually applied. Regulator and governor hunting are normally kept to a minimum by proper design and tuning.

In the next section a troublesome case is studied, where hunting is produced by a combination of high (transmission line and/or generator) impedance, large power angle and certain parameter settings for the automatic voltage control system. Possibly a typical case of local plant mode oscillations.

III. THEORETICAL BACKGROUND

In this chapter a linearized model of a synchronous generator connected to an infinite bus through a transmission line, is presented. In this case linearization of the original nonlinear equations is appropriate, and valuable insight into the general behaviour of the system for different operating conditions can be gained by the techniques of linear systems analysis. Details about the development of this type of model for the case in question can be found in [1] and [2].

The following assumptions/conditions apply in this case:

- a simplified generator model is considered
- the power-angle relationship for the generator is expressed via the transient induced (internal) voltage E'
- the effect of field flux variations are included in the model
- the amortisseur effects are neglected
- an excitation system (linearized version) is included (consisting of the voltage transducer and AVR/Exciter blocks)

In this representation, the dynamic characteristics of the system are expressed via the linearization constants, the K-constants. The model is suitable to study general properties of the system, such as stability and damping of oscillatory modes. These properties depend on the location of the poles of the transfer functions.

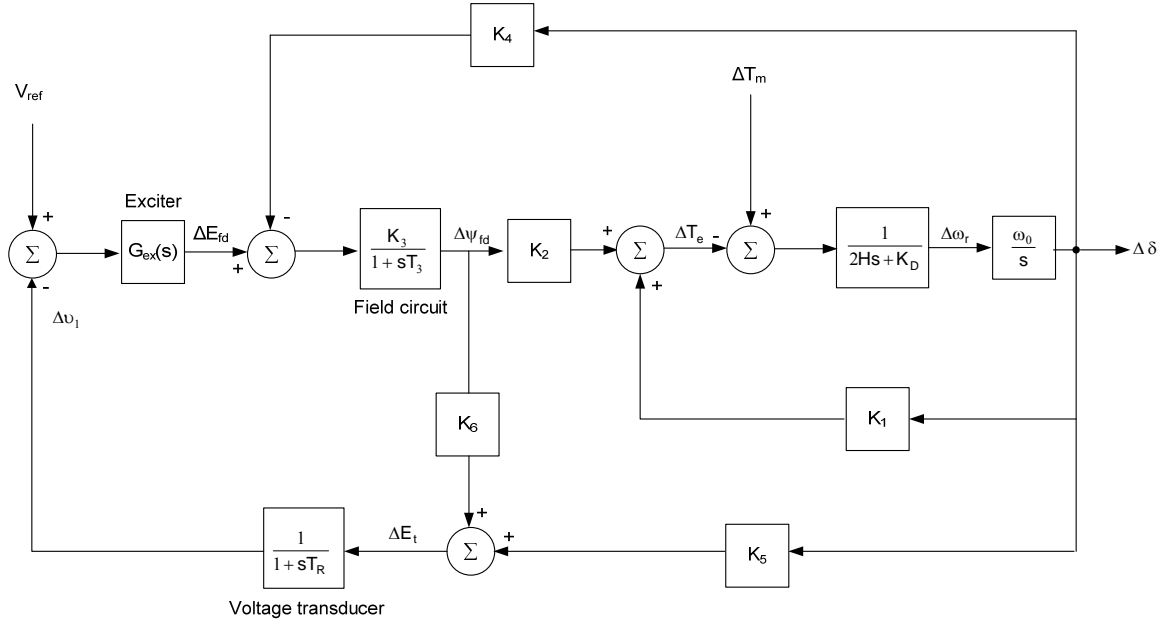

Figure 1 Block diagram representation of the small-signal (linearized) performance of the single generator – infinite bus system, including the excitation system. [1].

Figure 1 shows the complete block diagram for (the linearized model of) a generator connected through a transmission line to an infinite bus, including a voltage control system. The transfer function $G_{ex}(s)$ comprises both the regulator and the exciter. The diagram is based on a simplified generator model (shown in the right-hand part).

For the purpose of illustration, the transfer function of the excitation system model might be simplified by replacing $G_{ex}(s)$ by its dc gain, K_P (applies for a thyristor exciter).

Linearization constants K_4 , K_5 & K_6 are depending on the operating condition and system reactances, and are discussed further in the following. Further description can be found in [1], [2], & [3].

The coefficient K_4 is normally positive, and in this case the effect of field flux variation is to introduce a positive damping torque coefficient. In literature, situations are described where K_4 can be negative [1], [3]. The situation reported in [3], is when a hydraulic generator without damper windings is operating at light load and is connected by a line of relatively high R/X ratio to a large system. It seems reasonable to believe that these types of situations are now relatively rare. Under normal operating conditions K_6 is positive, whereas K_5 can be either positive or negative. This implies that the effect of the AVR on damping and synchronizing torque components primarily is influenced by K_5 and the exciter gain K_P .

The parameter K_5 can be determined via the following expression, where both the stator and line resistances are neglected, [2]:

$$K_5 = \frac{\partial |V_a|^0}{\partial \delta} = -|V_\infty|^0 \left(\frac{X'_d V_q^0}{(X'_d + X_s)|V_a|^0} \sin \delta^0 + \frac{X_q V_d^0}{(X_q + X_s)|V_a|^0} \cos \delta^0 \right)$$

Where:

- the superscript 0 refers to the evaluation of the partial derivatives, at the chosen steady-state operating condition.
- $|V_a|^0$ and $|V_\infty|^0$ are the terminal voltage of the generator bus and infinite bus, respectively.
- V_q^0 and V_d^0 are the generator bus voltage in rotor coordinates, and δ is the rotor angle (power angle) of the machine.
- X'_d , X_q and X_s , are the d -axis transient reactance, q -axis reactance, and external system reactance, respectively.

Under normal operation, V_q^0 is negative and for a generator V_d^0 is positive. This implies that, for a generator, K_5 is typically positive for low production and low values of external system reactance, and negative for high production and high values of external system reactances, [1] and [2].

Via reduction and further development of the block diagram in Figure 1, it can be shown that the closed loop transfer function from air-gap torque ΔT_e to the power angle $\Delta \delta$, due to change in field flux linkage $\Delta \psi_{fd}$, contains the term $(K_4(1 + sT_R) + K_5 G_{ex}(s))$. Or when assuming that $G_{ex}(s) = K_P$, and rearranging, the term becomes: $(K_4 + K_5 K_P + sK_4 T_R)$.

The common case when K_5 is negative is the troublesome case in this context. In this case the term $(K_4 + K_5 K_P)$ is frequently negative, causing the feed-back to change from positive to negative, and it can be expected that the system becomes unstable even with typical loop gains. It can further be shown [1] that when K_5 is negative, the effect of the AVR/exciter is to increase the synchronizing torque component and decrease the damping torque component. In many cases a high response exciter can be advantageous in increasing synchronizing torque, but with $K_5 < 0$ this introduces negative damping which creates conflicting requirements with regard to exciter response.

The above observations apply to any type of exciter with a steady-state exciter/AVR gain equal to K_P .

Will then a generator with relatively high reactance values have the same effect on the system as a long transmission line for high generator outputs? This question represents the motivation behind paper, and will be the subject for the investigations described in the following chapters.

IV. CASE STUDY MODEL

The case studies are made on a simple model consisting of a synchronous generator connected at the end of a radial distribution line, see single line diagram in Figure 2. The external grid is modelled by an infinite source and a short-circuit impedance. The test grid reflects the grid conditions of the real life case mentioned in the Introduction. This system is modelled and studied using the power systems simulation software SIMPOW®, [7].

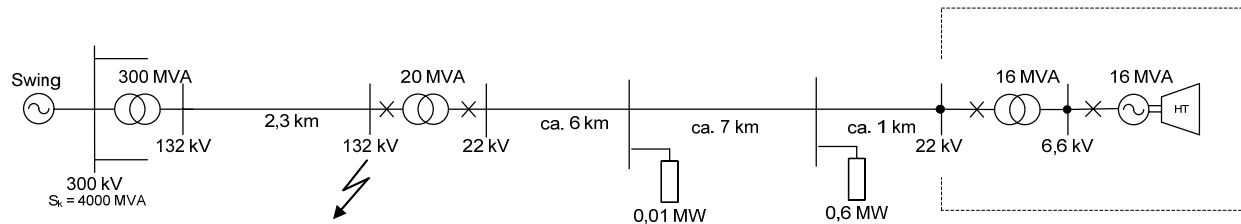

Figure 2 Single line diagram of simulation model

The synchronous machine is a salient pole machine with rated power of 16 MVA. Detailed synchronous machine models are used where: one field winding, one damper winding in d -axis and one damper winding in q -axis, and magnetic saturation is included (SIMPOW Synchronous machine model Type 2).

Machine design effects on system stability is studied by using two different machine models:

- Machine model 1 is a machine with extraordinary high reactances, with parameter values reflecting the machine in the real life case.
- Machine model 2 is a machine with more “typical” reactances for a synchronous machine applied in hydropower plants at this power level.

See machine parameters in Table A-3 (Appendix).

Table A-1, in Appendix, shows the reactances of the study system referred to the 6.6 kV generator bus level. For machine model 1, the dominating reactance is the synchronous machine direct-axis transient reactance (amounts to more than 60 % of the total reactance in the system).

The voltage regulator model are according to information from the AVR manufacturer, see Figure A-1 (Appendix). Recommended AVR settings for this PID regulator are determined by means of the software distributed by the AVR manufacturer [6]. Model and parameter settings are similar for both machine models see Table A-2 (Appendix).

Mechanical torque input from the turbine and governor is modelled either as a constant torque or as a ramp in the simulations. Further details of the model are given in Appendix.

V. CASE STUDY RESULT

The work is divided in linear and time domain studies, respectively, having the following study cases:

- Linear analysis
 - Machine models: 1 & 2
 - Operating point – Active power production: 7, 10, & 14 MW
 - Operating point – Reactive power: -2 Mvar (consumption) & 2 Mvar (production)
 - Regulator gain K_p : scanning 50-500

- Time domain analysis
 - Machine models: 1 & 2
 - Operating point – Active power production: 10MW & ramping 0-15 MW
 - Operating point – Reactive power: -2 Mvar (consumption) & 2 Mvar (production)
 - Regulator gain K_p : 120 & 250

Main emphasis is put on the behaviour of the machine model 1, reflecting the real machine of this case.

Linear analysis

In the linear analysis, it is focused on how different parameters (regulator settings, operating conditions, and machine models) influence on small-signal stability.

By eigenvalue analysis, the critical eigenvalues (related to the machine rotor oscillations) are identified. In the studied system the main oscillatory mode frequency is approximately 1.5 Hz (depending on operating conditions, though). This eigenvalue pair is in focus in the continuation of the linear analysis.

Figure 3 shows the root locus where the voltage regulator gain K_p is varied from 50 to 500 (recommended parameter value is 120). Only upper half-plane eigenvalue is shown.

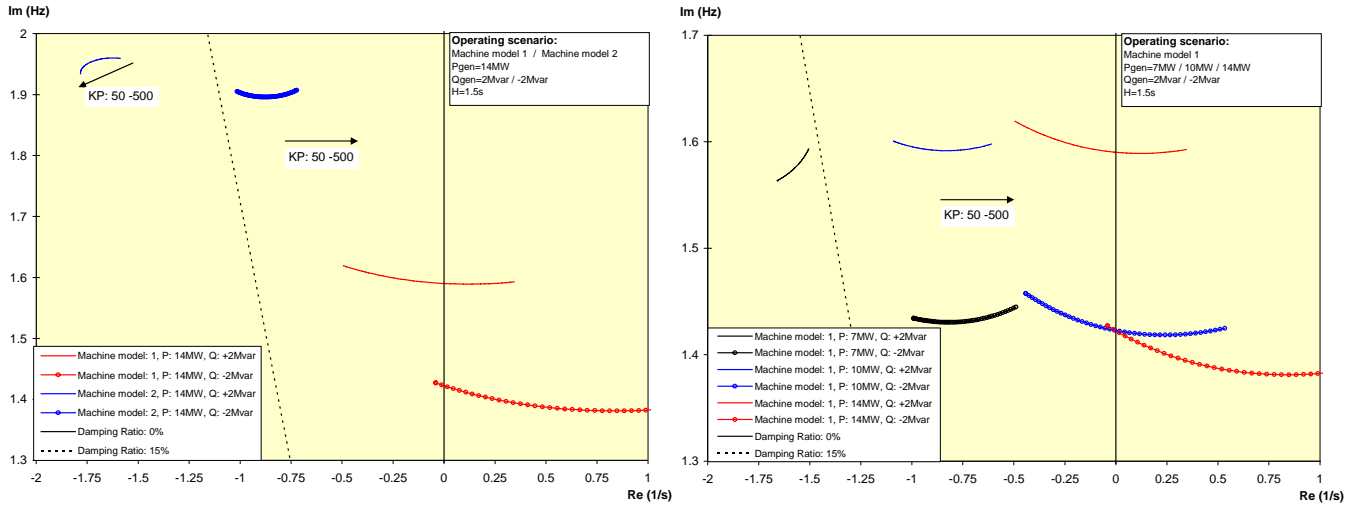

*Figure 3 Root locus plot. Regulator gain K_P scanning from 50 to 500, for reactive power production (2 Mvar) (thin lines) & consumption (-2 Mvar) (thick lines).
 Left-hand side: Machine model 1 (red) & Machine model 2 (blue), $P = 14$ MW
 Right-hand side: Machine model 1, $P = 7$ MW (black), 10 MW (blue), 14 MW (red)*

On the left-hand side of Figure 3 the machine models 1 and 2 are compared at a constant active power production $P = 14$ MW, and with reactive power production ($Q = 2$ Mvar) & consumption ($Q = -2$ Mvar). The operating conditions correspond to a power factor of approximately 0.99 (inductive / capacitive).

The right-hand side of Figure 3 shows the study results from machine model 1 for three different active power production scenarios ($P = 7, 10, \& 14$ MW), and with reactive power production ($Q = 2$ Mvar) & consumption ($Q = -2$ Mvar). The operating conditions correspond to a power factor of approximately 0.96, 0.98, & 0.99 (inductive / capacitive), respectively.

It is noticed that with machine model 1, the system becomes unstable with an increased regulator gain. At a reactive power consumption of 2 Mvar the system is unstable at a regulator gain even lower than the recommended model gain (at active power production 14 MW).

With a regulator gain of approximately 250, the system shows instability at the operating scenario with $P = 10$ MW & $Q = -2$ Mvar. We can assume that at a higher reactive power consumption (power factor < 0.96) the system will be unstable for even lower power production. The results show clearly that both active & reactive power have high impact on the stability; the higher the active production (or the higher the reactive consumption), the closer the system is to instability. It is also interesting to notice that machine model 2 shows an increased stability for higher regulator gain at the scenario with reactive power production.

Time-domain analysis

In the time-domain analysis, a ramping scenario and a fault scenario are studied.

In the ramping scenario, focus is on machine model 1. The active power is ramped from 0 to 15 MW. The voltage controller keeps the reactive power almost constant during the ramping. A slow ramping is applied – implying that the power-angle relationship is close to the steady-state characteristic.

In Figure 4 active power, reactive power, and rotor angle are shown for two reactive power scenarios: production ($Q = 2$ Mvar) & consumption ($Q = -2$ Mvar), respectively. The regulator gain is kept at the recommended level ($K_P = 120$).

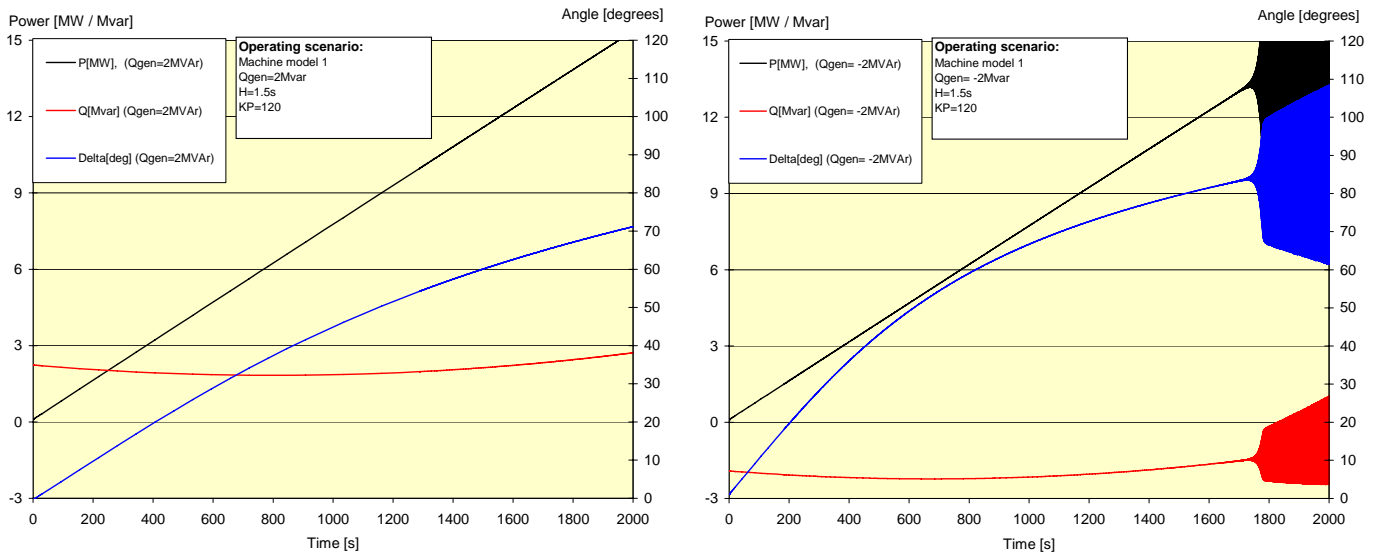

Figure 4 Active & reactive power, and rotor angle for active power ramping
 Left-hand side: $Q = 2$ Mvar (prod.), Right-hand side: $Q = -2$ Mvar (cons.)

In the case with reactive power consumption, instability occurs at around 13 – 14 MW. This level correlates well with expected level from the linear analysis (compare with Figure 3).

In the linear analysis it is observed that when increasing the regulator gain the system reaches an unstable state for lower active power production. This is also illustrated in Figure 5, where simulation results are presented for the case with reactive power consumption and regulator gain $K_P = 250$.

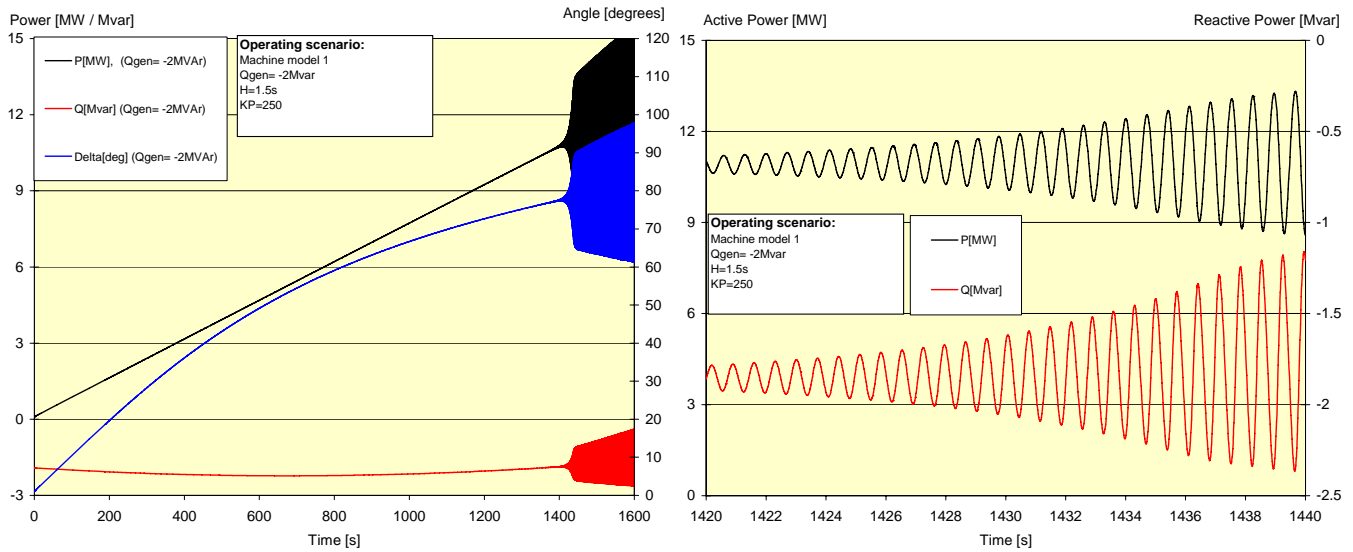

Figure 5 Active & reactive power, and rotor angle for active power ramping
Machine model 1, $Q = -2$ Mvar (consumption), $K_P = 250$

In the left part of the figure, the full ramp scenario is shown, and it is noticed that instability occurs around 10 - 11 MW (compared with 13 - 14 MW for $K_P = 120$). The right-hand side of the figure shows a zoomed-in view of the oscillations, where the oscillatory frequency is measured to approximately 1.5 Hz. Also these simulations correspond very well with the observations made in the linear analysis (compare with Figure 3).

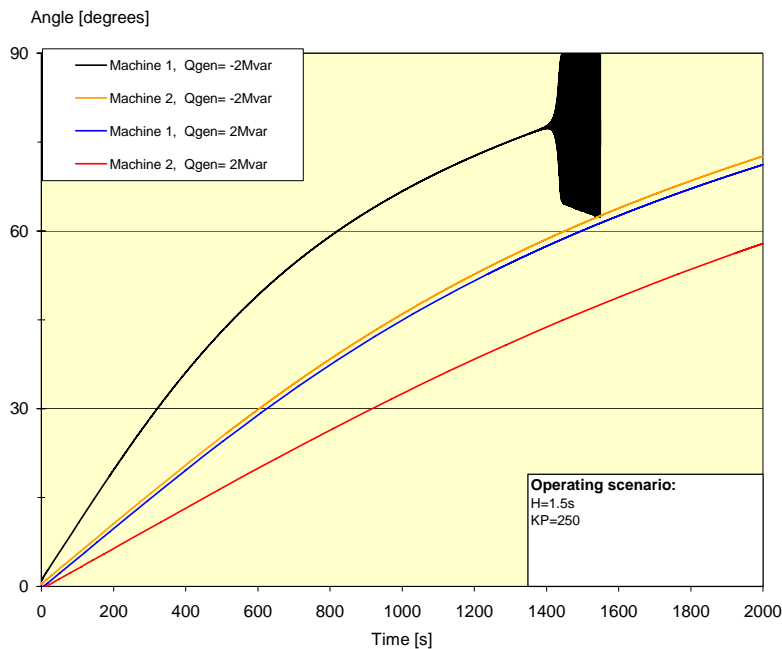

Figure 6 Rotor angle for active power ramping
Machine model 1, $Q = 2$ Mvar (production) & -2 Mvar (consumption), $K_P = 250$
Machine model 2, $Q = 2$ Mvar (production) & -2 Mvar (consumption), $K_P = 250$

In Figure 6, a comparison is made between the rotor angle of the two machine models when ramping the active power production from 0 to 15 MW, having a regulator gain $K_P = 250$, for both reactive power production and consumption.

Machine model 2 has a noticeable lower rotor angle, i.e. the stability margin of machine model 2 is higher than that of machine model 1.

In the fault scenario, a very short (20 ms) three-phase fault is simulated on the feeding line of the generator. The machine response is studied, and in Figure 7 the active power is shown for the two machine models. The operating scenario is: active power generation ($P = 10$ MW), and reactive power consumption ($Q = -2$ Mvar).

The result is similar to what the linear analysis and the ramping scenario shows, i.e. a significantly slower decay for machine model 1 than for machine model 2. Approximate oscillatory frequency and damping ratio for this case are listed in Table 1.

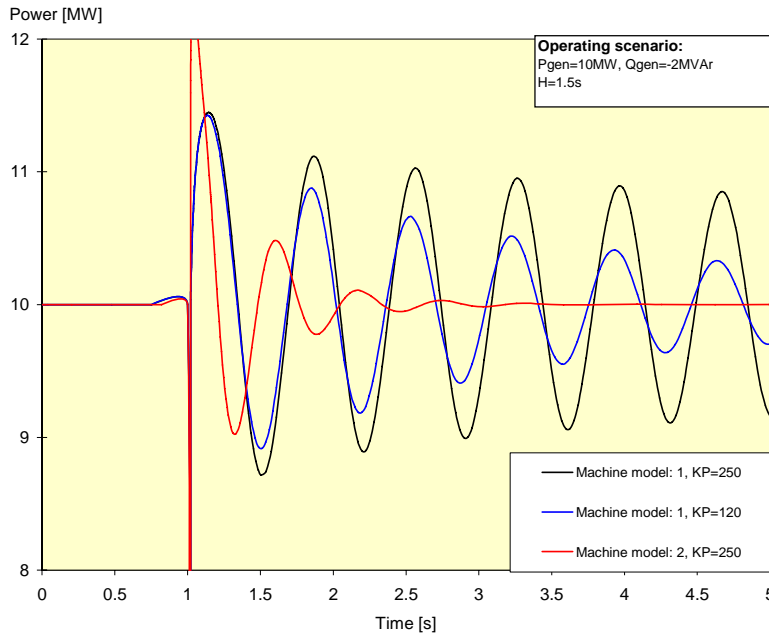

Figure 7 Active power oscillations after short circuit (20ms)
 Machine model 1, $P = 10$ MW, $Q = -2$ Mvar, $K_P = 120$ (blue) & $K_P = 250$ (black)
 Machine model 2, $P = 10$ MW, $Q = -2$ Mvar, $K_P = 250$ (red)

Table 1 Oscillation frequency and damping ratio, ref Figure 7

Machine model	Regulator gain K_P	Oscillatory freq. f [Hz]	Damping ratio ζ [%]
1	120	1.4	4%
1	250	1.5	1%
2	250	1.8	25%

VI. ANALYSIS AND DISCUSSION

From the linear analysis, the main observations (related to machine rotor oscillations) are:

- The system becomes unstable for machine model 1, with high active power production, when increasing the regulator gain
- The system becomes unstable for machine model 1, with reactive power consumption, even for recommended regulator settings

From the time-domain analysis, the main observations (related to machine rotor oscillations) are:

- Machine model 2 has a higher stability margin compared with machine model 1
- Machine model 1 shows a significantly slower transient decay than for machine model 2

The oscillatory frequency of the system is approximately 1.5 Hz (depending on operating conditions).

The following criteria for stable operation of the system are found, based on the results from the linear & time-domain analyses:

Table 2 Criteria for stable operation

Machine model	Q [Mvar]	P [MW]	K_p
1	+2 (prod.)	0-15MW	< 300
1	-2 (cons.)	0-13MW	< 120
1	-2 (cons.)	0-10MW	≤ 250
2	+/- 2	0-15MW	>>120 (limit not determined)

In practice, other factors might influence the stability criteria found in the simulations in a negative way. These factors can be related to e.g. penstock, turbine/governor, other hydrodynamic factors, as well as factors related to the external power system like switching of loads/lines/generation, etc. Therefore, it might be expected that the stability limit will be even lower than values shown in Table 2.

From the theory in Chapter III we know that: K_5 is typically negative for high generator outputs (large P_G) and high values of (external) system reactances. As K_5 is dependant on the power-angle, then also the excitation level will have a great impact in this context. An under-excited machine will have a larger power-angle than an over-excited machine, i.e. K_5 will be smaller (in some cases more negative) for the under-excited machine than for the over-excited machine, at the same active power production.

As further mentioned in Chapter III, the term $(K_4 + K_5K_p)$ is frequently negative and the system might become unstable even with typical loop gains. Case 2 in Table 2 represents an example of

this situation, where the system becomes unstable for a production lower than rated power at a AVR gain equal to the recommended value.

Machine model 2, which is a machine with “typical” reactances, does not show any stability problems, and has a large stability margin for the values of K_P that are studied both for the under-excited and over-excited scenario.

It seems reasonable to conclude that the K_P values given in Table 2 represents the limit levels for which the term $(K_4 + K_5K_P)$ becomes negative, and accordingly the system reaches instability.

Therefore we conclude that high (transient) machine reactances (which characterizes machine model 1) have the same effect as long transmission lines with respect to system stability.

If the stability problems cannot be avoided for this type of machine, the solution would be to implement a Power System Stabilizer (PSS) to enhance system stability. This will require that the machine is equipped with a classical exciter, i.e. an excitation system with brushes. Therefore a brushless excitation system would not be applicable in this case.

VII. CONCLUSIONS

In the presented analysis of a real life case it is shown that a synchronous machine with relatively high reactance values becomes unstable within the typical set of operation conditions, and for recommended AVR parameter settings. This is shown to be a result of a combination of control gain and high system reactances. In this case the high system reactances are represented by the synchronous machine reactances, rather than typically the transmission / distribution system reactances. Further, it is shown that it is possible to obtain stable operation by changing operating conditions, i.e. primarily by increasing reactive power production.

It is recommended that detailed power system analyses are performed, when the use of high reactance synchronous machines is considered, to ensure that stable operation can be obtained.

The use of a low-cost machine (like the high reactance machine) can soon be an expensive solution. For example, it might be necessary to install an external power system stabiliser (PSS) unit, which in worst case (for a brushless machine) requires a change of the complete rotor to in order to obtain the desired effect of the PSS.

VIII. REFERENCES

1. P. Kundur, *Power System Stability and Control*. McGraw-Hill, 1994.
2. Bergen, V. Vittal, *Power Systems Analysis*. Prentice Hall, 2000
3. S.B. Crary, *Power System Stability. Vol II*. John Wiley, 1947
4. Fitzgerald, Kingsley, Umans, *Electric Machinery*. McGraw-Hill, 1983.
5. P. Kundur, J. Paserba, V. Ajjarapu, G. Andersson, A. Bose, C. Canizares, N. Hatziargyriou, D. Hill, A. Stankovic, C. Taylor, T. Van Cutsem, and V. Vittal, *Definition and classification of power system stability IEEE/CIGRE joint task force on stability terms and definitions*, IEEE Transactions on Power Systems, vol. 19, no. 2, May 2004.
6. <http://www.basler.com/html/bestcoms.htm> – *BESTCOMS /DECS-100*, Software Tool for Settings of the digital excitation control system DECS-100, Basler Electric, 2007.
7. <http://www.simpow.com> – *SIMPOW Power System Simulation & Analysis Software*, STRI, 2007

IX. ACKNOWLEDGEMENTS

The results described in this paper have been obtained within the project “Distribution 2020” supported by The Norwegian Research Council, ABB and a group of Norwegian utilities and industry companies.

APPENDIX

Table of System Impedances

Table A-1 Summary of impedances in pu, ref. $U_B = 6,6 \text{ kV}$ and $S_B = 16,0 \text{ MVA}$

Component	Impedance		Comment
	R [pu]	X [pu]	
Generator, transient reactance	0.0122	0.662	Xd'
Transformer (22/6.6kV)	0.00469	0.080	
Cable (22kV)	0.0023	0.0051	
Line (22kV)	0.0304	0.1433	
Transformer (132/22kV)	0.0038	0.1042	
Line 132kV	0.0001	0.0008	
Transformer (300/132kV)	0.0001	0.0070	
Sum without generator	0.0391	0.3353	
Sum with generator	0.0513	0.9973	

Voltage Regulator data

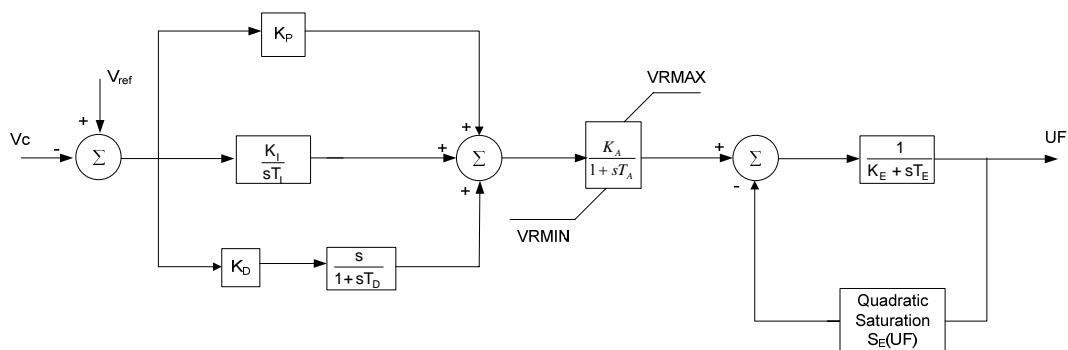

Figure A-1 Voltage regulator block diagram

Table A-2 Regulator parameter set

Parameter		Description	
K_P	[pu]	120,5	PID proportional gain
K_I	[pu]	165,5	PID integral gain
T_I	[s]	1	PID integral time constant
K_D	[pu]	25	PID derivative gain
T_D	[s]	0,01	PID derivative time constant
K_A	[pu]	1	Voltage regulator gain
T_A	[s]	0	Regulator time constant
V_{Rmax}	[pu]	35	Maximum regulator output
V_{Rmin}	[pu]	0	Minimum regulator output
K_E	[pu]	1,0	Exciter constant
T_E	[s]	0,5	Exciter time constant
S_{E1}	[pu]	1,346	Saturation curve value at point 1
E_1	[pu]	2,222	Voltage value at point 1
S_{E2}	[pu]	1,9	Saturation curve value at point 2
E_2	[pu]	2,962	Voltage value at point 2

The step response of the regulator is tested by applying a 0.05 pu step in the regulator voltage reference.

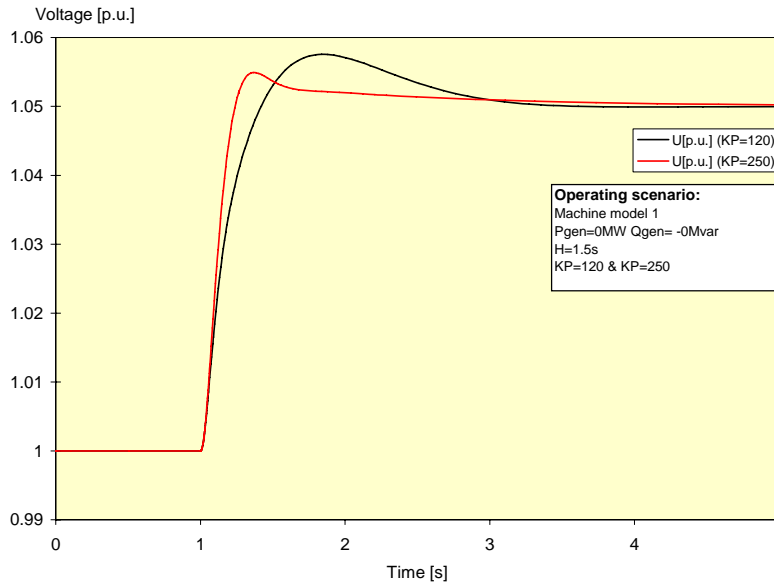

Figure A-2 Voltage regulator step response – Bus Voltage 0.05p.u. step in regulator reference (at time 0s)

The exciter saturation characteristic in the regulator is based on quadratic saturation, described by the following expressions:

$$S_E(UF) = \begin{cases} \frac{B(|UF| - A)^2}{|UF|} & |UF| \geq A \\ 0 & |UF| < A \end{cases}$$

With

$$A = \sqrt{E_1 E_2} \frac{\sqrt{E_1 S_{E2}} - \sqrt{E_2 S_{E1}}}{\sqrt{E_2 S_{E2}} - \sqrt{E_1 S_{E1}}}, \quad B = \frac{(\sqrt{E_2 S_{E2}} - \sqrt{E_1 S_{E1}})^2}{(E_2 - E_1)^2}$$

Parameters S_{E1} , E_1 , S_{E2} , and E_2 are approximated by two points on a saturation curve.

Synchronous machine data

The synchronous machine is modelled as a salient pole machine having basic data:

Sn: 16 MVA, Un: 6.6 kV, H: 0.836 s

Table A-3 Synchronous machine parameters

Parameter		Machine model 1	Machine model 2	Description
X_d	[pu]	3.1	2.04	d-axis synchronous reactance
X_d'	[pu]	0.662	0.238	d-axis transient reactance
X_d''	[pu]	0.389	0.143	d-axis subtransient reactance
X_q	[pu]	2.02	1.16	q-axis sync. reactance
X_q''	[pu]	0.377	0.137	q-axis subtr. reactance
r_a	[pu]	0.0122	0.00219	Armature resistance
X_l	[pu]	0.25	0.13	Leakage reactance
T_{d0}'	[s]	4.85	2.38	d-axis open-circuit tr. time const.
T_{d0}''	[s]	0.0306	0.0117	d-axis open-circuit subtr. time c.
T_{q0}''	[s]	0.1715	0.11	q-axis open-circuit subtr. time const.
H	[s]	0.836	0.836	Inertia constant
V1D	[pu]	1.0	1.0	d-axis air-gap flux corresp. to SE1D
SE1D	[pu]	0.1	0.1	Saturation factor corresp. to V1D
V2D	[pu]	1.2	1.2	d-axis air-gap flux corresp. to SE2D
SE2D	[pu]	0.3	0.3	Saturation factor corresp. to V2D

System data

In the model, an inertia constant of the total generator system is used, reflecting the total inertia of the generator, exciter, turbine, and shaft. This total value is assumed as 1.5 s (the generator inertia constant being 0.836 s).

Total line length between the infinite bus and the generator bus is approximately 15 km, and there are three transformers included in the model, as can be seen in the single line diagram. Rating and impedances of lines and transformers are corresponding to the actual case, and the reactances can be found in the table of system reactances.

Short-circuit level of the external grid is assumed to 3 GVA, inductive.