

# EVALUATION OF SIMPLE FAULT LOCATION ON A MV FEEDER WITH DG, USING FUNDAMENTAL FREQUENCY COMPONENTS

Jorun Marvik  
NTNU, Norway  
Jorun.Marvik  
@elkraft.ntnu.no

Hans Kristian Høidalen  
NTNU, Norway  
Hans.Hoidalen  
@elkraft.ntnu.no

Astrid Petterteig  
SINTEF, Norway  
Astrid.Petterteig  
@sintef.no

*Abstract – This paper looks into possibilities for locating short circuit faults on a MV feeder with distributed generation (DG). Power frequency measurements of voltages and currents are utilized for estimating the distance to the fault location. Loads and infeed current from generators connected to the feeder induce errors in the estimated distance. In the paper, methods to compensate for these errors are investigated. The goal is good enough fault location with limited information from the feeder. To be able to compensate for DG-infeed during various load conditions, measurements in the DG-node is necessary, in addition to the substation measurements. DG-node measurements are also utilized for discriminating between faults on the main and on a lateral branch. The paper is based on simulations and analytical calculations.*

## 1 INTRODUCTION

The amount of distributed generation (DG) is increasing, introducing some new challenges regarding the operation of distribution networks. In Norway, a lot of small hydro power plants are built. Usually, the plants are located in rural areas, and are connected to distribution networks. Commonly, the distribution networks in these areas are weak. At the same time, there is an increased focus on power quality, with intensified regulations and penalties for non-supplied energy. Fast and efficient fault handling is becoming more important, and one way of achieving it is through automated fault location. Today, sectioning of faults in distribution networks is time consuming. Remote control of breakers is however becoming more common. Much literature is found on the topic fault location in distribution networks without distributed generation, using power frequency measurements from only one terminal (the substation). The challenge is then to minimize the impact from load and fault resistance. Good results are reported, utilizing pre-fault substation measurements in the compensation of load [1]-[3]. Lethonen et. al. [4] presents a method for estimating the distance to the fault by comparing the measured and the calculated fault current. In addition, information from fault locators in the branching points and knowledge of fault frequencies of different line sections are utilized. There are also papers treating distribution networks with DG [5]. Advanced methods based on fault transients, adaptive protection schemes or relay agents are presented in e.g. [7]-[9].

The purpose of this paper is to find a relatively simple method for sufficiently accurate fault location on a distribution feeder with DG, with limited information available. Generally, the load level of each distribution transformer at a certain time is not known, only their locations and ratings. The same is true for DG units connected to the feeder. First, for comparison, the case with only substation measurements available is considered. Subsequently, measurements in the DG-node are utilized in addition to the substation meas-

urements. Finally, the DG-node measurements are utilized for discriminating between faults on the main and on a lateral branch.

## 2 SIMULATED NETWORK

A simple medium voltage (MV) feeder with DG, shown in Figure 1, is modeled in PSCAD/EMTDC. Only three phase short circuit faults are considered.

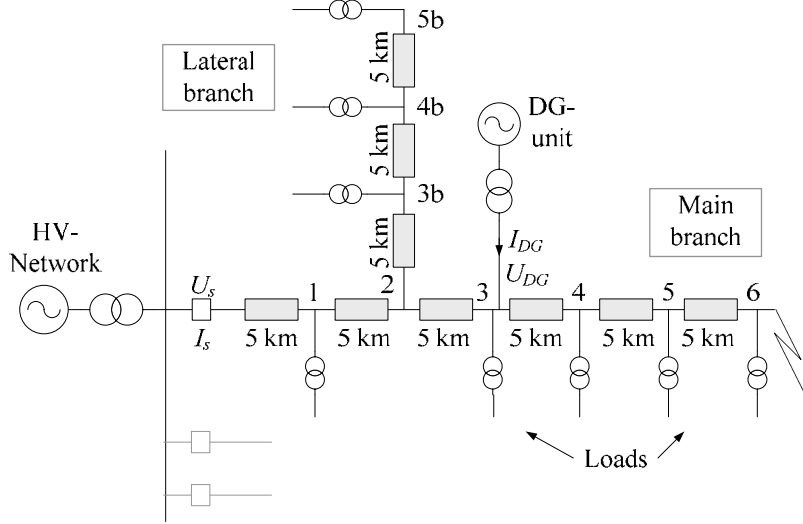

Figure 1: Radial feeder with DG

$U_s, I_s$ : Feeder voltage and current measured in the substation during fault.

$U_{DG}, I_{DG}$ : Voltage and in-feed current in DG-node during fault.

Index 0: Identifies pre-fault quantities, e.g.  $U_{s,0}$  means pre-fault substation voltage.

Each line section is 5 km.

$d_E$ : distance from the substation to the feeder-end, equal to 30 km.

$d_{DG}$ : distance from substation to DG-node.

$d_X$ : estimated distance to fault location, based on substation current and voltage

Loads are modeled using standard static load models [10] :

$$S = P + jQ = P_0 \left( \frac{|U|}{|U_0|} \right)^{N_P} + jQ_0 \left( \frac{|U|}{|U_0|} \right)^{N_Q} \quad (1)$$

$S, P, Q$ : apparent, active and reactive power of the load

$N_P$ : voltage dependency factor of active power, set equal to 1 (constant current characteristics)

$N_Q$ : voltage dependency factor of reactive power, set equal to 2 (constant impedance characteristics)

The load is evenly distributed. High load for the feeder is 6 MVA, and low load is 1.5 MVA. The pre-fault power factor of the loads is 0.9.

The DG is producing 3 MW at a power factor of 1. It is modeled as a synchronous generator, since it is the most common generator type in small hydro power plants.

Simulated voltages and currents are converted to phasors using the Fast Fourier Transform. The values denoted as “during fault” are read 2 periods (50 Hz) after fault inception. This corresponds to the transient part of the short circuit response of a synchronous machine. The size of the generator transient short circuit current depends on how close to the DG-node the fault is. For the simulated cases it varies from  $\sim 2 - 4$  times the pre-fault current.

### 3 DISTANCE ESTIMATION BASED ON IMPEDANCE

Distance protection responds to the impedance between the measuring point and the fault location. If the line impedance per unit of length is known, the distance to the fault location can be calculated. Generally, this impedance is not constant for the whole distribution feeder. This complicates the fault distance computation to some degree. To avoid impact from the fault resistance, which is unknown, the distance is usually calculated from the reactance part of the impedance. The distance estimate obtained from the substation voltage and current equals:

$$d_x = \frac{\text{Imag}(U_s/I_s)[\Omega]}{X_{line}[\Omega/km]} \quad (2)$$

Errors due to load and DG are introduced in the distance estimate. The effect of having DG in the network is that  $d_x$  becomes larger than the real distance to the fault location. The effect of load is opposite. This means that the impact from DG to some extent is counterbalanced by the load.

### 4 COMPENSATION UTILIZING PRE-FAULT SUBSTATION MEASUREMENTS

A first attempt in taking the load and DG-infeed into account is to utilize the measured pre-fault substation current, and assume that it corresponds to one equivalent load including both passive loads and generation. Taking the voltage dependency of this equivalent load into account, a compensation current can be calculated. This current is subtracted from the measured substation current during fault, to improve the fault distance estimate, as shown in eq. (4).

The static model in eq. (1) is used for estimating the power flow to the equivalent load,  $S_{L+DG}$ . The static load model is not very suitable for representing the synchronous generator, but is used in absence of a better model. Since the relative portions of load and DG are unknown, it is difficult to decide the values of the factors  $N_P$  and  $N_Q$ .  $N_P = 1$  and  $N_Q = 2$  are used here.

$$S_{L+DG} = \frac{d_x}{2 \cdot d_E} \cdot \left( P_{S,0} \left( \frac{|U_s|}{|U_{S,0}|} \right)^{N_P} + jQ_{S,0} \left( \frac{|U_s|}{|U_{S,0}|} \right)^{N_Q} \right) \quad (3)$$

The estimate  $d_x$  is used because only loads connected before the fault location should be compensated for. In eq. (3) only the change of the substation voltage magnitude is included, and this is where the change of magnitude is smallest during a fault, especially for a fault far from the substation. To account for the declining voltage profile from the substation towards the fault, the voltage magnitude  $|U_s|$  is divided by 2. The shape of the voltage profile depends on the location and generation level of the DG, so to divide by 2 is just a guess. All the mentioned factors add uncertainty to this compensation method.

The impedance to the fault location after compensation,  $Z_{comp,1}$ , becomes:

$$Z_{comp,1} = \frac{U_s}{I_s - I_{L+DG}} = \frac{|U_s|^2}{(S_s - S_{L+DG})^*} \quad (4)$$

A new fault distance  $d_{comp,1}$  is estimated from the impedance  $Z_{comp,1}$ :

$$d_{comp,1} = \frac{\text{Imag}(Z_{comp,1})}{X_{line}} \quad (5)$$

The described method is similar to the one described in [1], for networks without DG. Figure 2 shows the error in the calculated distance in percent for different fault locations, when the DG is located 15 km from the substation, and the short circuit current is compensated according to eq. (4). Distance estimate error in percent is on the vertical axis. This error

is equal to the difference between estimated and real distance to the fault location, divided by the total length of the feeder. A positive distance estimate error thus means that the estimated distance is too large.

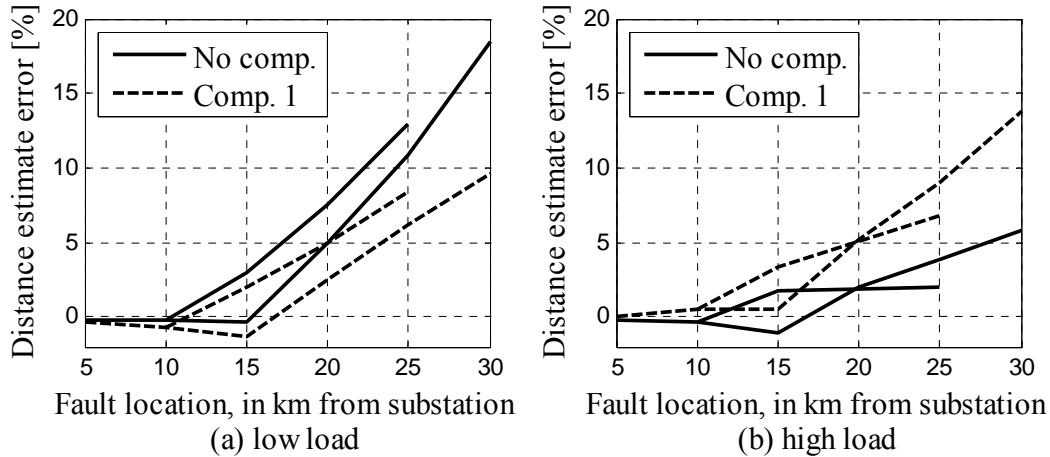

Figure 2: Distance estimate error for various fault locations, with the DG connected 15 km from the substation. (a) Low load case. (b) High load case.

The two curves in Figure 2 that stops at 25 km correspond to faults on the lateral, while the other two correspond to faults on the main branch. Without any compensation, the errors in the distance estimate is largest for the low load case. The error seen with faults on the lateral branch is due to infeed from the DG located on the remote side of the branching point. With a fault after the DG-node, on the main branch, an error is introduced due to the fault-current contribution from the DG. With compensation, the error is reduced in the low load case, while it is increased in the high load case.

Figure 3 shows how the location of the DG impact on the distance error. Here, the fault location is 25 km from the substation on the main branch, while the location of the DG is varied.

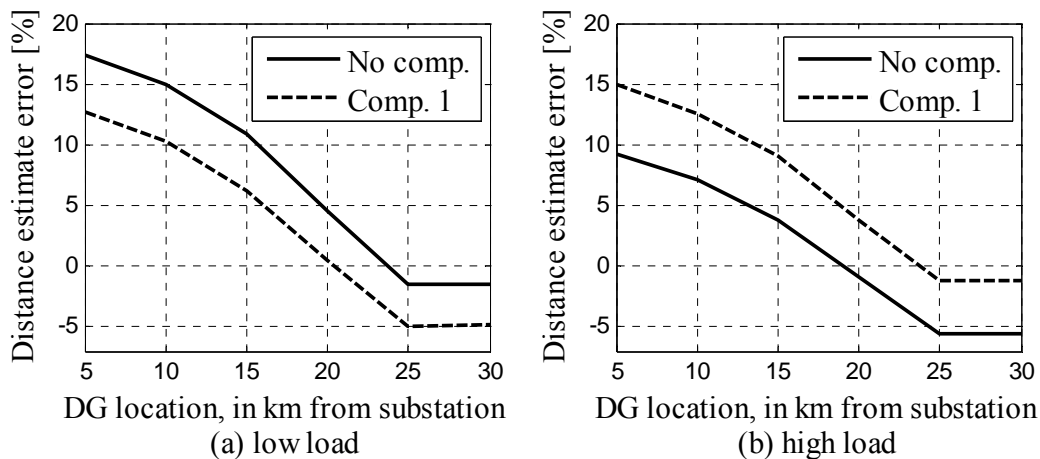

Figure 3: Distance estimate error for a fault 25 km from the substation on the main branch, for various DG locations. (a) Low load case. (b) High load case.

Figure 3 shows that the distance estimate error is largest with the DG close to the substation. Whether the error is reduced or increased with compensation depends on the location of the DG-unit. The values read for DG location 15 km from the substation in Figure 3 corresponds to a fault 25 km from the substation in Figure 2.

This compensation method does not give a good result for the high load case. In this case the load is larger than the DG-infeed before the fault occurrence, and the current flowing from the substation to the feeder is positive. When a short-circuit occurs the DG-current increases, while the load current decreases and becomes smaller than the DG-current. The resultant substation current thus changes sign, and this is not handled by this compensation method.

## 5 COMPENSATION UTILIZING PRE-FAULT DG-NODE MEASUREMENTS

In this chapter, pre-fault absolute values of DG current and voltage and DG phase angle are assumed to be known from measurements. Then the total pre-fault load can be calculated. The apparent power of the load and the DG during fault is calculated separately, using expressions similar to that given in eq. (3).  $N_P$  for the DG is set to 0 (constant power characteristics). Again, this is not a very good representation of the DG, and will not give an accurate result. The DG-infeed current is only compensated for if the fault, according to the estimate from eq. (2) appears to be after the DG node.

$$Z_{comp.2} = \frac{U_s}{I_s - I_L + I_{DG}} = \frac{|U_s|^2}{(S_s - S_L + S_{DG})^*} \quad (6)$$

The results using this compensation are shown in Figure 4 and Figure 5.

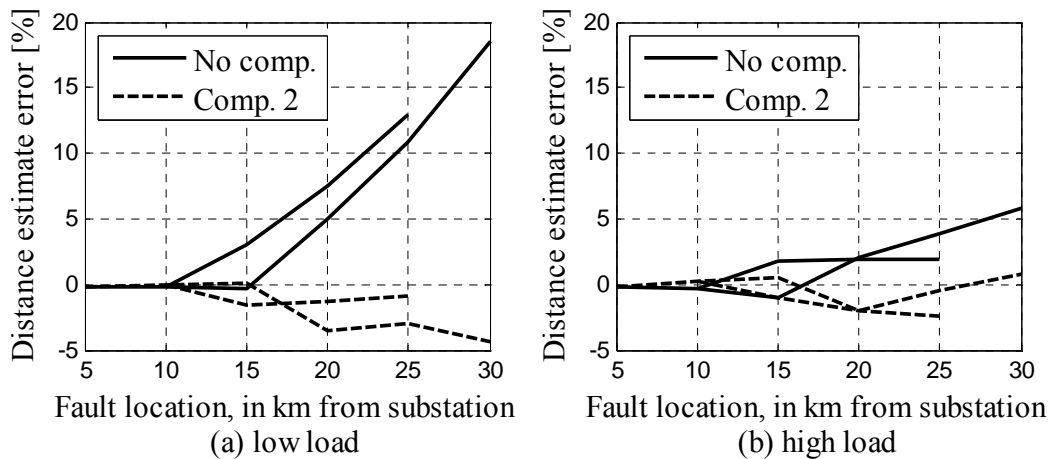

Figure 4: Distance estimate error for various fault locations, with the DG connected 15 km from the substation. (a) Low load case. (b) High load case.

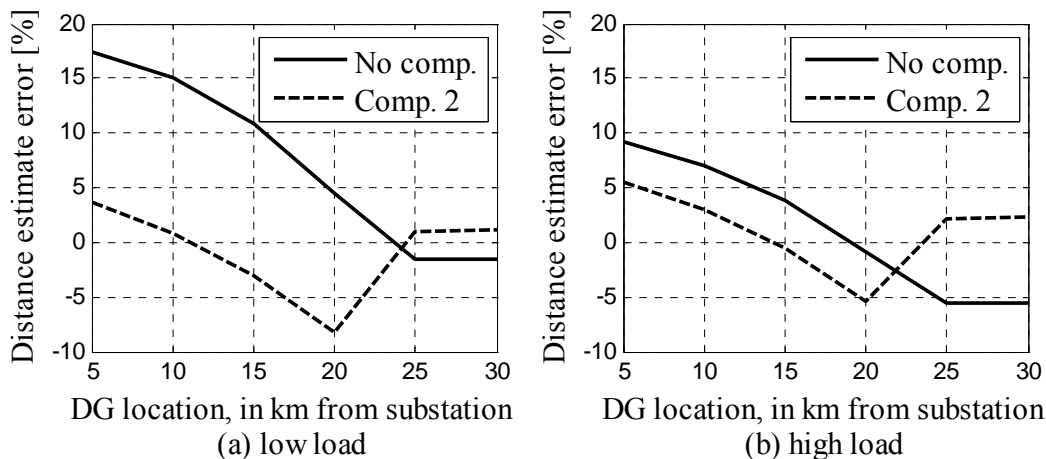

Figure 5: Distance estimate error for a fault 25 km from the substation on the main branch, for various DG locations. (a) Low load case. (b) High load case.

The result is much better than with the previous compensation method based on substation measurements only (comp. 1). Thus it is very advantageous to know the pre-fault power-flow of the DG-unit. The "jump" in the curves with compensation in Figure 5 is because the DG-infeed is compensated for when the DG is located 20 km from the substation (fault location after DG-node), but not when the DG is located at 25 km (fault location before/at DG-node).

## 6 LOAD ESTIMATION UTILIZING PRE-FAULT DG-NODE MEASUREMENTS

With an analytical model of the network, a more accurate compensation for load and DG-current can be achieved. One way of including loads in an analytical model is to represent the line as a pi-equivalent with loads as shunt impedances. This implies evenly distributed loads. It is assumed that pre-fault absolute values of DG current and voltage, and the power factor of the DG-unit, are available.

Figure 6 shows an equivalent circuit of the feeder, with loads included as impedances in a pi-equivalent, for the pre-fault state. The feeder is split into two parts, representing the section before and after the DG-node, respectively. Loads on laterals are included in the total load of the section.

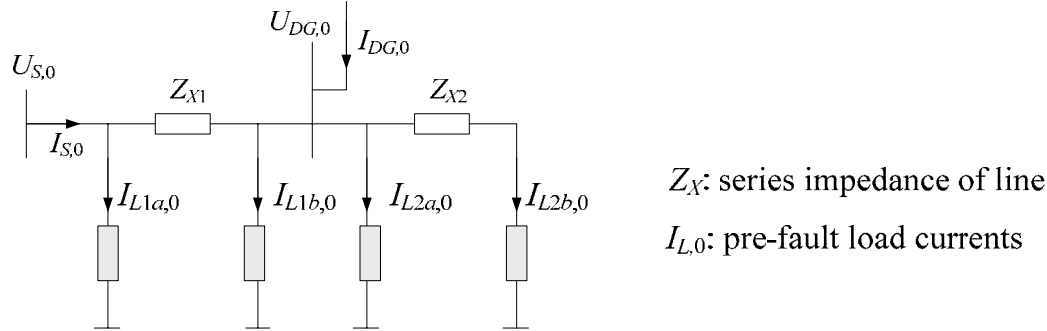

Figure 6: Equivalent circuit of feeder before fault occurrence

Using the following expression, the power flowing to the load connected in the substation in Figure 6,  $S_{L1a,0}$ , can be calculated:

$$U_{DG,0} = U_{S,0} - Z_{X1} \left( I_{S,0} - \frac{S_{L1a,0}^*}{U_{S,0}} \right) \quad (7)$$

Eq. (7) can be rewritten to the following second order equation:

$$|S_{L1a,0}|^2 + (k_1 + k_1^*) |S_{L1a,0}| + k_1 k_1^* - \left( \frac{|U_{DG,0}| |U_{S,0}|}{|Z_{X1}|} \right)^2 = 0, \quad k_1 = \left( \frac{|U_{S,0}|^2}{Z_{X1}} - I_{S,0} U_{S,0}^* \right) \angle S_L \quad (8)$$

In order to find the unknown  $S_{L1a,0}$ , the power factor of the load has to be known. All loads are assumed to have the same power factor.

When  $S_{L1a,0}$  is calculated, the power-flow to the load connected in the DG-node,  $S_{L1b,0}$ , can also be found:

$$S_{L1b,0} = \frac{|U_{DG,0}|^2}{Z_{L1,0}^*} = S_{L1a,0} \frac{|U_{DG,0}|^2}{|U_{S,0}|^2} \quad (9)$$

Finally, the pre-fault load of the section behind the DG-node,  $S_{L2,0}$ , can be calculated:

$$S_{L2,0} = S_{L2a,0} + S_{L2b,0} = S_{S,0} + S_{DG,0} - S_{L1,0} \quad (10)$$

Here, the series impedance of the line section after the DG-node is neglected, since it is assumed to be much smaller than the load impedance.

## 7 COMPENSATION UTILIZING DG-NODE MEASUREMENTS DURING FAULT

In this chapter, measurements from the DG-unit also during fault are assumed to be available. The DG-node measurements do not need to be synchronized with the substation measurements, since only absolute values and the angle between the DG voltage and current are required. Some method for deciding whether the fault is located before or after the DG-node is necessary, e.g the method described in chapter 8.

### 7.1 Fault in front of the DG-node

If the fault is assumed to be located before the DG-node, the first section is split into two new parts; one before and one after the estimated fault point given by  $d_x$  in eq. (2).

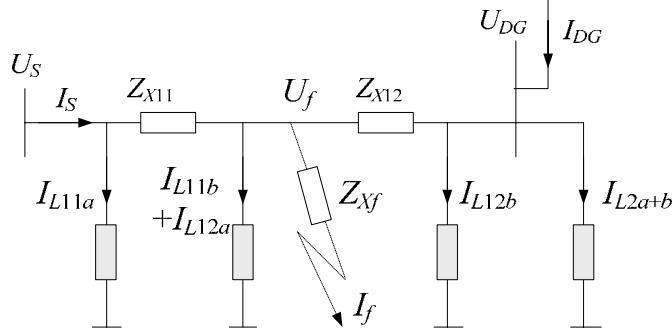

Figure 7: Equivalent circuit of feeder for a fault located before the DG-node

The fault can also be located on a side branch. Then, the point  $f$  is where the lateral is connected to the main line, and  $Z_{Xf}$  represents the impedance from the branch point to the fault. The voltage in the assumed fault point,  $U_f$ , equals:

$$U_f = U_s - Z_{X11} (I_s - I_{L11a}) \quad (11)$$

Where the load current during fault is estimated by:

$$I_{L11a} = \frac{d_x}{2 \cdot d_{DG}} \cdot U_s^* \left( P_{L1,0} (|U_s|/|U_{s,0}|)^{N_p} - jQ_{L1,0} (|U_s|/|U_{s,0}|)^{N_q} \right) \quad (12)$$

Since only the magnitude of the voltage in the DG-node is measured, the DG-voltage phasor is estimated using the following equation:

$$U_{DG,estimated} = \frac{|U_{DG}|^2 - Z_{X12}^* (S_{DG} - S_{L12,b} - S_{L2})}{U_f^*} \quad (13)$$

Eq. (13) contains  $|U_{DG}|$  on the right hand side, which is the absolute value of the measured DG voltage. The angle of estimated voltage phasor is used together with  $|U_{DG}|$ , to get an improved estimate.

The loads are estimated by:

$$S_{L12b} = \frac{d_{DG} - d_x}{2 \cdot d_{DG}} \cdot \left( P_{L1,0} (|U_{DG}|/|U_{DG,0}|)^{N_p} + jQ_{L1,0} (|U_{DG}|/|U_{DG,0}|)^{N_q} \right) \quad (14)$$

$$S_{L2} = P_{L2,0} (|U_{DG}|/|U_{DG,0}|)^{N_p} + jQ_{L2,0} (|U_{DG}|/|U_{DG,0}|)^{N_q}$$

The impedance from the substation to the fault location with this compensation method equals:

$$Z_{comp,3} = Z_{X11} + \frac{U_f}{I_f} = Z_{X11} + \frac{U_f}{I_S - I_{L11a} - I_{L12b} + I_{DG} - I_{L2}} \quad (15)$$

The load currents  $I_{L11b}$ ,  $I_{L12a}$  in Figure 7 is assumed to be very small, and is neglected. The results using this compensation are shown in Figure 9 and Figure 10.

## 7.2 Fault after the DG node

For a fault located after the DG connection point, the feeder can be represented as in Figure 8.

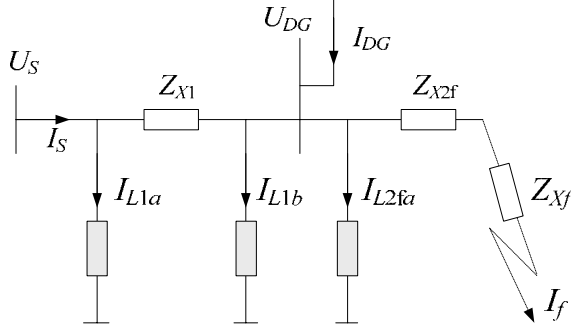

Figure 8: Equivalent circuit of feeder for fault located after the DG-node

The DG-voltage phasor is estimated using the following equation:

$$U_{DG,estimated} = U_S - Z_{X1} (I_S - I_{L1a}) \quad (16)$$

The angle of this voltage phasor is used together with the measured amplitude of the DG-voltage, to get an improved estimate.

The load currents are estimated from:

$$I_{L1a} = \frac{1}{2 \cdot U_S^*} \cdot \left( P_{L1,0} (|U_S|/|U_{S,0}|)^{N_p} - jQ_{L1,0} (|U_S|/|U_{S,0}|)^{N_q} \right)$$

$$I_{L1b} = \frac{1}{2 \cdot U_{DG,estimated}^*} \cdot \left( P_{L1,0} (|U_{DG}|/|U_{DG,0}|)^{N_p} - jQ_{L1,0} (|U_{DG}|/|U_{DG,0}|)^{N_q} \right) \quad (17)$$

$$I_{L2f} = \frac{(d_x - d_{DG})}{2 \cdot (d_E - d_{DG}) \cdot U_{DG,estimated}^*} \cdot \left( P_{L2,0} (|U_{DG}|/|U_{DG,0}|)^{N_p} - jQ_{L2,0} (|U_{DG}|/|U_{DG,0}|)^{N_q} \right)$$

The impedance from the substation to the fault location with this compensation method equals:

$$Z_{comp,3} = Z_{X1} + \frac{U_{DG,estimated}}{I_f} = Z_{X1} + \frac{U_S - Z_{X1} (I_S - I_{L1a})}{I_S - I_{L1a} - I_{L1b} + I_{DG} - I_{L2f}} \quad (18)$$

The results using this compensation are shown in Figure 9 and Figure 10.

## 7.3 Results with compensation utilizing DG-measurements during fault

Figure 9 and Figure 10 show the improvement of the fault distance estimate obtained using a pi-equivalent representation of the feeder, and measurements in the DG-node (comp. 3).



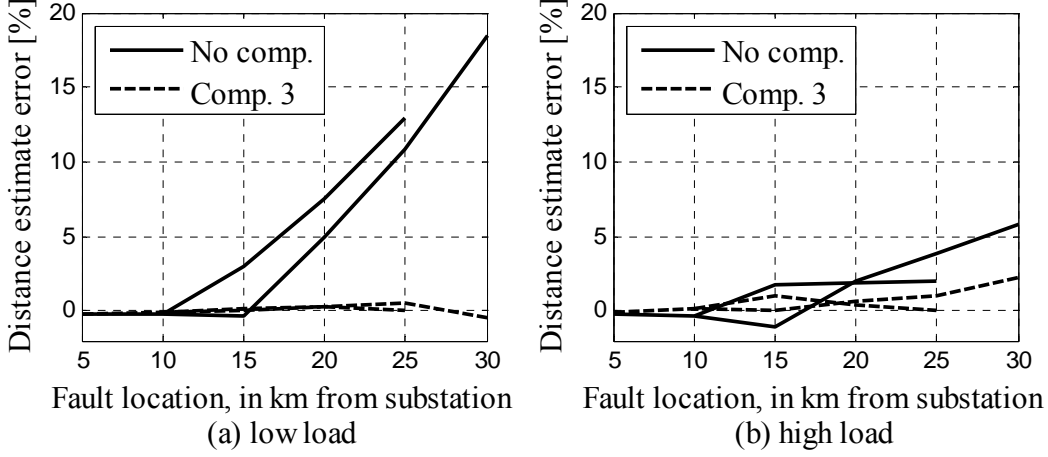

Figure 9: Distance estimate error for various fault locations, with the DG connected 15 km from the substation. (a) Low load case. (b) High load case.

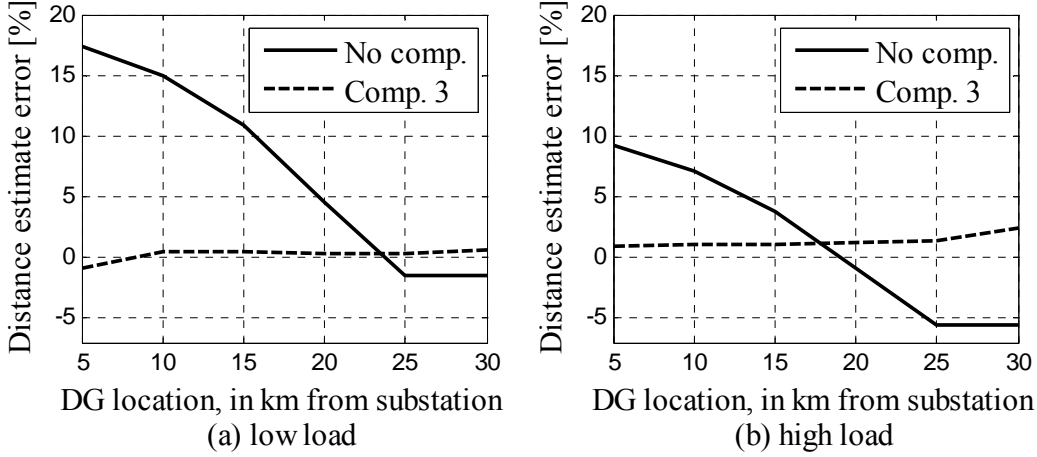

Figure 10: Distance estimate error for a fault 25 km from the substation on the main branch, for various DG locations. (a) Low load case. (b) High load case.

The result is good both for faults on the main and on the lateral branch, and for low load and high load cases. Since the angle of the DG voltage relative to the substation quantities is calculated and not measured, the accuracy depends on how good the representation of the line and loads is in the analytical model. The pi-equivalent represents a simplification, so there will be some error in the estimated DG voltage- and current-phasors. For a feeder with more unevenly distributed loads the errors could be larger than for the simulated case.

## 8 DECIDING THE FAULTED BRANCH USING DG-NODE MEASUREMENTS

If a calculated fault distance corresponds to more than one possible fault location, measurements in the DG-node can help in deciding the most probable location. For each candidate location the corresponding  $|U_{DG}|$  or  $|I_{DG}|$  is calculated, and compared to the measured values.

$$|\Delta U_{DG}| = \left| |U_{DG}| - |U_{DG,estimated}| \right|, \quad |\Delta I_{DG}| = \left| |I_{DG}| - |I_{DG,estimated}| \right| \quad (19)$$

The location where the calculated values are closest to the simulated values (smallest  $\Delta U_{DG}$  and  $\Delta I_{DG}$ ) is assumed to be the most probable.

$U_{DG,estimated}$  is found using eq. (13) if the fault is assumed to be located before the DG-node, and eq. (16) if it assumed to be located after the DG-node.

The DG current is estimated from:

$$I_{DG,estimated} = (S_{DG}/U_{DG,estimated})^* \quad (20)$$

For the studied feeder, the correct fault location in all cases corresponded to the smallest error between calculated and measured amplitude of DG-voltage and -current. With more laterals it might be more difficult to distinguish between possible locations. The method will not be useful when the fault is on a lateral branch after the DG-node.

## 9 CONCLUSION

With a short circuit on a distribution feeder, the distance to the fault location can be estimated from the substation current and voltage. Load and DG-units connected to the feeder induce errors in the estimate. The error is largest during low load. In a real network, inaccuracies in measurements and line data contribute with additional errors.

Compensation of errors due to load and DG, utilizing pre-fault substation measurements only (comp. 1), give varying results. In the low load case, the distance estimate error is reduced, while it is increased in the high load case.

When pre-fault power-flow from the DG is utilized in the compensation (comp. 2), the distance estimate error is reduced in both the low load and high load case. The improvement of the estimate, however, is dependent on the load level and the DG location. With a better representation of the DG, the accuracy of this method can most likely be improved.

A more accurate distance estimate is obtained when measurements from the DG-unit during fault are also utilized. The DG-measurements do not need to be synchronized with the substation measurements. A model where loads are included as impedances in a pi-equivalent is presented. With this method (comp. 3), the result is to a lesser degree dependent on load and DG conditions. A more uneven distribution of loads could however result in larger errors than obtained for the example feeder.

Measurements from the DG-node during fault can be used for deciding the most probable fault location, when more than one candidate location is found. For the studied feeder, the correct fault location could be decided in all cases. With more laterals it might be more difficult to distinguish between possible locations.

## REFERENCES

- [1]T. Takagi, Y. Yamakoshi, M. Yamaura, R. Kondow, T. Matsushima, "Development of a new type fault locator using the one-terminal voltage and current data", IEEE Transactions on Power Apparatus and Systems, No. 8, pp 2892-2898, August 1982.
- [2]R. Das, "Determining the Location of Faults in Distribution Systems", PhD-thesis, University of Saskatchewan, Canada, 1998, 206 pages
- [3]M. Lehtonen, M. Nordman, J. Pitkänen, T. Antikainen, S. Hänninen, O. Vähämäki, S. Sauha-aho, "New techniques for fault location in distribution networks". NORDAC 2006 Proceedings, Aug. 2006, 8 pages
- [4]M. Lehtonen, A. Matsinen, E. Antila, J. Kuru, "An Advanced Model for Automatic Fault Management in Distribution Networks", IEEE Power Engineering Society Winter Meeting, Vol. 3, 23-27 Jan. 2000, pp 1900-1904

- [5]D. Penkov, B. Raison, C. Andrieu, J.-P. Rognon, B. Enacheanu, “DG impact on three phase fault location. DG use for fault location purposes?”, International Conference on Future Power Systems, Nov. 2005, 6 pages.
- [6]J. Zhu, D. L. Lubkeman, A. A. Girgis, “Automated Fault Location and Diagnosis on Electric Power Distribution Feeders”, IEEE Transactions on Power Delivery, Vol. 12, No. 2, April 1997, pp 801-809.
- [7]H. Y. Li, P.A. Crossley, N. Jenkins, “Transient Directional Protection for Distribution Feeders with Embedded Generations”, 14<sup>th</sup> Power Systems Computation Conference, June 2002, 6 pages.
- [8]S.M. Brahma, A.A. Girgis, “Development of adaptive protection scheme for distribution systems with high penetration of distributed generation”, IEEE Transactions on Power Delivery, Vol. 19, Jan. 2004, pp 56-63
- [9]N. Perera, A.D. Rajapakse, A.M. Gole, “Wavelet-based relay agent for isolating faulty sections in distribution grids with distributed generators”, The 8<sup>th</sup> IEE International Conference on AC and DC Power Transmission, March 2006, pp 162-166
- [10]P. Kundur, “Power System Stability and Control” McGraw-Hill, 1994, New York, US, pp 271-278