

Berit Time og Sivert Uvsløkk

Intercomparison on measurement of water vapour permeance



Nordtest – project agreement 1529-01

BYGGFORSK

Norges byggforskningssinstitutt

Berit Time og Sivert Uvsløkk

Intercomparison on measurement of water vapour permeance

Nordtest – project agreement 1529-01

Prosjektrapport 339 – 2003

Prosjektrapport 339
Berit Time og Sivert Uvsløkk
**Intercomparison on measurement of water vapour
permeance**
Nordtest – project agreement 1529-01

Emneord: Tre, undertak, dampspærre, innvendig kledning,
fukt

ISSN 0801-6461
ISBN 82-536-0781-4

100 eks. trykt av
S.E. Thoresen as
Innmat: 100 g
Kymultra
Omslag: 200 g
Cyclus

© Copyright Norges byggforskningsinstitutt 2003

Materialet i denne publikasjonen er omfattet av åndverkslovens bestemmelser. Uten særskilt avtale med Norges byggforskningsinstitutt er enhver eksemplarframstilling og tilgjengeliggjøring bare tillatt i den utstrekning det er hjemlet i lov eller tillatt gjennom avtale med Kopinor, interesseorgan for rettighetshavere til åndsverk.

Utnyttelse i strid med lov eller avtale kan medføre erstatningsansvar og inndragning, og kan straffes med bøter eller fengsel.

Adr.: Forskningsveien 3 B
Postboks 123 Blindern
0314 OSLO
Tlf.: 22 96 55 55
Faks: 22 69 94 38 og 22 96 55 08

Content

Content 3

Abstract 4

1. Introduction 5

2. Method and Nomenclature 6

3. Test material and conditions 7

3.1 Test material 7

3.2 Test conditions 7

4. Results 11

4.1 In general 11

4.2 Calculations by the NBI 11

4.3 Underlay for roofing 12

4.4 Hard wood fibre boards 14

4.5 Dampproof course 16

5. Discussion 17

5.1 In general 17

5.2 Underlay for roofing 17

5.3 Hard wood fibre board 17

5.4 Dampproof course 18

7. Conclusions 19

6 References 20

Appendix 1 21

Appendix 2 23

Appendix 3 28

Appendix 4 29

Abstract

A Round Robin test has been arranged in order to compare test facilities and results for measuring water vapour permeance/water vapour resistance of 3 different types of building products.

The tests have been performed according to EN ISO 12572:2001 *Hygrothermal performance of building materials and products – Determination of water vapour transmission properties*.

The reported results and the reported raw data show that for the two relatively vapour open products in this test, the hard wood fibre board and the underlay for roofing, the water vapour resistance and the s_d -value can be decided with a certainty of approximately $\pm 10\%$. This is supposed the air layer resistance between the salt solution and the test sample is corrected for, the air velocity above the test sample is between approximately 1,5 m/s and 2,0 m/s (see appendix 4) and the masked edge effect is corrected for (important for thicker specimens).

The reported results show that there is a lack of stabilized weight loss for the damp proof course and the criteria for calculation of an s_d -value of the standard is not fulfilled. Earlier experience on measurements on very vapour tight materials is confirmed through this project. It might be difficult to get a stabilized weight loss for very vapour tight products.

Compared to the results from [Galbraith 1993] there has been an improvement in accuracy of results. In [Galbraith 1993] measurements on a type of particleboard and extruded polystyrene showed that the results could be decided within a $\pm 21\%$ and a $\pm 19\%$ banding. The results for the underlay for roofing and the hard wood fibre board respectively was within a $\pm 10\%$ and a $\pm 8\%$ banding when correcting for air resistances on both sides of the samples and the masked edge effect.

1. Introduction

A Round Robin test has been arranged in order to compare test facilities and results for measuring of water vapour permeance/water vapour resistance of 3 different kind of building products.

The tests have been performed according to EN ISO 12572:2001 *Hygrothermal performance of building materials and products – Determination of water vapour transmission properties*.

The following laboratories have participated in the project:

<i>Abbreviation used in the report</i>	<i>Official name</i>	<i>Country</i>	<i>Contact persons</i>
SBI	Danish Building and Urban Research	Denmark	Asta Nicolajsen
TI	Danish Technological Institute	Denmark	Robert Knudsen/ Pia Rostgaard
DTU	Technical University of Denmark	Denmark	Kurt Kielsgaard Hansen
VTT	VTT Building Technology	Finland	Taru Haimala
Chalmers	Chalmers University of Technology	Sweden	Lars-Olof Nilsson/ Ingemar Segerholm
NBI	Norwegian Building Research Institute	Norway	Berit Time

The project was financially partly supported by Nord Test (project agreement 1529-01). NBI acted as a project leader.

Test material has been supplied by Norsk Wallboard as (hard wood fibre boards), Icopal as (underlay for roofing) and Icopal Plastic Membrane as (earlier Monarflex as) (dampproof course).

2. Method and Nomenclature

The tests have been performed according to EN ISO 12572:2001 *Hygrothermal performance of building materials and products – Determination of water vapour transmission properties*. For description of test method and test procedures, see [EN ISO 12572:2001].

The test condition Set C according to chapter 7.1 in the standard has been used for all three test series. Set C is a “wet” cup test. The relative humidity inside the cup is 93 %, the surrounding relative humidity is 50 % and temperature is set to be 23 °C.

The expression of the results can be presented as

- water vapour resistance (Z), or
- the water vapour permeability (δ), or
- the water vapour resistance factor (μ) or
- the s_d -value (water vapour diffusion-equivalent air layer thickness¹).

More detailed explanation of the expressions/terms is given in EN ISO 12572:2001.

In this report the results are presented as s_d -values.

¹ the thickness of a motionless air layer which has the same water vapour resistance as the specimen

3. Test material and conditions

3.1 Test material

The tested products are

- Water vapour open underlay for roofing, approximately 1 mm thick (a foil of polyurethane (PU) laminated with foils made of polypropylene (PP) on both sides). The weight of the underlay for roofing is 300 g/m^2
- 11 mm hard wood fibre board for indoor cladding for walls and ceilings. The density of the hard wood board samples was $878 \pm 12 \text{ kg/m}^3$. The standard deviation was 1,4 % of the average value. These measurements were performed at NBI (50 % RH and 23°C) before shipping out.
- polyethylene dampproof course, approximately 0,25 mm thick (reinforcement-mash of polypropylene excluded). The weight of the product is 275 g/m^2 reinforcement-mash included. The density of the LDP is $0,92 \text{ g/m}^3$. The reinforcement-mash is made of polypropylene.

Test specimens were cut according to the schema showed in appendix 1 in order to randomise the test samples as much as possible.

3.2 Test conditions

Table 1 to Table 9 show an overview of the following parameters given/measured by the participating laboratories;

- diameter of specimens
- diameter of exposed area
- masked edge (in mm)
- masked edge (in % of the exposed area)
- average barometric pressure ($\pm \text{stdv}$) during the test-period
- average temperature ($\pm \text{stdv}$) during the test-period in the surrounding air
- average relativ humidity ($\pm \text{stdv}$) during the test-period in the surrounding air
- thickness of air-layer between test sample and salt solution at start
- average air velocity above test specimens during test-period

Photo or drawings of the test cups of the participants is given in appendix 2.

Table 1 Diameter of specimens, measured by the participants

A	Diameter of specimens (mm)					
	SBI	TI	DTU	VTT	Chalmers	NBI
Underlay for roofing	100	171	100	130	97	174
Hard wood fibre board	100	171	79	130	89	174
Dampproof course	-	171	100	130	97	174

Table 2 Diameter of exposed area, measured by the participants

B	Diameter of exposed area (mm)					
	SBI	TI	DTU	VTT	Chalmers	NBI
Underlay for roofing	80	157	90	110	89*	174
Hard wood fibre board	80	157	79	110	89*	174
Dampproof course	-	157	90	110	89*	174

*exposed area to salt solution. To “air” the whole area is exposed.

Table 3 Masked edge, measured by the participants (mm)

C=B-A	Masked edge, measured by the participants (mm)					
	SBI	TI	DTU	VTT	Chalmers	NBI
Underlay for roofing	20	14	10	20	8	11
Hard wood fibre board	20	14	0	20	0	11
Dampproof course	-	14	10	20	8	11

Table 4 Masked edge, in % of the exposed area

	Masked edge, in % of the exposed area					
	SBI	TI	DTU	VTT	Chalmers	NBI
Underlay for roofing	25,0	8,9	11,1	18,2	9,0	6,7
Hard wood fibre board	25,0	8,9	0	18,2	0	6,7
Dampproof course	-	8,9	11,1	18,2	9,0	6,7

Table 5 Thickness of air-layer inside the cup at start (mm)

	Thickness of air-layer inside the cup at start (mm)					
	SBI	TI	DTU	VTT	Chalmers	NBI
Underlay for roofing	15	10	15	18	36	15
Hard wood fibre board	15	10	15	18	33	15
Dampproof course	-	10	15	18	42	15

Table 6 Average air velocity above test specimens during testing

	Average air velocity above test specimens during testing (m/s)					
	SBI	TI	DTU	VTT	Chalmers	NBI
Underlay for roofing	2,0	*	2,1	0,15	0,13	3,6
Hard wood fibre board	2,0	*	2,1	0,15	0,13	0,3
Dampproof course	-	*	2,1	0,15	0,13	0,3

*not measured, assumed close to zero

Table 7 Average barometric pressure \pm stdv during the test-period

	Average barometric pressure/ \pm stdv during the test-period (hPa)					
	SBI	TI	DTU	VTT	Chalmers	NBI
Underlay for roofing	998,2 \pm 11,2	1013,3 \pm 0	965,0 \pm 5,7	1008,7 \pm 9,5*	1014,1 \pm 5,8**	1008,6 \pm 3,4
Hard wood fibre board	1015,2 \pm 9,1	1013,3 \pm 0	981,8 \pm 8,4	1008,7 \pm 9,5*	1014,1 \pm 5,8**	1000,4 \pm 3,1
Dampproof course	-	1013,3 \pm 0	969,2 \pm 6,8	1008,7 \pm 9,5*	1014,1 \pm 5,8**	1008,2 \pm 9,4

*barometric pressure only registered when weighing, average of these reported

**the barometric pressure only registered the last part of the measuring period

Table 8 Average temperature \pm stdv during the test-period

	Average temperature \pm stdv during the test-period ($^{\circ}$ C)*					
	SBI	TI	DTU	VTT	Chalmers	NBI
Underlay for roofing	23,3 \pm 0,2	23 \pm 0	22,7 \pm 0,3	22,5 \pm 0,5	20,0 \pm 0,1	23,5 \pm 0,2
Hard wood fibre board	23,0 \pm 0,1	23 \pm 0	23,1 \pm 0,2	22,5 \pm 0,5	20,0 \pm 0,1	22,6 \pm 0,1
Dampproof course	-	23 \pm 0	22,9 \pm 0,3	22,5 \pm 0,5	20,0 \pm 0,1	24,0 \pm 0,2

* It is not perfectly clear how the temperatures have been registered for all participants

Table 9 Average relative humidity \pm stdv during the test-period

	Average relative humidity \pm stdv during the test-period (%)*					
	SBI	TI	DTU	VTT	Chalmers	NBI
Underlay for roofing	48,3 \pm 0,3	50,6 \pm 1,8	51,2 \pm 0,8	50 \pm 0	50,6 \pm 0,5	51,5 \pm 0,1
Hard wood fibre board	48,7 \pm 0,3	50,9 \pm 2,3	49,9 \pm 0,8	50 \pm 0	50,6 \pm 0,5	51,3 \pm 0,1
Dampproof course	-	50,6 \pm 1,8	50,3 \pm 1,2	50 \pm 0	50,6 \pm 0,5	50,2 \pm 0,3

* It is not perfectly clear how the relative humidities have been registered for all participants

4. Results

4.1 In general

The results of the different test samples have been reported by the participants as Z_p - values (water vapour resistances) and as raw measuring data in an “NBI spread sheet”, see appendix 3 for an example.

The results reported as water vapour resistances (Z_p) have been converted by the NBI to s_d -values and presented in Table 10. It is assumed 20°C, the water vapour permeability of air is set like 1,936E-10 kg/msPa and the barometric pressure of the air is set like 1013,25 hPa for all results. The results reported from the participants for the underlay for roofing, the hard wood fibre board, and the dampproof course is presented in Table 10. A closer comparison and presentation of the results of all samples are shown in Figure 1 to Figure 6.

Table 10 The results reported from the participants for the underlay for roofing, the hard wood fibre board, and the dampproof course.

Test material	s_d-value (mm), average of 5 values / deviation from mean value (%)							Standard-deviation (mm)
	Laboratory						Average (mm)	
	SBI	TI	DTU	VTT	Chalmers	NBI		
Hard wood fibre board	348	389	416	339	410	360	377	33
	-8	3	10	-10	9	-5		
Underlay for roofing	155	263	188	221	232	159	203	43
	-24	30	-7	9	14	-22		

Test material	s_d-value (m), average of 5 values / deviation from mean value (%)						Standard-deviation (m)	
	Laboratory							Average (m)
	SBI	TI	DTU	VTT	Chalmers	NBI		
Dampproof course		150	101	28	122	95	99	45
		51	2	-72	23	-4		

4.2 Calculations by the NBI

In Figure 2 and Figure 5 is presented the average values reported by each laboratory compared with the average values for the different test samples calculated by the NBI (from the reported raw data).

In calculations NBI has done the following assumptions:

- Any corrections for the (assumed) weight change because of any change in barometric pressure when weighing (uplift) has not been accounted for. (That is the weight of the control-bar has been set like 1000 grams).
- Where data on barometric pressure is missing an average of the reported data is used. E.g if only data on the barometric pressure when weighing the test samples exist an average of these data for the whole measuring period have been used. If any other climatic data is missing the same procedure has been followed.
- Only raw measuring data that show a stabilized weight loss is used. That means e.g. no calculations have been performed for the dampproof course.

- For TI no air velocity has been measured. As the cups have been stored in a room with very little air movement an air velocity of 0,1 m/s has been used.
- For all measuring series is considered the temperature inside and outside the cup is equal.
- A few weighings with inconsistent data have been removed.

The NBI spread sheet (calculation tool) account for the air layer thickness between the salt solution and the test sample and the masked edge effect according to the standard Annex G and Annex F. The air layer resistance above the test sample is accounted for by the aid of the equation shown in appendix 4. The standard does not account for this.

The weighing is carried on until a stabilized weight loss is achieved. That means we continue weighing until five successive determinations of change in mass per weighing interval are constant within $\pm 5\%$ of the mean value for each test specimen.

4.3 Underlay for roofing

The results for the underlay for roofing from the reported data and from the calculations made by the NBI of the raw measured data are presented in Figure 1 and Figure 2.

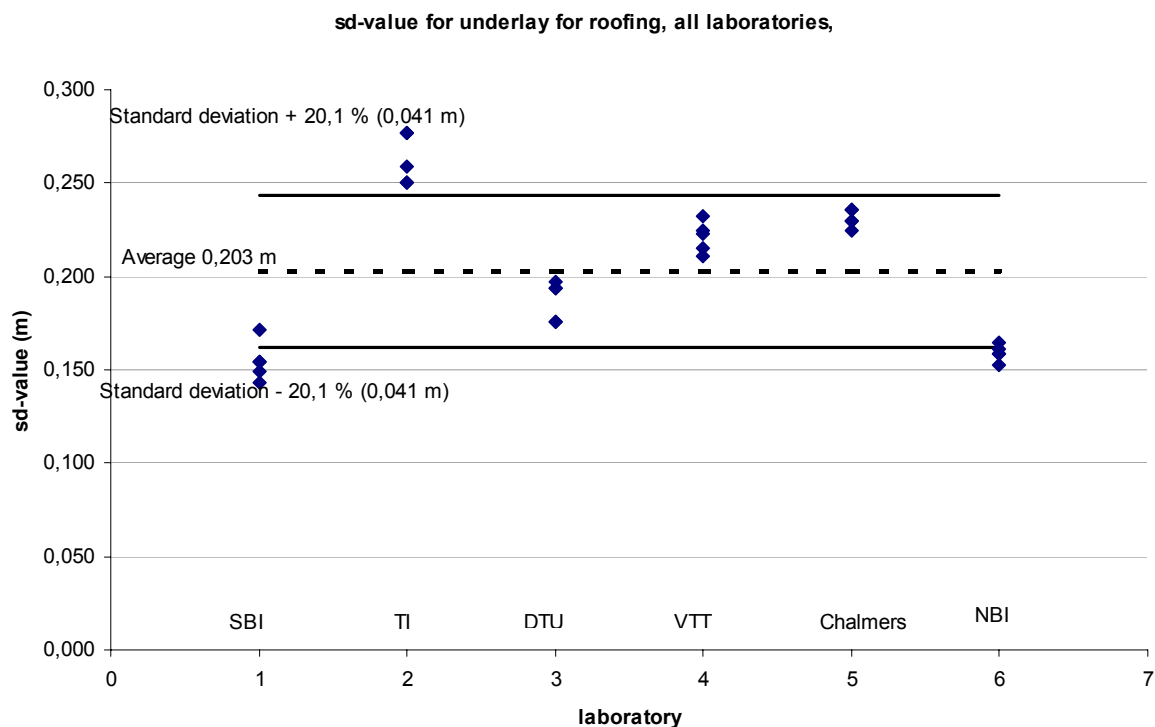

Figure 1
Results from measurements of underlay for roofing reported by the different participating laboratories. Reported Z_p values converted to s_d -values by the NBI. The standard deviation is calculated from all reported data.

sd-values for underlay for roofing, all laboratories,

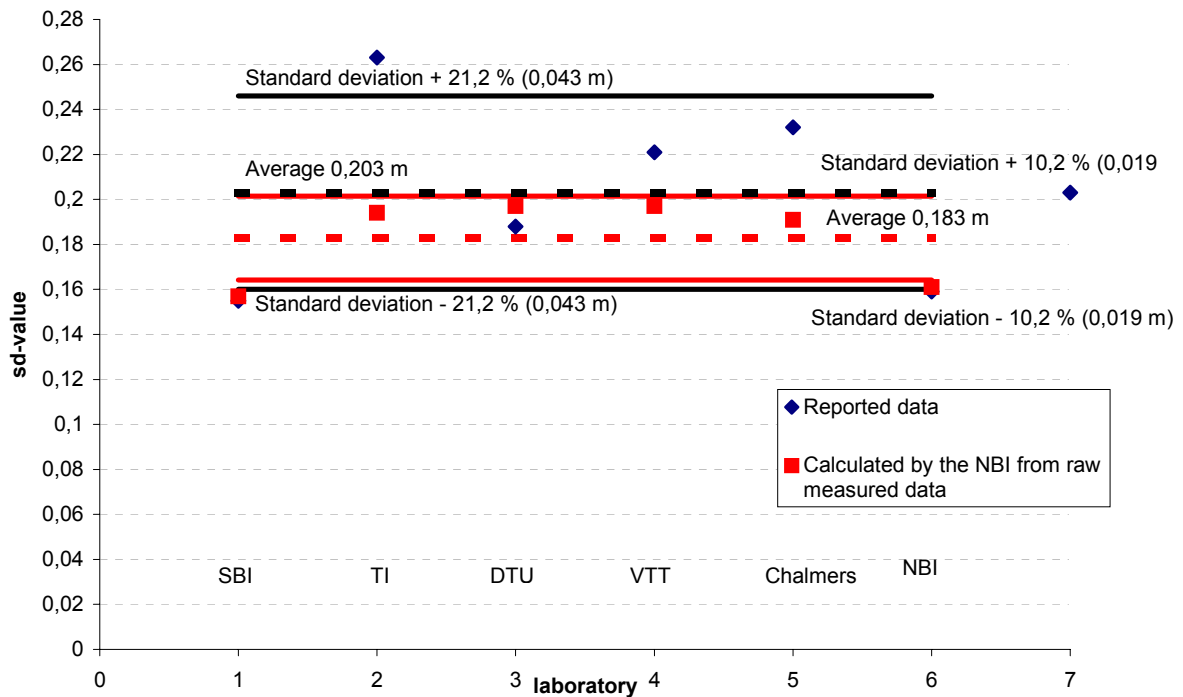

Figure 2
Results from measurements of underlay for roofing reported by the different participating laboratories. Reported Z_p values converted to s_d -values by the NBI. These results (in black) are compared with results calculated by the NBI from raw material data (in red). The standard deviation is calculated from the average values of the participants results.

In Figure 3 is presented the s_d -value for the underlay for roofing reported by the participating laboratories.

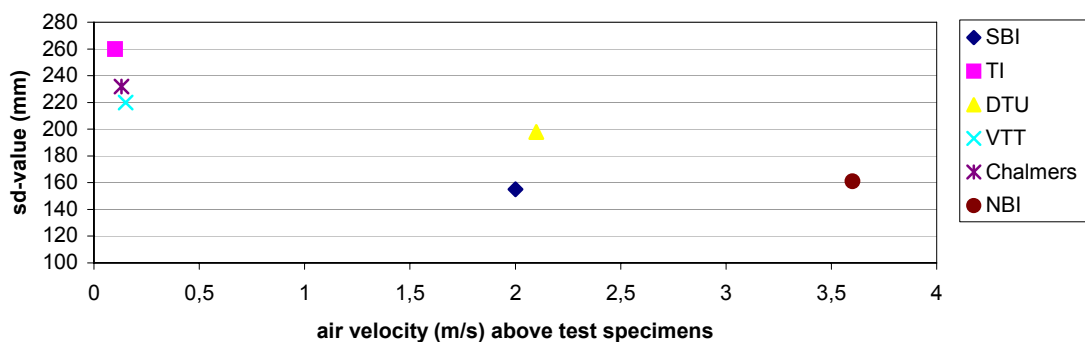

Figure 3
The results for the underlay for roofing calculated by the participating laboratories (converted to s_d -values by the NBI) presented as a function of the air velocity above test specimens in the test performance.

4.4 Hard wood fibre boards

The results for the hard wood fibre boards, from the reported data and from the calculations made by the NBI of the raw measured data, are presented in Figure 4 and Figure 5.

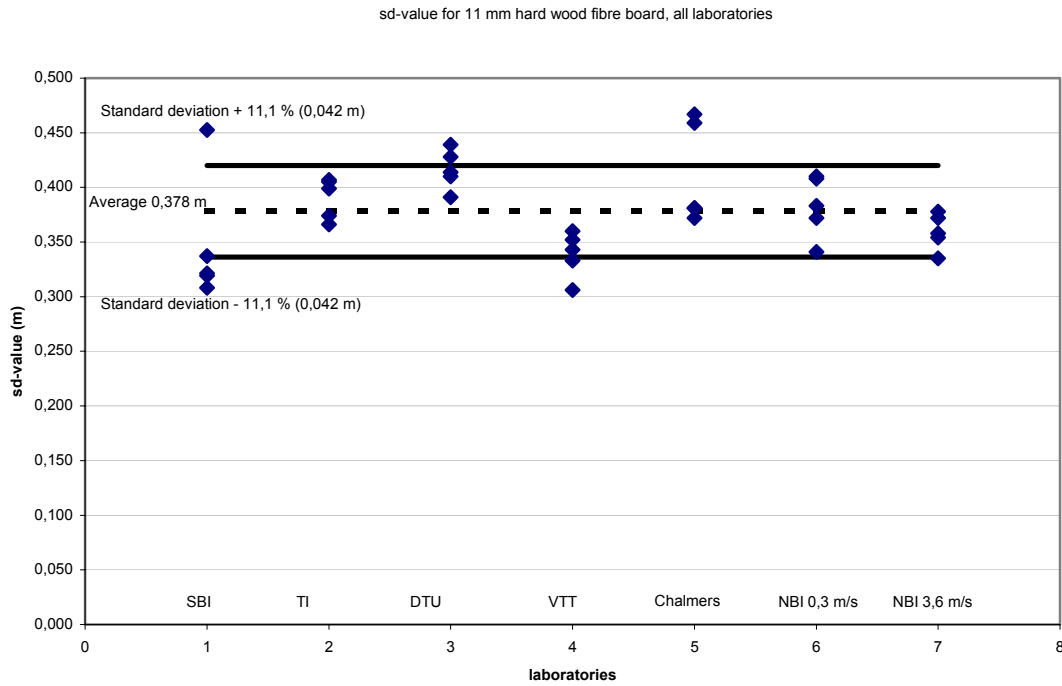

Figure 4
 Results from measurements of hard wood fibre boards reported by the different participating laboratories. Reported Z_p values converted to s_d -values by the NBI. The standard deviation is calculated from all reported data.

sd-values for 11 mm hard wood fibre board, all laboratories, average values

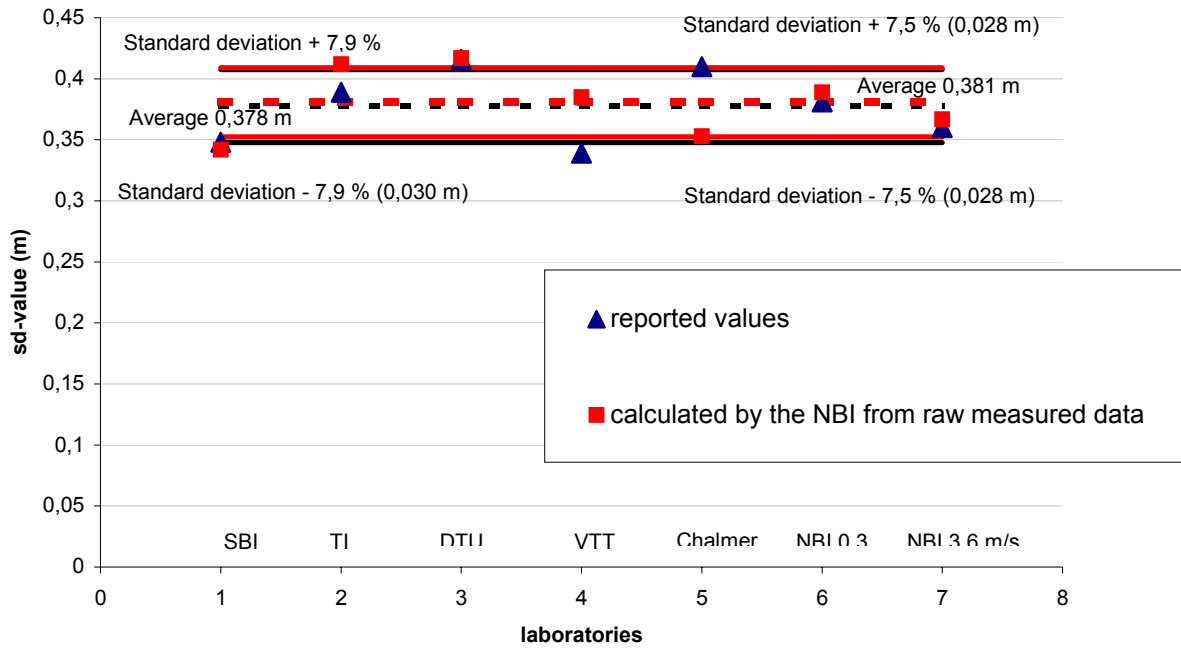

Figure 5
 Results from measurements of hard wood fibre boards reported by the different participating laboratories. Reported Z_p values converted to s_d -values by the NBI. The results (in black) are compared with results calculated by the NBI from raw material data (in red). The standard deviation is calculated from the average values of the participants results.

4.5 Dampproof course

The results from the measurements on the damp proof course reported by the participant is presented in Figure 6.

None of the reported results fulfil the criteria for ending the test procedure... "continue weighings until five successive determinations of change in mass per weighing interval for each test specimens are constant within $\pm 5\%$ of the mean value for this specimen". As this criteria is not fulfilled results according to the NBI-procedure have not been calculated.

The results are totally dependent on which weights are used while calculating the Z_p or s_d -values.

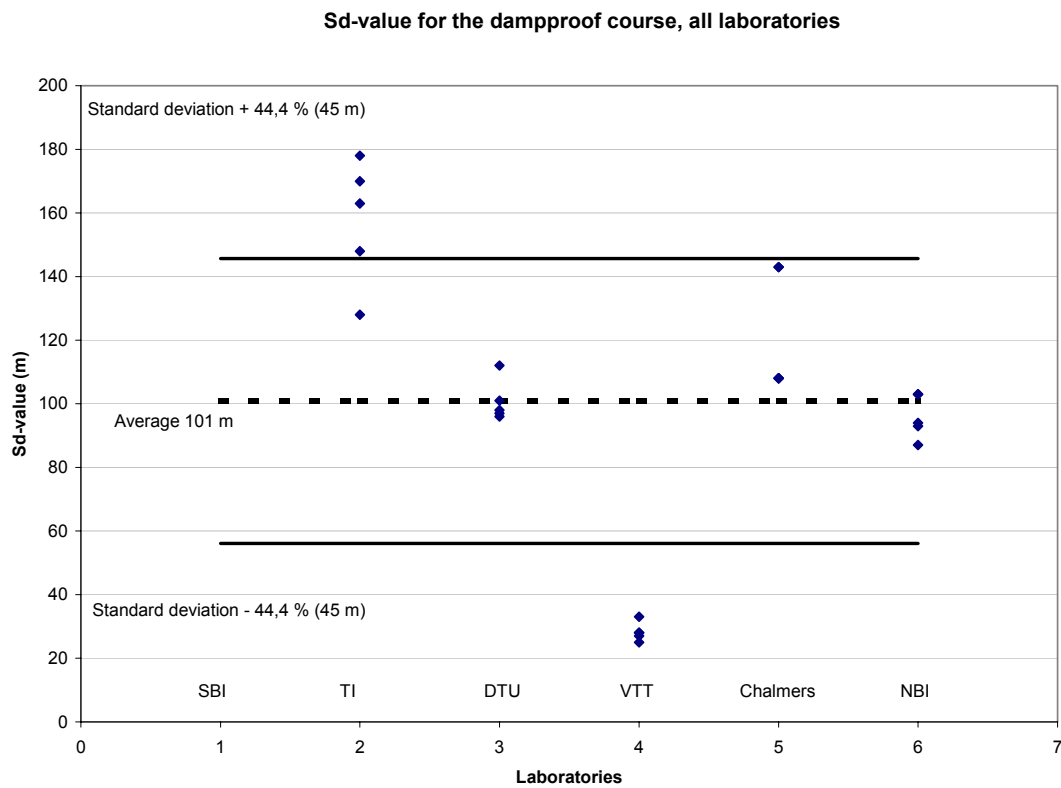

Figure 6
Results from measurements of the dampproof course reported by the different participating laboratories. Reported Z_p values converted to s_d -values by the NBI.

5. Discussion

5.1 In general

Measurements of water vapour transmission has been performed by 6 different laboratories on test samples prepared by one of the laboratories (NBI). The tested materials were hard wood fibre boards, underlay for roofing and a dampproof course.

5.2 Underlay for roofing

The average result of all reported calculated data, converted to s_d -value by the NBI, is 203 mm with a standard deviation of ± 41 mm (i.e 20,1 %). The average result of all reported data calculated by the NBI from reported raw data material is 183 mm with a standard deviation of ± 19 mm (i.e 10,2 %).

According to a budget of uncertainties, developed by the NBI for commercial measurements of water vapour permeance [NBI 2001], we normally perform measurements with an uncertainty for each cup from 7 % to 14 %. The main contribution to the uncertainty budget is the uncertainty of the measurement of the relative humidity in the surrounding climate and the uncertainty of the relative humidity of the salt solution in the cup.

The results, when NBI has calculated the water vapour resistances from the reported raw measured data, have a smaller standard deviation than what was achieved from the calculated reported data. NBI has corrected the measured data for

- the air resistance above the cup (by the aid of the equation in appendix 4)
- the air resistance between the salt solution and the test sample (Annex G, EN ISO 12572: 2001)
- the masked edge effect (Annex F, EN ISO 12572: 2001)

The standard minimize the resistance of the air layer above the cup by requiring an air velocity of at least 2 m/s for permeable materials and thin membranes (Annex G, EN ISO 12572: 2001).

In Figure 3 is presented the s_d -values reported by the participants as a function of air velocity above the test samples during testing. There is a tendency of a decreasing s_d -value and the air velocity above the test samples. The resistance of an air layer dependent on air velocity is shown in appendix 4.

5.3 Hard wood fibre board

The average result of all reported calculated data, converted to s_d -value by the NBI, is 378 mm with a standard deviation of ± 30 mm (i.e 7,9 %). The average result of all reported data calculated by the NBI from reported raw data material is 381 mm with a standard deviation of ± 28 mm (i.e 7,5 %).

We can see there are less difference between reported results and calculated (by the NBI) for the hard wood fibre board.

An uncertainty-level of approximately ± 10 % probably has to be accepted for these kind of measurements.

In Table 11 is shown which laboratories have corrected for the air resistances and the masked edge effects.

Table 11

A summary whether the different laboratories have corrected for the air layer resistances and the masked edge effect in their reported results (Z_p -values)

Results corrected for		SBI	TI	DTU	VTT	Chalmers	NBI
Resistance of air layers above test sample	Not according to standard	no	no	no	no	no	yes
Resistance of air layers between salt solution and test sample	Annex G (EN ISO 12572)	yes	no	yes	no	no	yes
The effect of the masked edge of the specimen	Annex F (EN ISO 12572)	yes	yes	yes	yes	no	yes

According to Figure 3 it can be seen that the three laboratories with the highest s_d -values (highest resistances) have not corrected for the air layer between the salt solution and the test sample.

5.4 Dampproof course

The test performance on the dampproof course appeared to be difficult to perform. This is also the experience from measurements on very vapour tight materials. The average result of all reported calculated data, converted to s_d -value by the NBI, is 101 m with a standard deviation of ± 45 m (i.e. 44,4 %).

In the reported material is seen that test procedure criteria for fulfilment of this test has not been achieved.

It has therefore been chosen not to investigate the results any further.

6. Conclusions

A Round Robin test has been arranged in order to compare test facilities and results for measuring of water vapour permeance/water vapour resistance of 3 different types of building products.

The tests have been performed according to EN ISO 12572:2001 *Hygrothermal performance of building materials and products – Determination of water vapour transmission properties*.

The reported results and the reported raw data show that for the two relatively vapour open products in this test, the hard wood fibre board and the underlay for roofing, the water vapour resistance and the s_d -value can be decided with a certainty of approximately $\pm 10\%$. This is supposed the air layer resistance between the salt solution and the test sample is corrected for, the air velocity above the test sample is between approximately 1,5 m/s and 2,0 m/s (see appendix 4) and the masked edge effect is corrected for (important for thicker specimens).

The reported results show that there is a lack of stabilized weight loss for the damp proof course and the criteria for calculation of an s_d -value of the standard is not fulfilled. Earlier experience on measurements on very vapour tight materials is confirmed through this project. It might be difficult to get a stabilized weight loss for very vapour tight products.

Compared to the results from [Galbraith 1993] there has been an improvement in accuracy of results. In [Galbraith 1993] measurements on a type of particleboard and extruded polystyrene showed that the results could be decided within a $\pm 21\%$ and a $\pm 19\%$ banding. The results for the underlay for roofing and the hard wood fibre board respectively was within a $\pm 10\%$ and a $\pm 8\%$ banding when correcting for air resistances on both sides of the samples and the masked edge effect.

7. References

Nilsen, T.N, Bergheim, E., Uvsløkk, S., *Permeance Measurement of Materials with Extremely Low Resistance to Water Vapour Diffusion*, Proceedings of the 4th Symposium in Building Physics in the Nordic Countries, Espoo, Finland, September 9-10, 1996.

EN ISO 12572:2001. *Hygrothermal performance of building materials and products – Determination of water vapour transmission properties*. CEN European Committee for Standardization.

NBI, 2001, *Local Handbook for Material Testing (In Norwegian)*. Internal quality procedures for testing of among other properties water vapour transmission property according to NS-EN ISO 12572.

Galbraith, G.H., *Intercomparison on measurement of water vapour permeability*, University of Strathclyde, Dept. of Mechanical Engineering, Glasgow, 1993, EUR 14349 EN, .

Appendix 1

How the samples have been randomised and picked out

The underlay for roofing and the dampproof course:

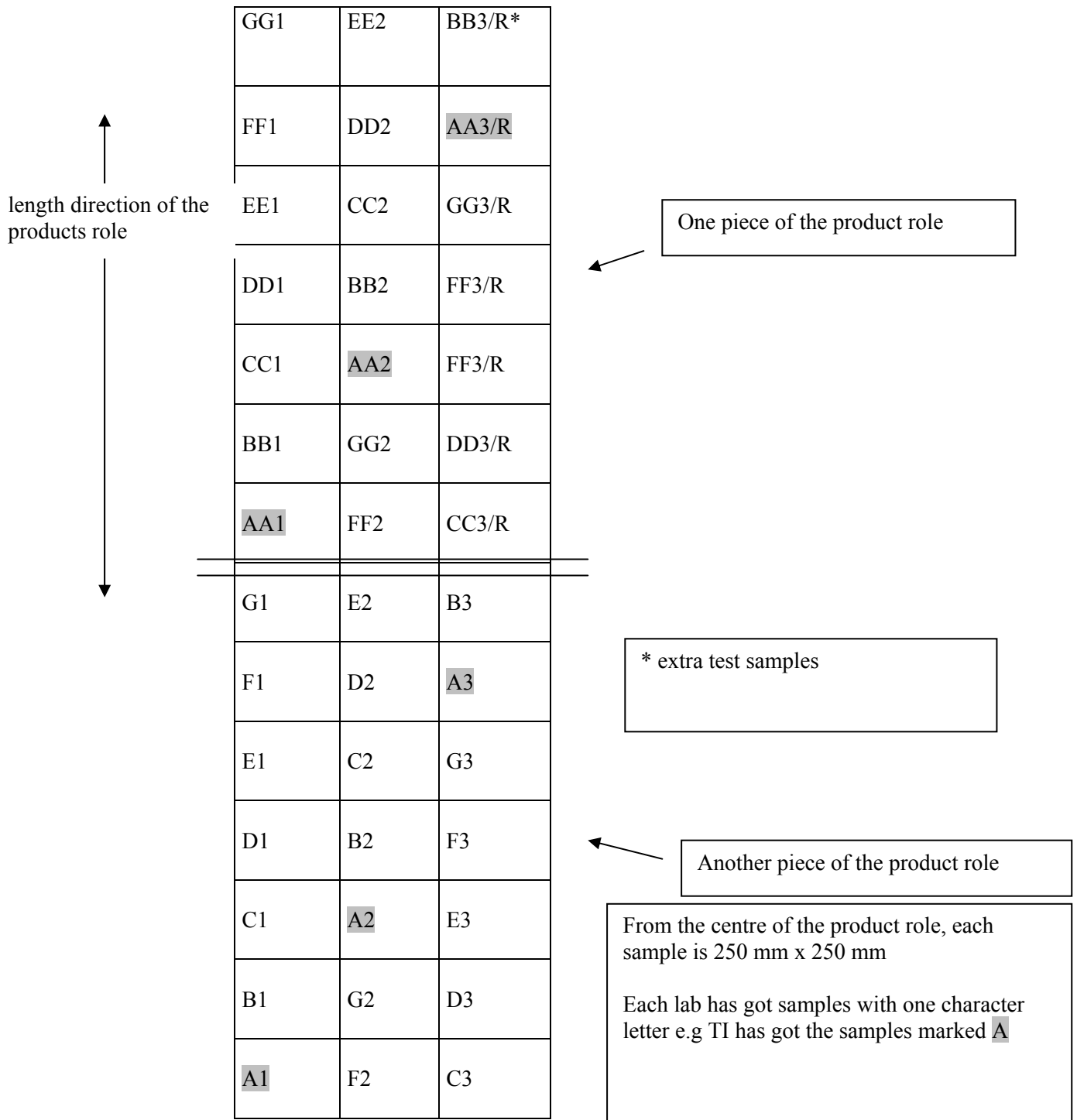

The hard wood fibre boards:

Samples are taken from three different boards. They have been taken from the centre of the board. Originally there were cut out 9 samples for each laboratory. The density was measured and the three most deviating pieces (regarding density) were removed. The last number in the code tells which

laboratory has got the samples (E.g. TI has got the samples marked 4 (at the en of the code) . Each sample is 250 mm x 250 mm.

C3-2	C3-3	C3-4	C3-5	C3-6	C3-7	C3-1
C2-2	C2-3	C2-4	C2-5	C2-6	C2-7	C2-1
C1-2	C1-3	C1-4	C1-5	C1-6	C1-7	C1-1

B3-5	B3-6	B3-7	B3-1	B3-2	B3-3	B3-4
B2-5	B2-6	B2-7	B2-1	B2-2	B2-3	B2-4
B1-5	B1-6	B1-7	B1-1	B1-2	B1-3	B1-4

A3-1	A3-2	A3-3	A3-4	A3-5	A3-6	A3-7
A2-1	A2-2	A2-3	A2-4	A2-5	A2-6	A2-7
A1-1	A1-2	A1-3	A1-4	A1-5	A1-6	A1-7

Appendix 2

Drawings/photos of cups used by the different laboratories

SBI



(Description in Danish)

Vores udstyr består af:

Kop, prøvestyr (krave med gevind der holder prøveemne fast), gummipakning og glideskiv.

Prøvelegemerne monteres i kopperne så rækkefølge nedefra og op efter er:
Kop, pakning, prøvelegeme, glideskive, prøvestyr.

Prøvestyrene tilspændes med et moment på 14 N.

TI

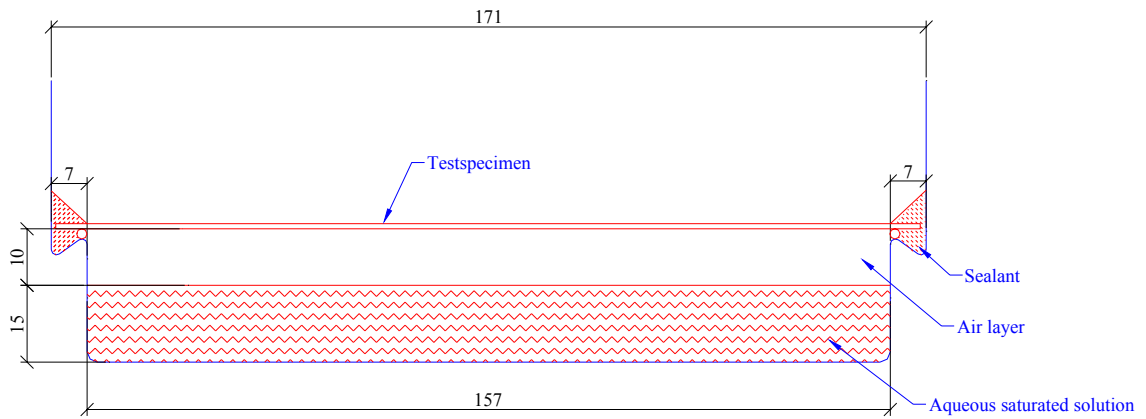

All dimensions are in mm

DTU

Cup for thicker specimens

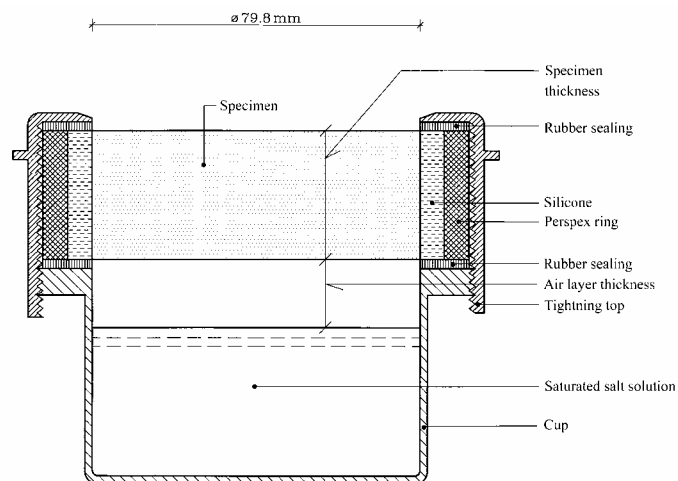

Cup for thinner specimens

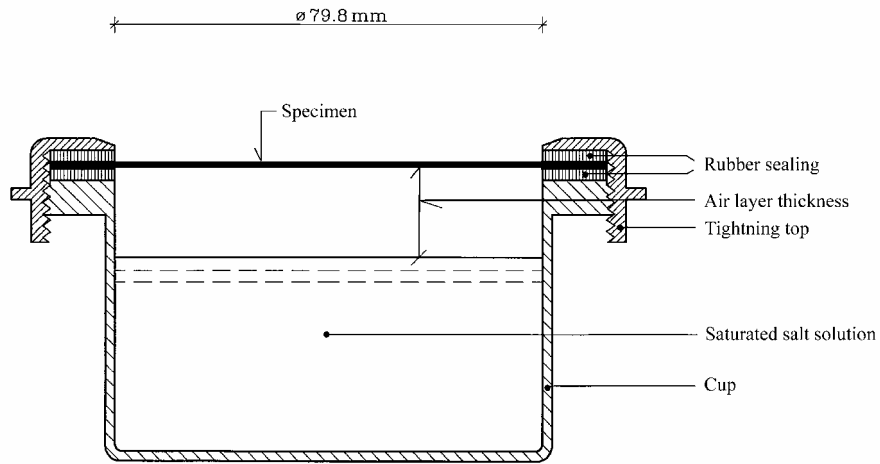

VTT

Have not received any photos/drawings. Can you please send me something (in a file) ?

Chalmers

Test cup design

Glass cups with an inner diameter of 91 mm were used and sealed with a double-sided tape with a thickness of 1 mm (Figure 1 and 2). Figure 3 shows a photography of each of the three cups.

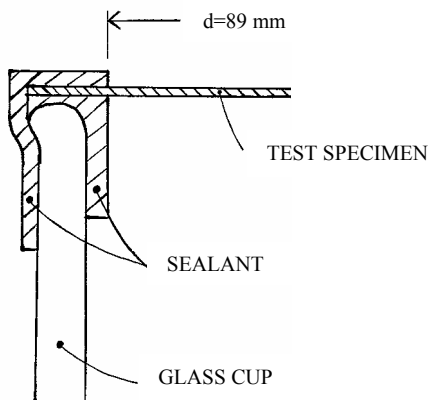

Figure 1 Cup design used for thin test samples (damp proof course and underlay for roofing)

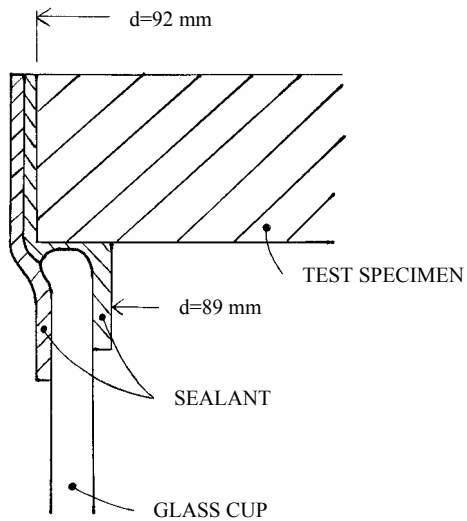

Figure 2 *Cup design used for thick test samples (wood fibre board)*

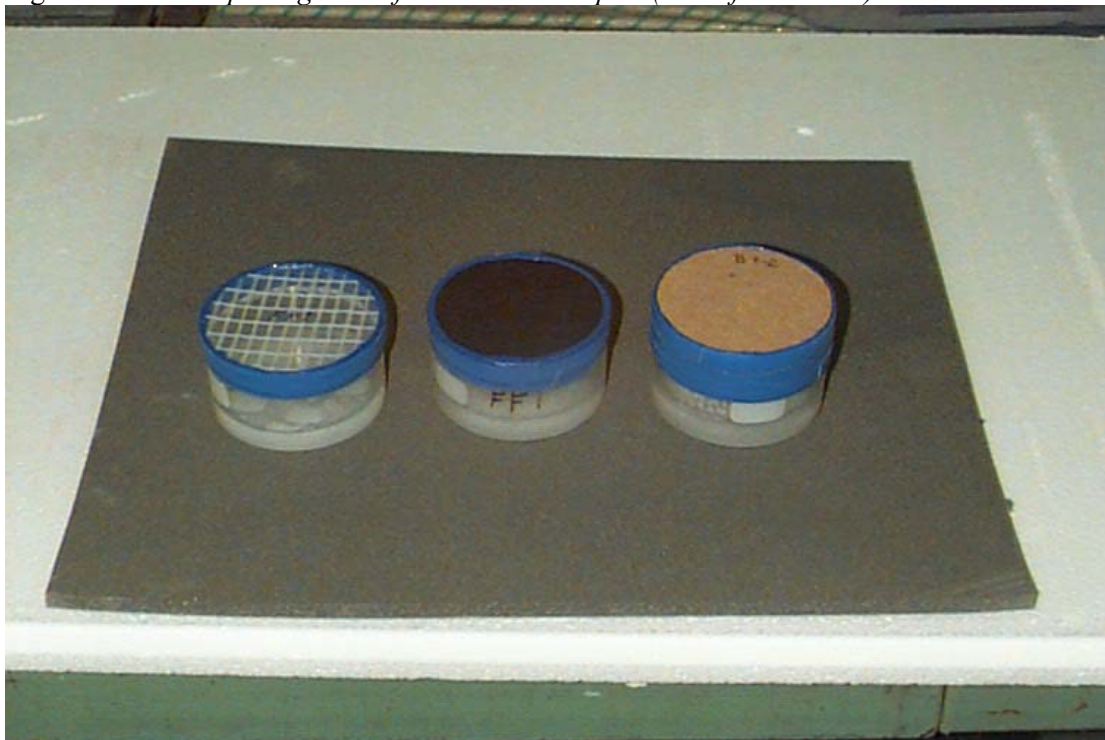
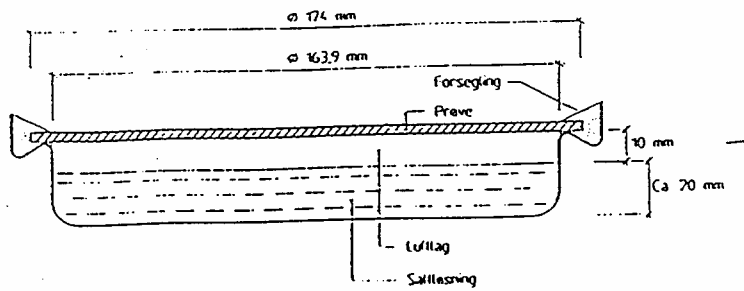

Figure 3 **One of each of the three types of cups**

Sealant details

As sealant, a double-sided tape was used. The tape is originally designed to waterproof joints in the System Platon. According to the manufacturer (Isola-Platon AB, www.isola.se), the product is water- and diffusion proof as well as highly resistant to common chemicals.

NBI



(Figure in Norwegian)

The cups are made of aluminium. The sealing compound consists of 70 % plasticine and 30 % bees wax. The distance between the salt solution is 15 mm (not 10 as in the figure)

Appendix 3

The NBI “spread sheet”- raw material data (in Norwegian)

Overlappingszone:				0,0055 m							
Salttype i boksene:				KNO3							
Sirkulært måleareal med diameter:			0,163	m							
Måleareal:				0,021 m ²							
Veiing nummer		1	2	3	4	5	6	7	8	9	10
(1)Produktnavn:	NN										
(2)Oppdragsgiver:	Nordtest										
(3)Prosjektnummer:	E 8764										
(4)Produkttype:	Woodfiber board										
(5)Tykkelse, mm:	x										
(6)Målenummer:	y										
(12)Dato (CTRL+SHIFT+ :)		14.02.2001	15.02.2001								
(13)Tid (CTRL+SHIFT+ :)		14:26	15:34								
(14)Beregning fra veiing:											
(15)Barometertrykk ved veiing, hPa:		1011,92	1013,14								
(16)Barometertrykk i perioden, hPa:		1013	1011,2								
(17)Temperatur luft over boks, °C:		23	23,6								
(18)Temperatur i saltløsning, °C:		23	23,6								
(19)RF i rommet, %		50	50,8								
(20)Veiing nummer:		1	2	3	4	5	6	7	8	9	10
(21)Vekt.g kontrollodd før veiing:		999,997	999,996								
(22)Vekt.g prøve nr:	1	761,385	761,427								
(23)Vekt.g prøve nr:	2	741,910	741,949								
(24)Vekt.g prøve nr:	3	668,128	668,169								
(25)Vekt.g prøve nr:	4	750,151	750,170								
(26)Vekt.g prøve nr:	5	709,292	709,323								
(27)Vekt.g kontrollodd etter veiing:		999,997	999,999								

Example figures

Appendix 4

Beregnet vanddampovergangsmotstand
etter Welty, James R., *Fundamentals of Momentum, Heat and Mass Transfer*
se forutsetninger på eget ark

