



## **EFFLOCOM**

Energy efficiency and load curve impacts of commercial development in competitive markets

**EU/SAVE 132/2001**

---

### **Results from the EFFLOCOM Pilots**

---

<b>Date:</b>	<b>2004-06-30</b>
<b>Report ID</b>	<b>EU/SAVE 132/01 EFFLOCOM report no. 7</b>
<b>Class:</b>	<b>Deliverable</b>
<b>Reported by:</b>	<b>VTT</b>
<b>Contact person:</b>	<b>Seppo Kärkkäinen (email: seppo.karkkainen@vtt.fi)</b>
<b>Distribution:</b>	<b>EC Restricted</b>



## EFFLOCOM Partners:

SINTEF	Partner 1 / Coordinator	Norway
(Electricity Association (EA) *)	Partner 2	England)
VTT	Partner 3	Finland
Energy piano	Partner 4	Denmark
EDF	Partner 5	France
E-CO Tech	Partner 6	Norway

\*) Withdrawn from the project by 31 July 2003

## Contributors to this report:

Seppo Kärkkäinen, VTT  
Jussi Ikäheimo, VTT  
Casper Kofod, Energy piano  
Denise Giraud, EDF  
Håvard Nordvik, E-CO Tech  
Ove S. Grande, SINTEF Energy Research



## Table of Contents

<b>1</b>	<b>OBJECTIVES OF THE PILOTS .....</b>	<b>9</b>
<b>2</b>	<b>DANISH PILOT PROJECT: DEMAND RESPONSE OFFERED BY HOUSEHOLDS WITH DIRECT ELECTRIC HEATING .....</b>	<b>13</b>
2.1	INTRODUCTION.....	13
2.2	DESCRIPTION OF THE PROJECT.....	13
2.2.1	<i>Objectives</i> .....	13
2.2.2	<i>Partners and co-operation</i> .....	13
2.2.3	<i>Technology</i> .....	14
2.2.4	<i>Methodology</i> .....	16
2.3	RESULTS.....	18
2.3.1	<i>Temperature and electricity market during the winter 2003/04</i> .....	18
2.3.2	<i>Load reduction by demand response</i> .....	18
2.3.3	<i>Energy and cost savings for the customers</i> .....	22
2.3.4	<i>Assessment of enabling technologies</i> .....	22
2.3.5	<i>Cost/Benefit analysis in medium scale</i> .....	23
2.3.6	<i>Customer survey</i> .....	25
2.3.7	<i>Barriers</i> .....	25
2.4	CONCLUSIONS AND EVALUATION OF RESULTS.....	26
<b>3</b>	<b>FINNISH PILOT: EFFECT OF WEB-BASED FEEDBACK ON THE ELECTRICITY CONSUMPTION AND LOAD CURVES.....</b>	<b>27</b>
3.1	DESCRIPTION OF THE PILOT .....	27
3.2	ACHIEVED RESULTS AND KEY FIGURES.....	28
3.2.1	<i>The Kulunet service</i> .....	28
3.2.2	<i>Available data</i> .....	30
3.2.3	<i>Consumption dependencies</i> .....	31
3.2.4	<i>Grouping of the real estates</i> .....	35
3.2.5	<i>Availability and utilization of feedback</i> .....	37
3.2.6	<i>Consumption changes since summer 2003</i> .....	41
3.2.7	<i>Real estates which had active experts</i> .....	46
3.2.8	<i>Group-specific changes in REC</i> .....	51
3.3	MONITORING OF HOUSING LOADS USING FORECASTS .....	51
3.3.1	<i>The real estate loads</i> .....	51
3.3.2	<i>General principle of EME Forecast</i> .....	52
3.3.3	<i>Using EME Forecast as a load monitor</i> .....	52
3.3.4	<i>EME Forecast test results</i> .....	53
3.4	RESULTS FROM THE OPINION POLL .....	56
3.5	CONCLUSIONS .....	57
<b>4</b>	<b>FRENCH PILOT: TEMPO: A REAL-TIME TARIFF FOR EDF MASS-MARKET CUSTOMERS60</b>	
4.1	THE CONTEXT.....	60
4.2	STEP 1 – EXPERIMENTATION WITHIN THE RESIDENTIAL SECTOR.....	61
4.3	STEP 2 - LAUNCHING.....	62
4.3.1	<i>From an economic point of view</i> .....	62
4.3.2	<i>From a technical point of view</i> .....	62
4.3.3	<i>From a commercial point of view:</i> .....	63
4.3.4	<i>The feedback after 3 years</i> .....	64
4.3.5	<i>Conclusion of the launching step</i> .....	65
4.4	STEP 3 – GENERALIZATION TOWARD ALL MASS MARKET CUSTOMERS.....	65
4.4.1	<i>Evolution of the number of tempo customers</i> .....	65
4.4.2	<i>Feedback</i> .....	66

4.5	CONCLUSION: TEMPO HAS BEEN ADAPTED TO A MONOPOLISTIC CONTEXT AND NOT TO AN OPEN MARKET.....	66
<b>5</b>	<b>NORWEGIAN PILOT 1: IMPLEMENTATION OF DEMAND SIDE MANAGEMENT IN OSLO</b>	<b>69</b>
5.1	INTRODUCTION.....	69
5.2	PROJECT OVERVIEW .....	69
5.2.1	<i>Objectives and summary of project facts.....</i>	69
5.2.2	<i>Project angle and methodology.....</i>	71
5.2.3	<i>Identifying bottlenecks.....</i>	72
5.2.4	<i>Motivation and energy auditing.....</i>	73
5.2.5	<i>Load profile analysis.....</i>	74
5.2.6	<i>Evaluation.....</i>	74
5.3	PILOT TEST 1- RESIDENTIAL CUSTOMERS: IMPLEMENTATION OF LOCAL LOAD CONTROL OF WATER HEATERS IN 156 BLOCK OF FLATS.....	75
5.3.1	<i>Description of solution and technology.....</i>	75
5.3.2	<i>How to involve the customers.....</i>	77
5.3.3	<i>Barriers experienced.....</i>	77
5.4	PILOT TEST 2- RESIDENTIAL CUSTOMERS: IMPLEMENTATION OF SMART HOUSE CONCEPT IN 17 ROW HOUSES.....	78
5.4.1	<i>Description of solution and technology.....</i>	78
5.4.2	<i>Description of solution and technology.....</i>	78
5.4.3	<i>How to involve the customers.....</i>	80
5.4.4	<i>Barriers experienced.....</i>	81
5.5	PILOT TEST 3 - COMMERCIAL CUSTOMERS: IMPLEMENTATION OF VARIOUS ENERGY EFFICIENCY ACTIONS WITHIN A CERTAIN CITY AREA.....	81
5.5.1	<i>Description of solution and technologies.....</i>	82
5.5.2	<i>How to involve the customers.....</i>	83
5.5.3	<i>Barriers experienced.....</i>	84
5.6	PROJECT RESULTS AND KEY FIGURES.....	87
5.6.1	<i>Residential customers.....</i>	87
5.6.2	<i>Commercial customers.....</i>	88
5.7	CONCLUSIONS AND EVALUATION OF RESULTS.....	93
<b>6</b>	<b>NORWEGIAN PILOT 2: NEW TECHNOLOGY FOR CONTROLLING POWER LOADS IN OSLO</b> .....	<b>94</b>
6.1	INTRODUCTION.....	94
6.2	OBJECTIVES AND SUMMARY OF PROJECT FACTS .....	94
6.3	PROJECT ANGLE AND METHODOLOGY .....	95
6.4	PILOT TEST - COMMERCIAL CUSTOMERS: IMPLEMENTATION OF REMOTE CONTROL OF DIFFERENT LOADS IN LIMITED TIME PERIODS .....	98
6.4.1	<i>Description of solution and technology from the Network Company point of view.....</i>	99
6.4.2	<i>Description of solution and technology for the customers.....</i>	101
6.4.3	<i>How to involve the customers.....</i>	115
6.5	BARRIERS EXPERIENCED .....	117
6.6	PROJECT RESULTS AND KEY FIGURES.....	120
6.7	CONCLUSIONS .....	121
<b>7</b>	<b>NORWEGIAN PILOT 3: END-USER FLEXIBILITY BY EFFICIENT USE OF ICT.....</b>	<b>122</b>
7.1	INTRODUCTION.....	122
7.2	PROJECT OVERVIEW .....	122
7.2.1	<i>Objective of the pilot.....</i>	122
7.2.2	<i>Technology requirements and implementation .....</i>	122
7.2.3	<i>Description of the customers.....</i>	123
7.2.4	<i>Power Shortage characteristics .....</i>	123
7.2.5	<i>Criteria of automatic load reduction.....</i>	124
7.2.6	<i>Network tariffs.....</i>	124
7.2.7	<i>Power contract offered.....</i>	125
7.2.8	<i>Project activities and time schedule for accomplishment.....</i>	126

7.3	ACHIEVED RESULTS AND KEY FIGURES.....	126
7.3.1	<i>Customer agreements</i> .....	126
7.3.2	<i>Technology</i> .....	128
7.3.3	<i>Experiences with the technology</i> .....	129
7.3.4	<i>Large scale pilot tests – Achieved results</i> .....	130
7.3.5	<i>Cost/benefit analysis</i> .....	134
7.4	CONCLUSION AND RECOMMENDATIONS .....	135
<b>8</b>	<b>CONCLUSIONS AND RECOMMENDATIONS FROM THE PILOTS .....</b>	<b>136</b>



## **1 Objectives of the Pilots**

Phase 4 of the EFFLOCOM project is dealing with the problem of how to remove barriers for energy efficiency and load curve impacts in competitive market. In practice Phase 4 quantifies the potential for load impacts related to Smart-house technology, dynamic tariffs and web based energy efficiency information through pilot studies.

According to the project plan phase 4 will consist of several different pilot cases studying different means to improve energy efficiency:

1. *Smart-house technology*: A Smart-house system involving central load management based on Internet will be tested out with commercial customers. The potential for energy reduction and peak power reductions will be estimated for the customers prior to the testing in order to target the pilot study to the appliances with the largest potential. Relevant appliances include electric boilers, heating cables, processing plants and ventilation. In addition, a tool that will be developed and tested undertakes end use metering at domestic appliances. A questionnaire among 25 domestic customers that have participated in a home automation project including DSM incentives will be evaluated.
2. *Dynamic tariffs*: Analysis of the load profiles from a sample composed of 450 customers with the tempo tariff over a period of 4 years. Customers with the dynamic tempo tariff are measured by 10-minute intervals. In addition the project will include TOU tariffs for larger customers. For nearly 10 years larger customers in Denmark has used time of day tariffs with shifting between peak, shoulder and valley prices over the year, week and day. Experience on which customers benefit from this kind of tariff will be analysed.
3. *Web based energy efficiency information*: Two different types of web based energy efficiency services will be tested in the project. Customers can follow their consumption on the web. One of the systems includes comparison of different offers where the customer can change supplier.

The following chapters describe the actual pilots related to the above means in Denmark, Finland, France and Norway.

Table 1 gives the summary of the pilots.

Table 1. Summary of the pilots

Pilot/objectives/technologies	Responsible Partner
<p><b>Demand Response offered by households with direct electric heating</b></p> <p><i>The objectives of the Danish pilots are to increase the end-user flexibility in periods with scarcity of electrical energy and power by:</i></p> <ul style="list-style-type: none"> <li>• <i>Establishing a decision basis and suggest external conditions for a prioritised building of an infrastructure based on IT-solutions for direct communication and demand response.</i></li> <li>• <i>Develop, test and evaluate incentives, which stimulates flexibility in consumption, with basis in an economical bonus (to be a part of a power price tariff) and implementation of IT in order to facilitate the customers acting and knowledge on their consumption.</i></li> </ul> <p><i>Technology is based on</i></p> <ul style="list-style-type: none"> <li>• <i>Two-way communication (GPRS<sup>1</sup>, Internet)</i></li> <li>• <i>Remote meter reading and smart house</i></li> <li>• <i>Web</i></li> </ul>	Energy Piano
<p><b>Effect of web-based feedback on the electricity consumption and load curves</b></p> <p><i>The main objective of the pilot is to study what effect the improved extranet-based information on energy consumption has in the real-estate and household electricity consumption in terraced houses and in the block of flats.</i></p> <p><i>Technology is based on</i></p> <ul style="list-style-type: none"> <li>• <i>Remote meter reading of hourly data of total electricity consumption and real estate electricity consumption (household consumption can be calculated) as well as of water and heat (district heat) consumption.</i></li> <li>• <i>Extranet-based feedback on consumption is given to building</i></li> </ul>	VTT

---

<sup>1</sup> GPRS = General Packet Radio Service

Pilot/objectives/technologies	Responsible Partner
<i>energy managers and partly also to final consumers</i>	
<p><b>Tempo: a real-time tariff for EDF mass-market customers</b></p> <p><i>The main objective is to study the effect of the dynamic tariff “Tempo” on the electricity consumption. The Tempo option divides the year into three types of random days: 300 blue days (the least expensive), 43 white days (medium price), and 22 red days (the most expensive). Each day is divided into two fixed periods: peak hours (day) and off-peak hours (night). The colour of the day is chosen by the national operating system at the end of each day for the next day.</i></p> <p><i>Technology of the pilots include</i></p> <ul style="list-style-type: none"> <li>• electronic meters</li> <li>• a notification equipment fit to inform the customer about the tariff of the present day and of the day after</li> <li>• energy management systems</li> <li>• ripple control (one-way communication technique for sending tariff signal using the electric power lines).</li> </ul>	EDF
<p><b>Implementation of Demand Side management in Oslo</b></p> <p><i>Main objectives are</i></p> <ul style="list-style-type: none"> <li>• <i>to avoid/expose planned grid reinforcement with use of DSM (energy efficiency actions) and</i></li> <li>• <i>to increase knowledge about electricity end-users behaviour and compose a motivation model that can be used by the grid-owner and his coadjutant partner for energy economising.</i></li> </ul> <p><i>Technology includes</i></p> <ul style="list-style-type: none"> <li>• <i>the smart house solution based on Internet and wireless radio communication and</i></li> <li>• <i>the Ebox “plug and play” units implemented among residential end-users containing a switch, a radio receiver, a thermostat and a clock.</i></li> </ul>	ECO-Tech
<p><b>New technology for Controlling of Power load in Oslo</b></p> <p><i>The main objective of the project is to initiate remote controlling of minimum 2 MW uninterruptible power load among various categories of commercial customers. The grid owner shall initiate implementation of necessary actions among the commercial end users through offering new tariffs related to controllable or interruptible load.</i></p> <p><i>Necessary actions will be implementation of new technology for smart</i></p>	ECO-Tech

<b>Pilot/objectives/technologies</b>	<b>Responsible Partner</b>
<p><i>house and building automation or other solutions for remote control of single power loads. The project shall also gain knowledge concerning “what makes the end user carry out the necessary actions?”</i></p>	
<p><b><i>Improvement end-user flexibility by efficient use of ICT</i></b></p> <p><i>The objective of the project is to increase the end-user flexibility in periods with scarcity of electrical energy and power by</i></p> <ul style="list-style-type: none"> <li><i>• Establishing a decision basis and suggest external conditions for a prioritised building of an infrastructure based on ICT-solutions for direct communication and load management.</i></li> <li><i>• Develop, test and evaluate different incentives, which stimulates to flexibility in consumption, with basis in network tariff, power prices and other market solutions.</i></li> </ul> <p><i>The technology of the project involves establishment of Direct Communication (two-way communication), including hourly metering and separate channel for remote control, to altogether 10 000 customers in 2 different network areas.</i></p>	SINTEF

## **2 Danish Pilot project: Demand Response offered by households with direct electric heating**

### **2.1 Introduction**

The Danish pilot project Demand Response offered by households with direct electric heating sponsored by Elkraft System and ELTRA is a part of the EU SAVE project EFFLOCOM. Results and conclusions from the pilot project are described below.

### **2.2 Description of the project**

#### **2.2.1 Objectives**

The peak power balance in the Nordic power system is gradually turning to be very tight. Hardly any investments in new production are carried out. For this reason focus has turned towards emphasis to encourage manual or automatic demand response, which implies need for hourly metering for documentation, and controllability in order to meet the response requirements.

A Danish demand response pilot project was established in 2003 including 25 domestic homes with direct electrical heating. Enabling technologies include extra customer installations with control and remote reading by GPRS communication and customer services provided at the Internet.

The objectives of the Danish pilot project is to increase the end-user flexibility in periods with scarcity of electrical energy and power by:

- Establishing a decision basis and suggest external conditions for a prioritised building of an infrastructure based on IT-solutions for direct communication and demand response.
- Develop, test and evaluate incentives, which stimulates flexibility in consumption, with basis in an economical bonus (to be a part of a power price tariff) and implementation of IT in order to facilitate the customers acting and knowledge of their consumption.

#### **2.2.2 Partners and co-operation**

Figure 1 describes the major activity in the pilot project from Spring 2003 to Summer 2004.

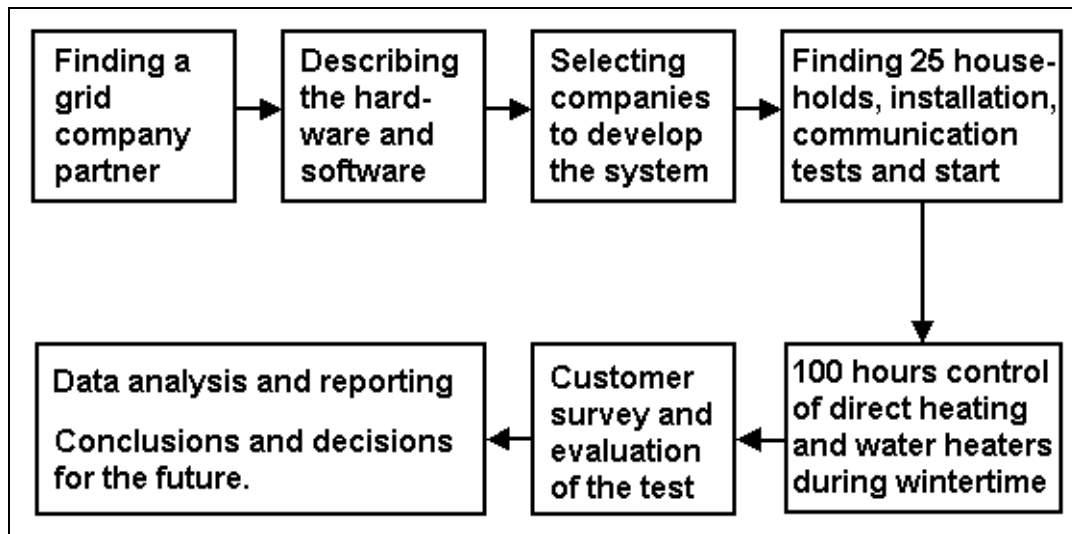

Figure 1. Major activity in the Danish pilot project

The network company SEAS serving a large area of East Denmark decided to participate. In the pilot project, SEAS has been responsible for customer selection and installation of the equipment.

SEAS invited around 450 households with direct electric heating and a consumption of 12-16,000 kWh to participate. Around 45 customers answered quickly they would like to participate. After inspection, around 12 of the customers were found not to be suitable due to bad GPRS connection or because the installation was difficult and expensive to access. Among the rest, customers with heat stove and low kWh/m<sup>2</sup> consumption were selected because they were assumed to have more flexibility in the consumption.

Based on the description of the system (hardware and software), six manufacturers offered their solution all including some new development. Three manufactures were selected for personal presentation. The Danish manufacturer Amplex A/S gave the best offer and was selected as hardware provider including communication by GPRS and Internet. The software company IT Energy was selected for development of a Web report providing the customer with actual detailed data on their electricity consumption and the bonus they have saved by the demand response activity.

Energy piano have managed development, implementation, customer contact, data analysis, evaluation and reporting with reference to and co-operation with the two Danish TSOs Elkraft System and ELTRA.

### 2.2.3 Technology

The 25 households with electric heating received an extra installation for load control, detailed metering of the heating consumption and remote reading.

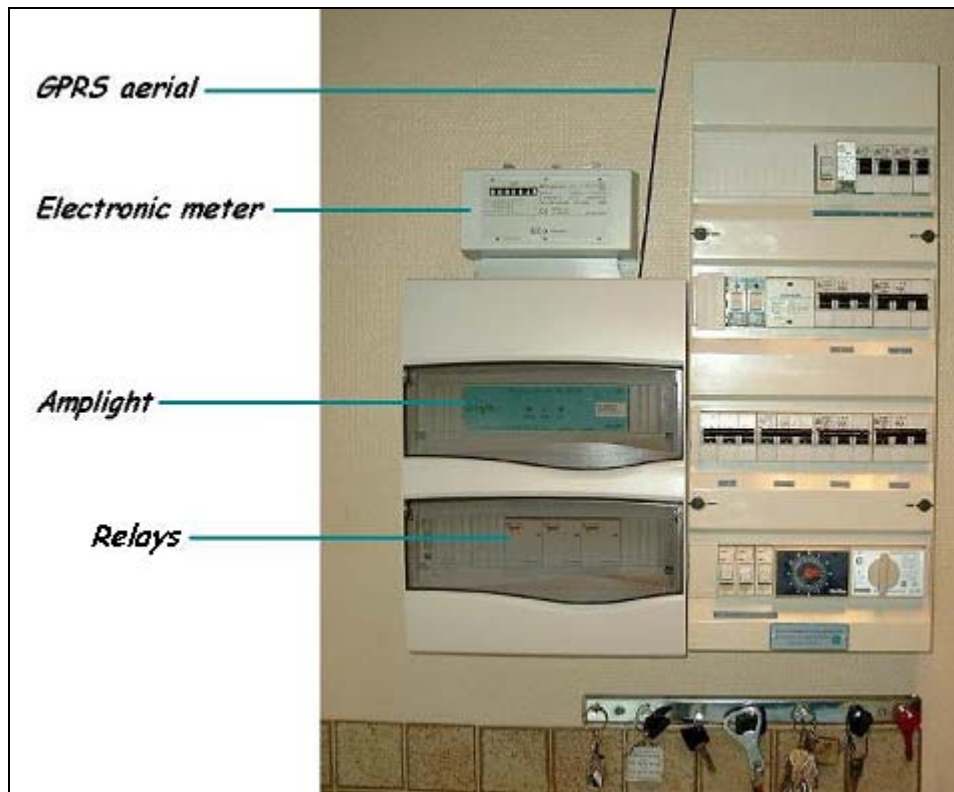

Figure 2. Household installation

The left hand side of Figure 2 shows the new pilot project installation including:

- A small electronic meter recording and storing the heating electricity consumption every quarter of an hour.
- The Amplight providing the opportunity for individual control of five zones/appliances. For GPRS communication to the unit is a small aerial placed at the indoor roof.
- Relays for up to five control zones.

The high-speed mobile phone net GPRS is used for:

- automatic demand response control for up to five control zones/appliances.
- Daily remote meter reading of the total electricity heating consumption per quarter of an hour.

The customer communicate with the system by Internet. The Web site includes:

- Access to setting the limits for the maximum duration of interruption for up to five different control zones for different time periods of the day.
- Access to stop an actual interruption for some of or all the control zones.
- A report on the daily, weekly and monthly use of electricity and the saved bonus by demand response control.

Figure 3 shows the full IT configuration for the Danish pilot project.

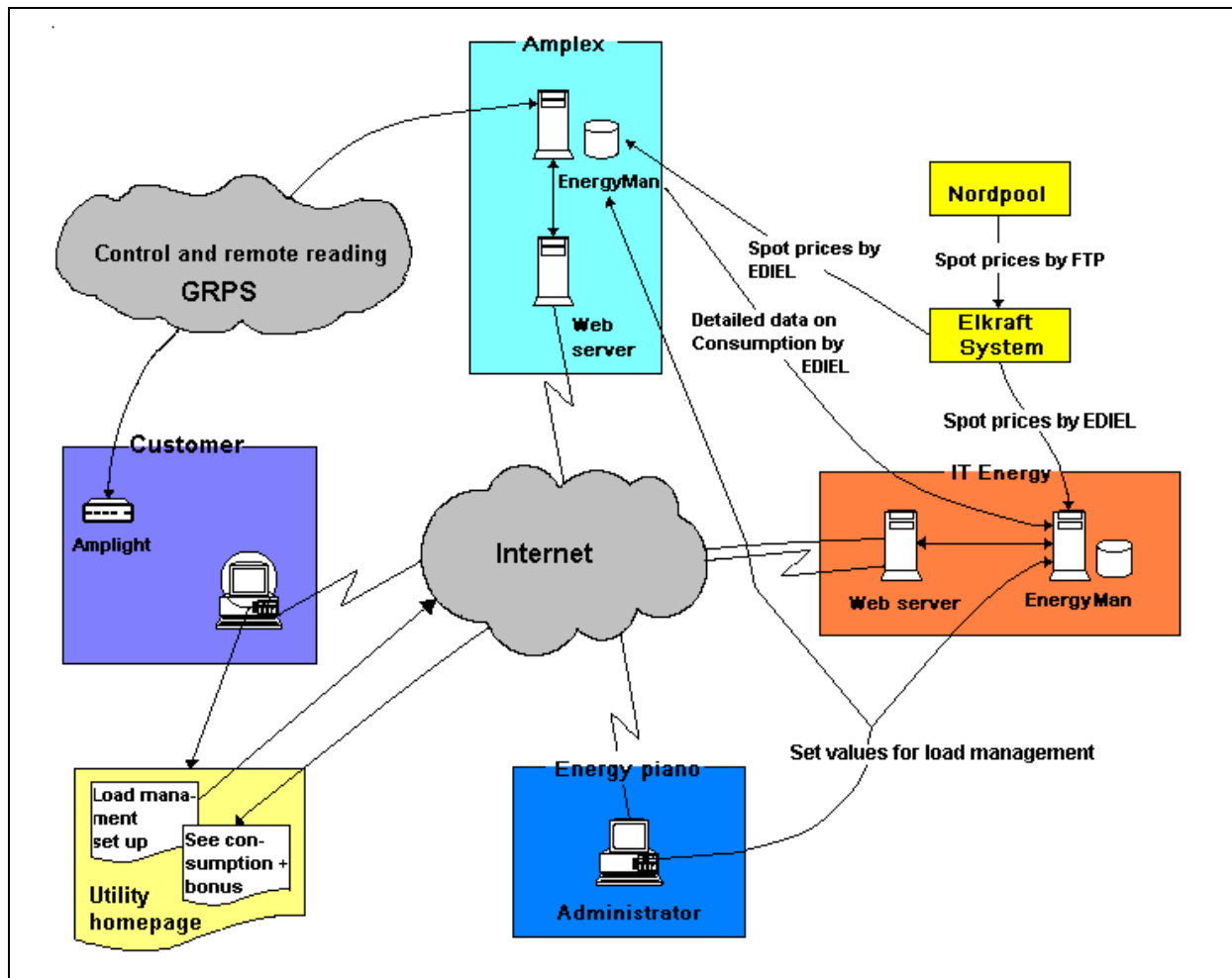

Figure 3. IT configuration in the Danish pilot project

## 2.2.4 Methodology

Nord Pool – The Nordic Power Exchange – is the world's first international commodity exchange for electrical power organizes trade in standardized physical (Elspot) and financial power contracts. The day before, the hourly Elspot prices are settled based on power offers and expected demands given in by all producers and suppliers at the market.

The system is designed for activation when the Nord Pool hourly Elspot prices exceed the price level set by the utilities and the TSO. Actually, a year contains around 10 hours with very high spot prices. In the pilot project is simulated a probable near future situation with an extended potential for demand response including 100 hours per year.

The highest 100 spot prices appear typically on working days and in the two time periods: 06-11 and 16-19 hours. This is thus the time when the interruptions have been made in the pilot project.

The communication by the high-speed mobile phone net GPRS is wireless and nation-wide and does not assume any investments in infrastructure. As shown in Figure 4, the system might control groups of loads and include remote meter reading at different voltage levels in

order to follow the influence of the demand response control and avoid return load higher than the grid and/or system can supply.

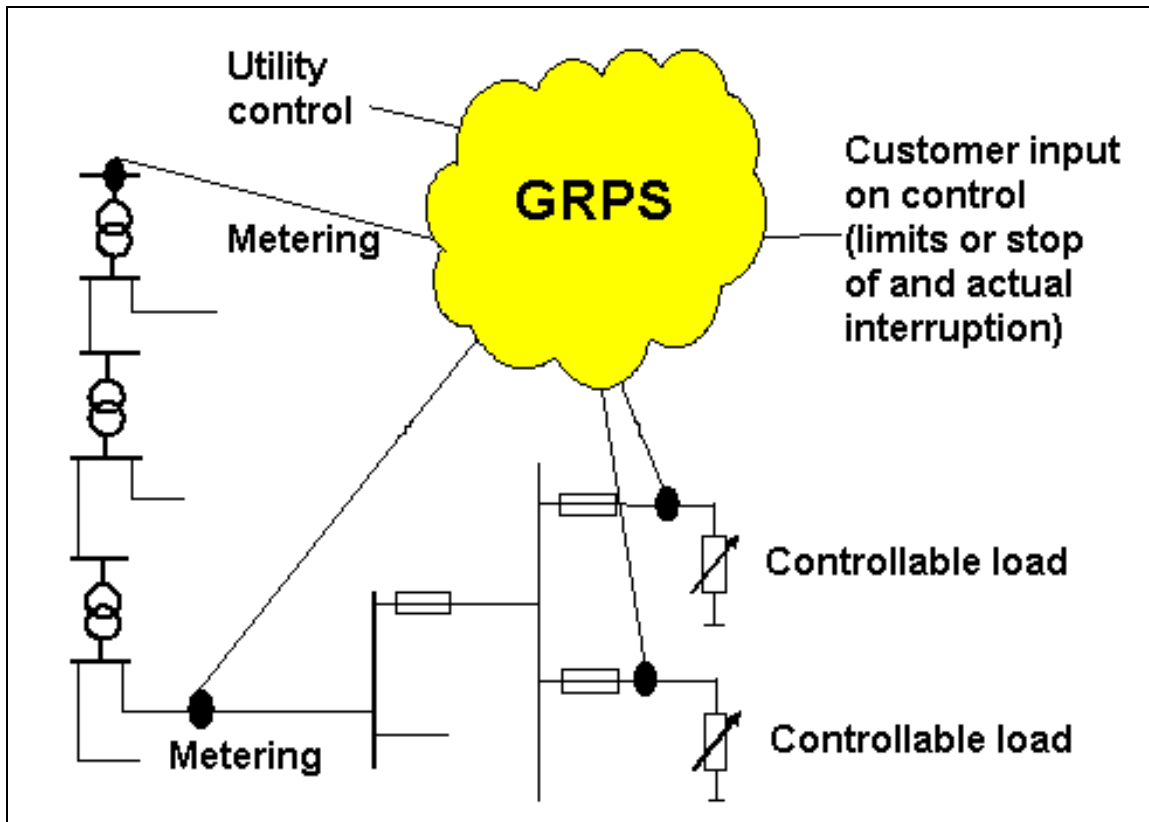

Figure 4. Control by wireless GPRS communication

In the project, the economical incentives for demand response are higher than the actual level. This simulates a possible scenario within a few years. The customer load curves without control are used as reference to find the influence of demand response.

The bonus in the 100 hours of control varied between 0.13, 0.27 and 0.40 Euro/kWh for the electricity consumption interrupted in order to find the customer response depending on the size of the bonus.

For practical reasons the customer savings by demand response were paid to the customer separate from the billing. This had the side benefit of giving more exposure on the savings.

## **2.3 Results**

### **2.3.1 Temperature and electricity market during the winter 2003/04**

October - December 2003 were relatively warm with no real winter temperatures with a Nord Pool spot-market being very calm with stable low prices. From beginning of January 2004 the winter started with some limited price variation at the market.

During the month of January it became clear that the intention of simulating a near future development at the market place by transferring the actual spot prices to a situation with 100 hours demand response hours based on market experience from last winter was not possible due to a very different market situation.

Due to different market situation, the strategy was changed to systematic testing of interruptions at different time of day and of duration.

### **2.3.2 Load reduction by demand response**

At the days of interruption, the average daily temperature has been from  $-8$  C up to  $11$  C with a respective interrupted heating load from  $5.3$  to  $2.5$  kW/house. Figure 5 shows the peak days.

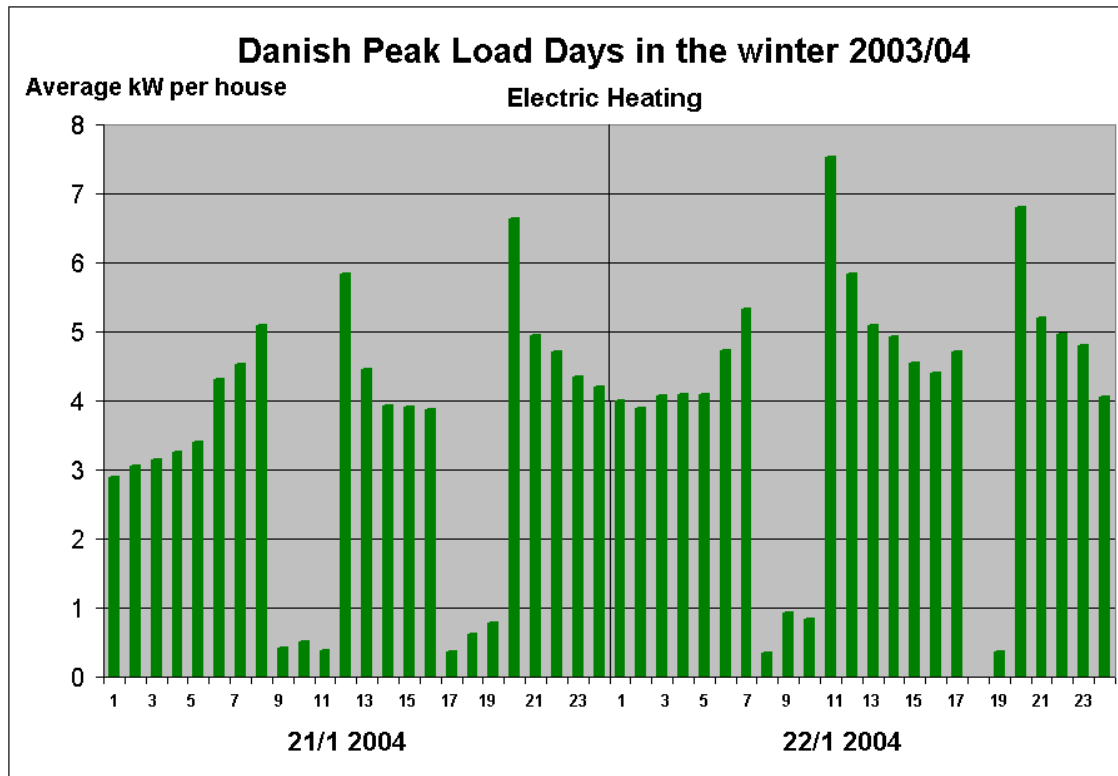

Figure 5. Daily load curves for the two peak load days.

The customers were selected due to a yearly consumption above 16,000 kWh/year. Figure 5 excludes customers that have reduced their consumption in 2003/2004 e.g. due to use of a new wood stove.

Figure 6 shows the peak load day with control and without control (simulated since there was no other days with daily average temperature down at  $-7.8^{\circ}\text{C}$ ). Besides the load reduction at the convenient time for the total electricity system the customer do also save electricity as a consequence of the control.

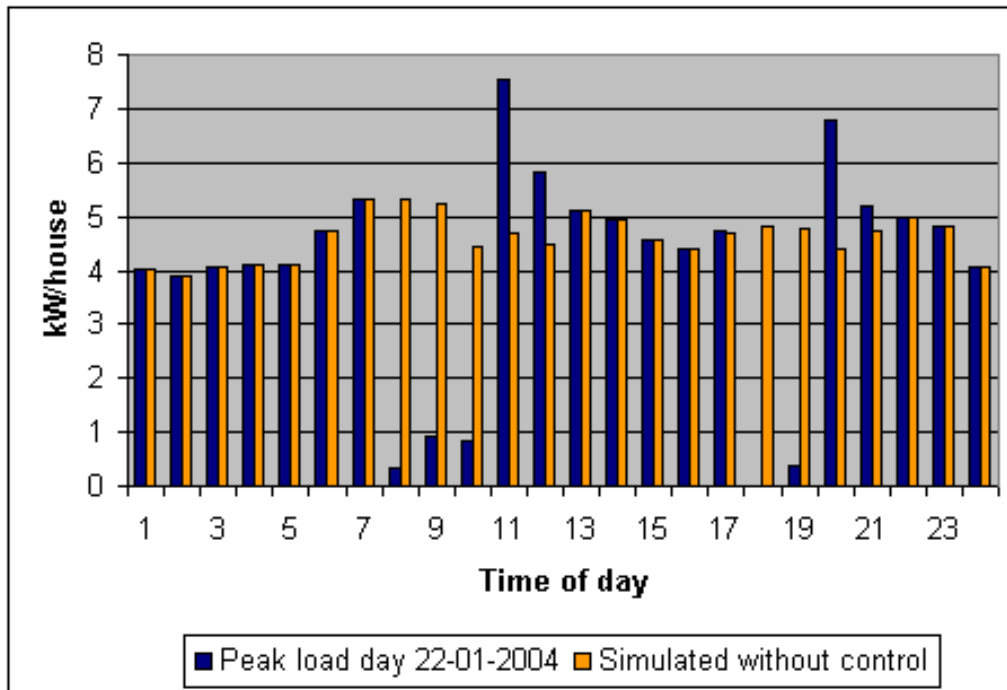

Figure 6. Peak load day 22 January 2004

By use of the project homepage the customers were able to stop an interruption in case of inconvenience. Results concerning use of this facility are:

- 10 of the 25 customers have used this facility
- of the 10 customers have only used the facility one time
- of the 10 customers have only used the facility two times
- The last 3 have used the facility respectively 6, 16 and 18 times.
- The customers have used to facility selectively only stopping the interruption for some of the zones.
- The facility has been used for all times of day.

The customers had another homepage facility giving access to setting limits for the maximum duration of an interruption for the different control zones, time periods of the day and three sizes of the bonus. An example is shown in Figure 7.

Results concerning use of this facility are:

- 6 of the 25 houses have used this facility. The remaining have accepted the default value of maximum 3 hours interruption for all zones, time of day and level of bonus.
- No customers differentiated on the level of bonus.
- The set up of the 6 customers were individual: one family could not accept any interruption of the water heater, another family could only accept an interruption of the direct heating one hour in the evening while there was no limitations in the morning.

Setup	Bonus pr. removed kWh					
	1 kr.		2 kr.		3 kr.	
	Time zone		Time zone		Time zone	
	6-11	16-19	6-11	16-19	6-11	16-19
In the table beside including different two time zones and 3 levels of bonus, please specify your accepted maximum length of an interruption.						
Bed rooms and hall	1	3	2	3	3	3
Dining room and kitchen	3	1	3	3	3	3
Living room and office	3	1	3	2	3	3
Water heater	3	3	3	3	3	3
Bath room and guest room	3	3	3	3	3	3

1. kr. = 0.133 Euro

Figure 7. Example of setting maximum duration for interruptions

Regression analysis on the total consumption for electric heating in the houses have resulted in a good description of the average consumption per house by a rather simple model:

$$\text{Con}_{\text{hour}} = 0,457 + (0,171 - 0,180 \cdot \text{Interrupt} + 0,081 \cdot \text{Return} - 0,0420 \cdot \text{Night}) \cdot \text{DDV}$$

Where

$\text{Con}_{\text{hour}}$  is the average consumption per hour in daytime (07-24 hours) or night (00-06 hours)

Interrupt is 1 at times when an interruption is taking place and 0 the rest of the time

Return is a description of the return load on the hours after an interruption

Night is 1 in the day period 00-06 hours and 0 the rest of the time

DDV is a degree day variable calculated as an average of degree days for the last 24, 28 and 72 hours. Degree days are defined as: 17 - the average daily temperature.

The adjusted  $R_2$  value for the model is 80% telling that 80% of the variation can be explained by the model. All variables are significant.

Below is an example on use of the model: At day of  $-3^{\circ}\text{C}$ :

- The average daily load =  $0,457 + 0,171 \cdot 20 = 3,9$  kW/house.
- The load during an interruption =  $0,457 + (0,171 - 0,180) \cdot 20 = 0,3$  kW/house
- The load the first hour after an interruption (Return is set to 0,5 in the first hour after an interruption) =  $0,457 + (0,171 + 0,08 \cdot 0,5) \cdot 20 = 4,7$  kW/house

The model stays the same whether or not the customers use wood stoves as a supplementary heating. The model tells that only 45% ( $0,081/0,180$ ) of the interrupted consumption is consumed in order to get the temperature back to the required level. This is assumed to be a result of less loss of heat when the temperature falls during interruption, but is more than expected.

### **2.3.3 Energy and cost savings for the customers**

Customer bonus by demand response in the winter 2003/04 were in average 80 Euro/customer. Before start of the pilot project was calculated that the bonus might be up to 130 Euro/customer. The relatively mild winter resulted in lower loads in the 100 hours interruption than if we have had a winter with more cold days.

As mentioned the data analysis shows that only 45% of the interrupted consumption is used afterwards to bring the temperature back to the required level. Assuming that the interrupted load is in average 3,3 kW (equal to an average temperature of 0<sup>0</sup>C) this gives a saving of 3,3 kW \* 100 hours \* 55% = 180 KWh equal to 40 Euro/customer.

The economical benefit for the customer were thus in total 80+40 = 120 Euro/year.

### **2.3.4 Assessment of enabling technologies**

The Amplight system for control and remote reading have been working very well.

The GPRS system was found to be a little weak in one area resulting in that three houses did not receive all calls for interruption in the first month of the experiment. Amplex A/S raised the problem for the GPRS provider resulting in improvement. During the next years GPRS is expected to cover all parts of Denmark since the new mobile phones are using GPRS.

Due to the GPRS problems for a few houses, extra security was build into the software managing the Amplight system including:

- Start and stop of an interruption is send in the same message to all the controllable units.
- Repetition of sending messages.
- Automatic control every late evening that every controllable is switched on.
- Ensuring that the time of interruption and recording 15 min consumption is synchronized.

We are having perfect time series of consumption per quarter of an hour and hour for all 25 houses!

The installation work was done with quality and looked very nice as shown in figure 2. Only two small adjustment of installations have been necessary.

The home page giving different kind of services to the customers has been working all the time.

### 2.3.5 Cost/Benefit analysis in medium scale

The Danish pilot doesn't include a full cost/benefit analysis including cost and benefits for Customer, network owner, supplier, system operator and society.

The pilot includes a comparison of the flexible load to investment in further production to be used in the few hours where it is difficult to meet the demand.

Based on actual costs in the pilot and evaluation with the manufactures of hardware and software as well the installers, the cost of equipment, software and installation is evaluated to be 800 Euro per house in case the installation includes 1000 houses. The pilot shows that 5 kW/house can be interrupted at cold days. Assuming that the 5 kW/house also counts for the 1000 houses, the investment is equal to 160 Euro/kW or 31 Euro/kW per year (10 years, 7%).

As a comparison, the investment for gas turbines is around 80 Euro/kW per year (10 years, 7%). This analysis thus indicates that investment in flexible load is a good investment.

The customers in the pilot have during the winter 2003/2004 in average saved 80 Euro by offering flexible loads for electric heating and on top of they have in average obtained 40 Euro in energy savings. In case the control system also comes to include customer facilities for lowering (interrupting) the heating in periods during the day and/or night, the benefits for the customer are estimated to be much higher. The customer may thus be willing to pay a part of the investment in equipment, software and installation.

Next generation of the technology gives access to management of the single heating unit and appliance with more customer flexibility and integration as shown in Figure 8.

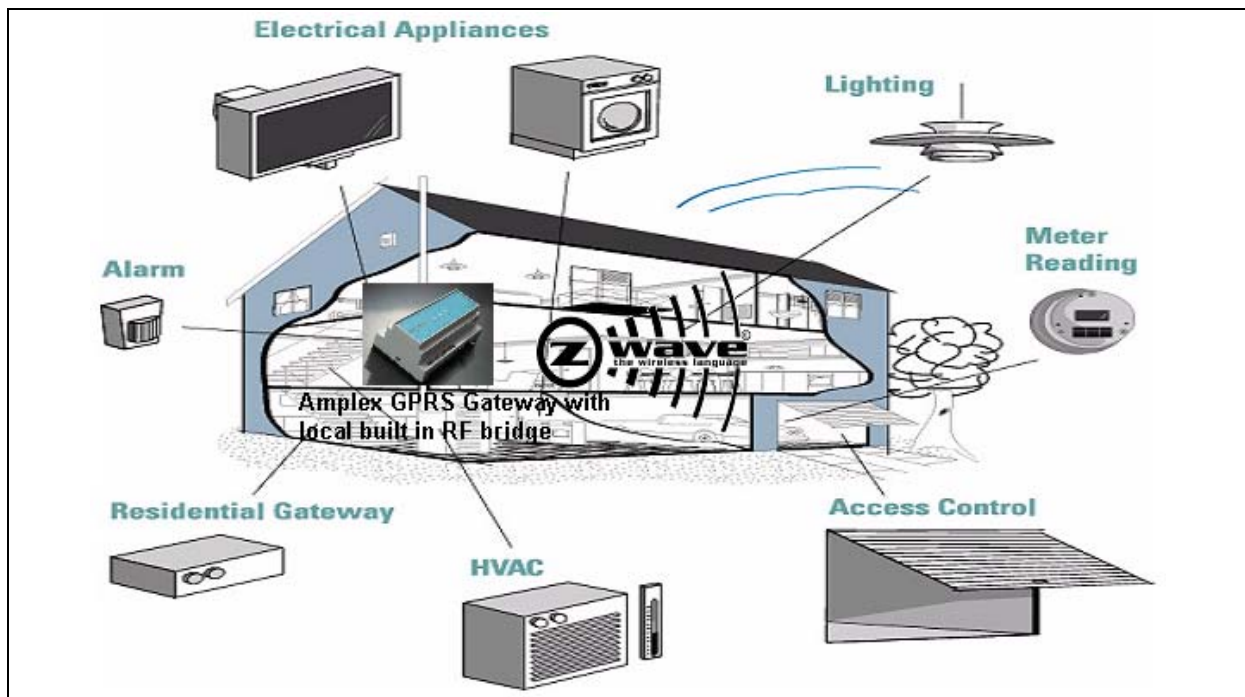

EFFLOCOM: Energy Efficiency and load Curve Impact of Commercial Development in Competitive markets

*Figure 8. Next generation of the demand response system from Amplex A/S*

Customer saving/benefits are found to be around 120 Euro per year (se part 1.3.3).

### **2.3.6 Customer survey**

A detailed customer survey have been performed after ending the interruption for the winter 2003/2004. Results are:

- The customers have used the homepage to follow the development in their consumption on a weekly or monthly.
- Customers find curves and key figures on the development in the consumption as well as the bonus per day, week and months interesting.
- The customers find the homepage facilities are easy to use.
- Most customers are “satisfied” or “nearly satisfied” with the size of the bonus they have gained by participating the project. Only a few customers are “not satisfied” with the level of their bonus.
- Some customers suggest to include the dishwasher, the washing machine and the tumbling machine in the management.
- The customers who have used the facility to stop an interruption find it easy to use and could feel the heating coming back within a few minutes.
- Nearly all customers state that they can live with interruptions of three hours duration.
- Half of the customers own a wood stove which in most cases have been in use more or less during the interruptions. These customers are thus more flexible.
- No customers have been using extra portable electric heating ovens at cold days during the winter.
- Most customers would like the system to include possibilities for lowering the heat in the night although one customer already having a system for this note that it is not possible to have lowering of the heat up till 06 hours followed by a demand response interruption. The management thus have to be integrated. There might also be possibilities for lower the heating in the middle of the day in case nobody is at home at this time.
- All customers would recommend other customers to use the system.
- All customers would like to continue next winter!

### **2.3.7 Barriers**

Very few Danish customers have an energy price which is related/follows the spot price in the competitive Nordic electricity market, Nord Pool. The existing tariff agreement for most customers thus does not contain an incentive for demand response.

Payment for electricity in Denmark consists of three parts:

- Energy price from the supplier.
- Network tariff from the network company. Besides payment for use of the network the network company also collect payment for environmental production (windmills and smaller combined heat/power plants) and payment for the TSO.

- Taxes which makes more than 50% of the total payment for smaller customers.

Questions to adress are:

- How is demand response on a large scale going to be organised?
- What is the role of the TSO, the supplier, the network company and the installer and maybe a performance contractor having contact to the customer?
- What kind of tariff of agreement gives different end-users the best incentive?
- What kind of limitations for load control do different end users with different consumption have?
- What durability and frequency of interruption do other types of customers accept?

## **2.4 Conclusions and evaluation of results**

The yearly peak load in Denmark is around 6.000 MW potential. The TSO organisations wish to have a well functioning market including flexibility in the demand (price elasticity). Analysis of the potential for demand response exposes different options within a number of customer categories. The different ways may add up to around 600 MW.

125,000 houses are heated by direct electric heating in Denmark. In case 50,000 of these customers are offering demand response with an average demand of at least 4 kW/house on cold days, this gives a demand response potential of 200 MW.

Hourly metering and the potential of load control in peak hours give opportunity for new products from the supplier of electricity. Customer dynamics might reduce the risk of the supplier connected to periods with huge fluctuations in spot price.

Hourly remote reading gives new possibility in the work of the network companies.

The success in the pilot project forms the way for a future large scale testing of equipment, data flow and load reduction in close cooperation with suppliers and network companies.

Next generation of technology enables a much more flexible system having access to individual management of the single appliances and end-uses.

The cost/benefit for such a project seems promising.

The households with electric heating have shown to be very flexible, happy with the participation and they offer to continue with demand response.

### 3 Finnish Pilot: Effect of Web-based feedback on the electricity consumption and load curves.

#### 3.1 Description of the pilot

The Finnish pilot project was carried out by the Finnish Technical Research Centre VTT in cooperation with the real estate company VVO. VVO is the second largest owner of residential real estates in Finland after Helsinki city. Currently it owns some 40,000 homes. Most of the homes have been built using government-supported loans, therefore carrying income limits for tenants. In addition to VVO, project partners included the engineering office Suomen Talokeskus Oy.

The pilot involved 31 real estates in the city of Tampere, of which four were terraced houses and the rest blocks of flats. The purpose was to measure the real estates' electricity consumption more accurately than usual and give the measurements as feedback to the residents. The main objective was to study whether the consumption feedback would cause changes in consumption. This idea is depicted in Figure 9.

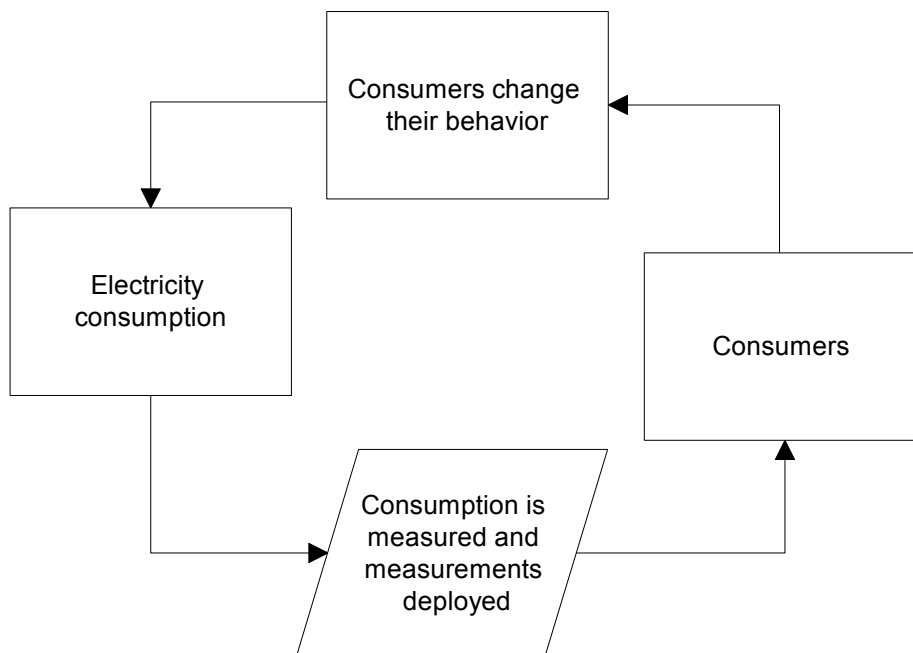

Figure 9. The feedback loop in electricity consumption measurement.

The main responsibility of monitoring electricity consumption among residents belonged to so-called *energy experts* who are voluntary laymen. Each of the 31 real estates had one energy expert. The experts are residents in the real estates and change from time to time. The experts can monitor and affect common real estate consumption (see below). Therefore

the target in this study was particularly the real estate electricity consumption.

The effect of feedback on consumption has been studied previously by Haakana and Sillanpää (1996) who studied household consumption in single-family houses. Comparative consumption data was sent to households by mail each month. The households recorded their own consumption themselves. No change could be seen in household electricity consumption.

The subject has also been studied in cooperation between Helsinki University Social Psychology department and Helsingin Energia (an electricity producer). According to Arvola (1993) consumption feedback did produce savings. Savings were not specific to certain types of apartments or families.

The Finnish Ministry of Trade and Industry (1994) states that households' energy efficiency could be affected by increasing their knowledge about their energy consumption volumes.

## 3.2 Achieved results and key figures

### 3.2.1 The *Kulunet* service

In each real estate one resident is chosen as energy expert who monitors energy consumption and gives advice to other residents. Traditionally energy experts have followed electricity consumption through paper reports which have been sent to them four times a year. The report contains graphs of monthly consumption of real estate electricity consumption and the corresponding values from previous years. It also contains graphs of water and heat consumption.

The engineering office Suomen Talokeskus was involved in measuring the electricity consumption. Suomen Talokeskus maintains the *Kulunet* website (<http://www.kulunet.com>), from which the consumption measurements can be accessed. The system has been partly built by Software Company Agentec Oy. The functioning of the system is now briefly described.

Real-time consumption measurement has been installed into the real estates. Four different quantities are measured: the *real estate consumption* (later abbreviated REC), *total consumption* (TC), reactive power consumption and consumption of those households who don't buy their electricity from VVO. Note that VVO also acts as an electricity seller. *Household consumption* can be calculated as the difference between the total consumption and real estate common consumption. Real estate electricity consumption refers to consumption which is paid by VVO, in contrast to household consumption, which is directly paid by the residents themselves. Typical constituents in real estate consumption are lighting, air conditioning, sauna heating and in the winter car heating.

The consumption meters produce 250 pulses for each kilowatt of electrical energy (or reactive energy). After 250 pulses the MT30-type counter registers one kilowatt-hour of energy consumed and adds it into that hour's consumption. Consequently, the measurement precision for power consumption is one kilowatt. In mathematical terms, if  $a(t)$  is the number of pulses for hour  $t$ ,

$$P(t) = DIV(a(t) + b(t-1), 250)$$

$$b(t) = a(t) + b(t-1) - P(t) \cdot 250$$

where  $DIV(x,y)$  means the integer division of  $x$  by  $y$ . This arrangement causes that when the residual pulses  $b(t)$  gather, occasionally the meter reading bounces up to one kilowatt higher than the actual consumption. An improvement to be able to read the consumption more accurately has been suggested.

The consumption data is stored in the meter and read daily into Talokeskus through modem.

The Kulunet service requires a username and password and varying user rights can be defined to different users. An example from the Kulunet interface can be seen in Figure 10.

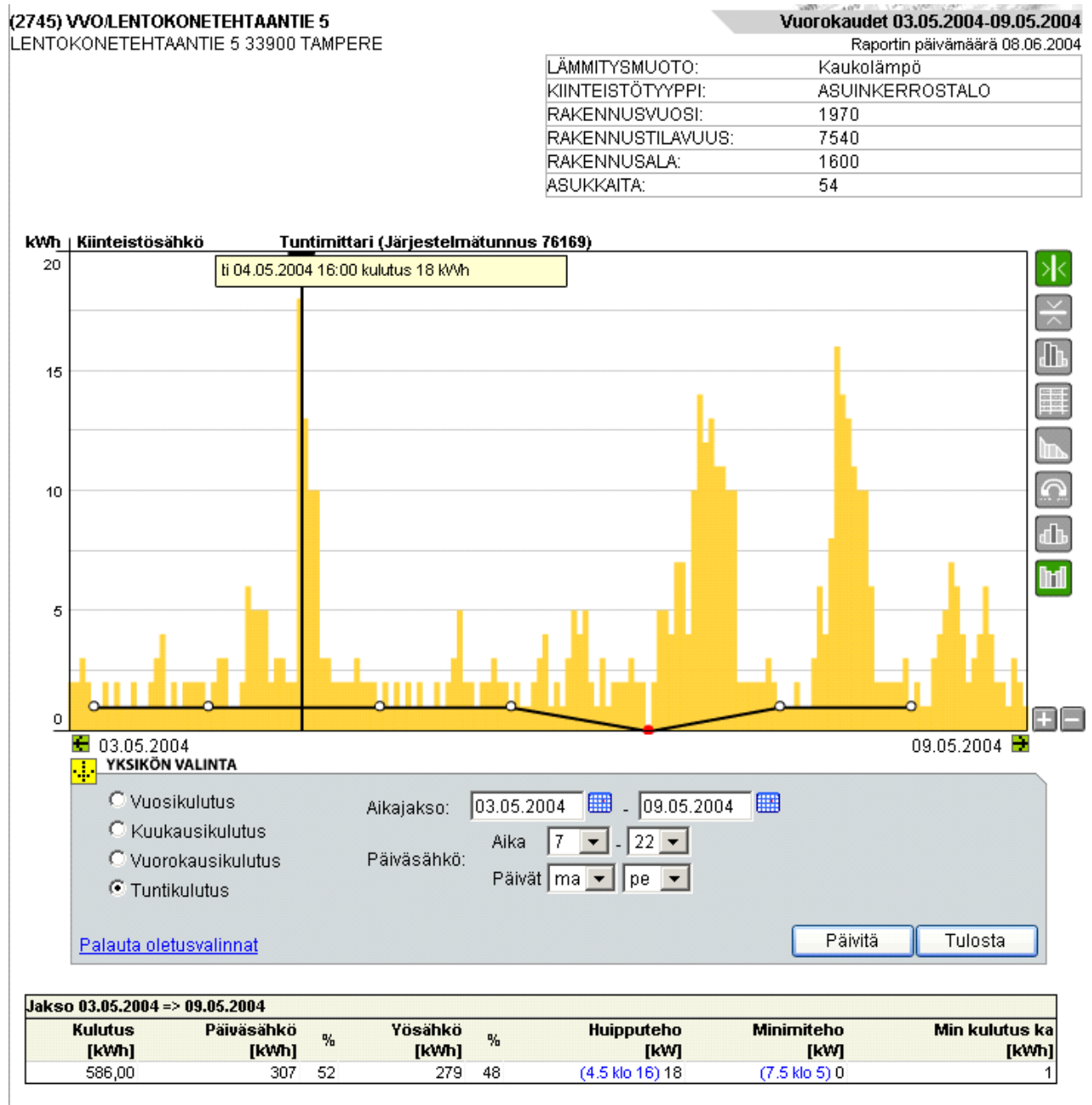

Figure 10. A view from the Kulunet website. Here a period of hourly real estate consumption has been extracted. The solid horizontal line at 1 kW marks the daily minimum consumption.

The Kulunet service has been available to energy experts since late 2000. The energy experts in the pilot real estates have used it since October 2001, although not too actively (see below). The service includes a log where all visits are registered. A user has to log in again if he/she has been idle for more than 15 minutes. The re-logout is registered in the log as a new visit. If logged visits are used as a measure of activity of use, this was not seen as a skewing feature.

The log has been kept since late year 2000 until the summer 2003. The data is available until August 8<sup>th</sup> 2003. Unfortunately after this, due to changes in the system, the log has been accidentally turned off and also all remaining data after August 8<sup>th</sup> has been destroyed. The log has been turned on again on 15<sup>th</sup> February 2004.

### 3.2.2 Available data

Of the 31 pilot real estates monthly real estate electricity consumptions are available since at least 2000, often since 1990, depending on the real estate. The consumptions were thus extracted from the database since January 1994 and the missing values were generated by copying the values of corresponding months from later years. Missing data generation had to be done with three real estates (real estates 2, 18 and 23), for 34, 36 and 69 months since January 1994. The full series was 125 months.

From Figure 11 one can see the standard deviations calculated from the monthly consumptions of real estate electricity, where the consumptions were first divided by their mean value. Normalizing is necessary to put smaller and bigger real estates on the same line in the comparison. The y-axis in the picture is unitless. For example number 0.3 would mean the standard deviation is 30 % of the mean value. The consumption variation seems to be somewhat smaller than average in point blocks. Also, it is evident that the variation in terraced houses is much greater than in all the blocks of flats. Notice that in this analysis the data has not been detrended, which causes that trends increase the calculated variation. The detrended picture would be almost the same.

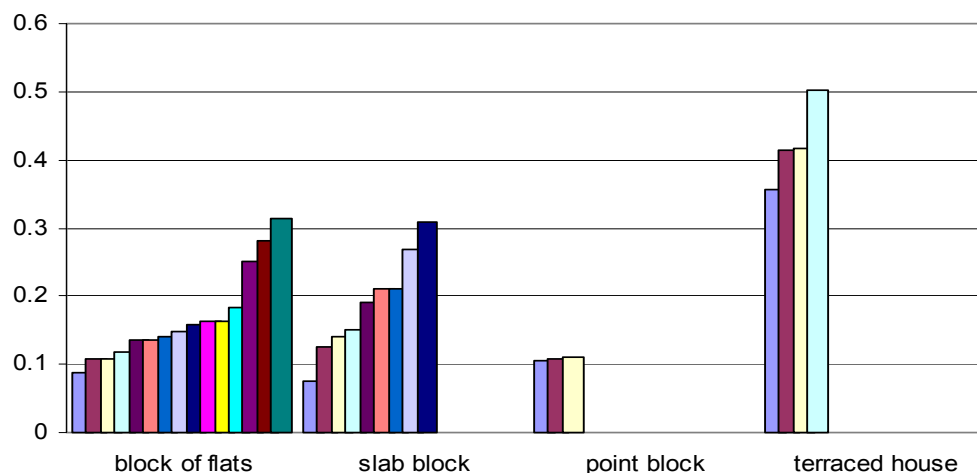

Figure 11. Standard deviations of normalized monthly consumptions of real estate electricity in the 31 real estates involved in the study.

Hourly measurement data was available from different start-point for different real-estates. For most real-estates it was available since 28<sup>th</sup> November 2000, for some others since July 2001 (real estates 3, 18, 22 and 29) and for one real estate (real estate 11) since 5<sup>th</sup> March 2002. Hour data was not available to real estate 16 for December 2003 and January 2004 because of meter problems.

Heating index numbers (see below) were available particularly for Tampere up to January 2004 and were measured by Suomen Talokeskus.

### 3.2.3 Consumption dependencies

The net dwelling area turned out to be the best explanatory variable of real estate electricity consumption or different real estates. The number of apartments was also a good explanatory variable and is naturally highly correlated with the former (see Figure 12). A third variable which was well correlated with the average consumption was building volume. The coefficients of determination ( $R^2$ ) values were 0.846, 0.824 and 0.651 respectively. It was difficult to perform multiple regression on such a small dataset, especially since most explanatory variables are correlated with each other.

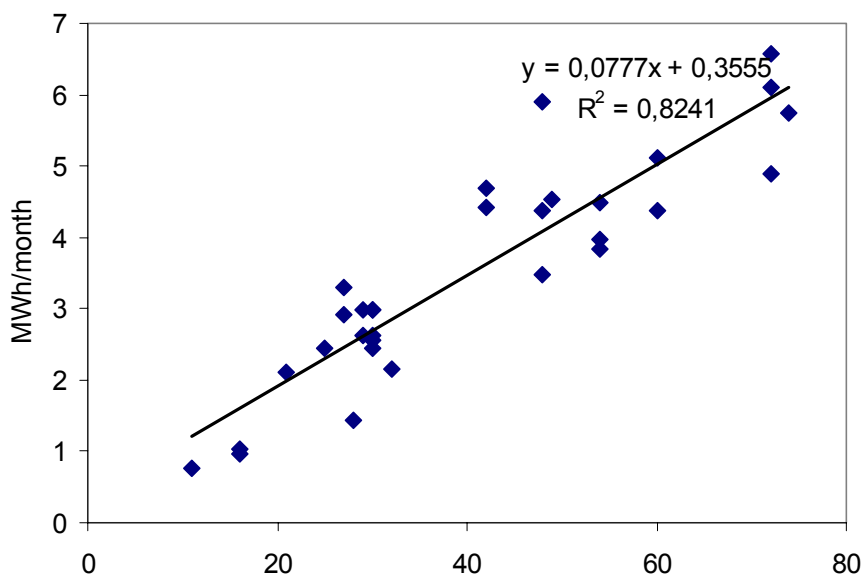

Figure 12. Average monthly consumption of real estate electricity plotted against the number of apartments. The standard error in the regression was 660 kWh/month.

There is no up-to-date data of the numbers of residents in each real estate. There are some figures but they are not accurate. When linear regression was performed by using the number of residents as explanatory variable for real estate electricity consumption, the coefficient of determination was  $R^2 = 0.78$ .

Facility level (abundance of saunas, electrified parking slots, staircase and outdoor lighting,

drying rooms etc.) should have a large effect on consumption. It turns out however, that their effect is almost completely hidden underneath the size of the apartment as well as noise.

The number of electrically heated parking slots explains REC poorly. This is true also if we only consider the REC for winter months (December–March). If a regression analysis is performed for the difference of winter months REC and its average against the number of electrically heated parking slots, the fit is much better, but still poor. There is, however, a dependency between the increase of monthly consumption with heating index number<sup>2</sup> and the number of electrically heated parking slots as can be seen from Figure 13. In other words, consumption of the real estates with plenty of parking slots depends more strongly on temperature. The slope of the trendline is 64 Wh/month/degree-day, which is well in the correct range. However, in this analysis it was not concluded that the consumption increase would actually be because of low temperature. Later analysis suggests that the seasonal variation of consumption inside the year just coincides with the heating index number. The actual reason for seasonal variation may for example be more lighting in winter.

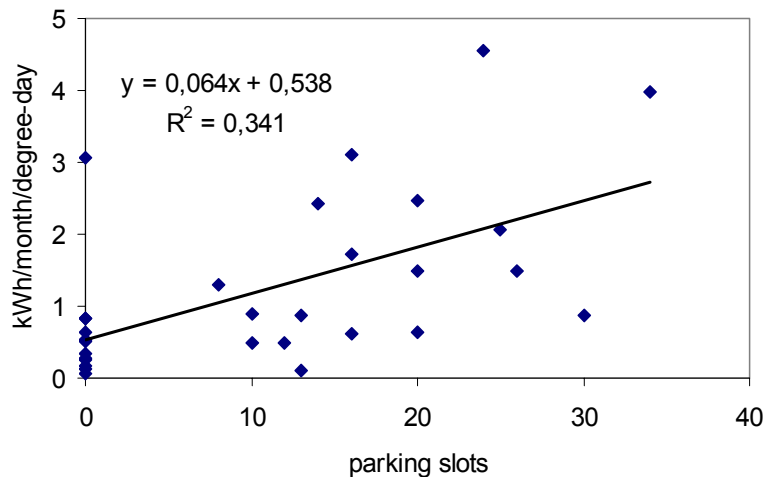

Figure 13. Increase of monthly real estate electricity consumption with heating index number (obtained from data with regression) and the number of heated parking slots.

There is no visible connection between REC and cold storage rooms of the real estates. Only the information whether cold storage room(s) existed or not, was available. The number or drying rooms was a somewhat better explanatory variable but still its connection to REC was weak.

The number of saunas alone has an R-squared value of 0.7 against the average consumption. If dual-variable regression is carried out where the numbers of saunas and apartments are both explanatory variables (Table 2), the number of saunas is not a great explanatory variable. An F-test would point out that there is a 17 % probability that the additional contribution to the coefficient of determination (R-squared) is purely coincidental.

<sup>2</sup> Heating index number is defined as the sum  $\sum_d (17^\circ\text{C} - T_{amb}(d))$ ,  $d \in \{[1,365] | T_{amb}(d) < 12^\circ\text{C}\}$ , where  $T_{amb}$  is the average daily outdoor temperature.

Table 2. Dual-variable regression, saunas and apartments versus monthly REC.

MWh	Coefficient	Standard Error
Intercept	0.547	0.320
Saunas	0.302	0.212
Apts	0.061	0.013

In practise, however, saunas consume a large part of the real estate electricity. Saunas may be used more actively in some buildings than in others. Therefore the weekly sauna programmes were obtained for 10 of the pilot real estates and the total number of stove-on hours calculated. In Figure 14 this number has been plotted against the mean real estate electricity power in 2003. It can be seen that the fit is not any better than when using the number of saunas to explain the average consumption in a longer period ( $R^2=0.70$ ,  $N=31$ ) or in 2003 ( $R^2=0.69$ ,  $N=10$ ). Why the more accurate explanatory variable produces a worse fit remains a mystery at the moment.

Using the hourly consumption data it is possible to calculate the average consumption of real estate electricity on Friday and Saturday from 6 pm to 9 pm when saunas are usually on. The number of saunas as explanatory variable for this figure gives a coefficient of determination 0.63, a low value. Moreover, when the effect of real estate size was removed, the number dropped drastically. We conclude that based on the regression analysis the number of saunas has a weak linear connection to average REC, whether it was averaged over the whole time series or just intensive sauna heating periods taken.

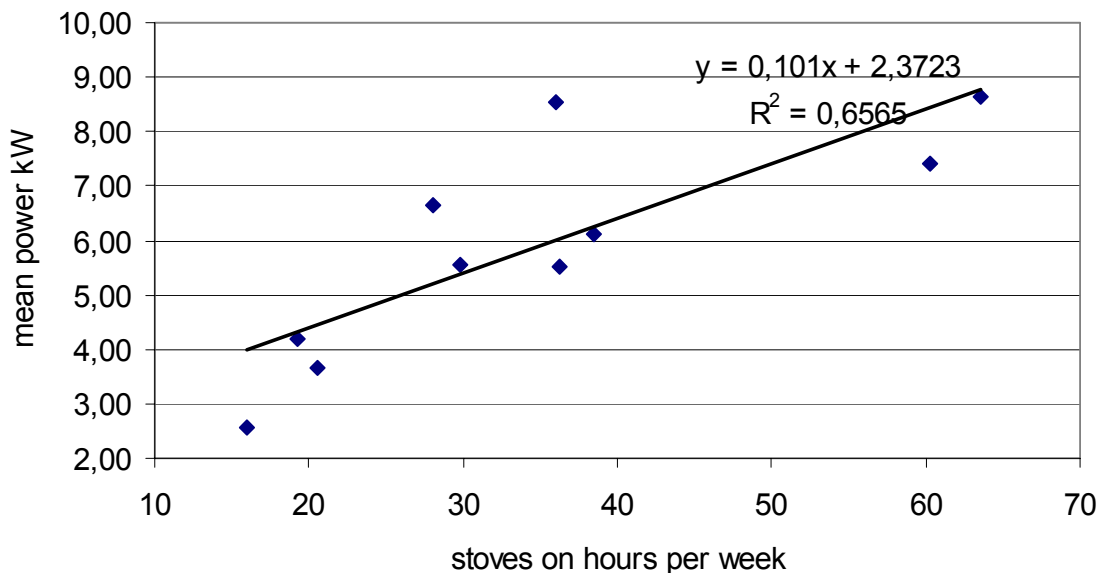

Figure 14. Mean real estate electricity power in 2003 plotted against the total sauna stove-on hours per week. The effect of real estate size has not been subtracted.

Temperature dependency of the consumption was studied by first removing other effects from the monthly REC series. It was supposed that three factors affect the monthly consumption:

1. Time, which may be present in a linear trend in the data
2. Seasonal variation, i.e., each month has its own particular average consumption
3. Temperature, which alters consumption when it deviates from the month's average

The monthly REC series from 1993 to 2002 were first detrended; there was no significant trend in the heating index numbers. Seasonal variation was removed by calculating an average consumption and average heating index number for each month of the year. These were subtracted from the original series. The consumption deviation of the month's average was then regressed against the heating index deviation from the month's average for each real estate. The result was that for most real estates there was no dependency between the seasonally adjusted heating index number and seasonally adjusted consumption.

Figure 15 shows the coefficients of determination from a linear regression between the variables. A colder-than-average winter may well go together with a lower-than-average consumption. In real estates 11 there is a clear temperature dependency and in real estate 20 there is a somewhat clear temperature dependency. For real estate 11 a 100 degree-day increase in the monthly heating index number produced on the average 0.67 MWh increase in REC consumption. In other words, a 10 % rise in consumption in winter would require a 13 % rise in heating index. Notice, however, that the analysis was applied to all months and not just winter months.

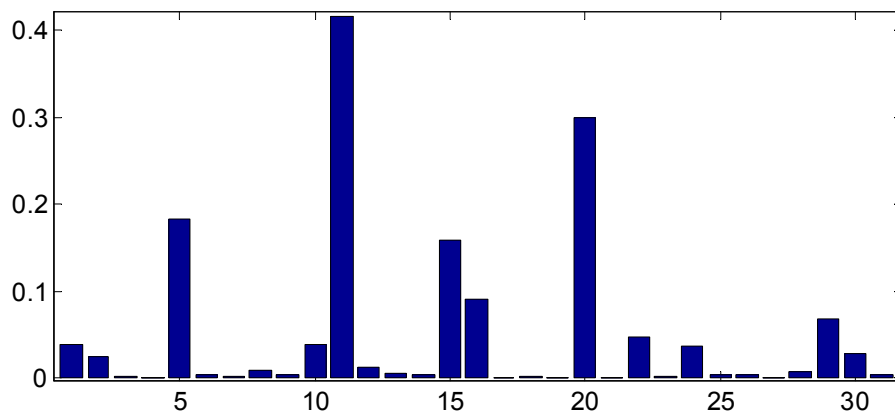

Figure 15. *R-squared values from linear regression between seasonally corrected and detrended REC monthly values and seasonally corrected heating index numbers. The abscissa labels refer to different real estates*

The specific consumption (energy per building volume) was calculated. The average was 380 Wh/month/m<sup>3</sup>. There are no significant differences in specific consumption between different building types (Figure 16). Also there are no significant differences in specific consumption between different city districts. There is neither a clear trend with respect to the construction year.

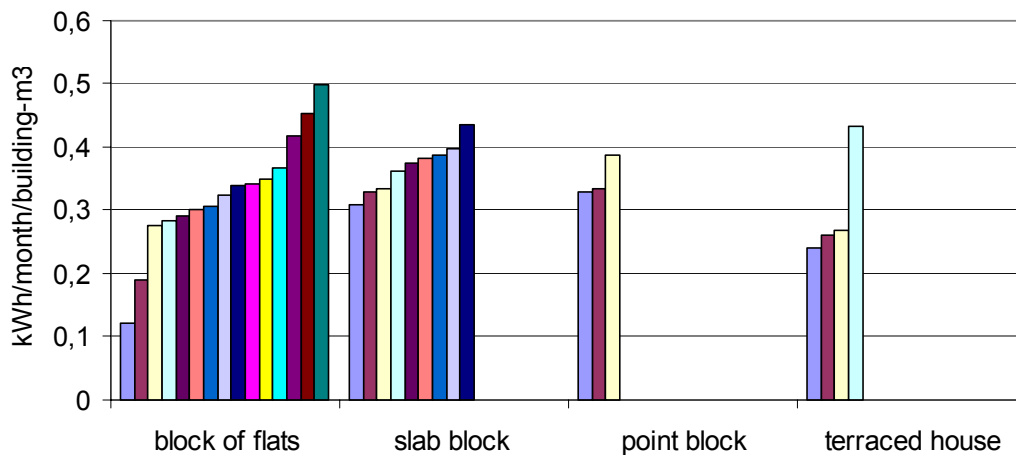

Figure 16. The specific consumption (power / building volume) in different building types in 1994–2002.

### 3.2.4 Grouping of the real estates

Consumption feedback could have a different effect on different kinds of real estates. When the effect can be stated as a numerical value (such as decrease in consumption) its relationship to the real estate attributes (such as size) can be analyzed in normal statistical techniques. When the effect cannot be easily stated as a number, it is a good idea to group the real estates and study the effect separately for each group. There are many ways to group the real estates. The grouping can be based on attributes such as size, location or facility level. Another way is to group based on consumption behaviour.

Of course, since expert activity has remained low, as explained further below, the grouping analysis is not so grateful as it could be. The main purpose of grouping is then to gain insight on the nature of consumption in the pilot real estates.

The measurement data was averaged to produce a simpler description of the daily and annual consumption behaviour. This is desirable since there is a lot of redundancy in the data. The hourly consumption behaviour was calculated for each weekday in each month. That is to say, for each month 24x7 values, representing one full week, were calculated per real estate. Therefore, if two years one data were available, about 8 values (two years, four weeks per month) of the original data were averaged in the final curve.

In principle, putting these curves into groups is easy. One just has to have a measure for how different two curves are. This distance between two load curves or *norm*, as it is called mathematically, can be for example the second, or *Euclidean* norm

$$d(v_1, v_2) = \sqrt{\sum (v_1(i) - v_2(i))^2},$$

where just root-sum-square of the differences between individual power values is calculated. While this is the most obvious choice, it is not at all clear that it produces the best results. For example if there's a peak in one curve at 7 o'clock and another similar curve has the peak at

9 o'clock, the Euclidean norm would indicate that there is a big difference in these curves, although the difference is just a small shift in the time of the peak. Another possibility is the *ABS norm* which is just the sum of absolute values of differences between vector elements. Peaks don't affect this norm quite as much as the Euclidean norm. However, in practice the difference in results between applying ABS or Euclidean norm was very small.

The so-called K-means algorithm (Therrien 1989) is one of the many vector grouping algorithms available today. It is very simple and quite effective. The algorithm consists basically of following steps:

- 1) Assign some initial grouping
- 2) Calculate the mean vectors of each group, and the distances from each vector to each mean vector
- 3) Assign each vector to the group whose mean vector is closest to it
- 4) If grouping was changed, go to step 2, otherwise quit.

There is also the case when some group becomes empty when vectors are shifted to other groups. In this case the procedure was to assign the vector which is farthest from all groups to the empty group. Also it was stipulated that this vector must not be alone in its current group.

Of course, one can also group the vectors manually by just looking at the matrix of distances between different consumption curves. Both manual and K-means grouping were used and they produced similar results.

As a result three groups emerged. Group 1 consisted mainly of older real estates with few parking slots. Group 2 was newer real estates with more parking slots. These real estates were all blocks of flats. Group 3 contained all terraced houses, four in all. Parking slots affected the result because they draw electricity in the morning, a distinct feature. Why newer real estates ended up mainly in group 2 is unclear. There is no correlation between the age of buildings and number of parking slots.

Table 3. *Groups obtained from K-means grouping analysis*

Group	real estates
1	4–10, 12–14, 21–22, 26–28 and 30–31
2	1–3, 18–20, 23 and 29
3	15–17, 24

The curves in different groups differed from curves in other groups but resembled curves in the same group in both visual and auditory inspection. In auditory inspection the curves were played as sounds at different frequencies. Figure 17 shows as an example one week from the averaged REC curve of the terraced houses. The similarity is not striking in this group but in group 1 it is better.

Of course, since sauna consumption peaks are so prominent, they have a large effect on the vector distances. As a result, use of sauna affects the grouping very much. This reduces the usefulness of the grouping.

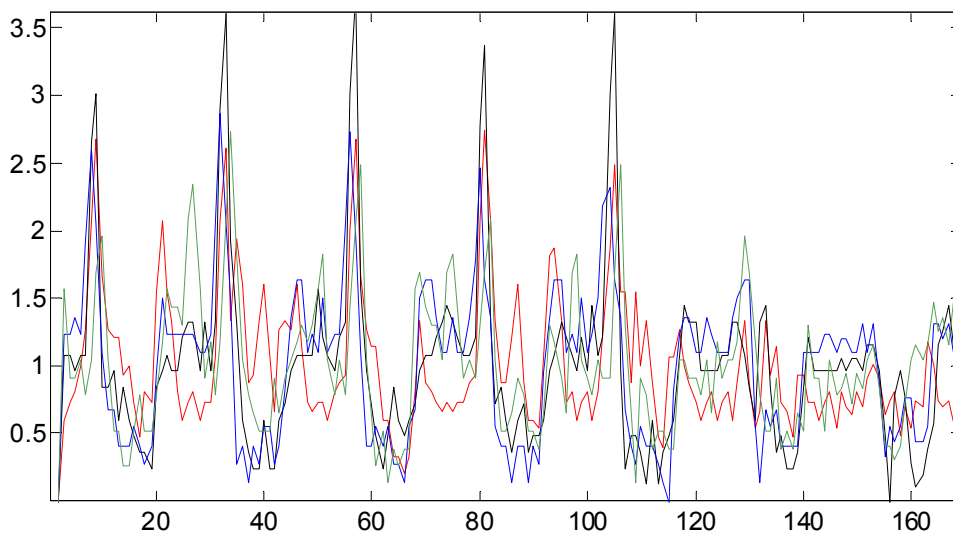

Figure 17. Normalized REC of real estates 15, 16, 17 and 24 (terraced houses) averaged for one week in February '04.

### 3.2.5 Availability and utilization of feedback

The main objective was to study the effect of feedback information on consumption. The *level of feedback information* could be defined in two ways:

- 1) use: how many people are taking advantage of the feedback and how actively, or
- 2) availability: what is the quantity of feedback available and how many people know about it.

If the first, more stringent, definition is used, the level of feedback can be directly studied from the Kulunet user log. As mentioned above, the log was accidentally turned off so that the time period from 8<sup>th</sup> August to about 15<sup>th</sup> February is not available. This would have been a very important time period for the study. The log for Spring 2004 can be used in the study but its value is less because it usually takes some time before experts may notice any anomalies in the consumption curves, report it forward, and action is taken. During the spring 2004 there was one log-on from real estate 13 and several log-ons from the new usernames which were created for everyone in February 2004.

As for the second definition, Kulunet has been available to experts since late 2000. Hourly consumption has been available since September 2003. As mentioned, on June 6<sup>th</sup> 2003 an information letter about Kulunet was sent to the pilot real estate experts. Later the experts were sent ready-created usernames and passwords. This was supposed to happen in August 2003 but because of ongoing update work of the service, they were not sent until February 15<sup>th</sup> 2004.

Also the experts were advised that if they saw it appropriate, they could publish the username and password on the noticeboard of their building, allowing every resident to monitor the consumption data. Figure 18 summarizes the availability factors of feedback information mentioned above.

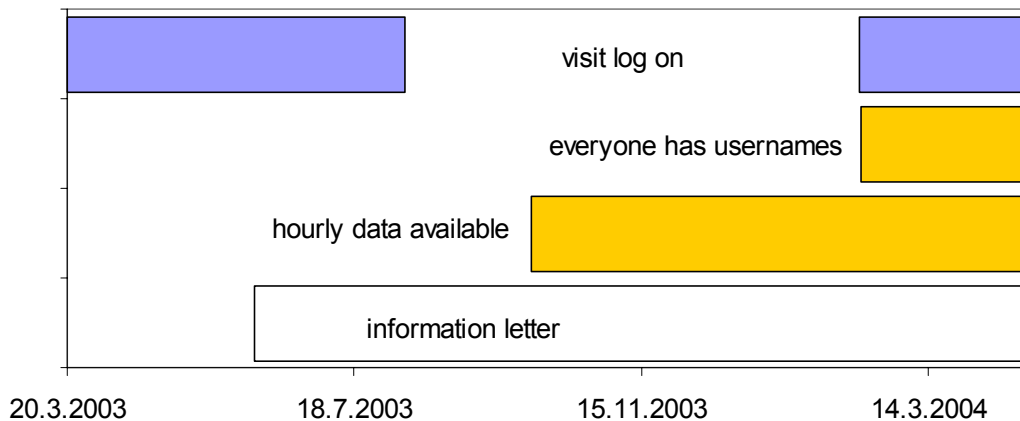

Figure 18. Graph of the availability factors of consumption information.

In our opinion the information letter had some effect on the availability (as defined above) of feedback information but no effect on the use until 8<sup>th</sup> August. Note however, that the information letter and a combined questionnaire could have affected the interest in following the paper reports. The steps taken in February 2004 had a large effect on availability and some effect on use.

Figure 19 shows the frequency of expert log-ons in Kulunet. These numbers include *all* VVO experts who have ever used Kulunet. According to the 8.8.2003 log there are 98 of them. From the figure it is easy to see that the number of monthly visits has increased about two-fold during the period. This is easily understandable since several new experts have got their user names during the period.

Again from the log it is visible that some experts have been more active than others. From Figure 20 it can be seen that 25 % of the experts have been responsible for 75 % of log-ons. The figure has been constructed so that the experts have been first sorted according to their total number of log-ons and each expert has been given an ordinal number, 98<sup>th</sup> expert being the one with the most log-ons. The y-axis number is the total sum of log-ons between the first expert and n<sup>th</sup> expert. The median of the number of log-ons per expert, which is the slope of the curve in the middle, is three. We can conclude that, leaving aside a few most active experts, the experts have not been too active in using the Kulunet service.

EFFLOCOM: Energy Efficiency and load Curve Impact of Commercial Development in Competitive markets

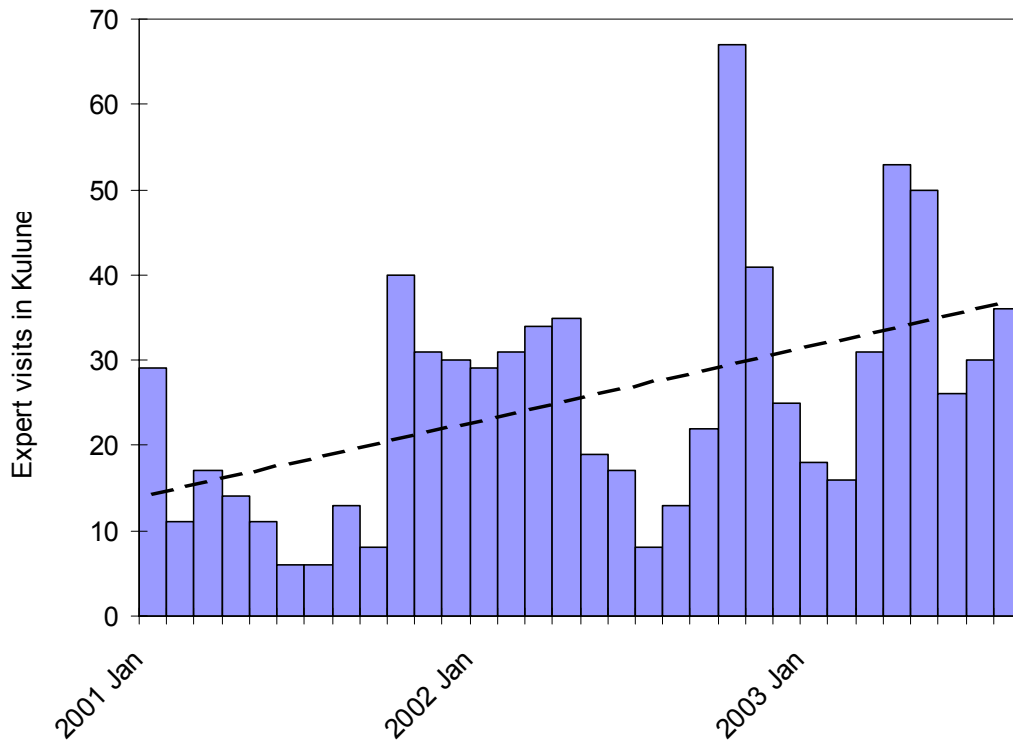

Figure 19. Expert visits in Kulunet for all VVO experts for 30-day periods beginning in January 2001.

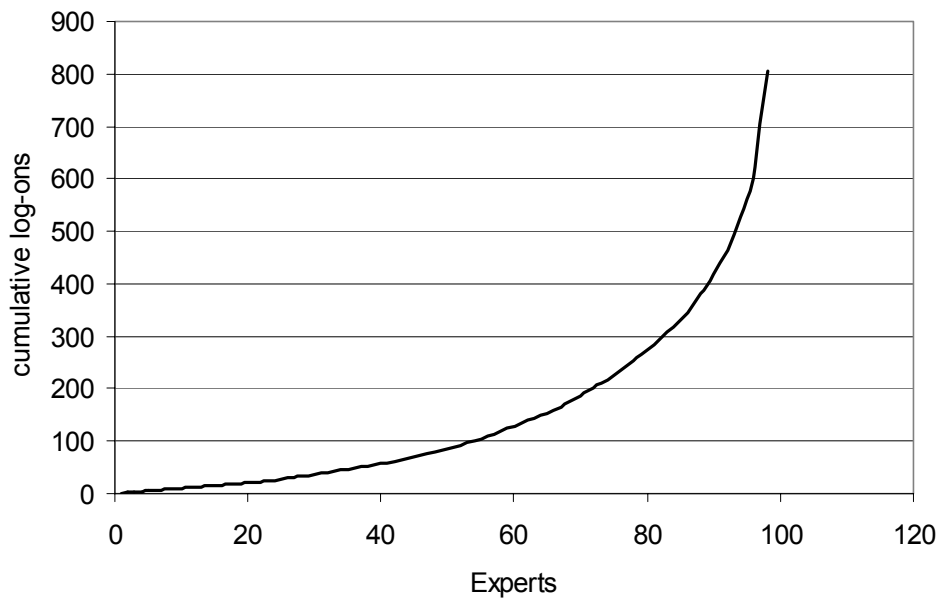

Figure 20. The cumulative number of log-ons versus number of experts when the experts are sorted according to their number of log-ons.

In the above were presented some statistics involving all the VVO energy experts. In the 31 pilot real estates in Tampere only three experts had ever used Kulunet as of 8<sup>th</sup> August 2003. Of these one had only visited the site twice, as can be seen from Figure 21. Moreover, according to the log from spring '04 (February 16<sup>th</sup> – April 30<sup>th</sup> 2004) the expert from real estate 13 visited the site once. In addition, there were 12 log-on's from the newly created (Feb 15<sup>th</sup>) usernames, which were from real estate 6 (7 log-on's), real estate 4 (2 log-on's) and real estate 24 (2 log-on's).

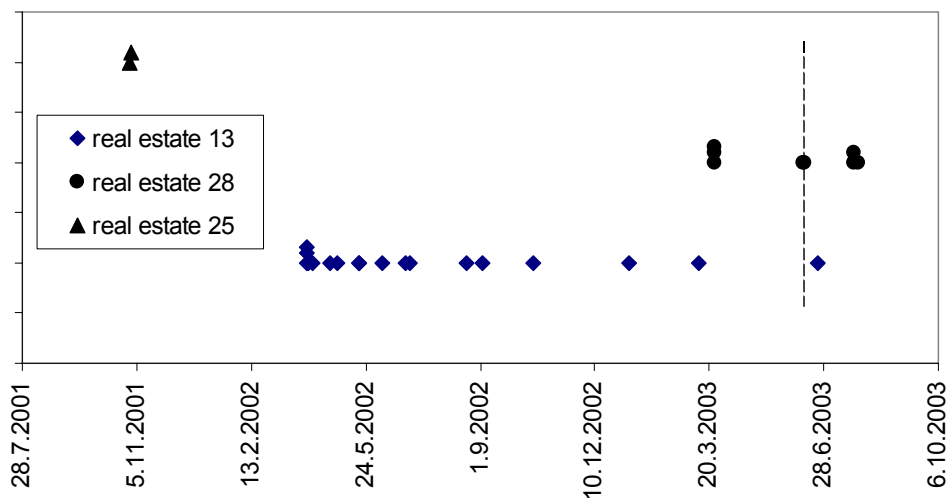

Figure 21. Pilot real estates expert visits in Kulunet. The vertical line shows the sending time of the advertisement letter. The different data series refer to different real estates (real estate numbers in the legend box).

On 6<sup>th</sup> June 2003 an advertisement letter was sent to the energy experts in the pilot real estates. The letter included instructions on how to get a username for Kulunet, as well as explained the benefits of web-based consumption monitoring as opposed to traditional paper consumption reports. Mentioned was for example the possibility of comparing consumption to that of other real estates and faster update cycle of the data, as well as easy access to historical data. It was promised that the monthly data was available by the 15<sup>th</sup> of the next month. Hourly data was not available to experts at that time. Hourly data is updated into the system once a week.

At the same time a questionnaire was sent to the experts. It asked questions about access level to a computer and the Internet, activity of Internet use, and the channel through which the experts follow energy consumption. The response rate was 30 %, a low value. Both the active experts who had used Kulunet answered the questionnaire. Both the active experts had an Internet connection at their home. Of those who answered and had the Internet at home (5 experts), the active experts' use of Internet was not particularly intensive. Those experts who didn't use Kulunet, all followed the paper reports.

A new questionnaire has been sent to the experts on May 25<sup>th</sup> 2004. In addition to the previous questions, the experts were asked the main reasons that discouraged them from using Kulunet more actively. They were also asked whether consumption feedback had

helped them to find some abnormalities in electricity consumption. Results from this poll are shown below.

The previous figures of log-on's into Kulunet website mostly refer to viewing of monthly consumption data. According to interviews none of the three most active experts (real estates 6, 13 and 25) had viewed hourly data. It is possible that real estates 4 and 24 have viewed hourly data but together they are responsible for just four log-on's.

### 3.2.6 Consumption changes since summer 2003

The level of feedback information can be considered as the input to a system where the response is a change in consumption. First we should remember that there are natural changes in consumption in the course of time. The real estate consumption has grown on the average some 1.2 percent a year since the beginning of 1994. Figure 22 presents the average annual change (%) of REC for the pilot real estates. However, it is questionable whether this growth trend can be used in predicting the future consumption. A test was performed where the average consumption of years 1997 to 2000 were each forecasted *ex post* based on the average consumption of the previous year, as well as the average growth of consumption until the beginning of that year from a period of four years. The average growth of consumption was estimated with linear regression.

The result was that the use of growth information lowered the forecast accuracy. The root-mean-square values of average monthly consumption forecast errors were 0.36 MWh with growth information and 0.31 MWh based on the average consumption of the previous year only. This is probably a result of a highly variable consumption from year to year. Naturally, if the parameter (consumption growth) estimation period is longer, one may expect better results. But then again, the growth may not last for ever, which would make the growth model invalid.

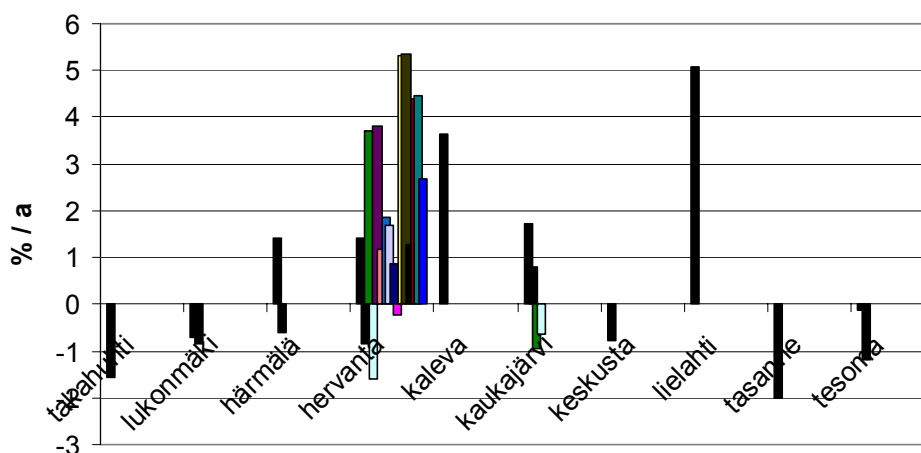

Figure 22. The average annual change of real estate electricity consumption in the pilot real estates between 1994 and 2002. The names on the abscissa are city districts.

When we compare the hourly values that may have been affected by better feedback information, we may use the linear model

$$\bar{P}(h, m, y) = \alpha \bar{P}(h, m, y - n \dots y - 1) + \beta ,$$

where  $\bar{P}(h, m, y)$  is the averaged consumption for year  $y$ , month  $m$  and hour of week  $h$  ( $h=1\dots 168$ ).  $\bar{P}(h, m, y - n \dots y - 1)$  again is the same for years  $y-n \dots y-1$ . As explained above, we don't compare the individual hourly measurements but first calculate the average (inside one month) of the values which pertain to the same hour of week.

The left-side dependent variable was chosen to be the averaged consumption (averaged for each hour of week) for months July 2003 – January 2004. These seven months were chosen so because the information letter was sent in June 2003. The explanatory variable was the averaged consumption (averaged for each hour of week) for the corresponding months in previous years, as many years as are available for each real estate. Thus there were  $7 \times 168 = 1176$  observations from both variables. In the model  $\beta$  refers to a constant increase in power throughout every time point, whereas  $\alpha$  refers to an increase proportional to previous consumption.

Figure 23 shows the  $R^2$ -values from the model. In general a low  $R^2$ -value shows that there has been a change in the shape of the consumption curve. An exception is real estate 23 but this is because of exceptionally high consumption in November 2003. The reason for this is not known. The real estates 6, 13 and 25, which had the active experts, have average or higher than average  $R^2$ -values. Note the terraced houses 15–17 and 24 which had low  $R^2$ -values. This is because measurement errors (up to 1 kW) are large compared to the average power. Real estate 9 had a low value because a new high-power appliance was installed in the comparison period. There was also an increase in consumption for real estate 2 in the comparison period but the reason for this is known.

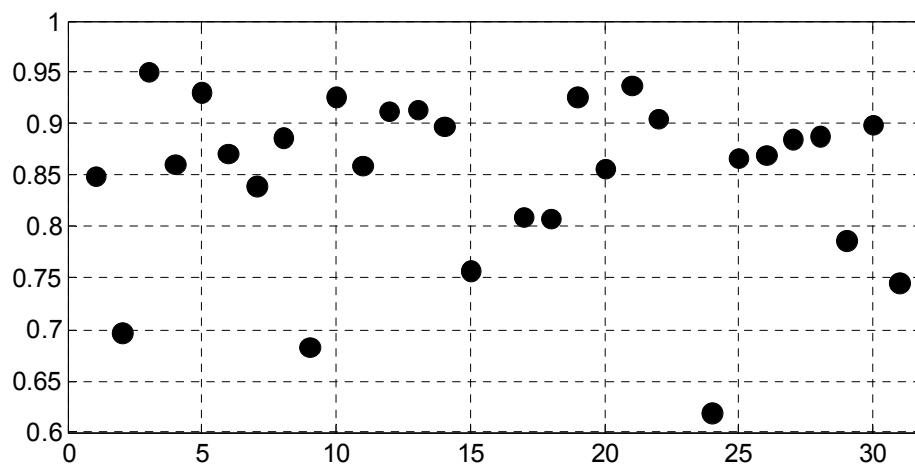
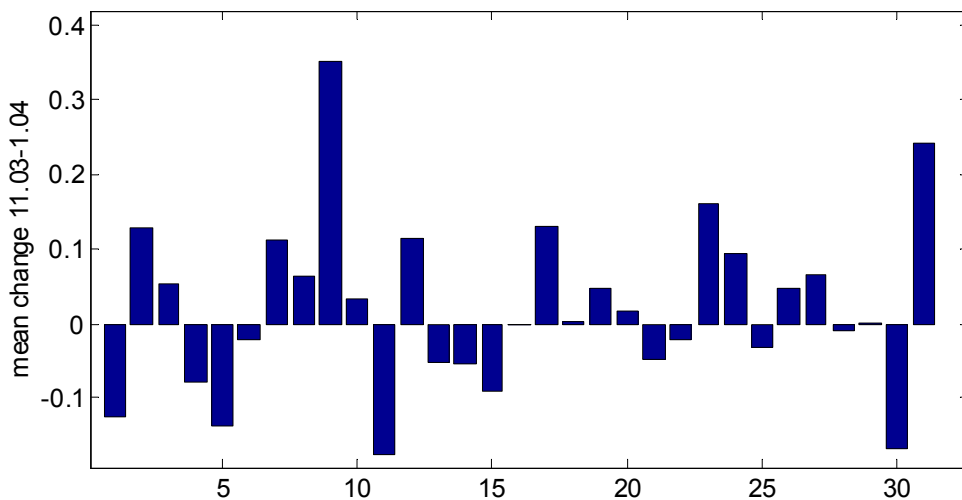

Figure 23.  $R^2$ -values from model where the consumption in July 2003 – January 2004 was explained by the corresponding period's consumption in previous years. For real estate 23 the value was 0.1. Notice that the model could not be evaluated for real estate 16 because of

*metering problems since November '03. X-axis is the real estate number.*

The risen level of minimum power in real estate 9 arises from a GSM base station whose consumption is included in real estate electricity. The station was installed in December 2002. In real estate 31 consumption has grown several kilowatts starting in November '03. In real estate 11 consumption was decreased a few kilowatts starting in October '03 and this is clearly visible in Figure 24. It is possible that this is (certainly partly) due to temperature dependency.



*Figure 24. Relative mean change of REC between Nov 2003 – Jan 2004 and the same months in previous years. X-axis is the real estate number. For example in real estate 11 real estate electricity consumption went down by 17 %.*

These changes, apart from what was mentioned, could not be accounted for. Even VVO has limited resources to investigate (renovations, new appliances, malfunctions, etc.) what has happened in each real estate.

Notice the beginning of winter '03–'04 which was warmer than normal (Figure 25). This has probably affected car heating. However, on the average one parking slot decreased the average consumption compared to past values in all real estates in Nov–Dec just 20 W. We may conclude that parking slots have caused some decrease in consumption but the effect is weak.

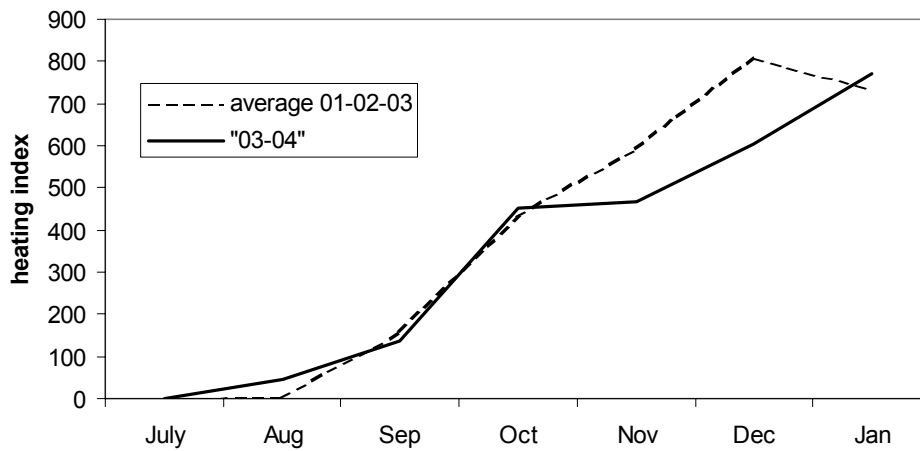

Figure 25. Heating index numbers for the estimation period (solid line July '03 – January '04). November and December were warmer than normal in '03.

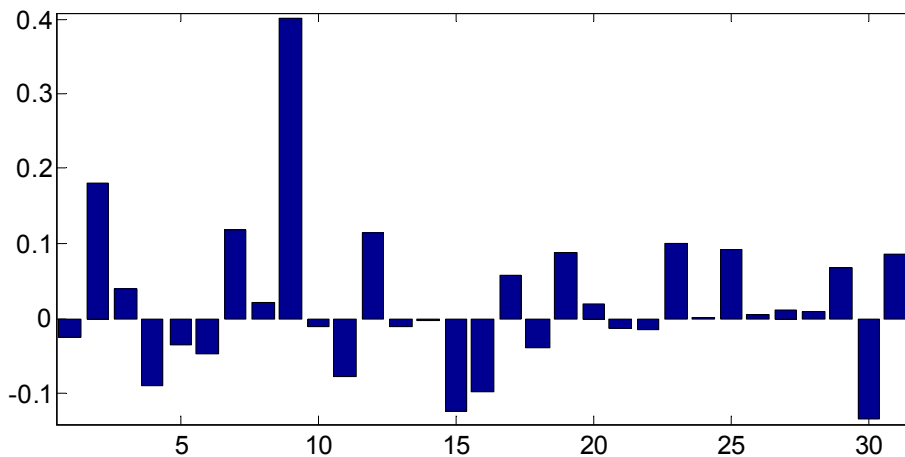

Figure 26. Relative mean change of REC between February – April 2004 and the same months in previous years. X-axis is the real estate number. For example in real estate 11 real estate electricity consumption went down by 8 %.

In Figure 26 the relative consumption changes in different real estates are shown. Spring '04 is compared to previous years (at most three years, depending on real estate). Trends have not been subtracted. In this figure, the decrease in real estate 30 is still present but the decrease in real estate 11 is much more modest.

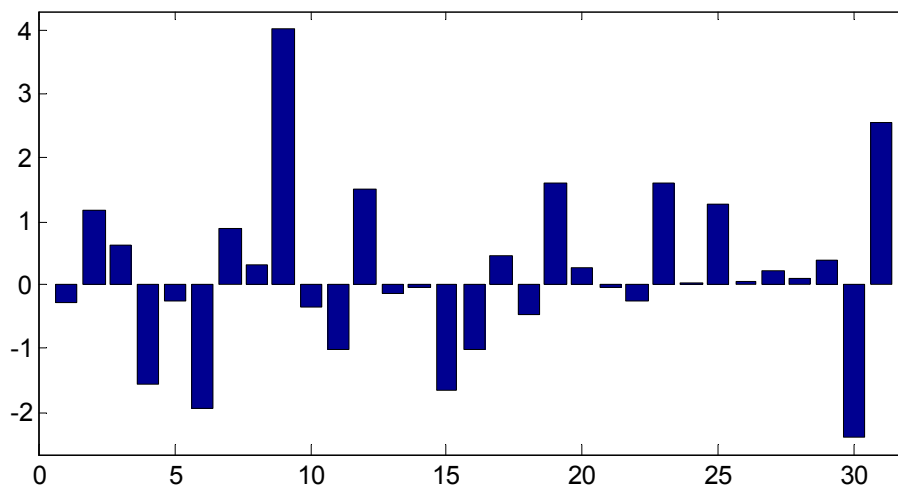

Figure 27. Mean change of REC between February – April 2004 and the same months in previous years (2001–2003 if available), relative to the standard deviation of the average consumption in February – April in different years from period 1994–2002. X-axis is the real estate number. For example in real estate 30 there was a statistically significant consumption decrease.

In Figure 27 the mean change, presented in Figure 26, has been related to the relative standard deviation. For example real estate 30 experienced a decrease which is about 2.3 times the standard deviation of detrended consumption in February – April in different years in period 1994–2002. On the other hand, real estate 31 experienced a significant increase. As explained previously, these changes cannot be accounted. Notice, however, that there is a 80 % probability that at least one real estate of 31 experiences a purely coincidental change that is at least 2 times the standard deviation. Also there's a 50 % chance that at least two real estate experience a change of this magnitude from pure coincidence.

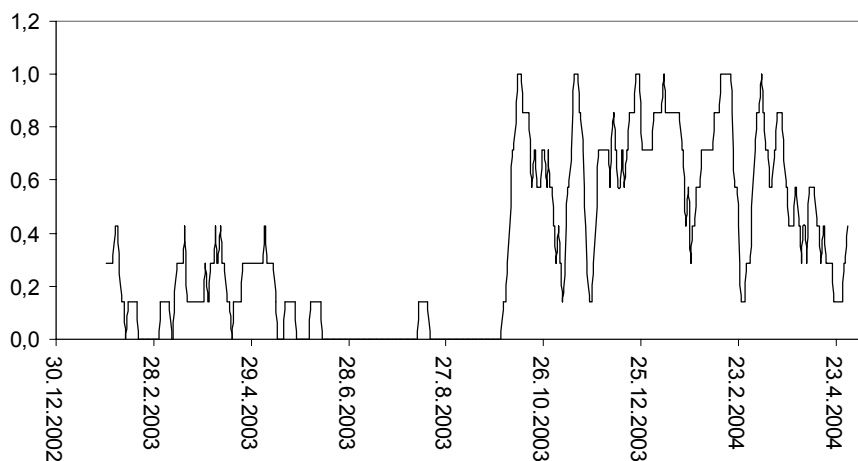

Figure 28. Daily minimum REC of real estate 7 (kW), seven-day moving average.

Daily minimum consumptions were calculated for all real estates since beginning of 2003. No

significant changes could be seen in most real estates. One exception is real estate 7 for which a clear rise in October '03 can be seen. This is plotted in Figure 28.

If we look at the total REC consumption of all the real estates, this was 457 MWh in February–May 2004. There's some 1,6 % increase relative to the average of the same months in 2000–2002 and 2,5 % increase relative to the average of the same months in 1999–2002. This implies somewhat lower growth than the 1,6 % annual growth in 1994–2002. This is shown in Figure 29.

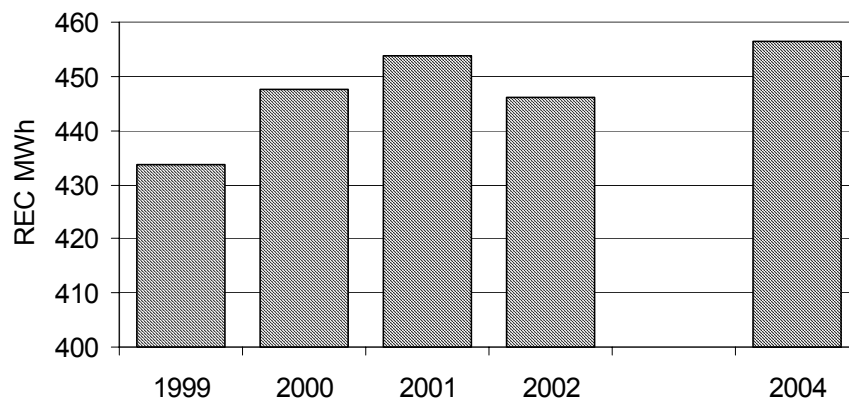

Figure 29. Total REC consumption of the pilot real estates in February–May of different years.

### 3.2.7 Real estates which had active experts

According to Kulunet log real estate 13 was the most active in following consumption feedback. From regression analyses we notice that the R-squared values for this real estate were high. When REC in November 2003 – January 2004 was explained with REC values from previous years, R-squared was 0.92. For the period February – April 2004 the number was 0.93. Thus the shape of the REC curve remained almost identical. From Figure 31 one can see that also the level has remained unchanged. The growth trend for this real estate was less than 1 % p.a. in 1999–2002. However, this value is statistically uncertain, and growth could well be zero or negative. For the period 1994–2002 the growth trend was  $1.5 \pm 0.4$  % p.a. There didn't seem to be a clear temperature dependency in this real estate as can be seen from Figure 32.

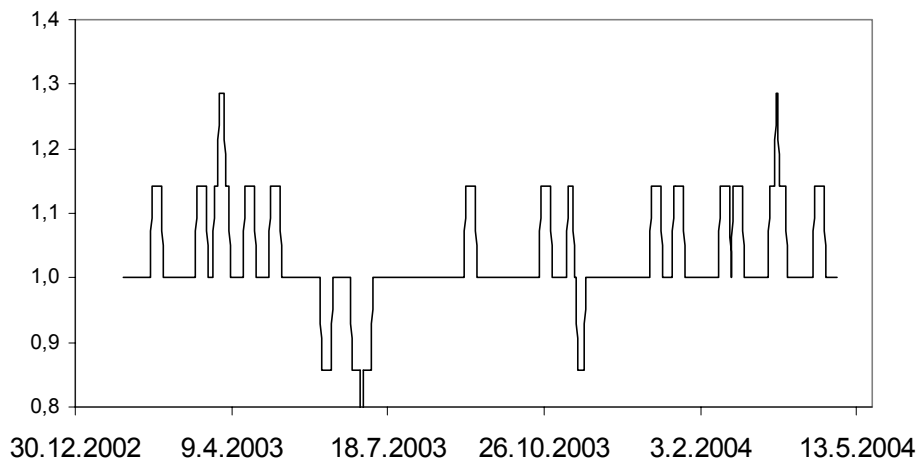

Figure 30. 7-day moving average of daily minimum REC's in real estate 13.

Figure 30 shows that there has been no change in the base load of real estate 13 between spring '03 and spring '04. The base load is around 1 kW, in the summer it can go below 1 kW.

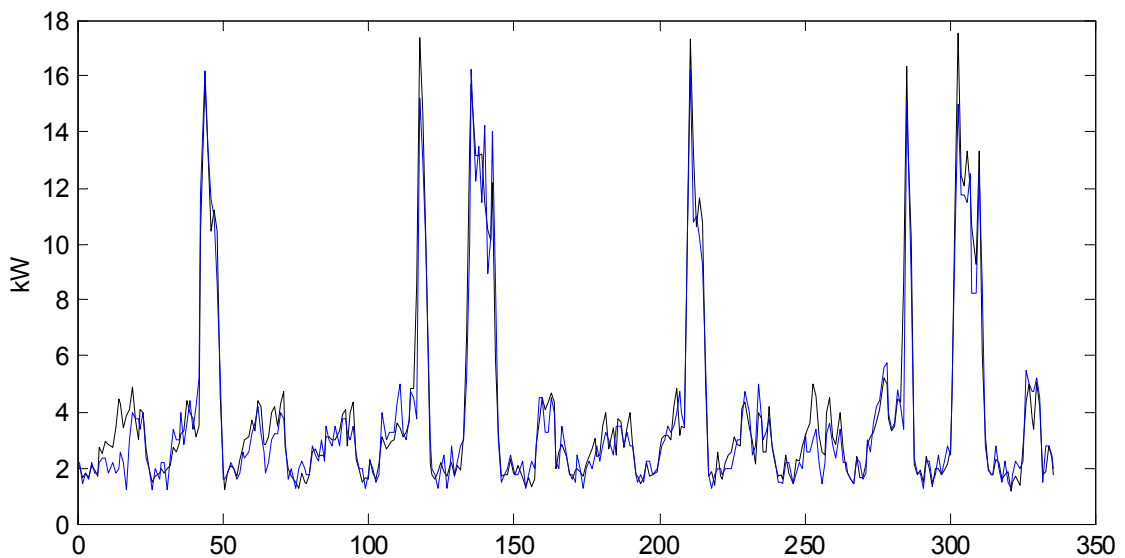

Figure 31. REC of real estate 13 March – April 2004 (blue curve) compared to the same period in 2001–2003. In the figure one month has been averaged into one week and thus two weeks are shown, 168 hours in each.

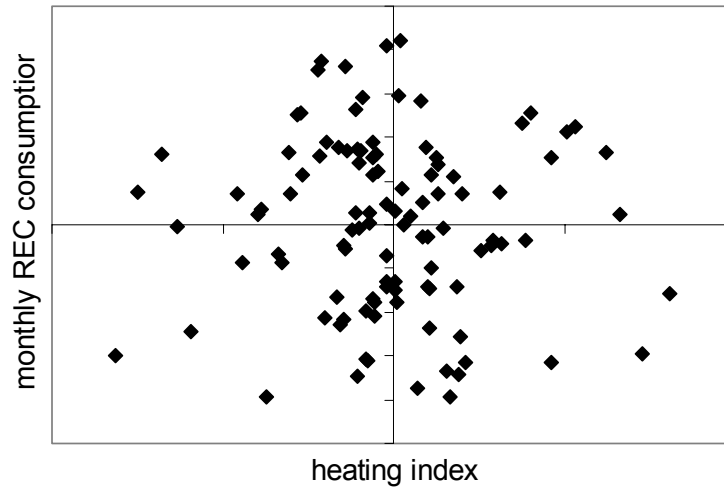

Figure 32. Deviations of monthly REC in real estate 13 from their monthly averages plotted against monthly deviations of heating indices from their averages.

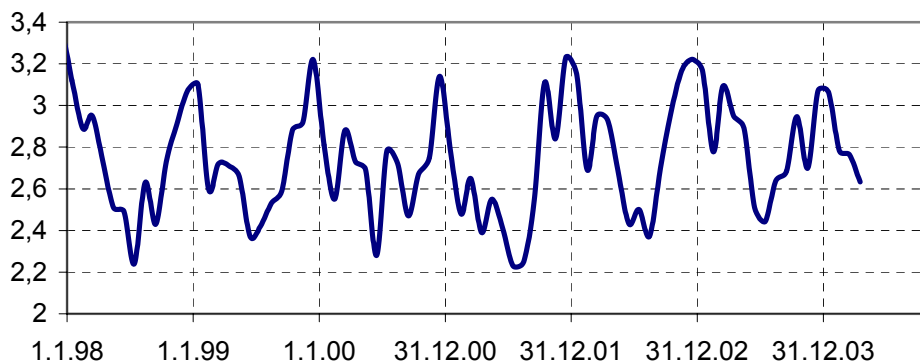

Figure 33. REC of real estate 13 from 1998 to 2004, monthly values in MWh.

Figure 33 shows the development of REC for real estate 13 from a longer period. It can be seen that although the change in spring '04 relative to springs 2001–2003 is an insignificant 1.5 %, the change relative to spring 2003 is more than 7 % and relative to springs 2002–2003 about 6 %. Note that no temperature dependency was found for this real estate.

The energy expert in real estate 13 was interviewed. She had been an expert for more than three years. According to her own notion she had visited Kulunet monthly (according to log once in three months). She had not noticed abnormalities in consumption and had not taken action to reduce consumption. She had noticed the reduced consumption relative to spring 2003 but did not know the reason for it.

In real estate 6 the use of the newly created (Feb 2004) username was intensive. These were not used by the expert himself but the username was published and was used by other residents. Kulunet was not visited from this real estate prior to February '04. The growth

trend for this real estate was similar to real estate 13. Figure 35 shows the old and new REC curves for April. The new curve mimics the old curve very well. The mean consumption, however, was 6 % lower in April 2004 than in April 2001–2003 as is visible from Figure 34. This is a rather large decrease. The standard deviation in the detrended monthly data series 1994–2003 for April is 130 kWh or 2.2 % of the average consumption in 2001–2003. The decrease has been spread more or less evenly all over the curve.

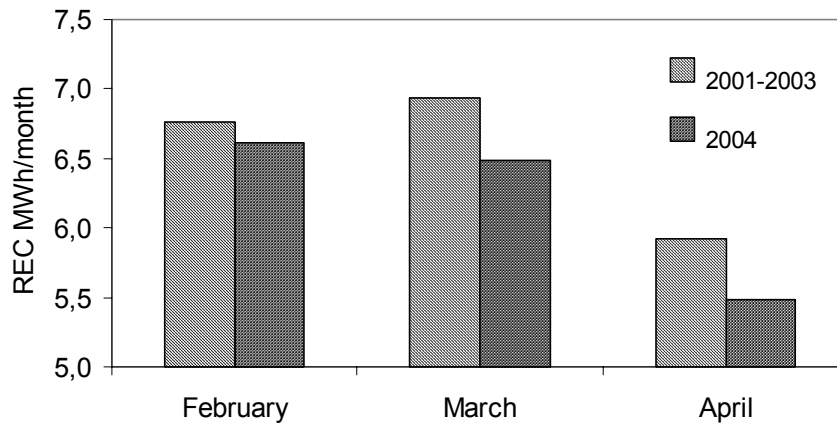

Figure 34. REC of real estate 6 in spring '04 compared to springs '01–'03.

In February '04 the decrease in REC is not yet present but in March it is. This of course coheres with the rising activity in Kulunet since February. Notice that in Figure 27 the decrease in February – April has been calculated to be 2 times the standard deviation in the detrended monthly data series.

Moreover, from Figure 36 it is possible to see the development of daily minimum REC of real estate 6 in spring 2003 and 2004. There is clearly a decrease relative to spring 2003. In other real estates there were no such clear changes. In real estate 30, however, there was almost 1 kW drop in daily minimum REC in March '03. April '04 had clearly lower consumption than April in any of the years 2000–2003.

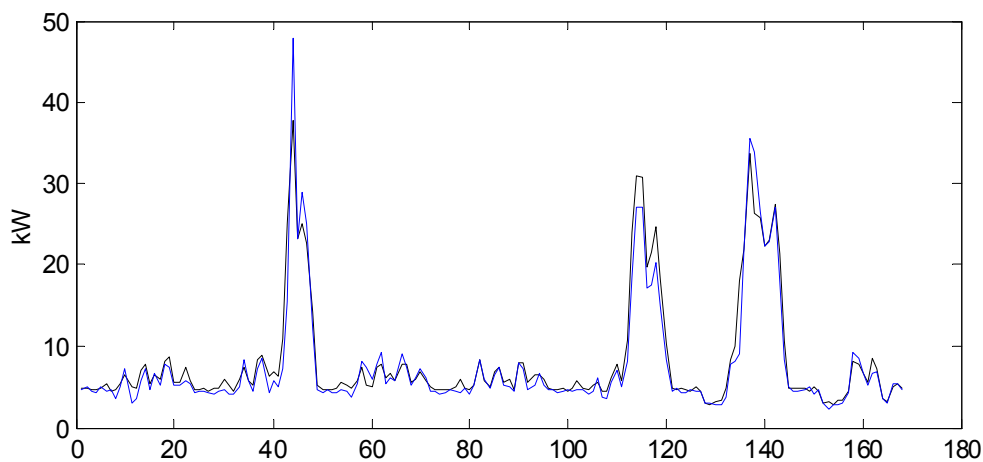

Figure 35. REC of real estate 6 April 2004 (blue curve) compared to the same period in 2001–2003.

*In the figure one month has been averaged into one week and thus two weeks are shown, 168 hours in each.*

However, it seems that this change is not due to improved feedback. The energy expert in real estate 6 was interviewed. He had been in the job for more than three years. He had not noticed abnormalities in consumption and had not taken action to reduce consumption. Also, there didn't seem to be a clear temperature dependency in this real estate.

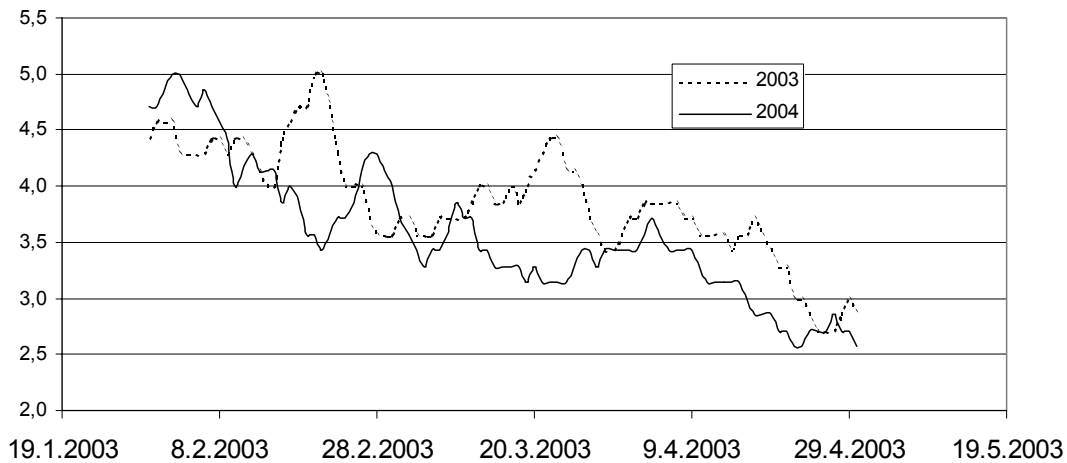

Figure 36. Daily minimum consumption of real estate 6 (kW, 7-day moving average). The dotted line refers to spring 2003 and the solid line to the same days in 2004.

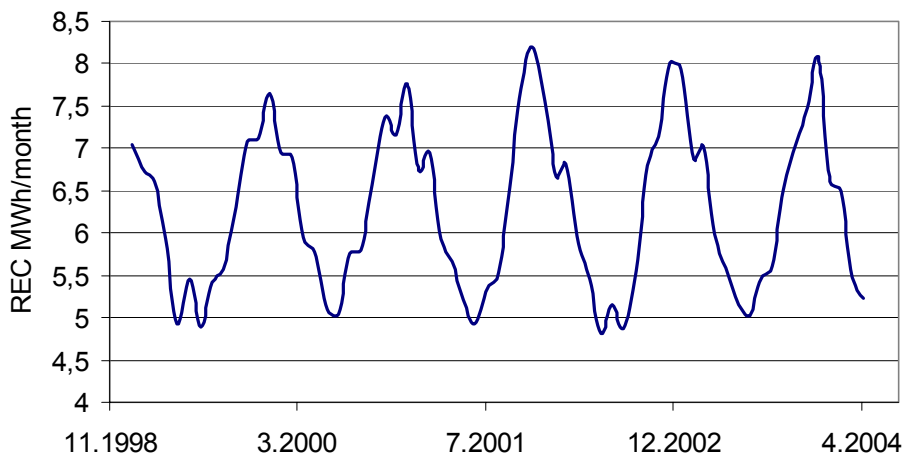

Figure 37. REC of real estate 6 from 1999 to 2004, monthly values in MWh.

The third active expert (real estate 25) was active up to August 2003 but according to interview had lost his username and had not used Kulunet after that. He had not noticed abnormalities in consumption and had not taken action to reduce consumption. Any of the active experts had not taken advantage of hourly consumption feedback.

### 3.2.8 Group-specific changes in REC

In section 3.2.4 the real estates were grouped into three different groups based on their real estate and total electricity consumption. In both cases the groupings were very much similar. Group one consists of older real estates. Group two consists of newer real estates with a greater number of heated parkings slots. Group three collected the four terraced houses. In Figure 38 the relative changes in the period February – April '04 have been plotted for each real estate in each group. Trends are not subtracted in this figure. When the high value (0.4) in real estate 9 has been neglected, the average relative changes for groups 1–3 are  $0.5 \pm 2\%$ ,  $7 \pm 5\%$  and  $-4 \pm 8\%$ , respectively. Thus there is a clear difference between groups 2 and 3. Based on Kulunet log there is little difference in expert activity between any of the groups. Both the active experts (real estates 13 and 25) belong to group 1.

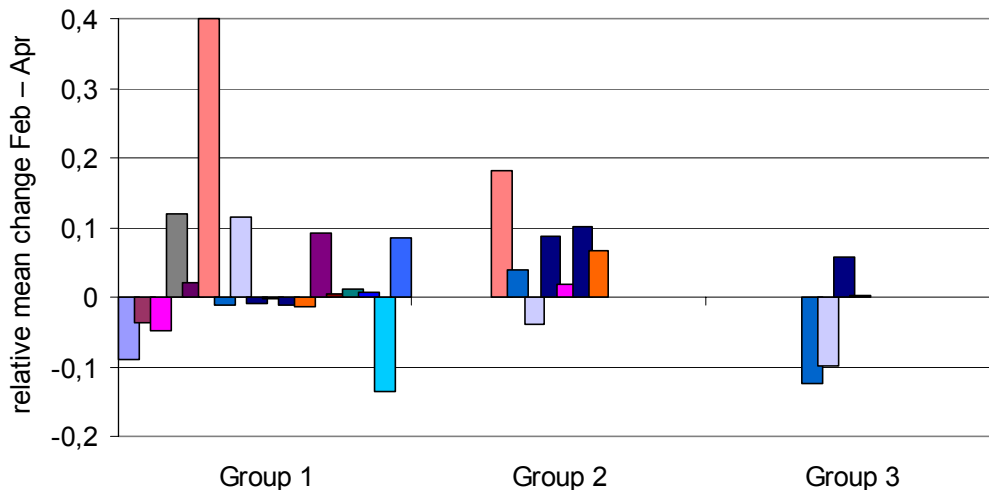

Figure 38. Mean change in REC in February – April 2004 relative to the same period in previous years (the number of previous years varies from one real estate to another).

There are not likely be major changes in the composition of the groups. Grouping was not performed on the newest data. However, since the changes in the shape of the curves are very small, groupings are not likely to change. Of course, the groups of those few ambivalent real estates, which do not fully fit into any single group, could change.

## 3.3 Monitoring of housing loads using forecasts

### 3.3.1 The real estate loads

One of the main results from the feedback information study was that the experts were not eager to watch regularly hourly consumption from the web, especially because it is not directly their own money spent in the real estate electricity consumption. Therefore an attempt was taken to see, if it is possible to predict the consumption and to set alarm limits for those cases where the consumption is changed (increased) for some reason. If this is possible

then the experts don't need to follow consumption changes, but they can get automatic alarms if the consumption is deviating from the normal one.

High-rise blocks and other multiple-flat housings use a lot of auxiliary electricity for elevators, common saunas, lighting, car motor warmers etc. The individual flats have their own meters, so their consumption is not mixed with the housing load. Especially in Finland saunas which are common to the whole building are widespread, and most of the tenants have their own regular time slots for using them. It takes a lot of electricity to heat a sauna, so there will be very noticeable load peaks during sauna times. Car motor block warmers are used more irregularly, as their use depends on outside temperature. The time of day of possible use is, on the other hand, more regular, being mostly during weekday mornings.

As the load varies quite a lot during, for example, one week, it is difficult to monitor its deviation from normal on a short term basis (hours...days) without a time-of-day and day-of-week model. As there exists an abundant collection of special days, Christmas, New Year etc., they should be taken into notice in some way. They are difficult to model but especially they are not very suitable as comparison days for normal days.

### **3.3.2 General principle of EME Forecast**

EME Forecast is a day-based forecasting model, although the day in turn is managed at the hour level. It is able to forecast from one day up to several years ahead, and one may forecast the history as well.

The forecast algorithm is based on suitable comparison days, which are selected from the history data. The selection criteria is dynamic, taking day type (special days marked and managed according to selected calendar for target), day of week and calendrical nearness into account. Special days can be set to be forecasted according to their previous realisation, and they are never used as comparison days for normal days.

EME Forecast is a multiple-use forecasting model for all kinds of loads, ranging from single user to a utility load, where the load could as well be the heat demand instead of the electricity demand. EME Forecast is easy to implement, as it doesn't need any pre-analysis of the target load. It has features like automatic regression analysis of one explaining factor – usually the outside temperature- as well as different user selectable forecast error based correction techniques. The forecast error based correction techniques aren't very useful as the forecasts are used for monitoring the loads and detecting abnormal load behaviour.

The difference in the outside temperatures between comparison days and day to be forecasted can be chosen to automatically correct the forecasts using regression coefficients from a detached, automatic regression analysis process. The possibility was not selected in this case because in most cases the temperature dependencies were weak. Secondly we didn't have daily temperatures at our disposal.

### **3.3.3 Using EME Forecast as a load monitor**

Assuming the forecasts are accurate enough, we may use EME Forecast as a load monitor. We could have it giving an alarm when the load differs from forecasts by a given amount and for a given minimum time span. Housing loads are usually stable over time, and big step-wise increases indicate new large equipment, misuse or faulty equipment. Property

managers nowadays may have several housings to watch over, so a load monitor –with alarms- may come very handy for them.

Some forecasting parameters deserve to be mentioned, as they are useful for this case. The model allows the user to set a restriction on the usage of the N previous days as comparison days. This allows us to slow down the model reactions to load changes. For example, we may want to have 10 days usage restriction on the prior days to better capture load changes. Another serviceable parameter is the maximum number of comparison days to use, allowing several days to be selected. As the load behaviour of one day may be quite erratic, using several days' average gives a smaller error. If the load has experienced a permanent level change, the date of change may be saved and used as a history break-point for the target in question.

Special holidays will be notoriously difficult to forecast, because their behaviour will depend on both which day of week is in question and what kind of repercussions that has on a given target load. The user can define a calendar for each target load, but it is easier to allow even large deviations for special days before setting of the alarm. But for instance if the load has experienced a temporary load hike due to some abnormal reason, we wouldn't want those days to be used as comparison days. It is possible to add a day span to the calendar as special days, whereby they won't be used as comparison days in the future.

The forecasts may also be used as forecasts by the property manager or some aggregator of housing loads, who actively participates in the electricity market, to assess future loads.

### **3.3.4 EME Forecast test results**

#### **Test setup**

Real estate hourly loads from different real estates in Tampere were used to assess the accuracy and possibilities of EME Forecast. The loads were measurements between 24.1.2003 and 29.2.2004. The load time series were all in normal time, even during the summer. They were converted to wall clock time by EME Forecast. The measurements were given in kWh as integers due to the accumulating meter used. The forecasts were set to the first decimal. As the hourly loads most of the day were small (e.g. 1–3 kWh), the proportional error is by definition already large. Example: real value 1.9, meter value 1, forecast 1.8, real forecast error 5 % ( $0.1/1.9$ ), forecast error 80 % ( $0.8/1$ ).

A restriction of usage on 10 days prior to the day to be forecasted was used. Max 5 comparison days very selected.

The forecast results are presented here graphically. Some graphs have an upper limit curve added. EME Forecast can be asked to calculate the confidence interval upper limit with 95 % certainty.

#### **Forecasts results**

An example of a load suddenly gone haywire is shown in Figure 39. The target is a flat block at Teekkarinkatu 3 (real estate 23). The load experiences a multifold increase, which is seen both night and day. Perhaps there was a renovation ongoing, with powerful driers for wet

areas, or then not. A property manager could get an alarm, check it out, and mark the days as special days to avoid new alarms when the load goes down.

In Figure 40 the housing load of Housing Company Metallin murole (real estate 12) is forecasted for the days 28.3.–5.4.2003. Although the proportional errors at times are relative large, the overall impression is quite good. The sauna peak loads are found and reasonably well forecasted.

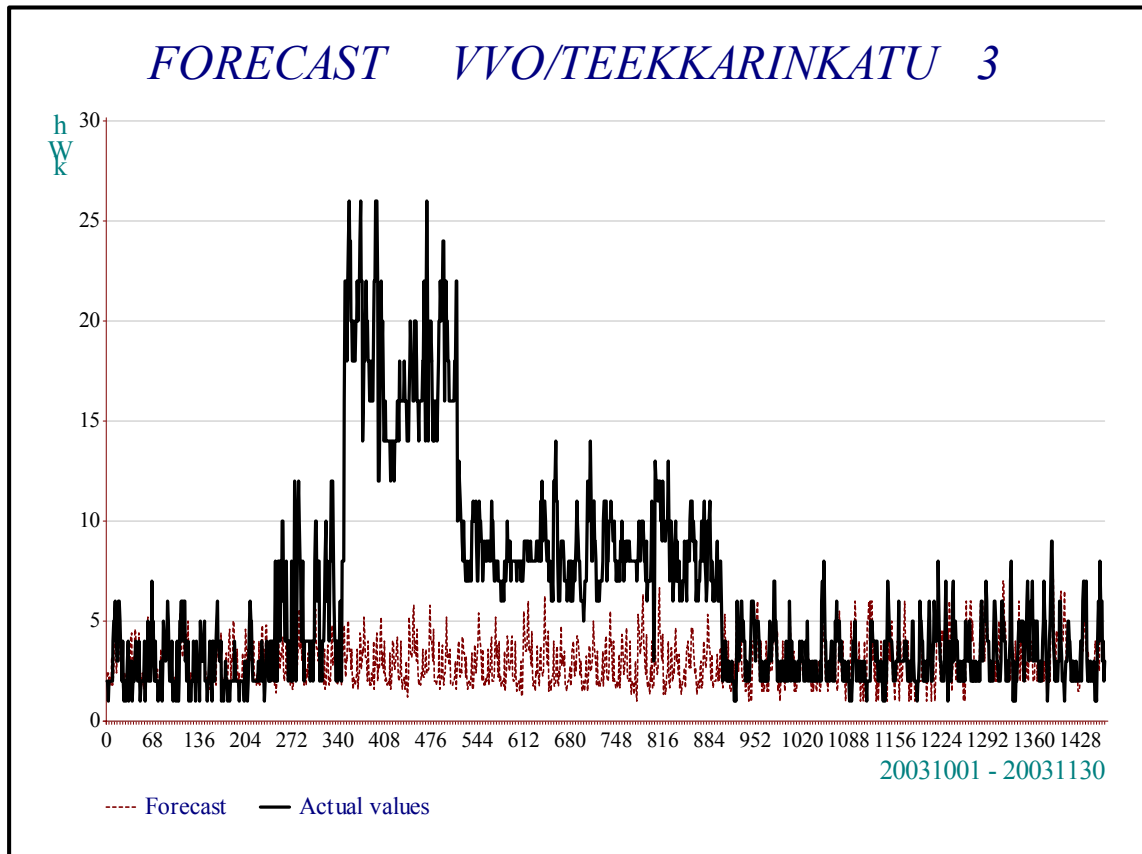

Figure 39. Forecast period 1.10.2003–30.11.2003. Forecasting exceptionally high temporary loads for target real estate 23. On the left, the forecasts slowly starts to follow the exceptionally high loads and results in overoptimistic forecasts for the end of the month. The striking difference between the load and the forecast could be used to set off an automatic alarm email to the property manager. On the right, a target specific calendar is used, where the day span 11.10. – 6.11.2003 is noted as special.

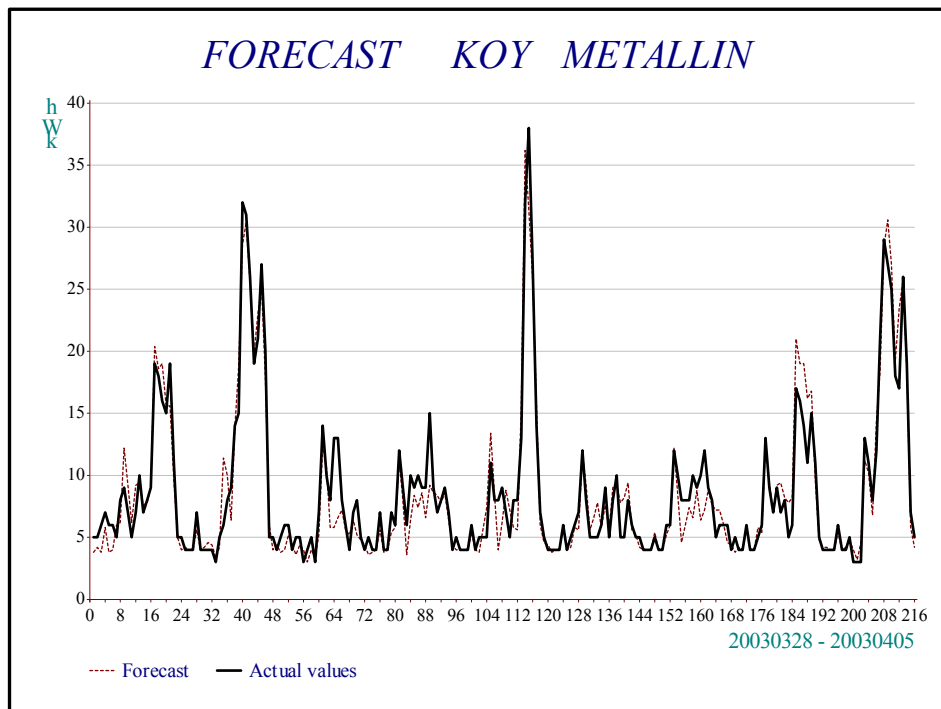

Figure 40. Forecast period 28.3.2003-5.4.2003. Target is KOY (Housing company) Metallin muole.

In Figure 41 we forecast Virontrörmänkatu 15 (real estate 29) during end of January 2004. The upper limit of the forecast confidence interval (95 %) is included. As can be seen, the load is mostly below the upper limit, but not always.

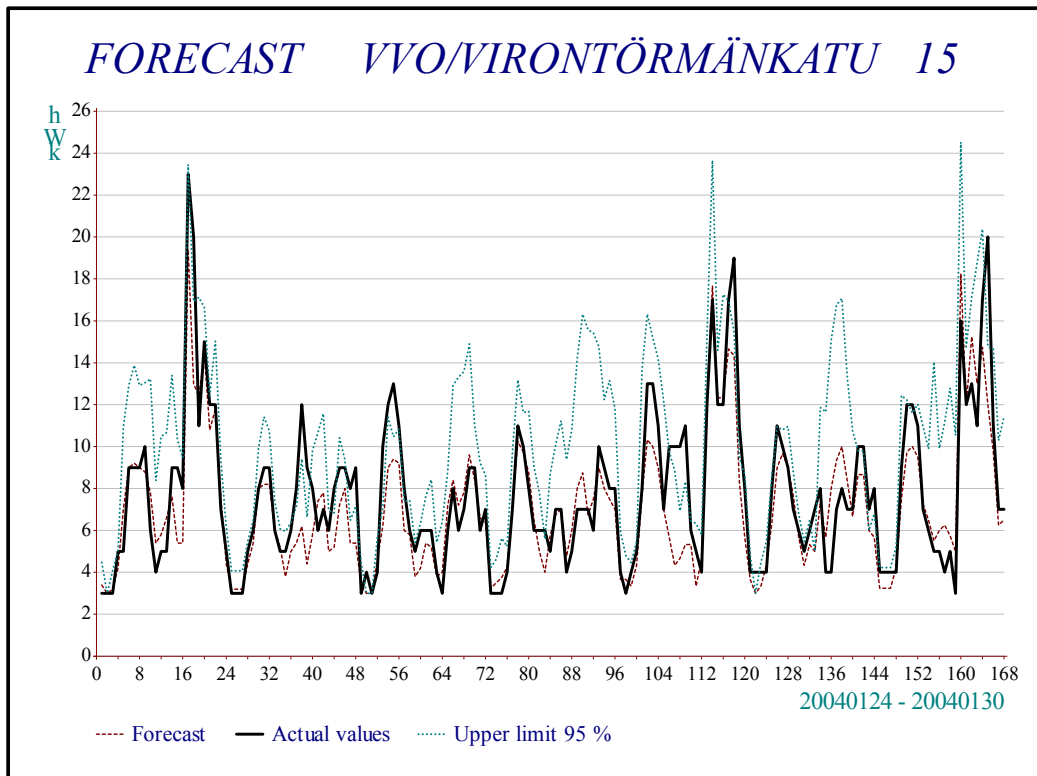

Figure 41. Forecast period 24.1.2004- 30.1.2004. Target is Virontörmätkatu 15 (real estate 29). Confidence interval upper limit added to the figure.

### Conclusion from forecasting

EME Forecast seems to be quite suitable for forecasting and monitoring real estate loads. These loads are reasonably regular, especially the sauna peak loads.

### 3.4 Results from the opinion poll

A questionnaire containing 18 questions was sent to the 31 energy experts in the pilot real estates on 25<sup>th</sup> May 2004. Ten replies arrived, which mean 30 % response rate. Six of the experts who answered had Internet connection at their disposal. None of them had to pay for the connection according to how much they use it. It is probable that the experts didn't remember to include telephone fee since they were not reminded of it. Broadband Internet connections are not yet very common in Finland.

Three of the 10 experts had noticed some abnormalities in electricity consumption during the past year. One of these said Kulunet was very useful in detecting the abnormality and one said it was of some use.

Several experts complained about insufficient training and information. From Figure 42 it is visible that lack of information is the most important reason why Kulunet was not used more.

From Table 4 one can see that the experts did not comprehend Kulunet as very useful and few of them were familiar with it (as is visible from the log).

Table 4. *Some results from questionnaire sent to energy experts.*

Question	Operationalization	Answers
"Was Kulunet useful to you in the work of energy expert?"	5 = very; 0 = no	average 1.5
"How well are you familiar with Kulunet service?"	5 = very well; 0 = not at all	average 1.0
"How often have you studied consumption using paper reports?"	4 = once a month 3 = a few times a year 2 = once a year 1 = more seldom	average 2.5

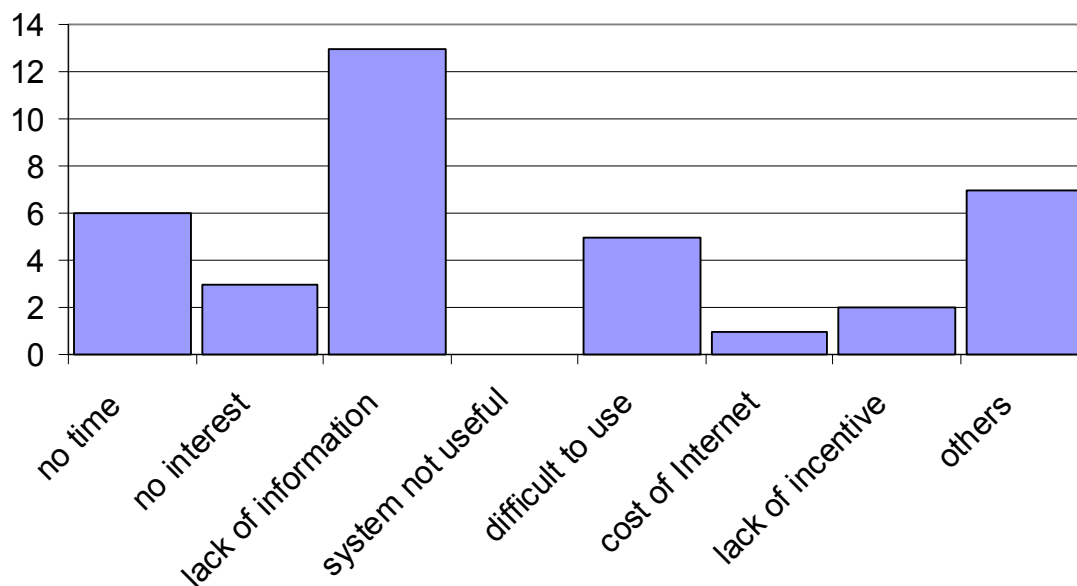

Figure 42. *Popularity of reasons why Kulunet was not used more. Experts could give 3, 2 and 1 points to the three most important reasons. The total points are shown on the ordinate.*

One expert said he has been following paper reports of energy consumption (provided to experts four times a year) more closely than before during the past year. Five experts said they are following paper reports as before; the rest didn't answer.

None of the answered had taken advantage of hourly consumption data. Most experts thought it would be relatively useful to have hourly consumptions, or they couldn't say. To the question about how difficult they think it is to take advantage of the hourly data the experts gave varying answers.

### 3.5 Conclusions

This study was about the effect of consumption feedback on consumption. Feedback was given through the web, on a site called Kulunet. The main responsibility of following each real estate's consumption belonged to so-called energy experts who are laymen residents living in the buildings. Consumption refers to real estate electricity consumption, which excludes the households' private consumption.

During the study the consumption feedback system was under development, which hindered providing full feedback to the experts in time. The development work also took work resources from the study. The feedback system was advertised to the experts but maybe not vigorously enough. The experts were not given enough training. They should be offered training several times a year. An expert who starts his job should be given a comprehensive information package. Also what is more important, one should remember that people respond to incentives. It is perhaps naive to expect that the energy experts would volunteer to spend their spare time for studying the complicated consumption curves without compensation. However, monetary compensation was not implemented because the administrative burden would have been too great.

Consequently expert activity in the Kulunet feedback system remained low throughout the study period. Creating Kulunet usernames for everyone in February '04 caused a considerable rise in the use of Kulunet. How much of this initial activity erodes away with time remains to be seen. So far a typical pattern with the experts seems to be that they get unexcited with Kulunet and their visits become more infrequent.

Three of the 31 energy experts in the pilot real estates visited Kulunet more than a couple of times. It is difficult to say whether this had an effect on consumption. There is a significant consumption change in one of these real estates (real estate 6), and also in another (real estate 13) if compared to past two years. According to interview the active experts had not noticed any abnormalities in consumption and had not taken action to reduce consumption. Therefore it is safe to say that feedback did not affect consumption of real estate electricity in this case.

A delightful feature is the popularity of Kulunet service in real estate six. It turned out that the expert had published the Kulunet username and password on their noticeboard as advised. The expert had not used Kulunet himself. This suggests that there is no point in hiding the consumption data from normal residents. There may be people among the normal residents who are more attentive and proficient in finding abnormalities in consumption curves than the energy experts. Also it is true that two people can see more than one. Thus to get full advantage of the feedback system, everyone should be allowed to use it. Naturally this places more load on the Kulunet server.

A common notion was that the hourly consumption data as such is too complicated for the energy experts to analyze. It should be divided into components so that the experts can see what portion of the power is drawn by each appliance. To some extent this would be possible by monitoring currents and voltages in the lines that supply the whole building by using so-called NIALMS-technology (nonintrusive appliance monitoring system). Unfortunately, this cannot be fully automatic. The base load, which is always present, cannot be analyzed in this fashion but each appliance must be measured separately. This is not cost-efficient for very small-powered appliances.

Anomalies can of course be detected, even automatically, by comparing old hourly curves with present ones. This is quite easy with a forecast software developed by VTT, which will possibly be integrated into Kulunet. But this doesn't help to detect if an appliance has been

drawing too much power from the beginning.

**References:**

Arvola, A. 1993: "Laskutuspalautteen vaikutus kotitalouksien sähkönkulutukseen" ('The Effect of Billing Feedback on the Electricity Consumption of Households'). Energy publications of the social psychology department of Helsinki University 10/1993.

Haakana, M., Sillanpää L. 1996: "Palautteen ja säästöneuvonnan vaikutus energiankulutukseen" ('The Effect of Feedback and Saving Guidance on Energy Consumption'). Yliopistopaino. ISBN 951-45-7375-7

Ministry of Trade and Industry 1994: "Normiohjaus energiansäästön edistämiseksi." ('Norm Control in Promoting Energy Save') Background survey of energy save program. Reports and studies of the Ministry of Trade and Industry 72/1994.

Therrien C.W. 1989: "Decision, Estimation and Classification". John Wiley. ISBN 0471504165.

## 4 French Pilot: Tempo: a real-time tariff for EDF mass-market customers

### 4.1 The context

In a monopoly situation, two basic principles underlay EDF's tariff policy:

- equality of treatment. That means that all customers with the same utilisation characteristics are offered the same rate;
- economic efficiency implies passing on to each customer the costs that he occurs to the power system.

Consequently the tariffs had to be a true image of electricity supply costs.

Before the 80's EDF used to propose:

- to industrial and commercial customers: seasonal day tariff (from 2 to 4 periods in a year, and from 1 to 3 periods in a day);
- two options to residential customers: a single tariff (one single price all day and year long), and off-peak hours (every day lower price for 8 hours).

Nevertheless these fixed periods did not allow one to cope with random factors (weather, generation failure...). Typically the increase of thermal uses has made the daily consumption very sensitive to the temperature.

Two options had been successively proposed to residential customers:

- the option named with the French acronym EJP (Peak Day Withdrawal) was made up of 2 types of days
  - 22 mobile peak days with a very high rate for 18 hours
  - other days with a low rate all day long.

This option has no longer been proposed since 1996

- The *tempo* option that divides the year into three types of random days: 300 blue days (the least expensive), 43 white days (medium price), and 22 red days (the most expensive). Each day is divided into two fixed periods: peak hours (day) and off-peak hours (night). The colour of the day is chosen by the national operating system at the end of each day for the next day.

The innovative nature of *tempo* has required the deployment of major technical and commercial means.

Consequently we can consider 3 main different steps:

- Experimental step (1989-1992)
- Launching step (1993-1995)
- Generalization, (after 1995)

This document presents both the experimental and launching steps.

## **4.2 STEP 1 – EXPERIMENTATION WITHIN THE RESIDENTIAL SECTOR**

Before launching the *tempo* option (1995), EDF organised an experimentation (between 1989 and 1992) in order to evaluate customers' reaction to prices and satisfaction level.

- **Who are the partners?**

Several departments within EDF (economic, technical, sociological, commercial, statistical...),

- **What are the target groups?**

Different customer classes have been defined according to their heating system, typically:

- only electric space heating
- electricity space heating and wood-burning fire place
- dual energy system (electricity + oil)
- heat pumps
- without electric space heating.

- **Pilot size**

800 customers in 6 different geographic regions (Alsace, Lorraine, Massif-Central, Rhône Alpes, Poitou-Charente, Ile de France).

- **Technology in pilot**

- electronic meters
- notification equipment set up to inform the customer about the tariff of the present day and of the day after
- energy management systems
- ripple control (one-way communication technique for sending tariff signal using the electric power lines).

- **Methodologies to measure and analyse the effects of the pilot on the customers**

Within the 800 customers' sample, 70 were subject to extremely precise measurements concerning their consumption. Their electric heating, hot water (storage tank) and total consumption were recorded every 10 minutes. Also available for these customers was information such as dwelling surface area, type of main heating, presence of automatic control units according to tariff commands for electric appliances, especially for heating, as well as external temperature.

- **Results**

The main result concerns the consumption reduction: on average for the sample the daily consumption has been reduced by 15 % on a white day, and by 45 % on a red day compared with blue days.

On average, the transfer of consumption from peak hours to off-peak hours was 1.3 times

higher on a white day than on a blue day. It was even higher for red days.

The reactions to prices were strong. The major consumption reductions concerned electric heating. Some customers reduced their heating consumption during the most expensive days either by using a fireplace or by accepting a lower indoor temperature.

It also appears that the behaviour of customers was extremely variable, even though they had the same electrical equipment. This variety of behaviour and adaptation is one of *tempo*'s strong points because it shows a great flexibility in the use of this option.

Another result is customers' satisfaction level: to evaluate it, the pilot has included a survey of these customers. The following results have been observed:

- 84% of the customers have been quite or very satisfied with this option,
- 59% have said that they had made savings (average or substantial for  $\frac{3}{4}$ ),
- 53% have considered the option as slightly restrictive or entirely unrestrictive,
- 87% have understood the tariff principle very well.

## **4.3 STEP 2 - LAUNCHING**

After 1993, every EDF commercial agency has been encouraged to propose *tempo* to its residential customers.

In order to ensure the tariff development successfully, EDF has had to work both on the economic, technical and commercial aspect. Moreover, EDF has defined an organisation aimed at obtaining a feedback after 3 years

### **4.3.1 From an economic point of view**

The GUITARES software has been developed in order to predict the tariff that was the most profitable for a customer according to electric end uses, size and insulation of the house or flat, number of family members. This software is able to calculate the customer's bill vs. the tariff (normal, off-peak, or *tempo*).

### **4.3.2 From a technical point of view**

EDF has promoted the development of new products:

- "Notification signal", a small box which can be plugged into any power socket and indicates the day's colour and the current hourly rating. It also indicates the colour of the next day as from 8 p.m.;
- Electronic meter able to manage the 6 tariff periods. It provides the same information as the "notification signal" box and also indicates the power level being used and the consumption per tariff period while allowing the remote reading of the meter by EDF.
- Various energy control systems. The most sophisticated energy controllers enable customers to program their energy consumption with a great accuracy and flexibility according to prices and chosen level of indoor temperature. They can

---

EFFLOCOM: Energy Efficiency and load Curve Impact of Commercial Development in Competitive markets

send messages to appliances through special cables or through the normal electric wiring (PLC).

Moreover, EDF has carried out analyses in order to ensure a high reliability level of its ripple control system through its distribution network.

### 4.3.3 From a commercial point of view:

- **Within EDF**

Training courses have been organised for commercial agents. These agents have received a small *tempo* suitcase containing different brochures explaining *tempo*.

- **Toward customers**

A whole range of services including the following technical products have been designed.

- **Decision-making services**

- ✓ A self-assessment questionnaire allows the customer to find out whether *tempo* is adapted to his life-style,
- ✓ An “Electric Heating and Domestic Hot Water” diagnostic may be carried out in the customer’s home, usually by an EDF representative,
- ✓ EDF also often carries out a customised tariff study described as the Right Price Advisory,
- ✓ And then 4 different versions of *tempo* linked to the devices able to manage the electricity consumption are proposed to the customer:
  - “standard *tempo*” using the meter to manage end-uses
  - “dual energy *tempo*” for customers equipped with a dual-energy boiler that can be switched automatically from one type of energy to another depending on the tariff rating.
  - “thermostat *tempo*”: a thermostat is set on each convector that adjusts the heating level according to electricity price
  - “comfort *tempo*” with a sophisticated system which manages various end uses (heating, water-heater, large electric appliances).

- **Customised start-up service**

Once *tempo* has been set, an EDF *tempo* specialist visits the customers to show them how to use the tariff, offer advice about their electric facilities and demonstrate how the electric meter works.

- **Permanent services**

After having completed the installation, it was necessary to ensure that the customer could easily get information about *tempo*. To do so EDF has used several ways:

- brochures such as “Bien vivre avec *tempo*” (How to live comfortably with *tempo*), the guide book “Comment profiter au mieux de la nouvelle option tarifaire *tempo*” (How to take the best advantage from *tempo*, the new tariff option) and the guide book “Confort Chauffage Electrique” (Comfort through electric heating),
- possibility to call an EDF employee able to answer any question about *tempo*
- one year after the signing of the *tempo* contract, EDF can propose an Anniversary Report mainly aimed to assess the billing differences over the whole year.

#### 4.3.4 The feedback after 3 years

Two means have been used to carry out this feedback: surveys and load curve measurement

- surveys

500 customers have been asked to answer questions after the installation of *tempo*. These questions concerned:

- the customers' features (dwelling, end uses, previous EDF contract...),
- the works in the dwelling linked to the installation of new devices,
- the starting with an EDF coaching,
- the global satisfaction level.

EDF has determined the features of a fictitious average *tempo* customer from this survey. This customer:

- Had an electric water heater,
- Had 4 big electric appliances,
- Had no air-conditioning system,
- Owned his dwelling,
- Lived in a family of four,
- Had been informed of *tempo* by EDF,
- Did not have an energy controller before *tempo*,
- Had an electric space heating and a fireplace using wood,
- Kept an indoor temperature between 19°C and 20°C,
- Had opted for standard *tempo*,
- Declared that starting *tempo* did not take more than one hour,
- Firstly asked questions about electricity price.

#### The main result is that 90% of the customers were satisfied or very satisfied

- Load-curve measurement

A pilot test including 150 customers has been organised in order to analyse customers' behaviour regarding electricity consumption vs. price.

From this pilot test, it has been estimated that:

- the customers have reduced their electricity bill by 10% on average (compared to the off-peak hour tariff),
- if customers have decreased the indoor temperature by 1°C on red days, the annual bill has decreased by about 4%.

### **4.3.5 Conclusion of the launching step**

At the end of the launching step, there were about 20,000 *tempo* customers (less than expected).

At this time EDF decided that:

- *tempo* would soon be introduced in the list of EDF tariff for residential customers whereas EJP would not be proposed any longer.
- in the near future the follow-up of *tempo* would be composed of:
  - consumption analysis for *tempo* customers,
  - a satisfaction barometer including two telephone surveys, the first approximately three months after the installation of *tempo*, and the second, one year later.

## **4.4 STEP 3 – GENERALIZATION TOWARD ALL MASS MARKET CUSTOMERS**

### **4.4.1 Evolution of the number of *tempo* customers**

The graph below shows that this tariff has been proposed to other types of customers since 1998 and that there are more than 300,000 domestic *tempo* customers today.

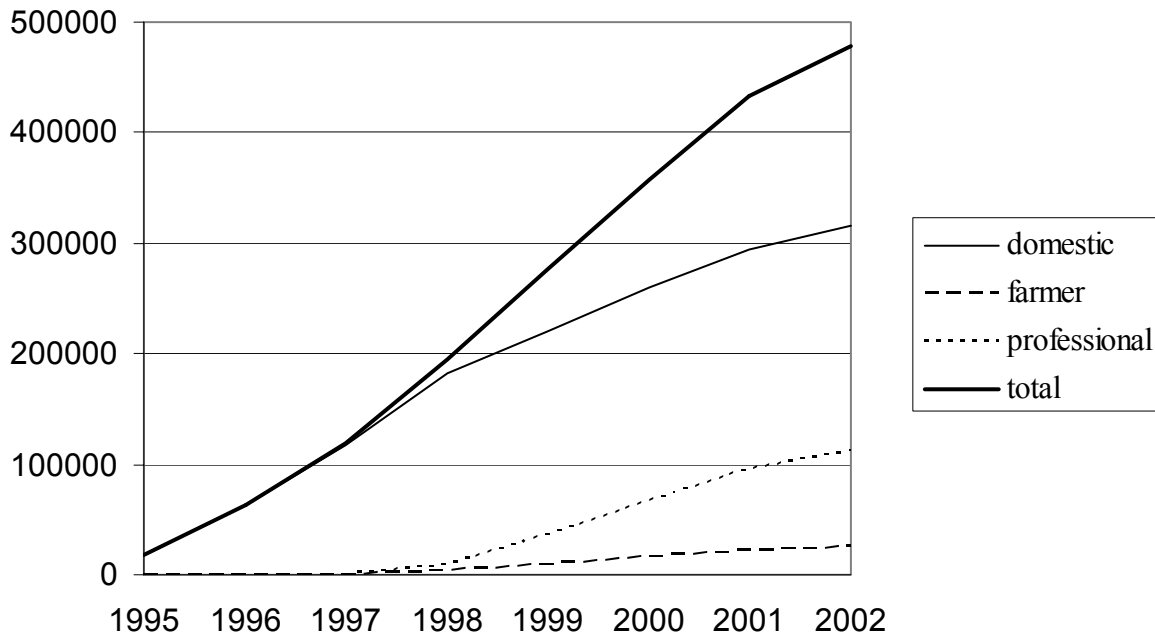

#### 4.4.2 Feedback

From the outset, a complete feedback had been constructed **on tempo customers**, with:

- a quarterly situation table, about the main characteristics (location, type of accommodation, type of heating, options...) of every new *tempo* customer,
- a satisfaction barometer, which consists on two telephonic surveys on the same customers: three months after tempo has been installed, and one year later,
- electricity consumption analysis.

With the two first tools, we have known that tempo customers were almost always living in houses, with a high average electric consumption (due to electric heating systems, and to many household electrical appliances). Most are families, and they own their accommodation.

Tempo is mostly chosen in order to reduce the electricity bills, and 92% of the tempo customers say they are satisfied with their new tariff. Their main dissatisfaction point is when they go through three or more consecutive red days (those with highest prices).

The last tool permitted to measure how EDF customers were appropriating this new tariff, and if they were playing the tempo game (with its differentiated prices) or not. In fact, most of them do, but with a simplification rule: some strongly reduce their consumption as soon as prices are not at their lowest; some take care only if prices are at their highest. Globally, the reduction effect is twice less on white days (middle price) than on red days (high price). We have observed that this consumption reduction is more or less stable over the years.

#### 4.5 CONCLUSION: tempo has been adapted to a monopolistic

## ***context and not to an open market***

### Marketing aspect:

The relative success of *tempo* is based on two strong elements:

- in the residential sector, electric heating, lowered during red days or replaced by using wood or kerosene,
- in the residential and professional sectors, a windfall effect for customers having a seasonal consumption with a less winter aspect than the rest of the customers, who take advantage of this tariff to make savings without a change in behaviour and, consequently, without an effect on the load curve.

In addition, those customers who opt for *tempo* and who appreciate it:

- have very particular customer profiles, with a "manager" tendency,
- are prepared to constrain their life and family to make little in the way of savings compared with their standard of living.

This, in fact, limits the distribution of *tempo*. That is why, despite a highly attractive price, the distribution of *tempo* has remained confined to less than 2% of the customers.

### Economic aspect:

The implementation of *tempo* corresponded to a monopolistic logic, with a marginal approach of the costs generated:

- the network part assigned to *tempo* was highly differentiated according to the types of days,
- the sourcing part was as well, from the nuclear marginal cost in summer off-peak hours to the failure cost in winter peak periods,
- permitting a ten-fold deviation between the most expensive and least expensive price.

The opening of the market has completely upset this construction:

- the network utilisation tariff applied, on the proposition of CRE (the French Electricity Regulation Commission), makes no difference between consumption according to its season,
- the historic valuation of the peak day withdrawal is not to be seen in the market prices, which have a lower amplitude than the marginal costs.

The *tempo* tariff is therefore totally unadapted today:

- for professional customers, it is over 20% too low and EDF requests that it be eliminated,

---

EFFLOCOM: Energy Efficiency and load Curve Impact of Commercial Development in Competitive markets

- for residential customers, it is too low and EDF is studying alternatives avoiding windfall effects.

The first studies show:

- that at a price level adapted to the costs considered in a competitive world,
- the discount offered to mass market customers (only a few %) will not be enough to justify the constraint brought about by this type of tariff.

**Only a determined approach, on the network tariff structure**, allocating a highly substantial part of the investments to peak consumption, while assigning only a low part of the investments to off-peak consumption, will make it possible to apply prices that are sufficiently differentiated to be attractive to customers of the mass market. An incentive system at the sourcing level rewarding those suppliers who encourage their customers to reduce their consumption during peak periods, would also make it possible to rebalance the system.

Finally, the technical aspect also has to be taken into consideration:

- setting up *tempo* means having to change the customer's metering system, which is complex and costly,
- managing the tariff signals in real time requires a reliable tariff order transmission system

## **5 Norwegian Pilot 1: Implementation of Demand Side Management in Oslo**

### **5.1 Introduction**

The Norwegian project “Implementation of Demand Side Management in Oslo” is by the Norwegian sponsors of the EFFLOCOM project defined as an EFFLOCOM pilot project. This means that the main results and general conclusions from this project are available for the EFFLOCOM project group.

A huge potential for postponing reinforcements at different grid levels through intelligent energy solutions among the customers is documented. It is possible to reduce or curb the peak load with 10-15% in a city area within a 3-4 year period. This implies energy efficiency actions such as building automation including load control, ordinary rehabilitation and converting from electrical heating to district heating or other energy carriers. For the network owner<sup>3</sup>, the project has shown that DSM actions in a certain city area can be realized at a 30% lower cost than the costs of grid reinforcement. The pilot project is focused on motivation of the customer, as well as technical and economical approaches of DSM.

### **5.2 Project overview**

#### **5.2.1 Objectives and summary of project facts**

Main objective: Avoid/expose planned grid reinforcement with use of DSM (energy efficiency actions). To postpone planned grid reinforcement, the pilot project was to achieve 10-15% peak load reduction in two different grid-areas. The second objective was to increase knowledge about electricity customers behaviour and compose a motivation model that can be used by the grid-owner and his coadjutant partner for energy economising. This motivation model should prepare for establishing appropriate routines for DSM within the grid-owner organisation.

Objective - removing barriers:

- For the customers: Through dialogue with different kind of commercial and household customers, possible barriers, which can effect implementation of energy efficiency actions, were mapped. Motivation analyses and model tools were made. The model/analysis deal with barriers connected to owner structure/organisation, type of customer, type of actions, cost-benefit from the actions, different ways

---

<sup>3</sup> Viken Nett was renamed to Hafslund Nett the 20<sup>th</sup> of April 2004. In this report Viken Nett is referred to as Viken, the Network Company, network owner or the grid owner

EFFLOCOM: Energy Efficiency and load Curve Impact of Commercial Development in Competitive markets

(besides tariff) of affecting customers energy consumption, DSM working methodology for the grid-owner and his coadjutant partners for energy economising etc. A proposal of motivation model is given in Figure 59.

- For the grid owner: Through a continuous dialogue between the project group and the staff working with grid reinforcement, there is made a recommendation for how to make use of the project results within the grid owner's organisation. Figure 43 displays a summary of this recommendation.

Table 5. Overview of basic data of the Norwegian pilot "Implementation of DSM in Oslo"

<b>Summary overview – Norwegian - pilot IDO</b>	
<b>Project title:</b>	Implementation of DSM in Oslo (IDO)
<b>Project period :</b>	1998-2001
<b>Economic size :</b>	1,5 Million €
<b>Sponsors :</b>	Viken Nett, Norwegian Research Council, Enova , the City of Oslo, Norwegian Electricity Industry Association
<b>Executive :</b>	E-CO Tech, Viken Nett, Sintef Energy Research
<b>Motivation of the sponsors :</b>	Energy efficiency as an alternative to grid reinforcement
<b>Project angel :</b>	Case studies, evaluating customer motivation, implementation of actions, analysis of the influence from the energy efficiency actions on bottlenecks in the grid.
<b>Number and category of customers involved :</b>	40 commercial, 156 block- and 17 row house residential
<b>Method of attack for involving the customers, tariffs?</b>	a) Subsidies of energy auditing and energy efficiency actions b) Letting the customer choose from costs of grid reinforcement or « free » load control. c) The existing standard tariff was used to give the customer incentive for energy efficiency.
<b>Examples of energy efficiency actions, smart house :</b>	Renovation of buildings, smart house solutions, replacement of energy carriers, load control..
<b>Direct communication to the customer? (Yes/No) :</b>	Yes, remote load control in 1 of 3 case studies.
<b>If yes, technology for communication :</b>	In one of the case studies: Ebox based on Internet and wireless radio communication.
<b>Test related to web based energy efficiency info :</b>	In one of the case studies: The customers were able to control their own electricity heating via internet. (Temperature and ToU) Contemporary the project was able to overrule the electricity heaters by lowering the temperature with 1-2 degrees in limited time period.

### 5.2.2 Project angle and methodology

DSM action as an alternative to grid reinforcements is solely based on cost-benefit:

$$\Sigma C_{\text{DSM}} \leq \Sigma C_{\text{Grid reinforcement}}$$

Where:

$\Sigma C_{\text{DSM}}$  – the utility's total cost concerning implementing DSM actions

$\Sigma C_{\text{Grid-reinforcement}}$  – the utility's total cost concerning grid reinforcement actions

In its simplest way, the philosophy is based on the fact that every shortage of electric capacity can be approached by either reinforcing the already existing distribution network to meet the future demand, or on the other side try to adjust the consumption to the capacity that already exist. The latter means implementing DSM actions. The way to go, are simply decided from a cost-benefit analysis, where all costs concerning the alternatives are taken into account and the cheapest alternatives are chosen.

In several cases, DSM actions are profitable compared to conventional grid reinforcements. However, for the utility, one has to make sure that the actual DSM actions serve as remedial actions concerning capacity problems in the distribution systems.

This meaning that the utility has to make sure that all suggested actions are followed up and actually implemented with the customers. All experience shows that customers have to be strongly motivated to implement energy efficient actions, in spite of the fact that the customers will reduce their own costs.

Planning and design for conventional grid reinforcement actions are well described tasks with predictable parameters. However, DSM actions in Norway represent an approach where the methodology and parameters included are not so well defined.

The results gained throughout the project have given valuable experience concerning procedures, methodology, possibilities and barriers for carrying out energy efficient actions.

Based on project experiences, a working process for the network planning considering DSM was established. The flow chart diagram in Figure 43 below shows the project's recommended approach of how to evaluate and consider DSM actions as an alternative to grid reinforcements.

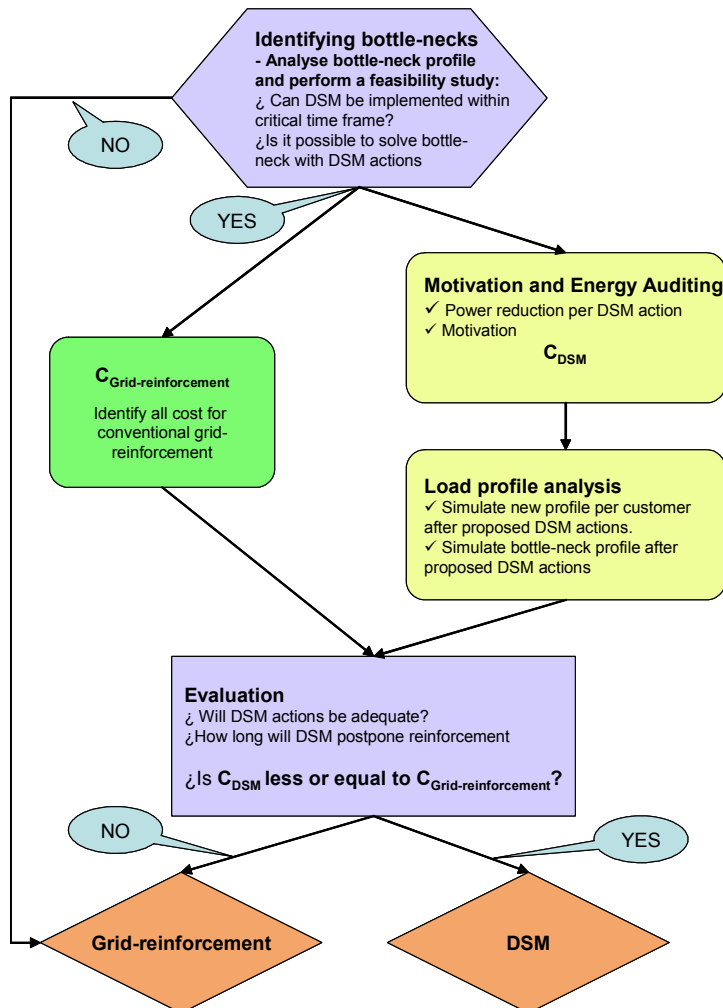

Figure 43. Flow chart showing methodology for considering DSM actions

### 5.2.3 Identifying bottlenecks

A bottle-neck means a grid constraint due to load exceeding capacity. The bottleneck can appear in different parts of the network, e.g. a power transformer in the substation, distribution transformer, lines or cables in any part of the distribution network (MV or LV). The ordinary way to solve such a problem is to install larger transformers and/or larger lines or cables.

Bottlenecks are identified through supervision and load forecasting. To be able to consider DSM actions, one has to gain knowledge of the load profile of the actual component or section. Through measurement and time registering of the peak load, analyses of the profile

will tell when the problem will arise. What time of year, what time of the week and most important, what time of the day will there be a capacity problem?

By conducting a rough search of the network- and customer information system of the utility, one can get an image of what kind of customers and consumption that are served by this particular section of the network. By concentrating on the largest consumers, one can sort out the consumers that are hourly-recorded (in Norway, all customers with an annual consumption above 100 MWh/year are hourly metered). Next step will be to sort out the actual consumers with a load profile that coincide with that of the bottle-neck's profile.

Once this is accomplished, one can establish from empirical data whether it is possible to meet the capacity constraint with DSM actions. In addition to consider the potential peak-load reduction of these customers, one also has to consider the time frame from when the capacity problem will arise with the time available for implementing DSM actions.

Experience from the project shows that a realistic time frame from initialisation of long DSM actions to achieving actual load reduction, will take at least 3-4 years. Generally most customers prefer to invest in DSM actions in connection with maintenance plans or other investments. Several other motivation key factors influence the time frame of DSM actions. These are studied more closely in later chapters. If a realistic potential for load reduction through DSM actions is established, within a realistic time frame, one can move on to the next level, see *Figure 1*. Regardless of the results from the above mentioned initial work, the conventional grid reinforcement alternative must be mapped according to the necessary technical actions and total cost ( $C_{\text{Grid reinforcement}}$ ).

#### **5.2.4 Motivation and energy auditing**

Based on the results from the previous activity, "Identifying bottlenecks", a certain group of customers are chosen for further studies. Each customer is to be contacted to be informed about the project and to map the status of the present energy consumption. Through the first contact with the customer the project has to clarify if the customer recently has made an energy auditing or done similar evaluation of the energy consumption. Moreover, the project has to map if the customer recently has completed energy efficiency actions and if the customer in the close future has plans for rehabilitation or extension of buildings. The next step of the project is to arrange meetings with each customer to evaluate the need and possibilities for energy auditing, as well as possibilities for realizing DSM actions. A second goal from the first meeting is to gather required information for further motivation work as described in *Figure 59*. In this project, all activity among the commercial customers regarding mapping and implementation of DSM actions were paid by the customers and the local authority in Oslo. In certain parts of Norway, including Oslo, there are possibilities for subsidies from the local authority regarding energy auditing and certain energy efficiency actions. To what extent the DSM actions are to the benefit of the network company, the possibilities for subsidizing the customer have to be evaluated. For instance changing the network tariff is one way to reward the customer for implementing DSM actions.

To achieve a neutral and a qualitative evaluation of motivational barriers among both residential and commercial customers, social researchers from Sintef Industrial Managements have been carrying out interviews of customers and motivational analysis (behaviour and attitude). The works of the social researchers have been accomplished in addition to the "motivation and energy auditing"- activities in the project.

### 5.2.5 Load profile analysis

Once the energy auditing is conducted and the different DSM actions are identified, the effect of these actions on the power system can be analysed. A model was established to simulate the new improved load profile for each customer, based on the detailed energy auditing with definite proposed actions for peak load reduction. The new calculated load profiles for each customer are added up, and then subtracted from the original load profile of the bottleneck. By analysing this “new” bottleneck profile, one can determine whether the DSM actions can solve or postpone the bottle-neck problem and thus serve as an alternative to conventional grid reinforcement.

### 5.2.6 Evaluation

Possible peak load reduction of DSM measures is compared to the load forecast in the particular grid area. Based on an expected progress plan of DSM actions of 3-4 year, a conclusion is made whether DSM actions will be sufficient for postponing the planned grid reinforcement or not. Figure 44 below shows a picture of how the evaluation is done. If DSM actions are considered as an adequate alternative to the planned grid reinforcement, estimated DSM costs ( $C_{DSM}$ ) and grid reinforcement's costs ( $C_{grid-reinforcement}$ ) is to be analysed using the Net Present Value method.

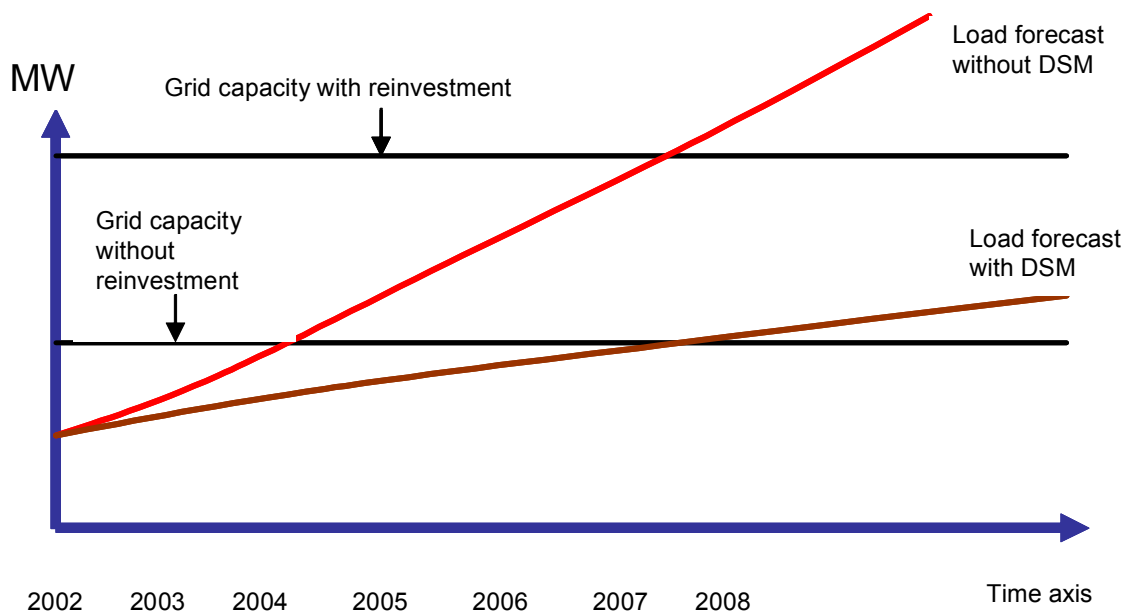

Figure 44. Example- Load forecast with and without implementation of DSM

Taken into consideration the exposure-period of the grid reinforcements that can be achieved from DSM actions, the net present value of  $C_{grid-reinforcement}$  is compared to the present  $C_{DSM}$ . Based on these evaluations a decision is made whether DSM action is to be an alternative to grid reinforcement or not.

However, in many cases the best approach might be a combination of both grid reinforcement and DSM measures. Then the most cost-effective DSM actions are chosen to reduce the level of investments otherwise required.

### 5.3 Pilot test 1- residential customers: Implementation of local load control of water heaters in 156 block of flats

Two different smart house concepts (DSM-actions) for residential customers were tested for respectively 156 blocks of flats and 17 semi detached houses. The achieved reduction of peak power consumption was up to 15% of historical maximum metered peak load (kW). Energy savings (kWh/year) were metered from +9% (increase) to -18% (reduction). The variation in the results was dependent on how the customers adjusted the smart house equipment as well as changes in the households' electrical equipment. The time horizon for realizing such DSM actions is empirically 1-2 years for residential customers.

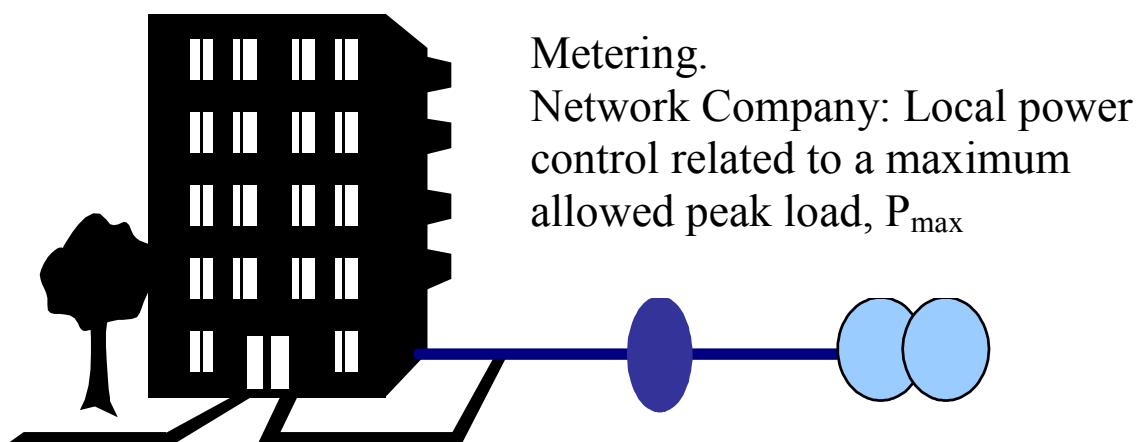

Figure 45. "Smart house – local solution" based on two-way communication inside the building

Local load control of electrical boilers was implemented in 8 blocks with 156 flats. The 156 residents represent a large group with wide variations.

Common for the two DSM actions which are implemented (test 1 and test 2), is that the network company is given the opportunity to control the energy consumption of the residents (water heaters and in pilot 2 also electric heaters). As shown in Figure 45 above, the local load control directed by the network company is limited by a maximum allowed peak load for the block residential customers. The block residents have equipment for power control which requires no involvements from the customer himself. The network company automatically controls the electric water heater in each apartment referred to the total peak load for the actual block. This is done without any impact to the residents' hot water consumption.

#### 5.3.1 Description of solution and technology

Figure 46 is a simplified sketch of the local load control solution which was implemented in 8 blocks of flats. The maximum load controller was delivered as a co-operation solution of the three suppliers-companies Klöckner, Nøbø Electro and Kvernland Elektriske. The concept solution consisted of a load controller, transmitter unit and relays/contactors in the fuse boxes of each apartment. The load controllers were placed on the supply line of each block and were connected to the meter measuring the consumption of each block.

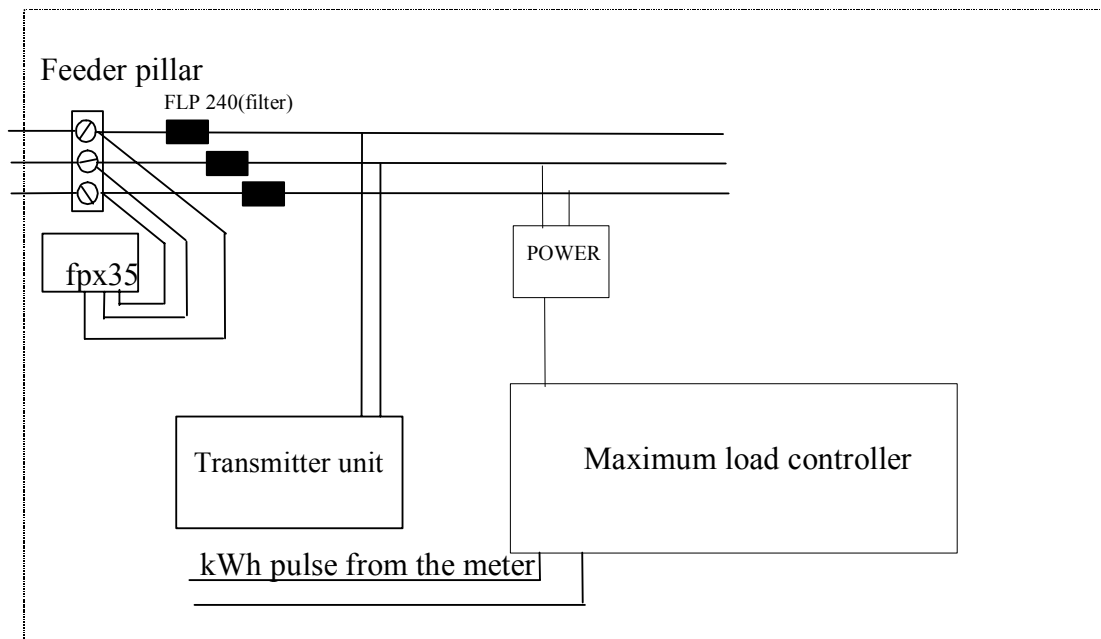

Figure 46. The connection of the maximum load controller in the switchboard room

The load controller has 14 digital output units which were connected to a transmitter unit. The transmitter unit communicated with the contactors in the fuse boxes via the electric network. The Figure 47 shows the Nobø Orion 512 which served as a transmitter unit for signals from the load controller to the contactors in the fuse boxes switching the water heaters.

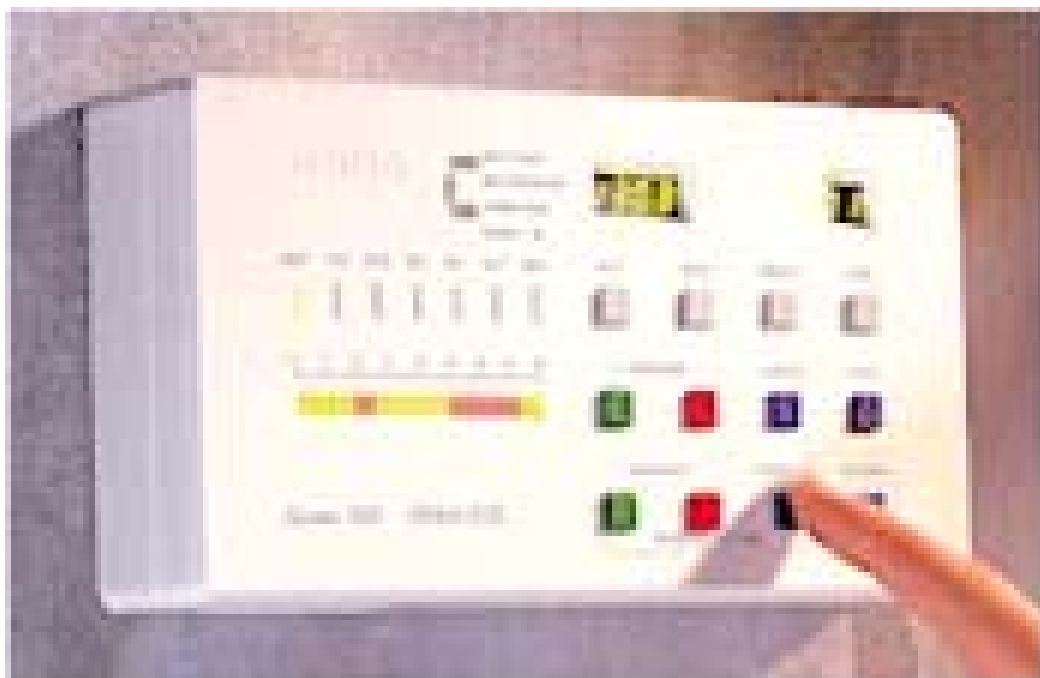

Figure 47. The load control system, program unit of Nobø Orion 512, produced by Nobø

This load control solution described above assumes that the electric water heater/boiler of each apartment has its own circuit to the fuse box.

### 5.3.2 How to involve the customers

All the participating residents are a part of a cooperative building society. The administrative board was given the possibility to participate in the implementation of DSM actions to avoid grid reinforcement. The reinforcement would involve paying about 62.000 Euro to the network company and extensive civil works in the surrounding area to the blocks. To participate in the project, avoiding the civil works was much more important to the building society than avoiding the required payment for grid reinforcement.

Dialogue with the chairmen of the board of the housing corps was vitally important to promote the project. The project won the boards confidence and participation was achieved through documentation regarding the alternative DSM actions and through written agreements.

### 5.3.3 Barriers experienced

The major part of the participants, 83%, answered positively to the question if they were satisfied with the network company controlling their electrical water heater without influencing their comfort. 6 of the participating residents have during two years of the project experienced some problems with access to hot water. The reason to this could be low boiler

capacity compared to consumption or faults with the boiler. The project experienced that all problems related to the boiler very easily was blamed to the project even if it was not the actual reason.

## 5.4 Pilot test 2- residential customers: Implementation of smart house concept in 17 row houses

### 5.4.1 Description of solution and technology

Both local and remote control of electrical heaters and boilers were implemented in 17 row houses.

The 17 residents represent a small test group with large variations. We find couples with adult children, couples with small children, single parents, single pensioners, and couples without children. Some of these are skilled in the use of computers and the Internet, while others are unskilled and without access. These row house customers have an active participation in the project through their possibilities to control their energy consumption manually or from an internet home page.

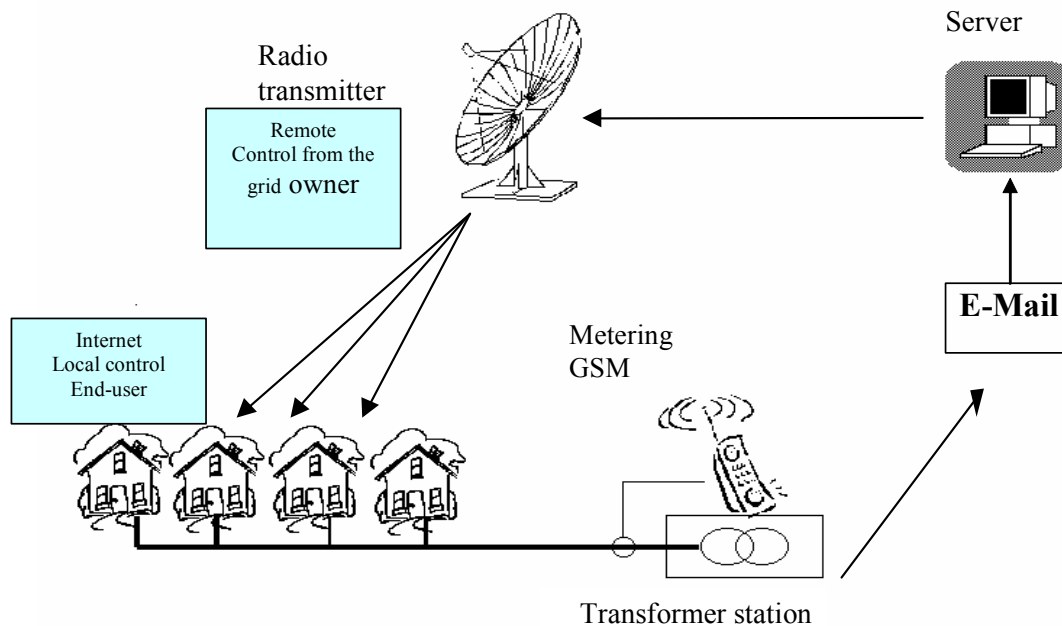

Figure 48. “Smart house – solution” Ebox based on Internet and wireless radio communication

### 5.4.2 Description of solution and technology

The following “plug and play” device, shown in Figure 49, was used to control electrical heaters and water heaters.



Figure 49. The Ebox – design and contents. Produced by Elink AS.

Generally, the Ebox is a programmable switch which can be plugged in the electrical outlet.

No installation or cables are required and the electric device which is plugged in the box can be controlled from an internet home page. Figure 49 above shows the design of the Ebox and gives an overview of contents and functions. The Ebox contains a data processor, thermostat, radio receiver, on/off switcher, a clock and a display. The load control (switching) can be based on room temperature level or time setting. Each Ebox has its own unique address and it can be configured from internet. When using the Ebox to control electrical heaters, the customer can make his/her own weekly temperature profile on hourly basis from a personal internet homepage. The desirable profile will be loaded from the operating server to the Ebox via radio signal. Using a button on the Ebox, the customer is also able to overrule the internet programmed profile. Because some of the 17 customers did not have access to internet, the project offered telephone service to help the customers establishing desirable temperature profiles.

The following picture shows an example of web interface that gave the customers a plain way of controlling their own room temperature according to their mode of living.

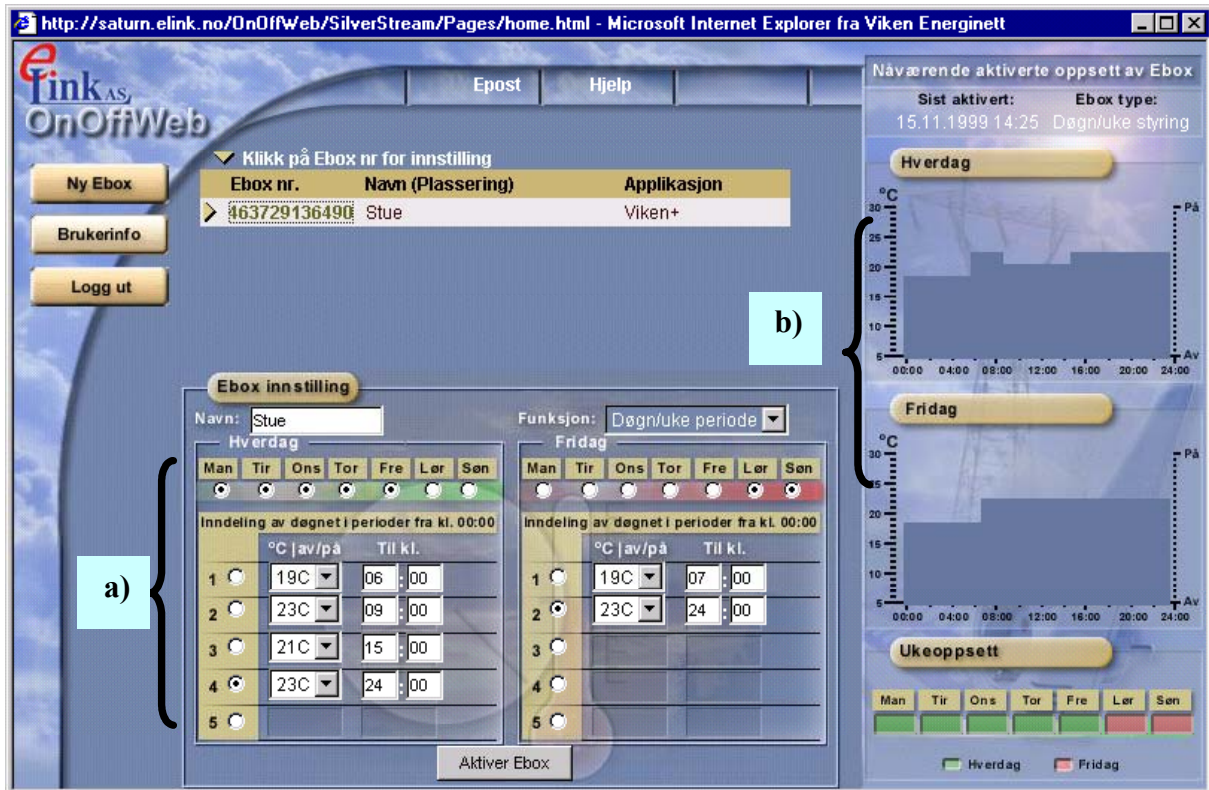

Figure 50. Each row house customer controlled their room temperature from such an web-page

Every row house participant was given a private homepage from where they controlled their Eboxes. An example of such a homepage is given in Figure 50. In part a) of the figure the room temperature is set at maximum 5 time periods per day. The days are categorized in working days and in holidays. The customers decide the number of temperature period a day and he/she also decides the distribution of working days and holidays. In part b) of the homepage the room temperature profile for working days and holidays is shown.

While each customer was able to control their own room temperature using their homepage for controlling the Eboxes, the Network Company (grid owner) simultaneously was able to overrule the same Eboxes in limited time period. As it appears in Figure 48, the Network Company remotely controls the Eboxes according to metered load in the transformer station. This transformer station represents the particular bottleneck in the distribution network.

### 5.4.3 How to involve the customers

Due to a possible bottleneck problem in a transformer station within the coming years, twenty row house customers were selected for this pilot test. The transformer station supplies all of these customers. Based on the goodwill achieved with the board of the building society in the pilot test 1, the project together with the chairman of the board sent a letter to these row house customers where they were invited to a meeting. The project presented the Ebox and how to use it. Each customer received cost free Eboxes, as well as user name and passwords for access to a private internet home page. The purpose of using the Ebox on this stage was to control all the important electric heaters in the apartments. When leaving the

meeting, it was up to each customer to make use of the Eboxes. After the (meeting) delivery of the Eboxes, the project visited the different customers a couple of times to help them if necessary. One year after the start-up meeting, each customer received one more Ebox with the purpose of controlling the water heaters in the apartments. The project experienced that 13 out of 20 row house customers decided to use the Eboxes throughout the test period of 2 years. Each customer was offered to keep the Ebox after the test period.

#### 5.4.4 Barriers experienced

The motivation for using the Ebox is linked to its functions as a device for private control of the cost of energy consumption, and a device that enables the network owner to control the peak load. The different members of the test group claimed varying motivations in relation to these. One part of the group was highly motivated and found it interesting to participate in the project as such. They wanted to test the technology and followed the project closely. They also thought that the Ebox worked well. Another part of the test group was *sceptical*. They considered it a duty to participate, and loyally used the device. To some of these the Ebox was a foreign body and not integrated into the household. Others used it actively even when they were not satisfied with its functions. A third group was mostly indifferent. They were not particularly conscious about energy consumption, and were prepared to pay the costs of electricity whatever they might be. The Ebox was installed, but they did not pay much attention to it and had not tried to adjust it.

### 5.5 Pilot test 3 - commercial customers: Implementation of various energy efficiency actions within a certain city area

Within a certain city area of Oslo, energy efficiency actions (DSM actions) were tried initiated among 40 commercial customers. In Figure 51 an overview of the 34 customers that agreed on participating in the project on the basis of a short introduction meeting, is presented.

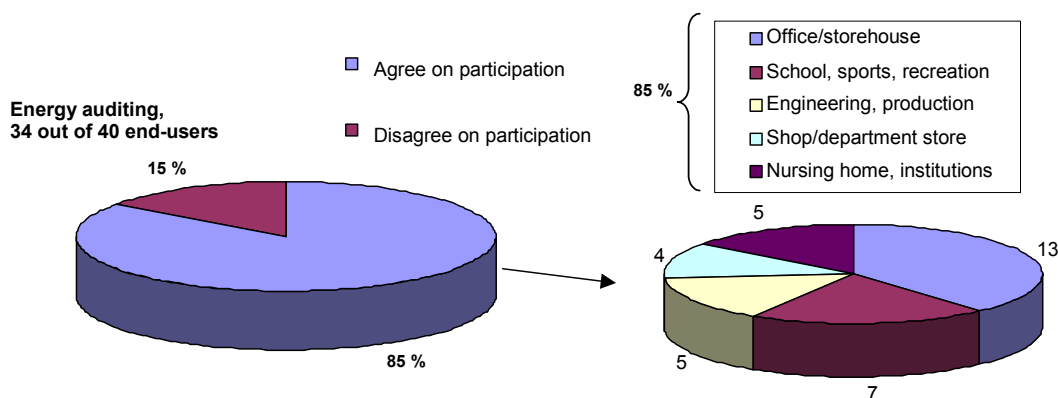

Figure 51. Overview of commercial customers which agree on participating in the project

The introductory sale of energy efficiency actions in the project was based on energy auditing resulting in integrated DSM-packages. Typical energy efficiency actions which were included in the DSM packages were replacement of electrical energy carriers, building

automation systems, renovation and maintenance of buildings, installation of new and more energy efficient equipment.

Before ending the project in 2001, 13 out of 40 customers started or were finished with implementation of the recommended energy efficiency actions. These implemented or planned implemented actions involved a peak load reduction which was divided in two different grid areas. For the two transformer substations supplying the actual customers it was estimated a peak load reduction of 3.7 MW (11%) from the existing 34.2 MW (substation 1) and 0.8 MW (3%) from existing 25.0MW (substation 2). The 13 customers have an estimated peak load at 15.7 MW. This implies an aggregated peak load reduction of 28.4% (4.46 MW) expected achieved within the end of year 2003. For the 13 customers, it is also estimated an expected energy saving at 25%, equivalent to 14.7 GWh/year. The experienced time horizon for realizing the DSM actions was 3-4 years.

### 5.5.1 Description of solution and technologies

There was a wide range of energy efficiency actions which were implemented among the 13 customers. In Table 6 the main categories of actions are listed up and sorted by the influence on the peak load problem due to the bottlenecks represented by two transformer substations.

Table 6. Category of energy efficiency actions sorted by peak load influence

Category of energy efficiency actions	transferring Peak load shaving and	- rehabilitation peak load curbing	Peak load curbing - alternative energy carrier
Regulating and time control of heating plants		x	
Maintenance - insulation, replacement of window/doors		x	
Light fittings - control and energy efficient appliance		x	
Energy monitoring system, courses/establish routines	x	x	
Ventilation plant - upgrade, demand control, time control	x	x	
Relocation of production - day-night	x		
Alternative heating: gas boiler / heat pump		x	x
Building automation system with maximum load controller	x		
Reconstruction for using district heating		x	x

It appears from Table 6 that the majority of energy efficiency actions which serves as remedial actions for the bottle necks (peak load reduction) were related to rehabilitation as the main motivation factor. In the following Figure 52 an example of one energy efficiency solution is shown for one of the office/storehouses.

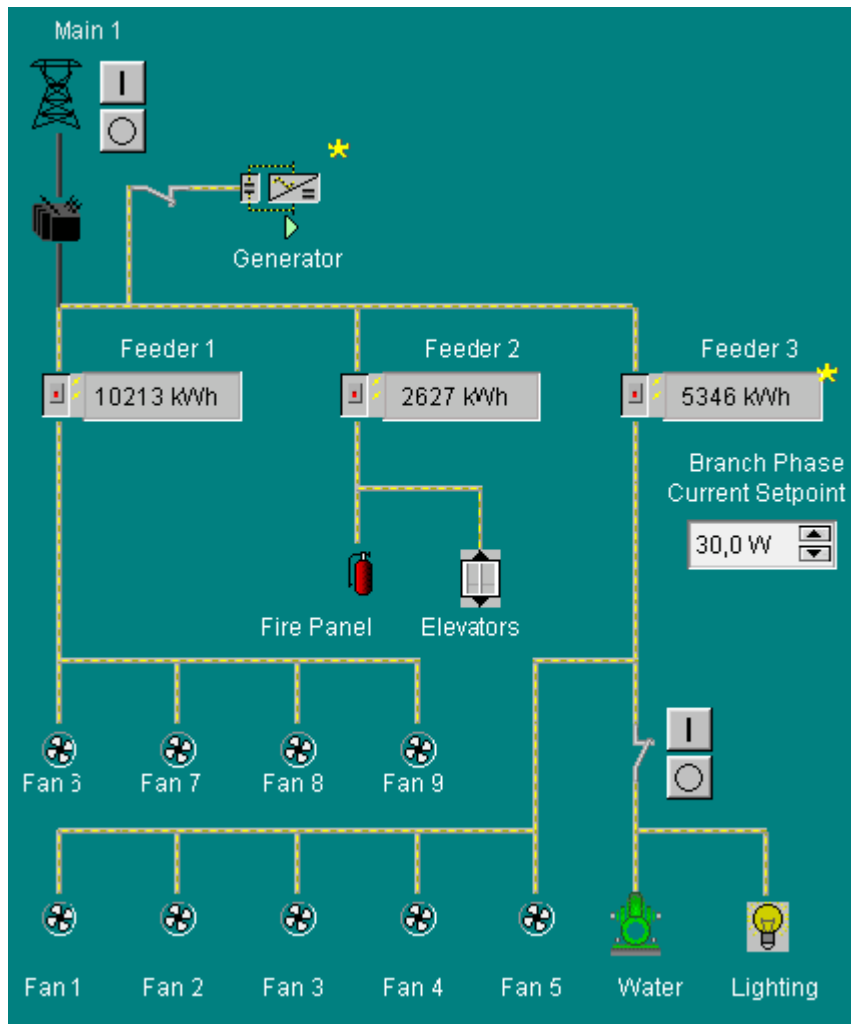

Figure 52. Siemens building automation system controlling loads supplied from different circuits

As shown in Figure 52, one of the customer implemented a building automation system with maximum peak load control and optimising of energy consumption. This intelligent building automation system controls for instance air-conditioning, hot water, lightning and elevators.

### 5.5.2 How to involve the customers

To achieve accomplished energy efficiency actions as an alternative to grid reinforcement, the customers have to be strongly motivated. Figure 53 shows an overview of the motivation-work throughout the project.

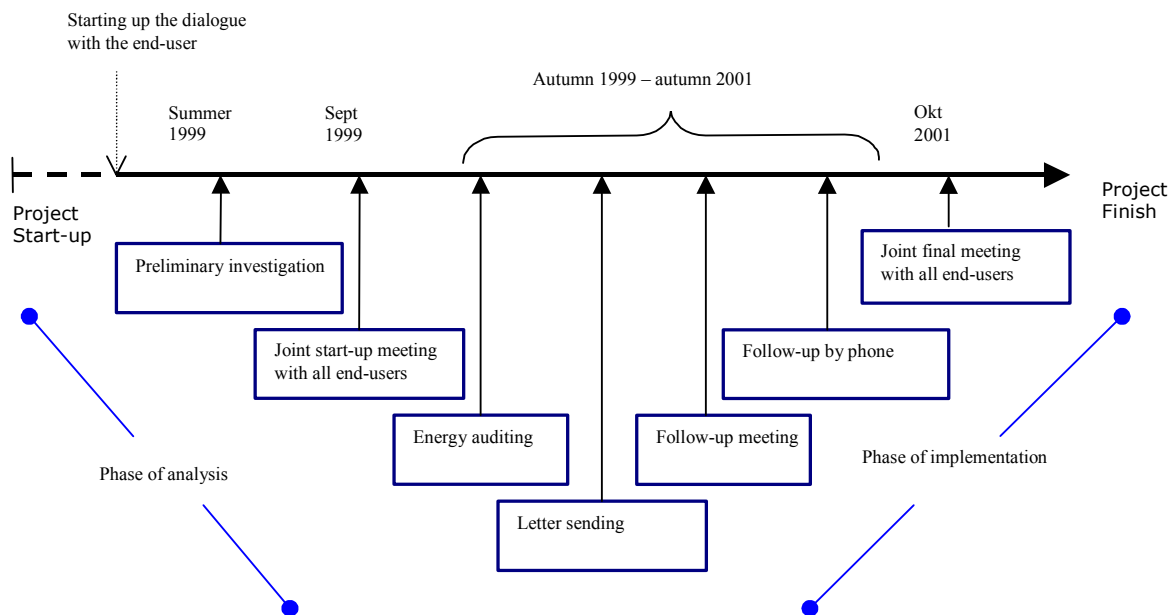

Figure 53. Methodology and progress of the project motivation-work

Based on a preliminary bottle-neck analysis, as described in Figure 43, 40 customers were selected for a preliminary investigation to map the interest of the project. This investigation involved a short meeting and the project explained the bottleneck situation in the grid and future consequences from not effectuate the project. Grid reinforcements and expected price increase of the Network tariff were some of the topics that were mentioned. During these preliminary meetings, 34 out of 40 customers confirmed that they wished to accomplish an energy auditing (see Figure 57). After a joint start-up meeting the energy auditing were started carried out. The customers were given improved incentives/motivation of implementation through subsidy of the energy efficiency actions documented in the energy auditing. The subsidy contributors were the City of Oslo and Viken Nett. The subsidies share of the action costs, appears form Table 9. Through the period of implementation, the customers were followed up by letters, meetings and phonecalls. Finally, the project results were presented in a joint meeting in the end of the project.

### 5.5.3 Barriers experienced

The pilot study experienced that several key factors were of vital importance to achieve implementation of energy efficiency actions:

#### b. Ownership vs. rent of premises

The experience shows that the organisation of the ownership itself is crucially important to companies' relations to DSM. Three main different organisation types were identified: Self-ownership: The most simple organisation model, when a company both owns and uses a building itself. In this case companies have usually a continuous overview over electricity consumption and have the least problems compared to others when it comes to evaluation of proposed DSM activities and further implementation of them. Companies belonging to this

group have a clear incentive structure: to minimise its electricity bills, minimise required investments and related risk exposures.

Single owner with several leaseholders: This is a common practice with several companies renting their premises from an owner company as shown in Figure 54. In this situation the owner usually covers a small share of electricity costs for common areas and transfers the major share of costs directly to his leaseholders.

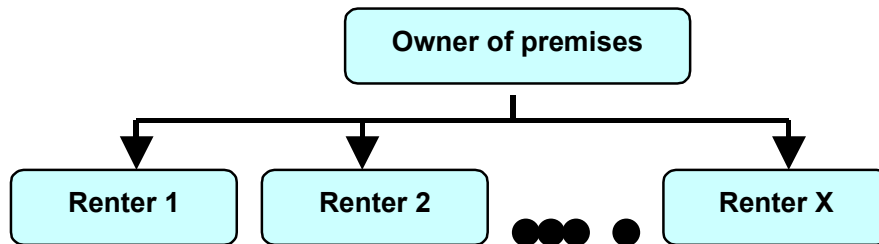

Figure 54. Owner of premises with several leaseholders (renters)

This leads to opposite incentives between owners and leaseholders: an owner wants to invest as little as possible in DSM, since electricity costs are paid by leaseholders. The renters wish to reduce their electricity bill, but usually do not have an opportunity to make the required investment.

The situation is even more complicated since rent contracts often have a fairly short duration (2-3 years) and have to be regularly renewed. Leaseholders do not want to commit any substantial investments since they may have to move to another building. Planning and implementation of DSM actions become complicated for owners since the situation becomes unpredictable in the long run. Additionally, implementation of DSM actions meet practical complications since certain types of activities have to be implemented at the same time in order to be efficient. Our experience shows that it becomes difficult to reach an agreement about this with leaseholders.

Joint ownership with several leaseholders: The situation is different when several companies own the premise in joint ownership, which is led by a manager as it is shown on Figure 55.

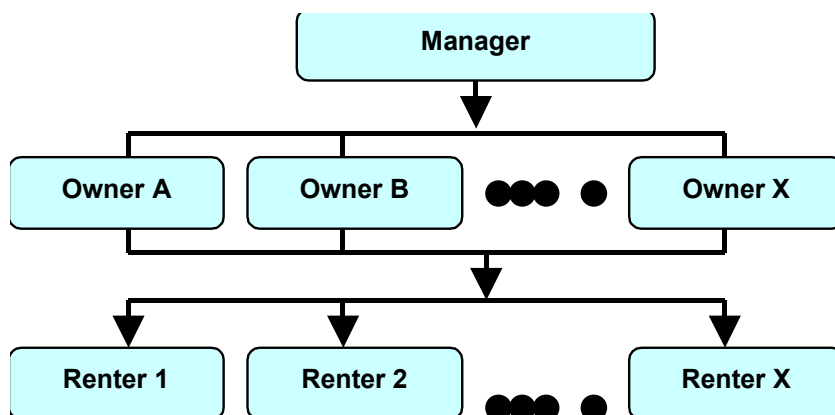

Figure 55. Joint ownership with a manager and several leaseholders (renters).

This model usually includes the same set of complications as the previous one. The decision making process in this type of company assumes that all owners are agreeing, which is difficult in practice when it comes to DSM-related investment.

*b.* Cost allocation

Allocation and accounting of costs related to electricity bring additional complications in implementation of DSM actions. As it was mentioned before, an owner of premises transfers electricity costs directly to leaseholders. Allocation of costs in companies, participating in the study, was done in two ways:

Each leaseholder had an individual electricity meter and paid according to the metered data

Leaseholders paid a share of the electricity costs, usually according to sq. meters of the rented floor space

The last variant creates additional barriers for DSM since it makes use of electricity anonymous and in practice removes all incentives from leaseholders.

*c.* Contact persons and decision making process

Both interest and personal engagement of those responsible for technical operation in a company have a crucial importance in planning, implementation and continuous follow-up of DSM activities. Competent persons should be informed about both the economic and technical sides of the company's operations. The experience shows that low interest, lack of responsibility or negligence from technical staff can complicate considerably both evaluation and implementation of DSM.

*d.* Financing of DSM and recovering of investments

Companies usually prefer to base their investment analyses on so-called payback period estimation. It is a relatively simple and easy to understand method for estimation of investment profitability over relatively short time periods. (For longer periods it is more appropriate to use Net Present Value method.) The experience shows that commercial customers prefer to initiate DSM activities with 2-3 year payback period, while DSM with payback periods exceeding 4 years are strongly opposed by company's management and usually rejected by owners (board of directors). On the other hand, companies are willing to accept DSM actions with longer payback periods if they have a maintenance-related profile, like installation of new windows, new ventilation, doors etc [5]. Commercial customers have pointed out that there is a considerable risk factor in DSM-related investments since the power electricity market has become highly volatile and unpredictable when it comes to spot prices. Possibilities in alteration of existing network tariffs may also contribute to a considerable risk exposure.

*e.* Financing of DSM and corporate organisation

Results from our study give the impression that companies and organisations have very different requirements to the financing of DSM. Private companies with relatively low-built horizontal organisation structure, decentralised financing and decision-making tend to require very high profitability from proposed DSM-actions and expect correspondingly short payback periods. At the same time, according to the contact persons, these companies are better positioned to commit the required investment as long as it is feasible from a financial point of

view. Other type of companies, usually public, have absolutely opposite behaviour: They consider approval and obtaining of the required investment to be the most complicated part, while the profitability of the investment and future operating costs are less important.

*f.* Electricity costs

Electricity costs usually have a relatively small share in a company's costs, when e.g. compared to labour costs. The result is that a company avoids implementing any DSM activities if they are expected to increase labour costs, as for example movement of energy-intensive production processes to low-load periods (night). Additionally, it may cause a conflict with existing legislation, regulative working norms and standards. Companies which traditionally used to work during night time, as for example bakeries, are much more flexible when it comes to adjustment of load profiles

## 5.6 Project results and key figures

### 5.6.1 Residential customers

In pilot test 1 the cooperative building society decided that the load control system should be installed in 156 block residents as an alternative to grid reinforcement which involved extensive civil works in the surrounding area to the blocks. Due to the decision made by the cooperative building society, the block residents had no other choice but participate in the project. In pilot test 2, 20 row house residents were recommended by the cooperative building society to participate in the project (make use of the Ebox). The development of participants in pilot test 2 is shown in Figure 56 below.

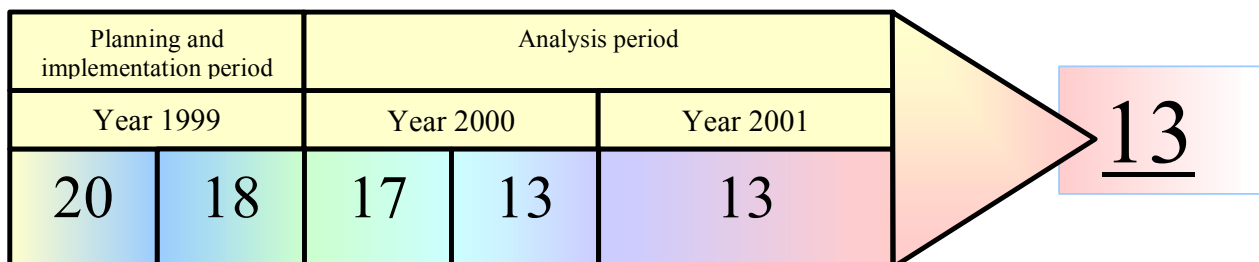

Figure 56. Development of number of participant in pilot test 2 – voluntary participation

It appears from Figure 56 that 13 out of 20 row house residents participated through out the project

EFFLOCOM: Energy Efficiency and load Curve Impact of Commercial Development in Competitive markets

Table 7. Peak load reduction based on sampling tests – load control of water heaters in block of flats

Blocks	Number of end-users	Measured peak load reduction				Preliminary estimate of potential peak load reduction	
		Min kW	Max kW	Min %	Max %	kW	%
A	20	5,6	6,8	10,7	13,1	8,7	11,3 %
B	29	8,1	9,9	9,2	11,2	10,7	9,6 %
C	24	6,7	8,2	8,0	9,7	11,3	7,6 %
D	24	6,7	8,2	8,4	10,2	11,3	9,1 %
E	12	3,4	4,1	7,0	8,5	5,2	6,8 %
F	12	3,4	4,1	9,3	11,3	6,1	11,6 %
G (ref)	17						
F(ref)	18						
Sum/average:	<b>156</b>	5,7	6,9	8,8	10,7	8,9	9,3 %
Average measured reduction:		<b>6,3 kW</b>					

In Table 7 the estimated peak load reduction based on sampling tests/measurements is shown for pilot test 1. In two of the blocks the implemented load control equipment was not activated. These two blocks were used as references and the residents were not familiar about the load control of water heaters was not operating. These two blocks were used to verify the measured results and were also used by the social researchers to verify surveys and interviews. Similar evaluations as in Table 7 were also completed for the 20 row house customers.

**5.6.2 Commercial customers**

In pilot test 3, preliminary analysis, there were selected 40 (out of 65) commercial customers. All of the 40 customers were offered help from the project in the form of an energy auditing. Dependent of the extensiveness of the energy auditing, they had to pay for the energy auditing them selves. The development of participants in pilot test 3 is shown in Figure 57 below:

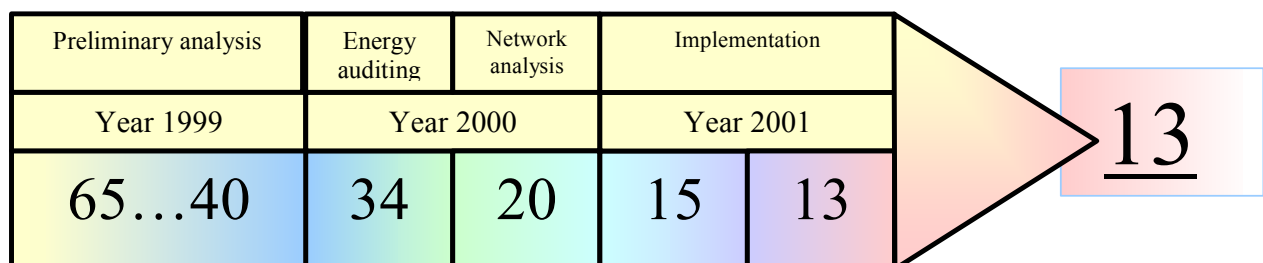

Figure 57. Development of number of participant in pilot test 3 – voluntary participation

It appears from Figure 57 that 13 out of 40 commercial customers participated through out the project, which means that 13 commercial customers implemented energy efficiency actions according to the projects recommendations (energy auditing).

Some of the most important results for the network company are the experienced costs of initiating DSM actions. In the following key figures for DSM costs in Table 8 it is important to notice that the cost of energy efficiency actions are paid by the customer himself. Table 8 shows only the costs of the Network Company.

Table 8. Empirical DSM costs related to commercial customers

DSM activities	DSM costs [Euro/kW]
Identifying bottle-neck:	7,4
Motivation and energy auditing:	34,3
Load profile analysis:	13,1
Evaluation:	5,2
Implementation:	13,8
<b>Total DSM costs:</b>	<b>73,9</b>

Up until recently, DSM actions have not been used as an alternative to grid reinforcement because of the uncertainty concerned with costs and time frame of implementation. Referred to the Figure 43, the studies regarding commercial customers in Oslo have experienced costs for the network company as shown in Table 8.

Taken into consideration the exposure-period of the grid reinforcements that can be achieved from DSM actions, the network company's cost regarding grid reinforcement in the particular area was estimated to approximately 110 Euro/kW (net present value of  $C_{\text{grid-reinforcement}}$ ). Compared to the actual DSM cost of today ( $C_{\text{DSM}}$ ) at approximately 74 Euro/kW, DSM actions were preferred to the planned grid reinforcement. All energy efficiency actions which were implemented were profitable to the customer. However, the cost-benefit incentive was not always the most vital incentive for the customer to accomplishing DSM actions.

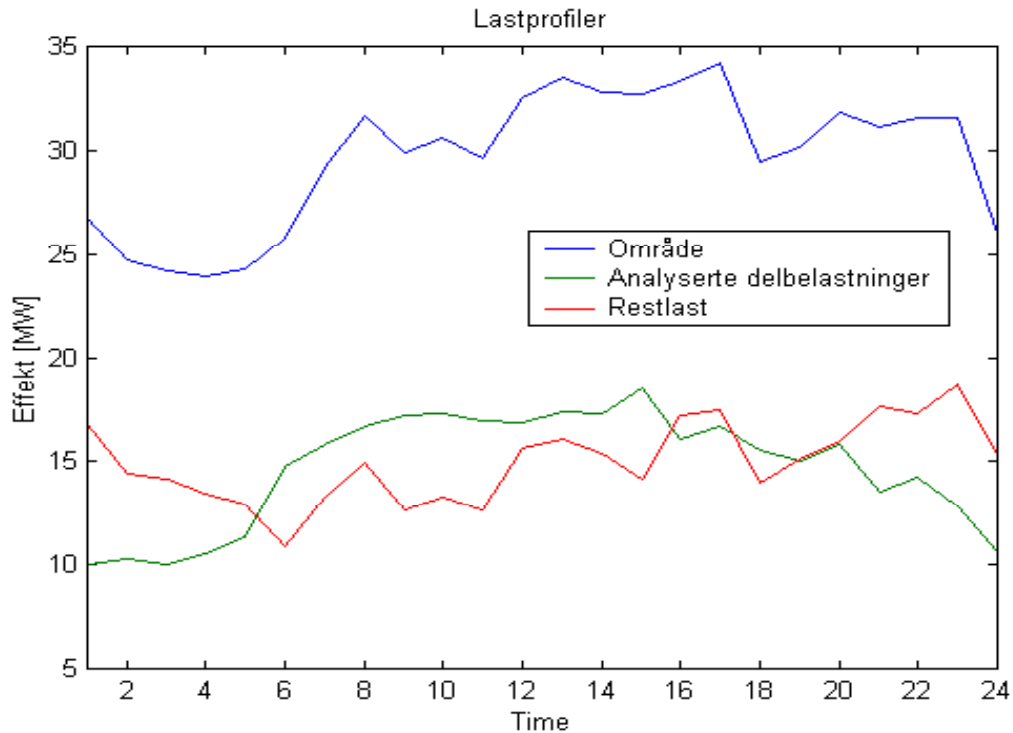

Figure 58. Maximum load profiles for one of the substation (nr 2) supplying the particular customers

In Figure 58 the load profile for one of the two transformer substations, representing the two actual bottlenecks, is shown for the maximum 24 hours. The blue curve shows the total area load profile, the green curve shows the profile for the selected customers, while the red curve shows the remaining load profile. The total of green and red curve equals the blue curve. The achieved peak load reduction of substation 2 from the implemented energy efficiency actions (among the 13 customers) was estimated to 4.0 MW without accumulation and 3.7MW with accumulation.

Table 9 shows the estimated peak load reduction and energy savings achieved from the implemented actions among the 13 commercial customers.

Table 9. *Key figures of energy savings and peak load reduction estimated for the 13 commercial customers*

Commercial customer	Year 1999: Cost (€)	Year 1999: Subsidies (€)	Peak load reduction kW	Energy saving kWh/year
A	98 110	8 698	35	129 650
B	22 823	2 644	14	87 100
C	1 850 427	217 329	3753	8 665 092
D	557 135	32 067	124	753 679
E	28 350	3 053	132	722 700
F	6 540	941	10	46 860
G	3 659	683	-	33 768
H	801 503	143 584	370	1 396 345
I	3 045 447	259 035	150	1 499 927
J	8 962	1 792	82	-
K	50 000	3 293	107	465 400
L	21 951	-	-	29 779
M	1 077 602	93 210	290	888 191
<b>Sum</b>	<b>7 572 509</b>	<b>766 328</b>	<b>5 067</b>	<b>14 718 491</b>

The estimated peak load reduction of 5.067 kW in Table 9 is not accumulated as regards the bottleneck problems in the two actual transformer substations.

The following model is a proposal for structuring of motivation and incentives, based on experience and results, accumulated within the study. The main objective was to systemise key factors, which are essential for definition of DSM-actions appropriate for a given customer and have therefore best possibility to be implemented. It is important to mention that the model relates to information and data, which are usually publicly available. It is therefore assumed that it is possible to work on Part A before or the same time as Part B. The proposed model includes two parts as it is shown on Figure 59.

### Part A

Organisation form is related to a composition of different factors and details, related to a given company implementing DSM. The model summarises previously mentioned difference in priorities between companies with a flat organisation (usually private companies) and companies with vertical structure (usually public institutions) related to investment and profitability of DSM.

Recommendations for implementation: Possible solution for companies with a flat structure is to emphasise initiatives with low risk and high profitability (even though they may require high initial investments). These companies require follow-up and intensive advisory services.

Companies with a vertical structure prefer solutions with low initial investment, but can accept high operation costs.

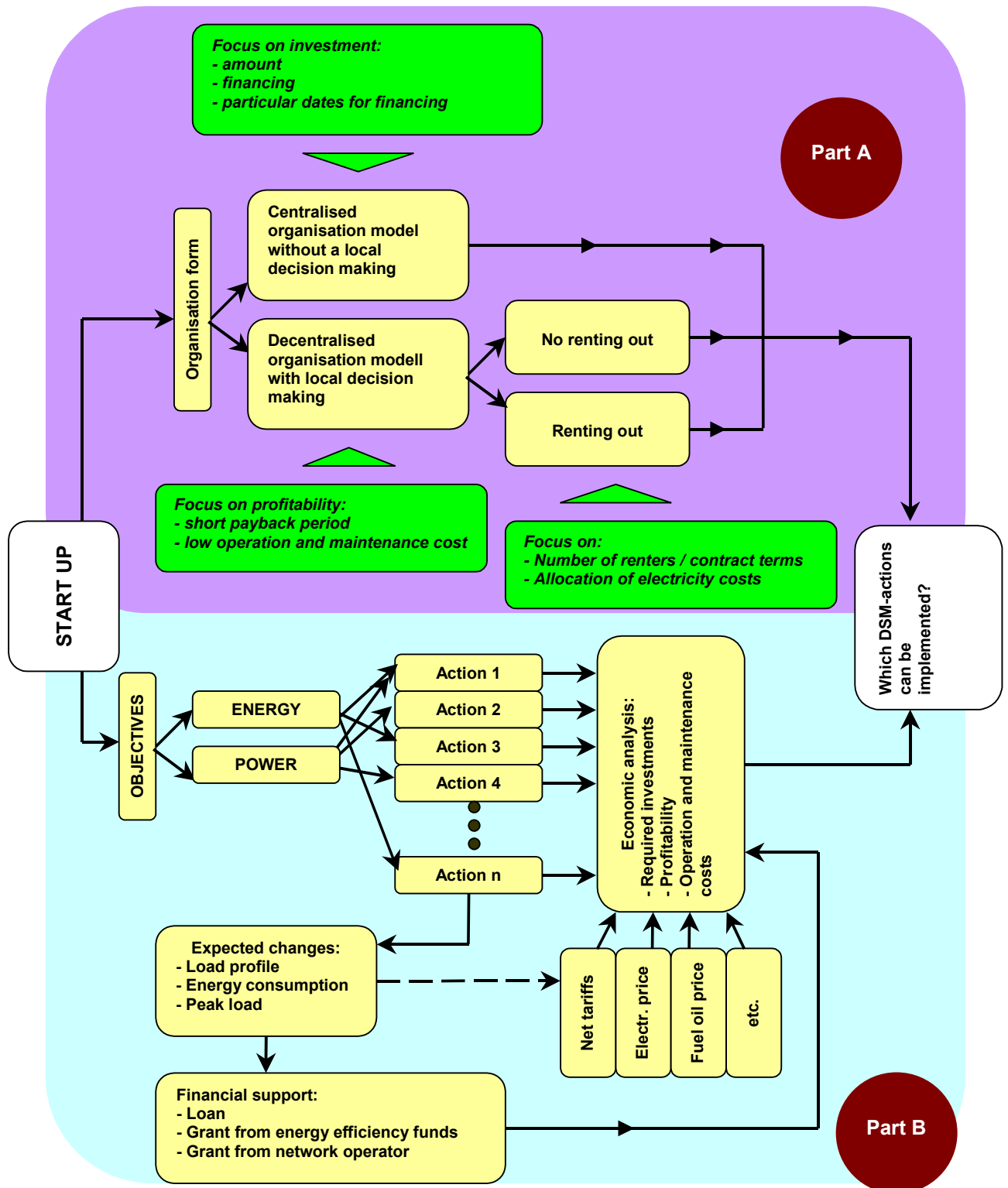

Figure 59. Motivation and incentive structure

Part B

Part B is related to analysis of existing potential for reduction of electricity- and power consumption, which can be released via DSM.

Objectives: Development of proposals for DSM should start from definition of concrete objectives in a given network area, including required reduction of peak capacity or/and alteration of load profiles.

Actions: Definition of actions, which can be implemented, starts with a preliminary technical evaluation of the potential for load management and energy efficiency existing in a given company.

Economic analysis: The analysis of the proposed actions includes investment analysis, profitability, operation and maintenance costs. The analysis also considers support schemes, based on expected consequences from actions. Development of several scenarios based, for example on different electricity contracts and network tariffs, may improve the evaluation process.

Choice of the most appropriate actions: Comparative analysis of the proposed actions, together with factors related to company's factors and priorities, allow choosing the set of most appropriate actions.

## **5.7 Conclusions and evaluation of results**

In several cases, DSM actions can be proved to be profitable compared to conventional grid reinforcements. But to be profitable to the network company it must be ensured that the actual DSM actions serve as remedial actions concerning capacity problems in the distribution systems. To achieve this, the means which are used have to comply with the incentives and goals among both the Network Company and the customer. All experience shows that customers have to be strongly motivated to implement energy efficient actions, in spite of the fact that the customers can save money for themselves.

Through comprehensive studies in Oslo a methodology for implementing DSM actions as an alternative to grid reinforcements has been developed. A pilot study in a random grid area in Oslo, shows a general potential for energy saving and peak load reduction of 10-15%. This potential is related to a wide type of measures, among them installation of new equipment, replacement of electrical energy carriers, renovation of buildings and installation of smart house solution. There is a similar potential among residential customers related to electrical heating and electric boilers. In difference to Central Europe, Norwegian households are mainly dependent on electrical heating. The time horizon for realizing DSM actions is empirically 3-4 years for commercial customers and 1-2 years for residential customers.

Implementation of DSM actions depends on several motivation key factors, such as "ownership vs. rent of premises", "cost allocation", "contact persons and decision-making process", as well as financing solution for the DSM actions. All energy efficiency actions which were implemented in the pilot studies were profitable to the customer. However, the cost-benefit incentive was not always the most vital incentive for the customer to accomplishing DSM actions. The network tariff which makes about 20-40% of the total electricity cost, affects the majority of the motivation key factors. To what extent DSM actions is accomplished in certain grid area, as well as the time horizon for implementation, depends on key motivation factors and how these are being exploited.

## **6 Norwegian Pilot 2: New technology for controlling power loads in Oslo**

### **6.1 Introduction**

The Norwegian project “New technology for Controlling of Power load in Oslo” is by the Norwegian sponsors of the EFFLOCOM project defined as an EFFLOCOM pilot project. This means that the main results and general conclusions from this project are available for the EFFLOCOM project group.

On the basis of results from the pilot project “Implementation of DSM in Oslo”, the grid owner of the Oslo region, Viken Nett<sup>4</sup> (also referred to as the Network Company), decided to carry out the project “New technology for Controlling of Power load in Oslo”.

The main approach in this project is to achieve remote control of design load for the grid capacity. Finding the method and the network tariff to initiate such load control, one has found an important key to postpone grid reinforcement. The results from this pilot will also make the basis for the Network Company to participate in the balancing market of the system operator.

### **6.2 Objectives and summary of project facts**

The main objective of this pilot is to initiate remote control of minimum 2 MW power load among various categories of commercial customers. The power load is to be controlled in a limited time period and shall not be ordinary interruptible power loads such as electric boiler with back up systems. The power load that is to be controlled shall be defined as uninterruptible consumption according to the existing Network tariff or in other words defined as design load of the grid capacity. The grid owner in the project will initiate implementation of necessary actions among the commercial customers through offering new network tariffs. Necessary actions will be implementation of new technology for smart house and building automation or other solutions for remote control of single power loads. The project will also gain knowledge concerning “what makes the customer carry out the necessary actions?”

---

<sup>4</sup> Viken Nett was renamed to Hafslund Nett the 20<sup>th</sup> of April 2004. In this report Viken Nett is referred to as Viken, the Network Company or the grid owner.

Table 10. Overview of basic data of the Norwegian pilot “Controlling power loads in Oslo”

<b>Summary overview – Norwegian - pilot CPO</b>	
<i>Project title:</i>	Controlling power loads in Oslo (CPO)
<i>Project period :</i>	2000-2004
<i>Economic size :</i>	62 Thousand €
<i>Sponsors :</i>	Viken Nett ltd. (renamed to Hafslund Nett the 20 <sup>th</sup> of April)
<i>Executive :</i>	E-CO Tech ltd., Viken Nett ltd.
<i>Motivation of the sponsors :</i>	Remote control of power load. Unloading bottlenecks in the grid and bidding in the balancing market
<i>Project angel :</i>	Analysing the potential for load control in limited time period, implementation of actions, customer motivation
<i>Number and category of customers involved :</i>	14 commercial customers
<i>Method of attack for involving the customers:</i>	Offering new tariff for interruption of load in limited time periods. The customer themselves has to pay for the energy efficiency action.
<i>Examples of energy efficiency actions, smart house :</i>	Controlling water pumps, disconnecting electric boiler without reserve, downward adjustment of loads etc.
<i>Direct communication to the customer? (Yes/No) :</i>	Yes, including two-way communication.
<i>If yes, technology for communication :</i>	GSM, wireless radio communication, PSTN, GPRS
<i>Test related to web based energy efficiency info :</i>	The network company controls the power load via a web based software system called LeKey.

### 6.3 Project angle and methodology

Compared to the methodology used in pilot 1, “Implementation of DSM in Oslo”, this pilot only focuses on technical solution for load control and the means needed to make the customer allow the Network Company to remote control different loads. The project has selected a random group of commercial customers with historical peak load above 800kW each and with location in the eastern part of Oslo. The focus in this project is to find solutions of remote control of power load, which do not interfere with the customers’ activity. There are several challenges to face because the activities among the customers vary from furniture sale, copper melting, and water supply, engineering work to operating an outdoor skating rink. When finding smart-house solutions to control different power loads which hardly ever have been controlled or interrupted before, the methodology for convincing the customer is

vitaly important. In most occasions it is the customer himself who knows best the vulnerability of the power loads and most customers will be more or less sceptical of any changes of the normal activity. Therefore, the project has focused on the methodology of presentation of the new network tariff, as well as designing a tariff that makes the customers invest in the necessary smart-house solutions for load control themselves.

When designing a new network tariff the customers are given the best incentives for letting the Network Company remotely control power loads. It is also important that the new tariff simultaneously fits into the existing tariff structure of the Network Company. This postulation is vitaly important if the tariff that is produced by the project shall be included in the standard Network tariffs of Viken Nett. Today the tariff structure of the Network Company, Viken Nett, can be illustrated in the following simplified Figure 60.

**Tariff structure 2002-2004:**

class II	class I	class IV	class V	<u>ordinary</u>	Cost- benefit
Momentary Interruption, unlimited durability	Interruption with alert one hour or more, unlimited durability	Momentary Interruption, limited time period	Interruption with alert one hour, limited time period	Uninterruptible consumption	→

*Figure 60. Tariff structure of Viken Nett*

As shown in Figure 60, letting the Network Company control one kW in limited time period is less profitable than letting the Network Company control one kW with unlimited durability. At the same time momentary control is more profitable than control with alert. Additionally, the level of connection in the distribution network will reflect the cost-benefit category of the network tariff.

Another motivation for the Network Company for establishing a new tariff for load control in limited time period is to prepare for making additional agreements with the same customers to participate in the Regulatory Capacity Option Market.

The regulatory (or balancing) market is a tool that the system operator in Norway (Statnett SF) uses to maintain a stable frequency and a continuous balance between production and consumption of power in the country. Statnett receives quotes from major producers or consumers that are willing to alter their power generation and/or consumption plans at short notice. In addition to this the regulatory market also includes a national option market for fast-operating reserves, called Regulatory Capacity Option Market (RCOM). In this market Statnett invites participants from both producers and large consumers to enter contracts where they guarantee that they can supply Statnett with a specific volume of power reserves in the balancing market for a given period of time. This market enables Statnett to maintain a balance between production and consumption even when the power balance is tight. The smallest volume that can be quoted is 25 MW within the specified grid area and time period.

The learned experience from this project will be used by Viken Nett to make agreements with customers for bidding in the option market (RCOM). To participate in the balancing market,

called RCOM, additional agreements to the tariff have to be made with the customers. All customers have to be made familiar with their participation in RCOM.

The following flow chart shows an overview of the activity in the project from start-up until ongoing activity of today (spring 2004).

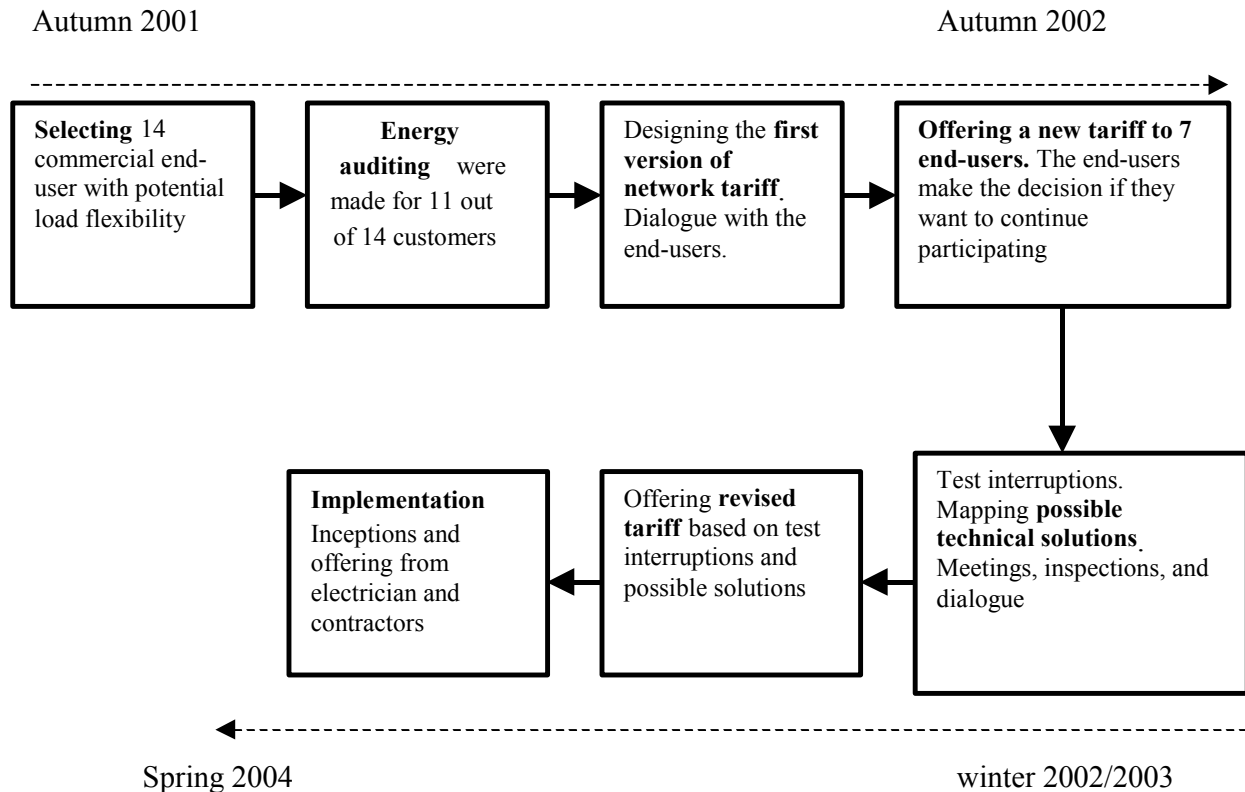

Figure 61. Flow chart showing the project activities

As it appears from Figure 61 a random group of 14 commercial customers were selected during the autumn of 2001. Each of these customers had an historical peak load above 800kW in the year 2000 and they were all located in the eastern part of Oslo. The 14 customers were offered a free energy auditing. 11 out of these customers chose to participate further in the project by letting the project complete an energy auditing. On the basis of the documented potential for load control in limited time period and on the basis of a dialogue with the customers, a proposal for network tariff (first version) was made. 7 out of the 11 customers received an offer of new tariff. Among the 7 customers test interruptions were accomplished, as well as further inspections meetings to map possible technical solutions. Due to scepticism among the customer for investing in a remote load control solution based on a brand new pilot tariff, the two most positive customers were chosen to be closely followed-up. The project decided to wait with following-up the other five customers in anticipation of the experience made with the two most interested. The development of participation of customers in the project is shown in the following Figure 62.

Start-up	Analysis		Tariff design	Implement
2001	2002		2003	2004
14	11	7	7	2

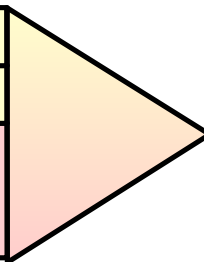

Figure 62. Development of number of participants

During the year 2004 the project will introduce new meetings and inspections with the five remaining customers that have rejected the offered pilot tariff and, therefore, not have implemented recommended solutions. The project will try to discover possible adjustments in the new tariff that might trig implementation of remote load control.

#### **6.4 Pilot test - commercial customers: Implementation of remote control of different loads in limited time periods**

A considerable potential for controllable power load is documented among the 7 out of 14 customers. These 7 customers have a total maximum peak load of 18.1MW and are offered a new pilot tariff from the Network Company. The potential for controllable load among the 7 customers is estimated at 8.8 MW or 49% referred to maximum peak load. The new pilot tariff shall give the customers cost-benefit incentive for investing in load control solutions, as well as giving incentive for letting the Network Company remote control the particular loads in limited time periods. Several approaches appears when it comes to realising such a tariff:

- What is the possible flexibility when interrupting different kinds of loads, such as water pumps, air conditioning aggregate, compressor cooler, electric boiler without back-up system and small melting furnaces? How vulnerable are these kinds of loads? Maybe the particular load cannot be switched off due to the vulnerability, but on the other hand the load might be adjusted downward.
- What kind of limitations and barriers for load control do different customers with different activity have? These could be barriers or limitations related to durability and frequency of interruption related to the customers activity, time of rest between interruptions, or maybe there are barriers connected to implementation of new technology due to the customer activity to day.

When it comes to permitting the network company to remote control power load, it might be difficult to distinguish between a psychological barrier and the actual limitation of the controllable load. It appears a natural scepticism when the network company knocks on the customers' door and ask if the customer is willing to make an agreement on remote control of the power loads that run his/her main activity. Even if this means that the customer will enter into a profitable network tariff contract, he or she have to make sure that any remote control by the network company does not interfere with the activity. However, if the customer allows the remote control to involve a reduction or stop of the activity, the tariff agreement must make this interference more profitable than ordinary activity.

### ***6.4.1 Description of solution and technology from the Network Company point of view***

The grid owner Viken Nett has established a new solution for remote control of power load. Compared to the traditional solution based on phone communication, this new solution is based on radio communication and Internet application software. Viken Nett is the first grid owner in Norway using this load control technology and several other grid owners in Norway are considering or have started implementing similar solutions. The new load control system is adjusted for demand side bidding in the Regulatory Capacity Option Market. This market requires immediate load control with no need for alerting the customer before interruption. Today Viken Nett controls only loads with backup systems, such as electric boilers. In this project Viken Nett wish to map and test the potential for remote control of other power load by exploiting the loads slow operation. The learned experience from this project will be used by Viken Nett to design a new standard tariff and to make agreements with customers for bidding in the Regulatory Capacity Option Market.

#### **A solution for remote load control based on Internet called LeKey**

The software solution for load control, called LeKey, is developed by Elink AS and Viken Nett and is employed in the regulatory market today by Viken and other Norwegian network companies. Using LeKey one can control power loads from Internet. The Figure 63 gives an overview of possibilities for the network company when using LeKey for remote load control.

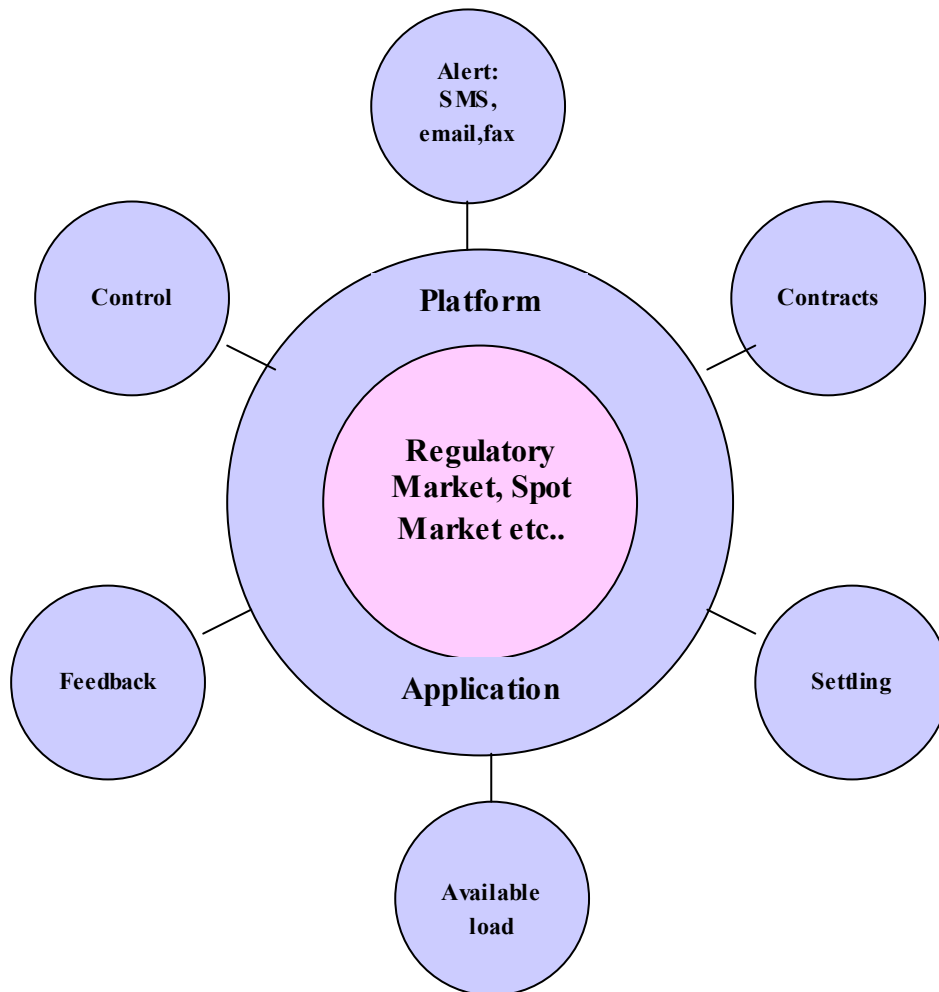

Figure 63. Illustration of possibilities using LeKey software solution for load control

Efficient SMS communication to the terminals results in high reliability. Alert before remotely interruption or control, can be directed by SMS or email. Because the solution is based on Internet, remote control can be fulfilled from anywhere with access to Internet. This makes the administration of load control flexible for the Network Company.

The alert messages that are being sent from the LeKey system can be configured in advance with desirable name and remarks. In addition to email or sms, alert can also be given by fax. Fax messages will be sent from Internet and will be administrated from the LeKey software application of Elink. Both two-way and direct communication can be used to control power loads. The best communication solution for the Network Company or for the particular group of customers will appear from a cost-benefit analysis of the Network Company. The following Figure 64 illustrates the solution for remote load control.

The communication is wireless and nation-wide and does not assume any investments in infrastructure. The LeKey system can both control single-loads and groups of loads. Using two-way communication, the system will produce feed back messages or receipt of process status. On the Internet web page the network company can verify if the particular load is available for interruption or not. Developing the LeKey solution, Elink has also agreed on a co-operation agreement with Enermet. Elink deliver software for load control and Enermet deliver the SMS terminal D-100.

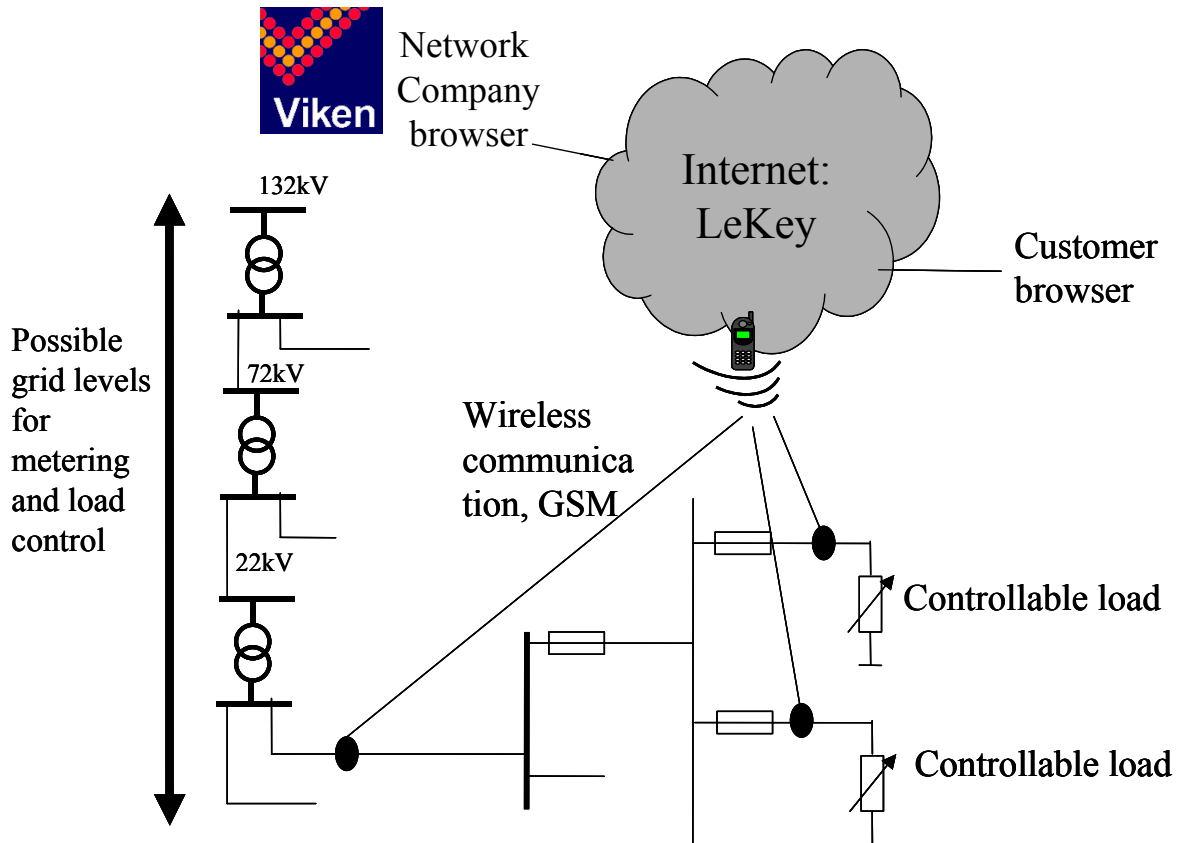

Figure 64. Load control solution of Viken Nett based on Internet and wireless radio communication

#### 6.4.2 Description of solution and technology for the customers

The purpose of offering reduced tariffs (pilot tariffs) to seven commercial customers was to make them allow the network company to remotely control power load in limited time period (maximum 3 hours). The intention of the technical solutions for remote control was to ensure no impacts on the customers' activity. In the following section each of the seven customers are briefly described.

##### Customer No. 1: The City of Oslo water supplier – "Water pumping plant"

The water pumping plant supplies the majority of the inhabitants in Oslo with drinking water. The plant ensures water purifying and water pumping ensuring that the consumers receive water with high quality and correct water pressure. Eight high-pressure pumps of 440kW are installed and the potential maximum peak load is 3,5 MW. In normal operating mode 2 or 3 pumps are continuously running. In periods of larger water consumption four pumps are running. This usually occurs for instance in the watering season during the summer. Otherwise, four or five pumps serve as a backup. All consumption of the water pumping plant, included the high-pressure pumps, have low voltage supply, partly 230V and partly 400V.

In the following Table 11 an overview of vital information and results is shown for the water pumping plant.

Table 11. *Essential data and results of customer No.1, Water pumping station*

<b>Water pumping plant</b>			
<b>Information category</b>	<b>Size/volume</b>	<b>Unit</b>	<b>Comment</b>
Building floor space:	28.907	m <sup>2</sup>	28.000m <sup>2</sup> involves underground reservoir and pumping plant
Number of buildings:	3		Including underground building space
Any other description:	75.000	m <sup>3</sup>	Underground reservoir
Service/delivery:			Main water supply of Oslo
Energy consumption (of the relevant meter):	15.483.420	kWh/y	Related to the year 2000
Maximum peak load (of the relevant meter):	2.855	kW	Related to the year 2000
Estimated controllable load:	1.500	kW	Related to several tests. Assumed maximum available load while interrupting.
Energy consumption of controllable load:	8.250.000	KWh/y	
Spring of 2004: Status of implementation process			Offers from two electrician companies are received and the implementation will be completed within the spring of 2004.
Expected cost of establishing load control:	33.207	€	Based on offers from two electrician companies
Expected reduction of operating costs:	9.474	€/y	Due to new reconstruction plans of the pumping plant, the original expected cost reduction of 30.488 €/y was reduced to 9.474€/y
Payback period:	4	years	According to the customers' wish: Analysis period 20 years. Interest 6%
Possible network tariff			Low voltage tariff, due to low voltage supply. Momentary interruption.

In the water pumping plant there will be implemented a function of interruption of high-pressure pumps remotely controlled by the Network Company, Viken Nett. The interruption of pumps will have the following postulation:

- Two interruptions a day require a maximum duration of 2 hours with 6 hours rest between interruptions
- One interruption a day require a maximum duration of 3 hours

According to the size of the water reservoir, the water level does not fall considerably due to normal water consumption during these two alternatives of load control. This conclusion is based on several test interruptions. On the other hand during exception situations such as leakage, flood and city fire, the pumping station some times has to run 6 high-pressure pumps. Interruption of water pumps in these situations is not possible. Such critical or exception situations only occur once every 10 or 20 years.

To establish a remote control of the water pumps, it is required that the pumps are supplied from a separate circuit with a separate meter. This will involve an extensive reconstruction of the electrical system with considerable electrician costs. However, another and more reasonable solution of metering was suggested as shown as solution a) in the Figure 65

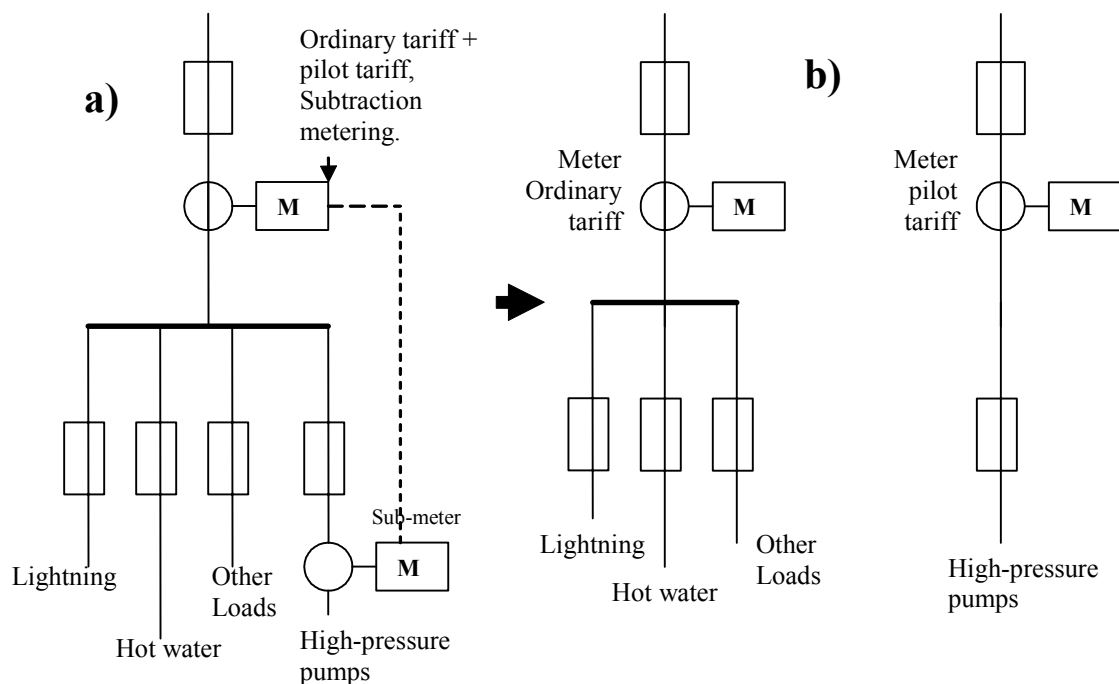

below.

Figure 65. Simplified sketch – metering of controllable and not controllable load

Empirical, solution a) that is based on subtraction metering, involves about 20% (average) of the costs compared to solution b). The project have discussed advantage and disadvantage attended with solution b), and has concluded that this solution goes against the directions of the Network Company and that this solution involves too many drawback attended to

processing subtraction data and too many possibilities for error sources. Thus, the solution b) shown in Figure 65 makes the postulation for establishing load control.

The signal from the Network Company of activating load control will be transmitted through the meter terminal equipment. An automatic procedure for a successive interruption of each high-pressure pump will be effectuated. The gradual downward adjustment is cardinal to avoid any damages of the high-pressure pumps and the appurtenant control units. The interruption of all pumps will be completed within 15 minutes after receiving the disconnection signal from Viken Nett.

### **Customer No. 2: Furniture dealer**

This furniture dealer is located in the eastern part of Oslo and is a part of a larger chain store in Scandinavia, with locations in the larger cities. The furniture dealer contains a floor space of 21.000m<sup>2</sup> within one building. Two electrical boilers of 430kW and 774kW supply hot water to 6 air conditioning aggregates that serve offices, shop area, a restaurant and a kitchen. The pumps of the air-conditioning plant can produce 50.000m<sup>3</sup> per hour and are furnished with a circulation pump and a heat recuperator. The supply voltage of the electric installation is 400 voltage. In the following Table 12 an overview of vital information and results is shown for the furniture dealer.

Table 12. *Essential data and results of customer No.2, furniture dealer*

<b>Furniture dealer</b>			
<b>Information category</b>	<b>Size/volume</b>	<b>Unit</b>	<b>Comment</b>
Building floor space:	21.000	m <sup>2</sup>	
Number of buildings:	1		
Service/delivery:			Furniture dealer in Oslo.
Energy consumption (of the relevant meter):	3.325.000	kWh/y	Related to the year 2000.
Maximum peak load (of the relevant meter):	1.360	kW	Related to the year 2000
Estimated controllable load:	1.000	kW	Related to estimation by the customer. Assumed maximum available load while interrupting.
Energy consumption of controllable load:	3.325.000	KWh/y	
Spring of 2004: Status of implementation process			Offers from three electrician companies are received and the implementation will be completed within the spring of 2004.
Expected cost of establishing load control:	24.390	€	Based on offer from three electrical contractors. Also included hours of effort contributed by the customer himself
Expected reduction of operating costs:	24.390	€/y	
Payback period:	1	year	According to the customer's wish: Analysis period 5 years. Interest 7%
Possible network tariff			Low voltage tariff, due to low voltage supply. Momentary interruption.

The furniture dealer will implement a function of remote interruption of the two electric boilers and all electric installation of the air conditioning plant. The Network Company, Viken Nett, will remotely control these loads momentarily according to the following postulation:

- Two interruptions (downward adjustments) a day with maximum duration of 3 hours with 5 hours rests between each interruption.

The furniture dealer has today a building automation system, TAC, which controls all loads in the building. This automatic system will serve the downward adjustment of the electric boilers and 6 of the air conditioning plants. Simultaneously, the automation system will ensure that the air-conditioning aggregate supplying the restaurant runs normally.

Due to wide and open premises in the shop area, the air quality will not be reduced considerable as a result of the three hours interruption of the 6 air conditioning aggregates. The hot water consumption is not considerable high and the hot water temperature will not be affected by the three hours downward adjustment of the electric boilers. These conclusions are made by the customer based on tests.

To establish a remote control of the electric boiler and the air conditioning plant, it is required that these loads are supplied from a separate circuit with a separate meter. This is a similar solution as shown sketch b) in Figure 65. The electric installation of the furniture dealer has to be reconstructed to a separate circuit supplying the controllable loads, two electric boilers and six air-conditioning aggregates. The signal from the Network Company of activating load control will be transmitted through the terminal equipment metering the controllable loads. The downward adjustment of the two electric boilers and the six air-conditioning aggregates will be completed by the building automation system within 15 minutes after receiving the disconnection signal from Viken Nett.

### **Customer No. 3: Computer Central**

The Computer Central is a renter in a building owned by a company that owns and operates several buildings in Oslo. The building, which is located in Groruddalen in the eastern part of Oslo, contains a floor space of about 23.000m<sup>2</sup> with mainly offices and storerooms housing PC and Servers. The Computer Central rents about 10% of the floor space, but makes the largest electricity consumer in the building. More detailed information about the Computer Central is given in the appendix.

In the following Table 13 an overview of vital information and results is shown for Computer Central.

Table 13. *Essential data and results of customer No.3, Computer Central*

<b>Computer Central</b>			
<b>Information category</b>	<b>Size/volume</b>	<b>Unit</b>	<b>Comment</b>
Building floor space:	23.000	m <sup>2</sup>	The computer central is the main renter
Number of buildings:	1		
Service/delivery:			Housing and operating computers
Energy consumption (of the relevant meter):	3.024.864	kWh/y	Related to the year 2002
Maximum peak load (of the relevant meter):	382 - 1.600	kW	Related to the year 2002
Estimated controllable load:	382 - 1.600	kW	Related to several tests. Assumed available load while interrupting.
Energy consumption of controllable load:	3.024.864 - ?	KWh/y	
Spring of 2004: Status of implementation process			Because the pilot tariff only does reward interruption of load and does not reward supply of power load (from a diesel generator), The computer central can not find the "profit motivation" of implementation.
Expected reduction of op. costs:	9.682	€/y	
Possible network tariff			Low voltage tariff, due to low voltage supply. Momentary interruption.

The Computer Central operates a computer-housing central where customers are renting rooms for PC and Servers. Due to the PCs which are connected to the Internet and which contains and operate important information of other companies, the Computer Central is vulnerable for power failure of any kind. Therefore, the computer-housing central is supplied from an electric circuit separated from the rest of the electric installation of the building. If any failure of the power supply occurs, an UPS (Uninterruptible Power Supply) momentarily will take over the power supply. If the duration of the power failure remains for more than 15 minutes, a diesel generator will be started and take over for the UPS battery. The diesel generator back-up system will maintain the power supply until the power failure in the network has been corrected by the Network Company (grid owner) and a normal operation of the network is established. The supply voltage of the electric installation is 400 voltages.

Three UPS batteries with 480 kVA (Tudor-batteries) are installed. Maximum capacity of the UPS system is 960kW. Two diesel generators of 3,2MVA and 2,2MVA are installed. This backup system is able to supply the Computer Central with maximum 3,2MW. To ensure the safety of the backup system, the operation of the diesel generators are routine tested for four hours each month. Once a year, a “black out” test is done. In these tests the power control switch of the main supply busbar is turned off to verify if the UPS and the diesel generator start up as required.

The depression of the IT and data industry during the years 2002-2003, have been discernible for the Computer Central. In 2003 only 10% of the computer-housing central was used due to the lack of customers. Therefore, the average power load consumption today only represents 0,4MW out of the capacity of 3,2MW. Due to low profit (of today) from reward of 400kW in the pilot tariff from Viken and due to the cost of 0,21 €/kWh for running the diesel generator, the Computer Central can not see the necessary motivation to invest in a load control solution.

**Customer No. 4: Outdoor skating rink**

In the following Table 14 an overview of vital information and results is shown for the sport centre.

Table 14. *Essential data and results of customer No.4, Sport centre*

<b>Sport centre - skating rink</b>			
<b>Information category</b>	<b>Size/volume</b>	<b>Unit</b>	<b>Comment</b>
Space of building floor/base:	30.000	m <sup>2</sup>	Involves the skating rink
Number of buildings:	2		
Service/delivery:			Skating rink, national and international arrangements
Energy consumption (of the relevant meter):	2.479.200	kWh/y	Average of the period 1998-2000. Corrected according to degree days
Maximum peak load (of the relevant meter):	1.717	kW	Related to the year 2000
Estimated controllable load:	1.000	kW	Related to several tests. Assumed maximum available load while interrupting.
Energy consumption of controllable load:	1.500.000	KWh/y	
Spring of 2004: Status of implementation process:			Due to high investment costs and present investment plans, implementation is not realised so far.
Expected cost of establishing load control:	5.854	€	This cost is based on solution a) in Figure 65 and is therefore a too small amount. The cost is based on offer from one electrician. A new cost-evaluation (offer) has to be made.
Expected reduction of operating costs:	21.341	€/y	
Possible network tariff			Low voltage tariff, due to low voltage supply. Interruptions with one hour alert.

The sport centre including an outdoor skating rink was built in 1967. In addition to the ice rink, the sports installations consist of an outbuilding and a building with wardrobes and a restaurant. The total area of the ground is about 30.000m<sup>2</sup>, of which 1300m<sup>2</sup> is heated floor space. The consumption of energy and power load is mainly related to the cooling plant of the skating rink. The season for skating is limited to the middle of October until the beginning of March each year. The cooling compressors only operate when the outdoor temperature is

between +5 °C and –3 °C. Therefore, the limitation of load control is considerable. However, bottleneck problems in the distribution network of Viken Nett might occur also during this actual temperature interval. Therefore, Viken Nett decided to offer the sport centre the pilot tariff. The skating rink has installed 5 cooling compressors with 380 Voltage supply. During normal operation when the weather is mild, the compressors consume about 1200kW. Several national and international arrangements are carried out at this skating rink, and, therefore, the quality of the ice has first priority. A test of possible interruptions with measuring of air- and surface- temperature where completed in the project.

*Table 15. Test measurement of 3 hours interruption of 5 cooling compressors of the skating rink*

<b>Time of measuring</b>	<b>Temperature of ice-surface [°C]</b>	<b>Air temperature [°C]</b>
Before interruption	- 6,8	+ 4,0
Immediately after interruption	- 5,1	+ 4,2
5 operating hours after interruption	- 6,0	+ 6,2

The test measurement of complete stop of all five cooling compressors, as shown in Table 15 confirmed that such a power load interruption (control) for 3 hours does not interfere with the maintenance of the ice quality. The only remaining barriers that could prevent the realising of load control are the designing of the technical solution for remote control and how the cost-benefit picture appears to the sports centre due to the offered network tariff. Due to the uncertainty of the investment using solution b) shown in Figure 65, the sport centre has decided to wait with making a final decision of implementing a possible load control solution.

**Customer No. 5: Small industry plant**

In the following Table 16 an overview of vital information and results is shown for the Small Industry plant.

Table 16. *Essential data and results of customer No.5, Small Industry plant*

<b>Small industry plant</b>			
<b>Information category</b>	<b>Size/volume</b>	<b>Unit</b>	<b>Comment</b>
Space of building floor/base:	6.600	m <sup>2</sup>	Includes the production premises
Service/delivery:			Producing additive copper oxide product that other companies use for production of paint and vegetable eradicants
Energy consumption (of the relevant meter):	3.805.600	kWh/y	Related to the year 2000
Maximum peak load (of the relevant meter):	2.015	kW	Related to the year 2000
Estimated controllable load:	1.500	kW	Related to several tests/daily operations. Assumed maximum available load while interrupting.
Energy consumption of controllable load:	3.805.600	KWh/y	
Spring of 2004: Status of implementation process			Due to customer discontent of the pilot tariff offer, the implementation process has been temporary stopped.
Expected cost of establishing load control:			The cost of establishing a load control solution has not been estimated.
Expected reduction of operating costs:	15.244	€/y	
Possible network tariff			High voltage tariff, due to high voltage supply. Interruptions with one hour alert.

The small industry plant is a chemical plant producing copper oxide using scrap copper and crude copper. The plant uses three melting furnaces for melting the copper before further processing of the material. The copper oxide is being refined to additive product that other companies use for production of paint and vegetable eradicants. The majority of consumed energy and power load is related to melting furnaces and reactor plant. The agglomeration of buildings consists of 6.600m<sup>2</sup> heated floor space and is divided in five sections; melting furnaces, reactor plant oxide section, EXLT section and administration. The buildings are constructed in 1964 with some modernisation in 1988. So far in the project, only the melting furnaces have been evaluated for a possible load control solution.

The small industry plant is monitoring all processes and activity 24 hours a day, 7 days a week. The control room from where the decision is made whether an interruption of the melting furnaces can be done or not, will be manned continuously. The plant can enter into a tariff-contract of load control with the Network Company assumed that the interruption is done manually by the operating staff of the industry plant and with one hour of alert before interruption. On the condition that the melting furnaces are not running in a critical operating mode, the operating staff of the industry plant can downward adjust the melting furnaces until a minimum-operating load. The industry plant need one hour to empty the furnaces before the downward adjustment is effectuated. Because the pilot tariff that is offered in the project is not suitable to the flexibility that the melting furnaces represent, the industry plant has decided that they will not make any agreement before Viken offer them an alternative Network tariff. In the following Figure 66 the flexibility of the melting furnaces is illustrated.

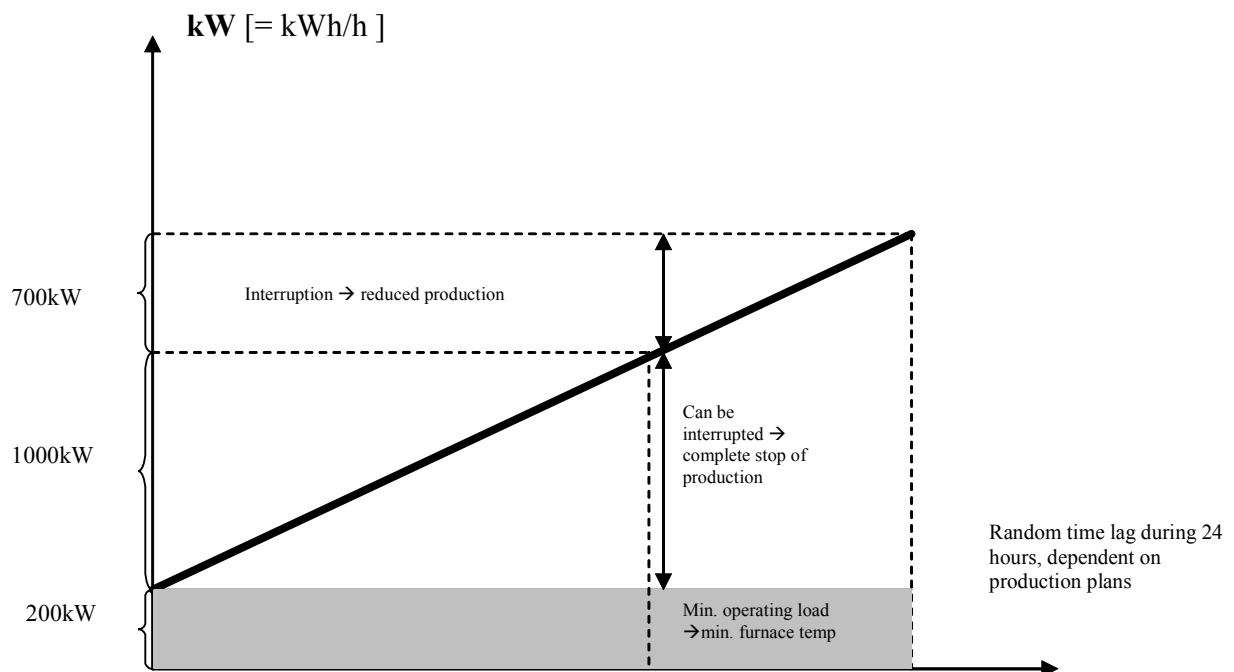

Figure 66. Illustration of possible flexibility of the melting furnaces of the small industry plant

**Customer No. 6: Engineering workshop**

In the following Table 17 an overview of vital information and results is shown for the Small Industry plant.

Table 17. *Essential data and results of customer No.6, Engineering Workshop*

<b>Engineering workshop</b>			
<b>Information category</b>	<b>Size/volume</b>	<b>Unit</b>	<b>Comment</b>
Space of building floor/base:	50.000	m <sup>2</sup>	
Service/delivery:			Serves the Norwegian State Railways with engineering workshop
Energy consumption (of the relevant meter):	7.871.170	kWh/y	Related to the year 2000
Maximum peak load (of the relevant meter):	1.850	kW	Related to the year 2000
Estimated controllable load:	800	kW	No final estimation is made.
Energy consumption of controllable load:	2.400.000	KWh/y	No final estimation is made.
Spring of 2004: Status of implementation process			Due to the plans of installing a building automation system, the implementation process has been postponed.
Expected cost of establishing load control:			The cost of establishing a load control solution has not been estimated.
Expected reduction of operating costs:	20.122	€/y	
Possible network tariff			Low voltage tariff, due to low voltage supply.

The engineering workshop is located in the eastern part of Oslo and is owned by the Norwegian State Railways. The engineering workshop was built in several stages; in the decades of 1920, 1940 and 1960. During the last year's comprehensive rehabilitation have been going on. The engineering workshop consists of several buildings and the heated floor space makes about 50.000m<sup>2</sup>. The electrical installations are constructed step by step in the different building stages. This has resulted in a complex electrical distribution network supplying the controllable loads. The controllable loads are many, but relatively small and differ from 15 kW to 150 kW. Typical controllable loads are different motors, ventilation, heater batteries, water heater, fans and ventilators, as well as rail heaters. The supply voltage of the electric installations is reconstructed from 230 voltages to 400 voltages in the year of 2000.

Due to the complexity of the distribution network of the engineering workshop, it is difficult to establish interruption of particular loads without disturbing a large part of the other activity of the engineering workshop. In the present old electric installation there are small room for load control installation. The engineering workshop is planning to install a building automation system. This will probably involve replacement of old installations and reconstruction of parts of the distribution network. In addition to this the building automation system will make it possible to easily realise remote control of a particular group of loads. Due to this plan the implementation process has been temporary postponed.

### Customer No. 7: Public Swimming Pool

In the following Table 18 an overview of vital information and results is shown for the public swimming pool.

Table 18. *Essential data and results of customer No.7, Public Swimming Pool*

Public swimming Pool			
Information category	Size/volume	Unit	Comment
Building floor space:	10.260	m <sup>2</sup>	28.000m <sup>2</sup> involves underground reservoir and pumping plant
Number of buildings:	1		
Any other description:	4.000	m <sup>3</sup>	Swimming pool volume
Service/delivery:			Public swimming pool of Oslo
Energy consumption (of the relevant meter):	4.500.000	kWh/y	Related to the year 2000
Maximum peak load (of the relevant meter):	1.775	kW	Related to the year 2000
Estimated controllable load:	1.000	kW	
Energy consumption of controllable load:	4.500.000	KWh/y	
Spring of 2004: Status of implementation process			Due to the plans of installing heating pumps, the implementation process has been postponed.
Expected reduction of operating costs:	25.671	€/y	
Possible network tariff			High voltage tariff, due to high voltage supply. Momentary interruption.

The public swimming pool was established in 1975. Total heated floor space in the building included all floors is 10.260m<sup>2</sup>. Additional, the swimming pool has a volume of 4000m<sup>3</sup>. The

entire building, included the swimming pool is heated from a central heating system supplied from two electric boilers, both with 3,0MW capacity load. To verify the possibility of interrupting the electric boilers without any influence of the pool temperature or any influence on the temperature of the shower water, two interruption tests were completed. During the tests the outdoor temperatures were  $-1^{\circ}\text{C}$  and  $-3^{\circ}\text{C}$ . A three hours interruption resulted in no influence of the pool temperature, but the temperature of the shower water was reduced with 5 to 6  $^{\circ}\text{C}$ . After one hour of operation of the boilers, the temperature of the shower water was increased only by 1  $^{\circ}\text{C}$ . On the basis of these tests, it appears that the shower water can not be supplied from the electric boiler if a load control solution shall be established.

Before the project was started, the swimming pool already had made plans for establishing heating pumps to supply the showers with hot water. The project decided to wait with further evaluations of load control until these plans are fulfilled.

### **6.4.3 How to involve the customers**

In Figure 67 the characters of the different participants in the project are shown. In addition to E-CO Tech, electricians and performance contractors are involved in the implementation process dependent on the request from the customer. The performance contractor and the electrician company might also be the same company.

Today the electricity price in Norway consists of three parts: energy price, network tariff and taxes. Most customers in Norway have an energy price which follows the spot price in the competitive Nordic electricity market, Nordpool. This implies that most customers today have an energy price which makes about 40-60% of the total electricity price, while network tariff makes about 20-40% and the taxes make about 20%. The price signal from the network company affects the majority of the motivation key factors, mentioned in the following section about barriers experienced.

In the following figure the character of the different stakeholders in the project is shown.

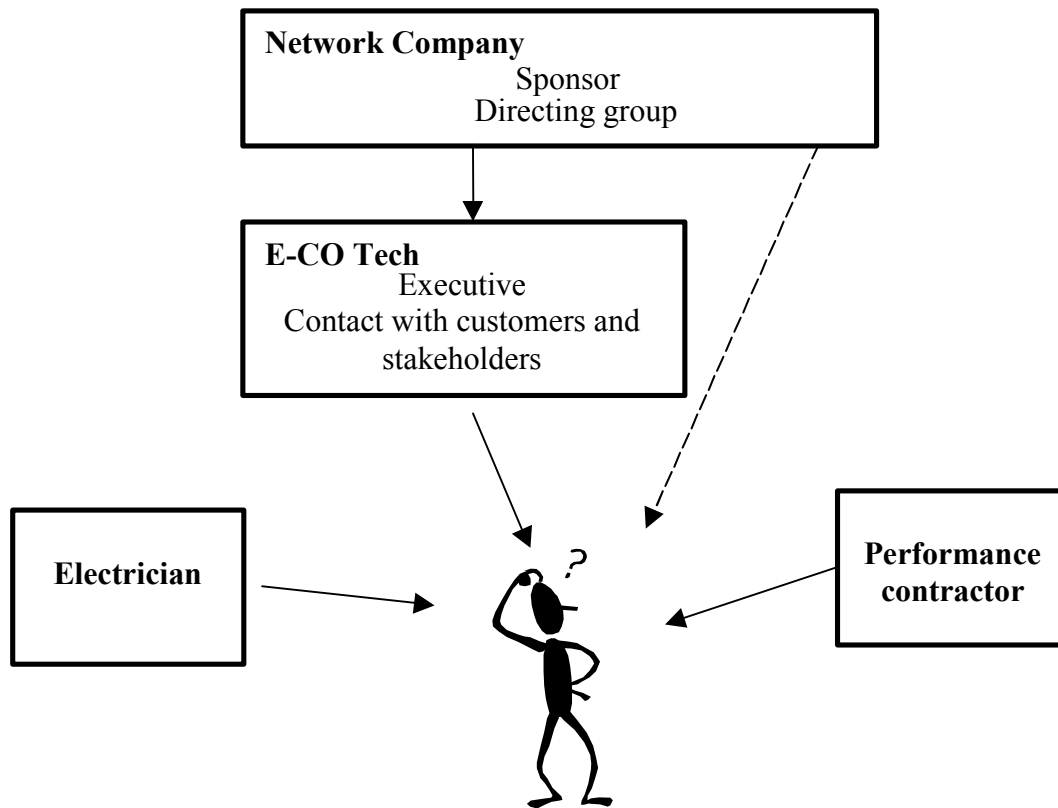

Figure 67. The character of the different stakeholders in the project

To promote remote load control actions the network company offered the 7 actual customers a new tariff related to the limited controllable or interruptible load. The network company require momentary load control or load control within 1 hour of alert. This is reflected in two pilot network tariffs that are offered in the project shown in Table 19. In the Table 19 below the existing tariffs for uninterruptible consumption and the two new offered tariffs for limited remote control of "uninterruptible" consumption is shown for customers connected to the lowest grid level.

Table 19. Network tariff agreement concluded with pilot customers

Type of network tariff	Grid level	Fixed price (Euro/year)	Power load interval (kW)	Power load price (Euro/kW)	Energy consumption price (Euro/kWh)			
					week no 2-14	week no 15-27	week no 28-40	week no 41-1
A Tariff for uninterruptible consumption, ordinary tariff for commercial customers in Oslo Pilot project [1];	230V or 400V	689	0-200	53	0,0127	0,0057	0,0034	0,0048
			200-1000	45				
			> 1000	37				
B New tariff offered for limited controllable or interruptible load "momentary remote control". Pilot project [2];	230V or 400V	689	-	17	0,0041	0,0028	0,0028	0,0041
C New tariff offered for limited controllable or interruptible load "remote control with 1 hour alert". Pilot project [2];	230V or 400V	689	-	28	0,0041	0,0028	0,0028	0,0041

The table above shows that the pilot customers were offered 40-60% reduction of the power load costs related to the load which is controllable or interruptible in limited periods. The network company require duration of at least 3 hour of each remote interruption or load control.

Looking at the first row (A) in the table, you can see the structure of the standard network tariff for commercial customers in the Oslo region. In addition to the power part and the energy part of the tariff, everyone pays a yearly fixed part at 689€. The powerpart has a stairway structure and is related to the particular hour of maximum peak load during the year, independent on when it occurs. The first 200kW of the peak cost 53€/kW, the next 800kW cost 45€/kW and the remaining kW cost 37€/kW. The customers that agreed on the two pilot tariffs (shown in row B and C), achieved a reduced and fixed €/kW-price of the power part as shown in the table (without stairway structure). The energy part and the fixed part in the pilot tariffs (B and C) were similar to the standard tariff (A).

## 6.5 Barriers experienced

Some of the main objectives in this pilot study have been to examine the barriers related to convince the customer to permit remote load control by the Network Company and the barriers related to make the customer himself invest in load control solutions (smart house solution). The loads that the project seeks to achieve controlled are vulnerable loads, mostly without any back-up system. These loads have hardly ever been remotely controlled before. To achieve this, the project has tried to give the customer the necessary incentive through a new pilot network tariff. The following main barriers have been discovered in this study of different customers (enterprises) with very different kinds of loads:

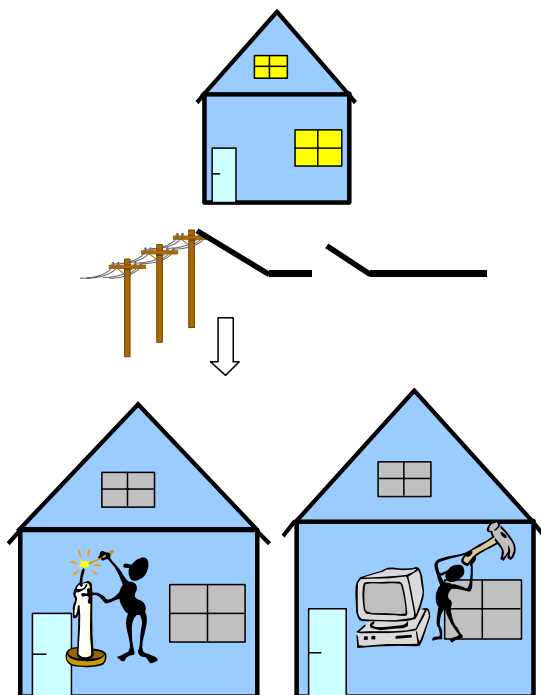

**Duration of load control**

One of the most important barriers is related to the duration of load control, which means interruption or downward adjustment of loads. Interruption tests of the high pressure pumps of the water pumping plant showed that two or three hours interruption was possible dependent on the time of rest between interruption and dependent on the number of interruption during the day. Interruption tests of the cooling compressors of the Skating Rink, showed that three hours interruption did not influence the ice-surface temperature considerably due to the air temperature 4-6 °C.

**Time of rest between each load control**

The time of rest between interruption is a critical barrier in all of the 7 cases of load control studied in this pilot. Test showed for instance that the water pumping plant needed at least 5 or 6 hours rest between each interruption to maintain sufficient water level in the magazines and the furniture dealer needed about 5 hours rest to maintain a minimum water temperature in the electric boilers.

**Number of load control**

The number of interruptions or downward adjustments of loads during each day, week, month or each year is critical for some of the customers. The computer central estimated that maximum 10-12 interruptions during the year was possible due to the cost per hour of running the back-up system (which are diesel generators) compared to the electricity cost per hour (referred to the pilot tariff offered). Both the water pumping plant and the furniture dealer could only agree on maximum two interruptions a day. The small industry plant could only agree on one interruption a day and a handful interruptions during the year. Due to the influence on the working staff and to the cost of stopping the copper melting furnaces, the small industry plant required complete stop of the plant during the whole day when a the Network Company effectuated the interruption.

**Alert before load control**

Through dialogue with the customers the project has experienced that for some customers it is difficult to decide whether an alert before load control is needed or not. It is often difficult to distinguish between a psychological barrier for cutting loose from the way of operation to day and the actual possibilities or limitations of the controllable load. In some cases, momentary interruption is possible exploiting new technological smart house solutions. Then, it appears as a question of cost-benefit of the technical solution of momentary load control. For instance, the water pumping plant required one hour of alert before interruption. Through a dialogue between the project group including the Network Company and the customer, the water pumping plant agreed on momentary automatic remote control on the postulation of a gradual downward adjustment of each of the high pressure pumps.

However, in some cases alert before load control is needed. For instance the computer central, needs one hour alert if the load interruption shall be combined with the monthly test running of the diesel generators. The small industry plant also need one hour of alert to empty the copper melting furnaces before shut down. The solution of alert is also critical for some customers. If any failure occurs to the alert signal (fax, email, sms, voice etc..), this could involve serious damage of the customers equipment, as well as irreparable damage on the activity, such as wrecked high pressure pumps, danger of explosion in the pressure system of the pumping plant, damaged copper melting delivery etc..

### **Technical solution for load control**

In some cases, finding the technical solution for load control can be the most difficult barrier of them all. This could be illustrated by looking at the engineering workshop. In this case both the complexity of the electrical distribution network within the buildings and the spreading of the loads, as well as, the small kW-size of the controllable loads, make a technical solution according to difficult and expensive. Due to this barrier the cost-benefit of the technical solution related to the Network tariff offered, will be cardinal to the customers decision. The decision of installing a building automation system for controlling all loads of the engineering workshop might be an alternative to reconstruction of the electrical distribution network inside the buildings.

### **Consequence of a possible failure of re-connection after load control**

Another important barrier to most of the customers are consequences from any signal failure that might occur when the particular loads are being connected after the interruption have taken place. For instance the consequence to the water pumping plant will be very critical if the water level of the magazines gets too low, and, especially, if the water pumping plant is not able to re-establish the needed water level. This might involve unsuspected consequences for the water supply system of the City of Oslo. However, if such a signal-failure from the Network Company occurs and the water pumping plant is able to re-establish the water level, it will lead to a very high resulting peak load due to operation of all high-pressure pumps including reserve pumps.

### **Extraordinary operational situations**

For some customers extraordinary operational situations might be a big barrier to realize any kind of remote load control, this, even if the probability for such a situation is very small. For instance, the water pumping plant is not able to accept a load control of any high-pressure pumps if a conflagration or inundation arise. Such a situation only occurs once every 10-20 years, and the likelihood that a load control will be activated simultaneously is extremely small. For other customers extraordinary operational situations happen more often. Then, this barrier might be more important.

### **Sufficient cost-benefit through the Network tariff**

Vital for all of the customers are the cost-benefit of the necessary investments for load control reflected from the network tariff. This barrier has been the main discussion subject during all meetings with the customers.

### **Organizational, ownership, business management og psychological barriers**

Barriers related to company organization, ownership, business management and psychology obviously have been cardinal for the customers decision. These issues have not been studied in this pilot, but are further analysed in the pilot project "Improving end-user knowledge for managing energy loads and consumptions".

## 6.6 Project results and key figures

In the following Table 20 the most important key figures of the implementation process for load control are summarized.

Table 20. Key figures of implementation of load control among 7 commercial customers

Customer	Controllable Power loads	MW controllable Power loads	Status of implementation process within the spring of 2004
No.1 Water pumping plant	8 high-pressure pumps	2,9 MW peak 1,5MW normal operation.	Offers from two electricians are received and the implementation will be completed within the spring of 2004.
No.2 Furniture dealer	2 electrical boilers, 6 air conditioning aggregates	1,3 MW peak 1 MW normal operation.	Offers from three electricians are received and the implementation will be completed within the spring of 2004
No.3 Computer Central	Interruption of computer-housing central, (diesel generators backup system)	3,2 MW peak 0,4 MW normal operation.	Because the pilot tariff only does reward interruption of load and does not reward supply of power load (from a diesel generator), The Computer Central can not find the "profit motivation" of implementation.
No.4 Sport centre	5 cooling compressors	1,7 MW peak 1,0 MW normal operation.	Due to high investment costs and present investment plans, implementation is not realised so far.
No.5 Small Industry plant	3 melting furnaces	1,7 MW peak 1,5 MW normal operation.	Due to customer discontent of the pilot tariff offer, the implementation process has been temporary stopped.
No.6 Engineering workshop	Many small loads; motors, heater batteries, fans, water heaters etc.	1,8 MW peak 0,8 MW normal operation.	Due to the plans of installing a building automation system, the implementation process has been postponed
No.7 Public Swimming Pool	Two electric boilers	1,8 MW peak 1,0 MW normal operation.	Due to the plans of installing heating pumps, the implementation process has been postponed.

## 6.7 Conclusions

A considerable potential for controllable power load is documented among 7 out of 14 customers. These 7 customers have a total maximum peak load of 18.1MW and have been offered a new pilot tariff from the Network Company, Viken Nett. The potential for controllable load among the 7 customers is estimated to 8.8 MW or 49% referred to maximum peak load. The new pilot tariff shall give the customers cost-benefit incentives for investing in load control solutions, as well as giving incentives for letting the Network Company remote control the particular loads in limited time periods.

Through the study of the 7 commercial customers with potential for controlling "vulnerable" loads in limited time periods, one has learned that several barriers besides cost-benefit from load control investment are cardinal to the customers' decision. In all of the seven pilot cases, (water pumping plant, furniture dealer, computer central, outdoor skating rink, small industry plant, engineering workshop and a public swimming pool) the cost-benefit of the necessary investment by the customer has been reflected by one or several of the following barriers:

- Duration of load control
- Time of rest between each load control
- Number of load control during the day, week, month or year
- Alert before load control
- Technical solution for load control
- Consequence of a possible failure of re-connection after load control
- Extraordinary operational situations
- Organizational, ownership, business management and psychological barriers

The seven commercial customers have been offered a new network tariff which involves a price reduction due to an agreement of automatic remote load control performed by the Network Company. Two of the seven customers have agreed to use the pilot tariff and to make the necessary investments themselves for load control solutions (smart house solutions) specified by the project. The other five customers are not willing to invest in load control solutions due to the cost-benefit and due to the other mentioned barriers.

The Network Company has decided to continue in 2004 following-up the five customers that have rejected the offered pilot network tariff. The purpose of this further study is to look into if any other adjustments or revision of the pilot tariff and the introductory sale process might cause increased interest of making an agreement of automatic remote load control.

## **7 Norwegian Pilot 3: End-user flexibility by efficient use of ICT**

### **7.1 Introduction**

The Norwegian project “End-user flexibility by efficient use of ICT” is by the Norwegian sponsors of the EFFLOCOM project defined as an EFFLOCOM pilot project. This means that the main results and general conclusions from this project are available for the EFFLOCOM project group.

### **7.2 Project overview**

#### **7.2.1 Objective of the pilot**

Due to very tight peak power balance in the Nordic power system, and with hardly any investments in new production, focus has turned towards manual or automatic demand response, which implies need for hourly metering for documentation, and controllability in order to meet the response requirements. The Norwegian pilot 3 involves establishment of Direct Communication (two-way communication), including hourly metering and separate channel for remote control, to altogether 10 895 customers in two different network areas.

The objective is to increase the end-user flexibility in periods with scarcity of electrical energy and power by:

- Establishing a decision basis and suggest external conditions for a prioritised building of an infrastructure based on ICT-solutions for direct communication and load control.
- Develop, test and evaluate different incentives, which stimulates to flexibility in consumption, with basis in network tariff, power products and other market solutions.

#### **7.2.2 Technology requirements and implementation**

Technology for direct communication is installed at customers located in the concession areas of the network operators Buskerud Kraftnett and Skagerak Nett. The selection of these network operators were based on a tender invitation sent to all Norwegian network operators, autumn 2001.

A requirement specification focusing on functionality concerning metering of electricity consumption and load control was included in the tender invitation. The network operators were free to choose the technology as long as the functionality requirements were fulfilled. The technology for two-way communication should be installed at both household customers (8-40 MWh/year) and industrial customers (40-100 MWh/year).

The requirements for hourly metering was set due to the possibility to offer time-of-use (ToU) tariffs and power contracts with time variable prices to the customers. Additionally load control was required to utilise the customers' flexibility in electricity consumption.

### 7.2.3 Description of the customers

The technology for direct communication is installed at both household and industrial customers. This implies that all the customers have an Automated Meter Reading System (AMR) and a relay for remote load control (RLC). ~50 % of the customers accepted RLC and were paid ~100 € for this.

It is assumed that all the end users can divide their load into a **low prioritised** and a prioritised part. In this pilot the low prioritised appliances are the objects included in the agreement of load reduction between the network operator and the end user. Different kinds of low prioritised loads are defined, but only boilers for water heating are used.

The household customers are a uniform group of customers where the boiler for water heating, and some floor heating are the appliances that are most relevant for load control. The commercial customers' appliances turned out to be less reducible than expected. Only smaller water heaters are used in the tests.

The allocation of the customers in different groups is presented in Table 21.

Table 21. Customer groups

	Metering of electricity consumption		Load control
	Hourly metering	Daily metering	
<b>Buskerud Kraftnett</b>			
Household	3237	1440	2622
Commercial	342	3	44
<b>Skagerak Nett</b>			
Household	5808	0	2480
Commercial	65	0	49

### 7.2.4 Power Shortage characteristics

An important initiating part of the project was to define the characteristics of a power shortage situation as an indication to the end-user of capacity problems in the power system. The following was chosen:

- Define periods with shortage from high spot prices

- Define peak load hours for the design of network tariffs
- Special warning from System Operator and/or Network Operator when critical shortage occurs.

### **7.2.5 Criteria of automatic load reduction**

Three criteria of automatic disconnection of low prioritised loads were defined:

- *Spot price criterion* – Low prioritised loads are disconnected when the spot price exceeds a predefined limit.
- *Reserves criterion* – Low prioritised loads are disconnected when capacity shortage in the grid or the power system occurs.
- *Max power criterion* – Low prioritised loads are disconnected when the end user load exceeds a predefined limit.

Due to technical limitations only the spot price and the reserves criteria were tested.

Skagerak Nett is using the spot price criterion for load control. This implies that loads are disconnected in two hours morning and evening during peak load periods, when the spot price exceeds a predefined limit. This limit was initially set to 0,0625 €/kWh, but due to low spot prices in the test period, the limit was removed. In the last months of the pilot the loads are disconnected two hours every morning and evening, when the spot prices are highest.

The customers connected to Buskerud Nett have been offered two criteria for load reduction. When the technology for load control was installed, the customer got into an agreement with the network operator for disconnection of load when power reserves are needed, or if the situation in the network required disconnection. Additionally the customers got an offer from the power supplier, for load reduction in two hours during both the morning and the evening, in peak load periods.

### **7.2.6 Network tariffs**

Five different network tariffs were developed in the project:

- Time of Use (ToU) energy tariff for household customers
- ToU power tariff for commercial customers
- Dynamic tariff with multiplied spot price part for household customers
- Dynamic tariff with temperature dependent part for household customers
- Disconnectable tariff for commercial customers

The following ToU tariffs for households and commercials were used in the main test period:

$$\text{ToU Energy tariff}_{\text{households}} = \text{Fixed part} + \text{Network losses part} + \text{Variable energy part}$$

$$\text{ToU Power tariff}_{\text{commercial}} = \text{Fixed part} + \text{Network losses part} + \text{Variable Power part}$$

The variable parts of the tariffs are only activated in periods defined as peak load (See Figure 68).

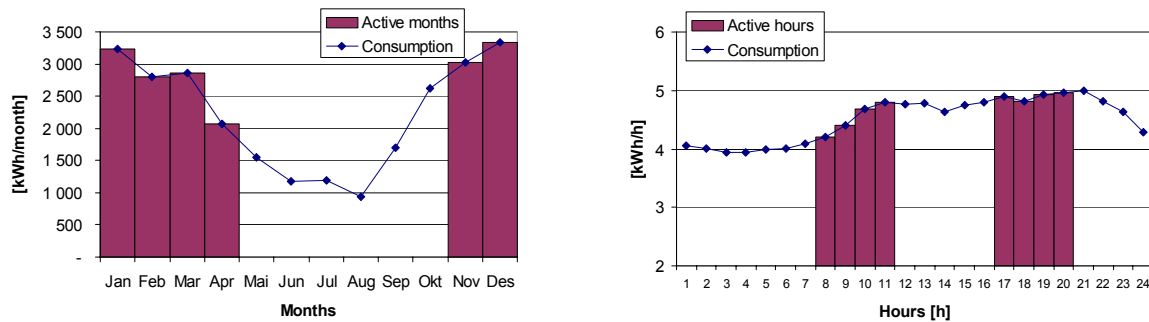

Figure 68. Months and hours defined as peak load

The price levels of the variable parts were:

- Household customers get extra cost per kWh consumed electricity in peak load periods. The extra cost is 0,15 €/kWh.
- For industrial customers the consumption in peak load periods is the basis for the power costs. A price per kW is set on the average of the three hours with highest consumption per month. The extra cost is 10 €/kW.

### 7.2.7 Power contract offered

New product designed for customers with hourly metering and load control option were developed in cooperation with the main power suppliers in the concession areas of the two network operators:

- *Hourly Spot price* with predefined load reduction (spot price criterion)
- *Fixed price* combined with predefined load reduction (spot price criterion)
- *Combination* of fixed price and hourly spot price

In the pilot power suppliers have offered a power contract with spot price on an hourly basis. The idea behind the hourly power contract is that the customers should be able to reduce their costs by load reduction in peak hours.

The power supplier that operates in the area for Buskerud Kraftnett has included a service for load control in the power contract. The service implies that the water heater will be disconnected for two hours during both the morning and the evening, when the spot price is high.

### 7.2.8 Project activities and time schedule for accomplishment

The project started in 2001 and will be terminated in the summer of 2004. The focus in the project is the pilot test. In the winter 02/03 a small test for load reduction was performed. The main test is accomplished in the winter 03/04, from 1 November to 30 April. The time schedule for the pilot test is presented below.

ID	Task Name	Start	Finish	2001		2002				2003				2004			
				Q3	Q4	Q1	Q2	Q3	Q4	Q1	Q2	Q3	Q4	Q1	Q2		
1	Tender invitation	2001-08-01	2002-01-18	■													
2	Installation of Direct Comm.	2002-01-18	2003-10-01	■													
3	Main pilot test	2003-11-03	2004-04-30	■													
4	Analysis	2004-01-01	2004-07-01	■													

During the main pilot test the customer will react on the new time-of-use tariffs and power contracts. Additionally special tests for load control are carried out. The periods for these tests are presented in Figure 69.

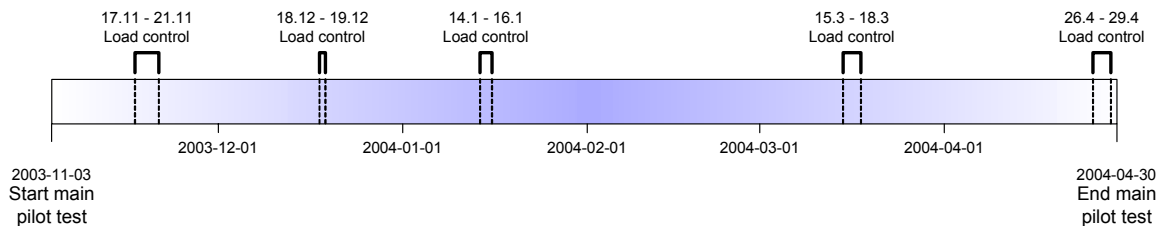

Figure 69. Time schedule for special tests for load control

## 7.3 Achieved results and key figures

### 7.3.1 Customer agreements

In this chapter the different agreements and the actors involved are presented for both the network operators. The arrangements in the two different parts of the pilot differ, and it is therefore presented two different figures.

A water heater is the appliance that is mainly defined as low prioritised load and used for load control. This is denoted as "HW" in the next two figures.

Figure 70 presents the agreements in the pilot test at Buskerud Kraftnett. A terminal for hourly or daily metering of the electricity consumption is connected to the meter installed at all customers. Additionally a relay for load control is connected to the terminal at the customers with the possibility for load control (based on the reserve criterion).

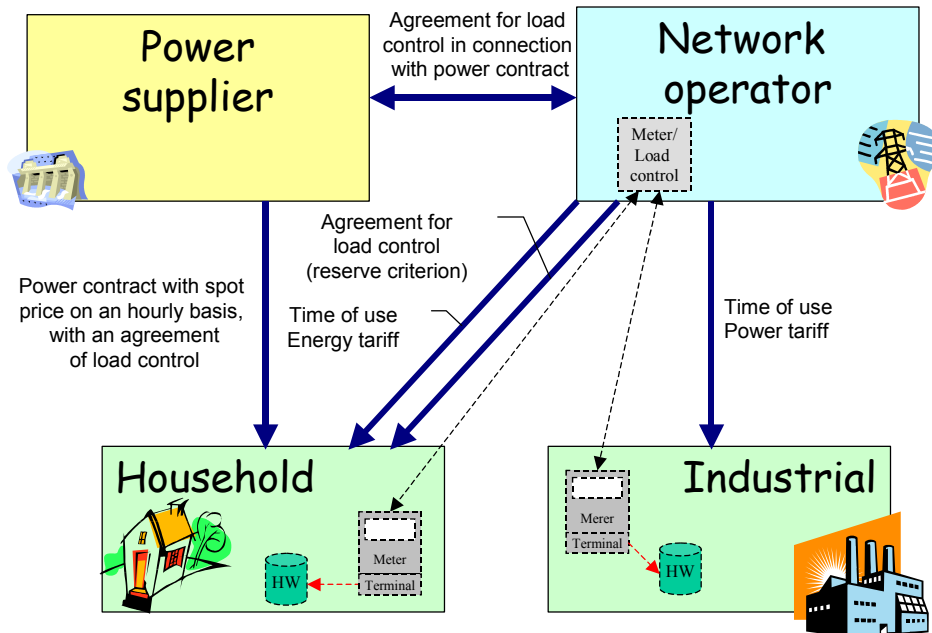

Figure 70. Actors and agreements Buskerud Kraftnett (Network Operator)

At Buskerud Kraftnett both the time-of-use energy and power tariff were tested. Additionally some household customers have a power contract with spot price on an hourly basis. An agreement for load control in predefined hours (based on the spot price criterion) can be included in the contract with power supplier. Nearly 80% of the customers with a power contract on an hourly basis and the possibility for load control have accepted this agreement. For these customers it is the network operator that performs the load control on behalf of the power supplier.

The agreements concerning Skagerak Nett and the technology installed are presented in Figure 71. A terminal for hourly metering of the electricity consumption is connected to the meter installed at all customers. For some of the customers with the possibility for load control, a relay is installed in the terminal. For other customers a separate system for load control is used, where the relay is placed between the wall outlet and the appliance.

At Skagerak Nett both the time-of-use energy and power tariff are tested. Additionally some household customers have a power contract with spot price on an hourly basis. The customers do only have an agreement for load control with the network operator, based on the spot price criterion.

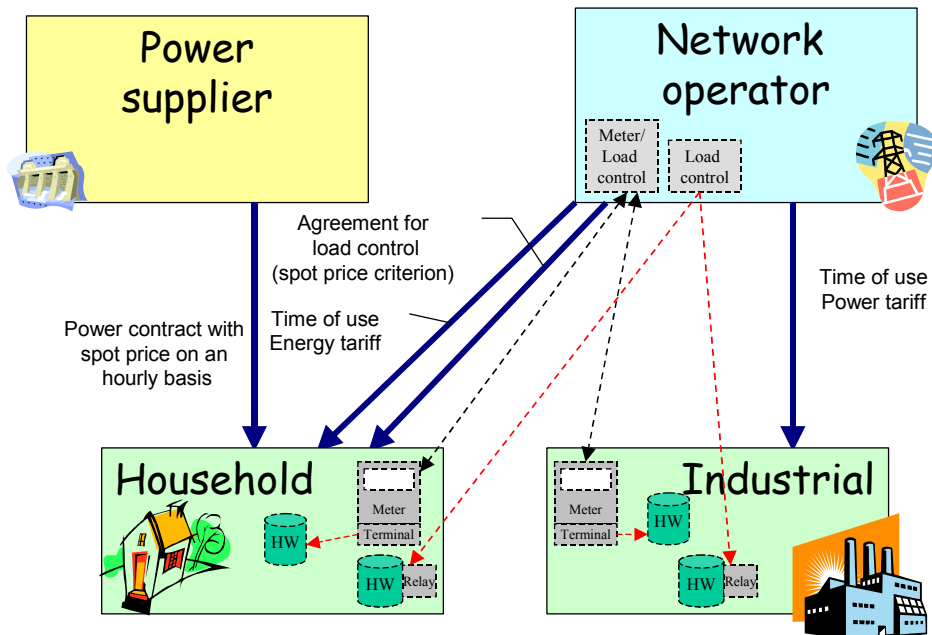

Figure 71. Actors and agreements Skagerak Nett (Network Operator)

A summary of the different agreements is presented in Table 22.

Table 22. Criteria and price signals included in the pilot

Network operator \ Pilot		Buskerud Kraftnett		Skagerak Nett	
		Household	Industrial	Household	Industrial
Network tariff		Time-of-use Energy tariff	Time-of-use Power tariff	Time-of-use Energy tariff	Time-of-use Power tariff
Power contract		Spot price on an hourly basis	-	Spot price on an hourly basis	-
Load control	General	Reserve criterion	Reserve criterion	Spot price criterion	Spot price criterion
	Related to power contract	Spot price criterion	-	-	-

### 7.3.2 Technology

Technology and communication from six different vendors are used in the pilot. In Figure 72 a general illustration of the technology is presented. The description is separated in three different levels: central level, communication level and the customer level. The *central level* will in most cases be at the network operator and includes different type of so-called front

end systems, one for each type of system. The *communication level* shows different types of communication. The *customer level* illustrates the technology at the end user. The terminal received data from the meter. It may also perform load connection/disconnection (WH –water heater) based on signals from the front-end system.

Buskerud Nett used technology that communicated on the medium voltage lines, on low voltage lines/GSM, radio communication and a few on GSM directly.

At Skagerak Nett the collection of meter values was performed by communication on low voltages lines in combination with GSM. The control of loads was performed by a separate radio based system (Ebox).

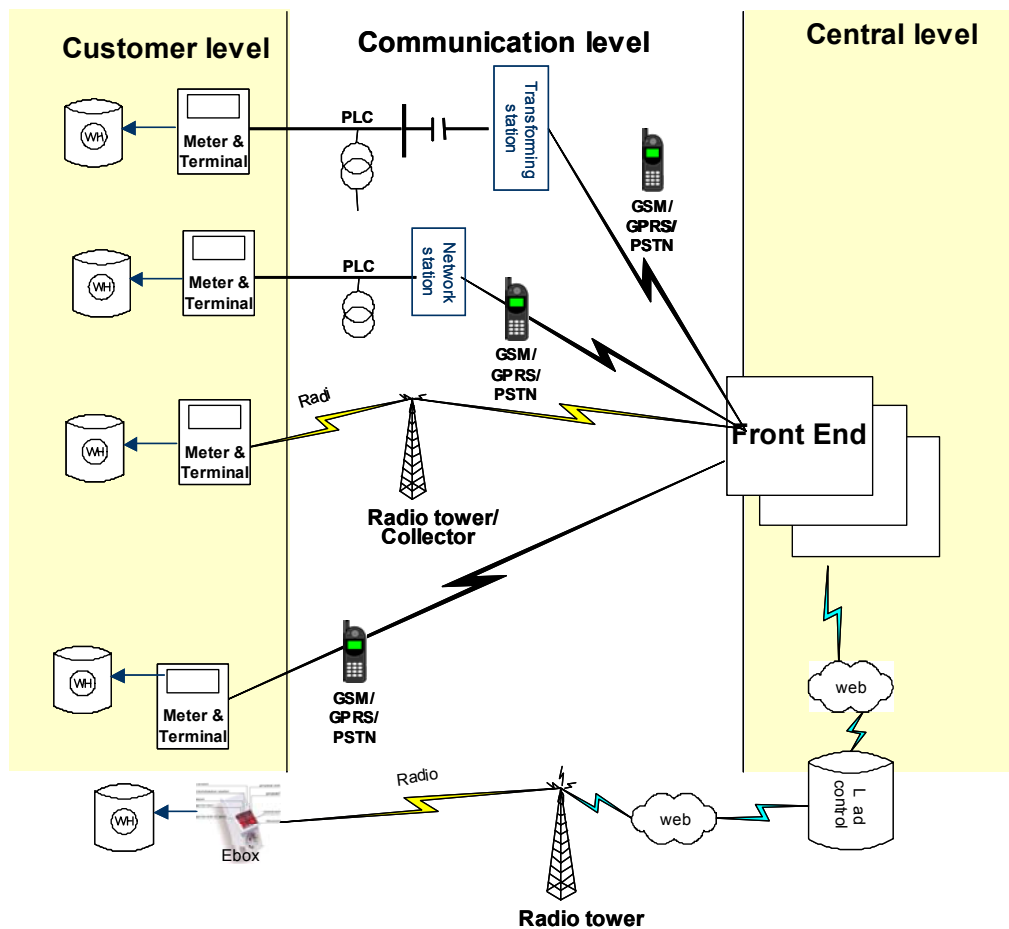

Figure 72. General technology description for the pilot

### 7.3.3 Experiences with the technology

More problems than expected were experienced from all the vendors, both the large international concerns as well as the smaller Norwegian companies. Previously, Direct Communication had been established to large customers, but the number of customers was in most cases maximum a few hundred. An important experience was that it is different to establish technology to several thousand customers than to a few hundred. With establishment to several thousand there will be a lot more data to handle and the technology

will be more loaded down.

In general, errors occurred in all the systems and in all parts of the systems. Examples of problems or deficiency with the technology were:

- GSM modems that frequently went into a blocked mode.
- Different versions of a system that did not work together.
- Radio antennas mounted inside the fuse box turned out to give too bad communication results, and the antennas had to be moved outside the fuse box. 1000 customers had to be visited a second time to move the antennas.
- Systems that were programmed from factory with wrong parameters
- Too long response time for remote load control. Performance of remote load control of 200 customers took 2 hours while the requirements said 15 minutes.

However, the lessons learned in the project indicate that there is a potential of improvements. The technology will probably be improved as a consequence of the project.

The figures below show the development of quality of metered data at Buskerud Kraftnett and Skagerak Nett from August 2003 to May 2004. 100% data quality in one week means that all hourly values from all customers is received.

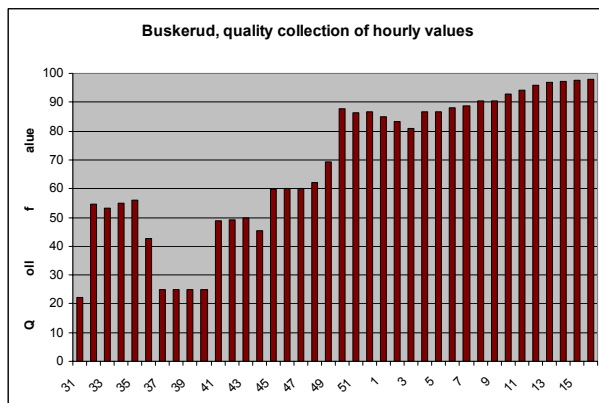

Figure 73. Buskerud Kraftnett, Quality of collection of metered data Aug 2003 – May 2004.

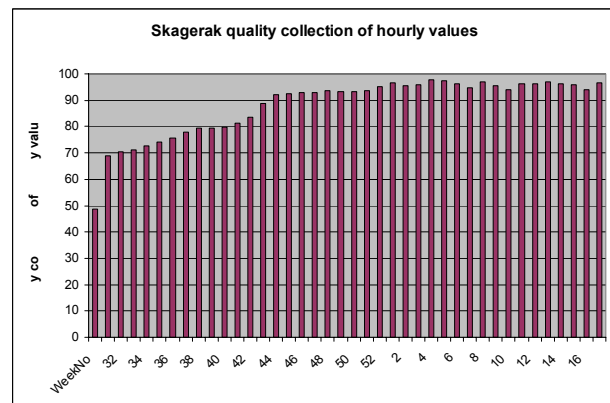

Figure 74. Skagerak Nett, Quality of collection of metered data Aug 2003 – May 2004.

### 7.3.4 Large scale pilot tests – Achieved results

Analyses have been performed based on the meter data from the customers participating in the project. The main results are presented below.

The different elements in the pilot test: Special test weeks with load control in specific hours, the time-of-use (ToU) tariff and spot price on an hourly basis with/without load control. Customers that do not have load control, have to react on the tariff or spot price by investing in control system at home or changing the consumption pattern by changing habits.

In the next figures the defined peak load periods are marked with light green sections.

In most cases consumption data for the same customers are used both for active curves as well as for reference curves. The reference data are from week 42 in 2003, just before the

new tariffs became active. The curves are corrected for changes in the temperature. All the curves are also normalized. In the case of remote load control, consumption data from similar customers in the same consumption area is used as reference.

### Buskerud Kraftnett

Figure 75 shows the results from remote control of loads at household customers. The reference curve is based on consumption at similar customers in the same period and the same geographical area.

The consumption is reduced as a result of the remote load control compared to the reference. The reduction is 12 % in the morning and 14 % in the afternoon.

Number of customers: 1230.

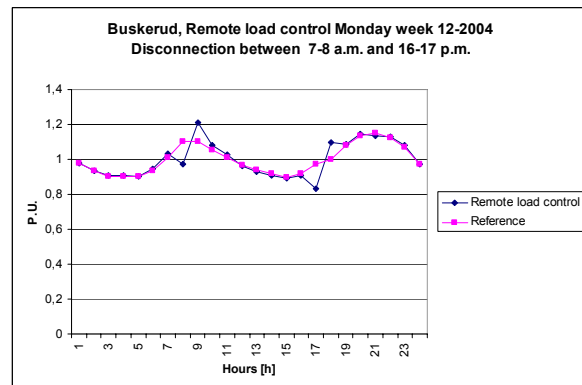

Figure 75. Remote load control

Figure 76 shows the results from the use of the time-of-use energy tariff for household customers. These customers do not have technology for load control.

The electricity consumption is reduced in peak load periods, compared to the reference. The maximum change is 10% during the morning and 7% during the afternoon.

Number of customers: 39.

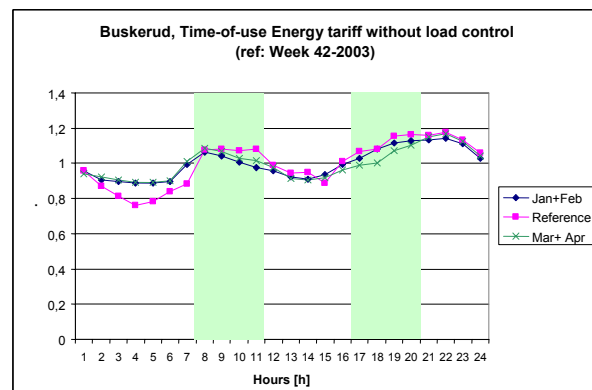

Figure 76. ToU Energy tariff without load control

Figure 77 shows the results from the use of power contract with spot price on an hourly basis. The figure presents the consumption for household customers without technology for load control.

The figure shows a reduction in the electricity consumption in both peak load periods, compared to the reference curve.

The maximum change is 15% during the morning and 22% during the afternoon.

Number of customers: 17.

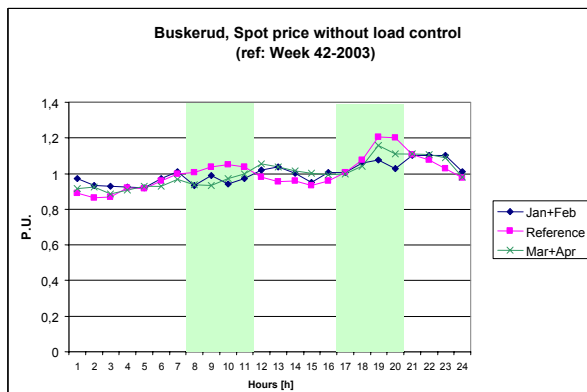

Figure 77. Spot price without load control

Figure 78 shows the results for household customers with both time-of-use energy tariff and spot price on an hourly basis.

The figure shows considerable reduction in the consumption during the two peak load periods. The maximum reduction is 35% during the morning and 31% during the afternoon.

Number of customers: 6.

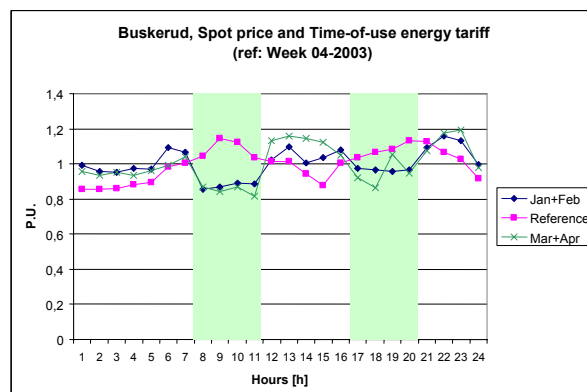

Figure 78. Spot price and ToU Energy tariff

### Skagerak Nett

Due to problems with the technology at Skagerak Nett, there are no results from remote load control at Skagerak.

Figure 79 shows the results from the use of the time-of-use energy tariff for household customers. These customers do not have installed technology for load control.

The electricity consumption is reduced in peak load periods, compared to the reference. The maximum change is 8% during the morning and 9% during the afternoon.

Number of customers: 198.

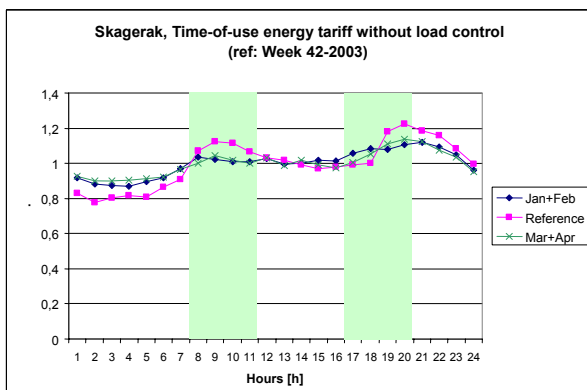

Figure 79. ToU Energy tariff without load control

Figure 80 shows the results from the use of power contract with spot price on an hourly basis. The figure presents the consumption for household customers without installed technology for load control.

The electricity consumption is reduced in both peak load periods, compared to the reference. The maximum change is 16% during the morning and 24% during the afternoon.

Number of customers: 34.

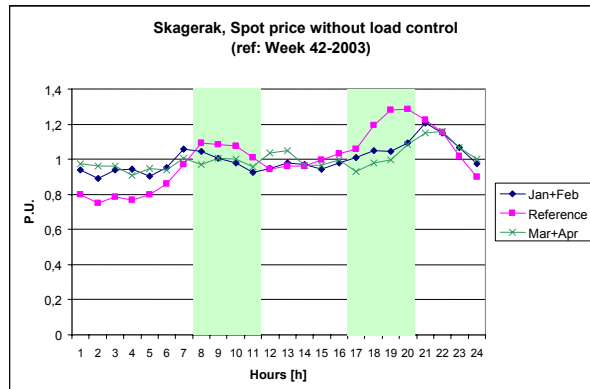

Figure 80. Spot price without load control

Figure 81 shows the results for household customers with both time-of-use energy tariff and spot price on an hourly basis.

The figure shows considerable reduction in the consumption during the two peak load periods. The maximum reduction is 14% during the morning and 28% during the afternoon.

Number of customers: 24.

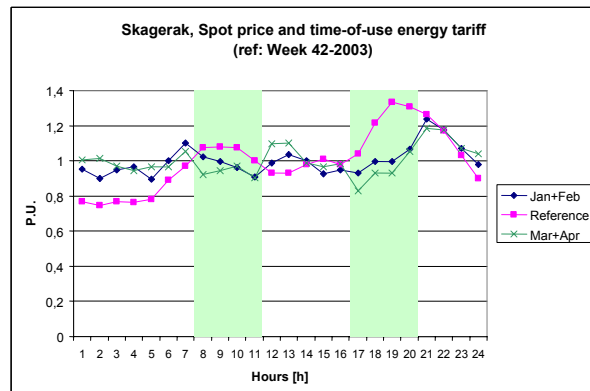

Figure 81. Spot price and ToU Energy tariff

Table 23 shows the registered peak load response of the involved customers in the two network areas.

Table 23. Average load reduction in the peak hour

Test description	Network Operator I	Network Operator II
Remote control (Disconnection of water heaters)	~0,5 kWh/h	~0,57 kWh/h
Tou energy tariff (price difference high/low load: ~0,125 €/kWh )	~0,18 kWh/h	~0,18 kWh/h
Hourly spot price	~0,6 kWh/h	~0,4 kWh/h
ToU + Hourly spot price	~1 kWh/h	~0,3 kWh/h

### 7.3.5 Cost/benefit analysis

The following table summarizes the economical figures of establishment of direct communication to 10 894 customers. The costs and benefits are related to the network operators solely.

Table 24. Cost /benefit analysis

	Skagerak		Buskerud	
	[Euro] per year		[Euro] per year	
	Total	Per point	Total	Per point
Investment costs *)	- 343 000	- 57	- 234 000	- 57
Operational costs	- 190 000	- 32	- 127 000	- 25
Total costs	- 533 000	- 89	- 361 000	- 82
Cost reductions / benefits	84 000	14	64 000	13
Net Cost/benefit	- 449 000	- 75	- 297 000	- 69

\*) 8,5 %, 10 years

It is important to note that these figures are from a test project *with many technological and organisational challenges*. As indicated in chapter 7.3.3, there are reasons to believe that lessons learned from this test project will make it possible to improve this figure considerably in future projects.

Nevertheless, the figures from this project as in many other projects involving this kind of infrastructure are negative. This means that the projects should not be carried out unless additional benefits to the society and/or other actors could be provided.

The following additional benefits are identified in this project:

- Society: Environmental benefit due to reduced need for new production and power lines
- Supplier: Reduced risk in the power market and improved customer relations
- Customer: Potential of electricity cost reduction

This implies that the society via regulations should promote establishment of the investments in Direct Communication that are proven socio economic beneficial. Additionally arrangements for payment from other actors to the network operator should be developed.

## 7.4 Conclusion and recommendations

The establishment of Direct Communication and the tests of demand response in this pilot lead to the following conclusions:

- Technology: Many problems occurred in the implementation phase. The quality of the meter readings was below expectations. Potential of improvements is identified.
- Registered demand response: ~ 0,3 kW/point (when 50 % participation is taken into consideration and 20 % reduction in network losses is included). The experiences from the ToU tariffs and hourly spot price products were good.

Recommendations for further development of Direct Communication to smaller customers (<100.000 kWh/year), based on experiences from the pilot test:

- The technology should be prepared for hourly metering and remote load control.
- The quality requirement of automatic metered data should be defined.
- Market based solutions for load control should be further developed.
- ToU tariffs and hourly spot price products should be offered to all hourly-metered customers.
- Implementation of technology for remote load control should be implemented stepwise, based on target figures from the authorities (for example referred to the yearly increase in peak load).
- Subsidies from the authorities should be considered. The subsidies should be limited to the cost of alternative investments in power (in Norway equivalent to the cost of an extra kW in an existing hydro power station  $\approx 25 \text{ €/kW/Year}$ ).
- Tender procedure is recommended to promote cost effective solutions.
- Further development of technology for Direct Communication should focus on:
  - Standardisation of interfaces
  - Quality assurance of meter values in customer information systems and meter value databases.
- A Nordic coordination of authority regulations is necessary since all the Nordic countries benefit from flexibility in electricity consumption.

## **8 Conclusions and recommendations from the pilots**

The following general conclusions and remarks can be drawn on the basis of pilot studies:

- Dynamic pricing like Tempo at EdF has high effect on consumption patterns of customers, if the price differences between cheap and expensive times are high enough: on the other hand, in competitive market new thinking on pricing have to be applied.
- In competitive market the pricing of electricity is a key factor. Network pricing should give TOU-type pricing as an attractive alternative to customers with higher consumption. Network pricing should stay stable so that customers can also make investments on the basis of that. With these kinds of pricing large effects on the consumption profile can be achieved as the Finnish situation shows.
- Energy pricing should be transparent showing market prices to customers. Different types of risk sharing products can be applied including TOU-type pricing.
- In several cases, DSM actions can be proved to be profitable compared to conventional grid reinforcements. To achieve this, the means which are used have to comply with the incentives and goals among both the Network Company and the customer. All experience shows that customers have to be strongly motivated to implement energy efficient actions, in spite of the fact that the customers can save money for themselves.
- Customers have ability to react on changing prices if it is easy for them as the pilots showed. They can also tolerate some minor discomfort if they understand the reason and/or are paid for that. Especially the households with electric heating have shown to be flexible for demand response.
- There are potential at commercial/small industrial customers for load control to respond to special tariffs with automatic remote control performed by the outsider like Network Company, but there are also several barriers at customers to accept control and to make required investments: further work has to be done to overcome these barriers.
- Automatic ways to react on prices have still to be further developed to all kind of customers: customers are not willing to follow their own consumption continuously although web-based feedback is useful. Interconnections to building/process/home automation are needed. Next generation of technology can enable a much more flexible system having access to individual management of the single appliances and end-uses
- The rules/methods to get controllable loads into market need still to be developed especially in case of small and medium size customers (< 10 MW)

- Technology for automatic meter reading and control of loads is still quite expensive and partly unreliable. Further development of technology for direct communication is needed especially in standardisation of interfaces and quality assurance of meter values in customer information systems and meter value databases.
- The cost of the remote meter reading at small customers is still too high. The sharing of costs with several service providers could reduce the costs and give possibilities to develop new products and services
- On the other hand, unbundling of businesses and competition increase the barriers for utilising new technologies due to difficulties to share the costs between different actors.
- The feedback to customers on electricity consumption should be simple and understandable: for ex. hourly consumption data itself is too complicated to analyse by ordinary customers.