

SINTEF A26762 - Unrestricted

Report

Wireless Instrumentation for Safety Critical Systems

Technology, Standards, Solutions and Future Trends

Author(s)

Stig Petersen
Niels Aakvaag





SINTEF IKT
SINTEF ICT
Address:
Postboks 4760 Sluppen
NO-7465 Trondheim
NORWAY
Telephone:+47 73593000
Telefax:+47 73594302
postmottak.ikt@sintef.no
www.sintef.no
Enterprise /VAT No:
NO 948 007 029 MVA

KEYWORDS:
Wireless Sensor
Networks, Wireless
Instrumentation,
Functional Safety,
Safety Critical Systems

Report

Wireless Instrumentation for Safety Critical Systems

Technology, Standards, Solutions and Future Trends

VERSION
2.0

DATE
2015-03-10

AUTHOR(S)
Stig Petersen
Niels Aakvaag

CLIENT(S)
PDS Forum

CLIENT'S REF.
Håkon S. Mathisen

PROJECT NO.
102001186

NUMBER OF PAGES/APPENDICES:
50 + Appendices

ABSTRACT

Wireless communication is an important part of everyday life, but has until recently been considered too unreliable for use in industrial processes. In particular, there has been reluctance to accept wireless systems as part of safety critical operations. This report considers the pros and cons of wireless communication in Safety Instrumented Systems. The report provides an introduction to wireless sensor networks (WSNs), the underlying technology for wireless instrumentation, presenting the history and basic technology enabling the recent development of low-power sensors and actuators. An overview of the different international standards for WSNs is provided, with special focus on the two specifications specifically targeting the process industries; namely WirelessHART and ISA100.11a. Furthermore, current status of wireless instrumentation within the oil and gas industry is summarized, including the financial and operational drivers for going wireless, along with the technical requirements which must be fulfilled for a successful adoption of this new technology. Example reliability calculation of wireless detector system is presented, and the wireless gas detector GasSecure is presented as a case. Finally, future trends and the consequences of using wireless instrumentation in safety critical systems are presented discussed.

PREPARED BY
Stig Petersen

SIGNATURE

CHECKED BY
Lars Bodsberg

SIGNATURE

APPROVED BY
Stein Hauge

SIGNATURE

REPORT NO.
SINTEF A26762

ISBN
978-82-14-05938-0

CLASSIFICATION
Unrestricted

CLASSIFICATION THIS PAGE
Unrestricted

Document history

VERSION	DATE	VERSION DESCRIPTION
1.0	2014-10-15	Draft for comments from PDS members
2.0	2015-03-10	Final version

Preface

This report is a deliverable from the research project: "Tools and guidelines for integrated barrier management and reduction of major accident risk in the petroleum industry" (2012-15). The project has been funded by the PETROMAKS2 programme for petroleum research at the Research Council of Norway and industry participants of PDS forum.

PDS forum is a co-operation between oil companies, engineering companies, drilling contractors, consultants, vendors and researchers, with a special interest in safety instrumented systems in the petroleum industry. The main objective is to maintain a professional meeting place for:

- Exchange of experience and ideas related to design and operation of Safety Instrumented Systems (SIS)
- Exchange of information on new field developments and SIS application areas
- Developing guidelines for the use of new standards on safety and control systems
- Developing methods and tools for calculating the reliability of SIS
- Exchange and use of reliability field data

Participants PDS forum

Oil companies / Operators:

A/S Norske Shell
BP Norge AS
ConocoPhillips Norge
Eni Norge AS
GDF SUEZ E&P
Odfjell Drilling & Technology
Marathon Petroleum Company (Norway) LLC
Talisman Energy Norge
Teekay Petrojarl ASA
Statoil ASA
Total E&P Norge AS

Governmental bodies (observers):

The Norwegian Maritime Directorate
The Petroleum Safety Authority Norway

Control and Safety System Vendors:

ABB AS
FMC Kongsberg Subsea AS
Honeywell AS
Kongsberg Maritime AS
Origo Solutions AS
Siemens AS
Simtronics ASA

Consultants / Engineering companies:

Aker Engineering & Technology AS
Aker Subsea AS
DNV GL Norge AS
Fabricom AS
Lilleaker Consulting AS
Safetec Nordic AS
Lloyd's Register Consulting



<http://www.sintef.no/PDS>

Table of contents

1	Introduction	8
1.1	Background	8
1.2	Content of report	8
2	Wireless sensor networks	9
2.1	History	9
2.2	Technology	10
2.2.1	Wireless sensor node	10
2.2.2	Network topologies	11
2.2.3	Routing	12
2.2.4	Time-division multiple access and frequency-division multiple access	13
2.2.5	Security	14
3	International standards	15
3.1	IEEE 802.15.4	15
3.2	ZigBee / ZigBee PRO / ZigBee IP	15
3.3	6LoWPAN	16
3.4	WirelessHART	16
3.5	ISA100.11a	16
3.6	WIA-PA	17
3.7	WirelessHART vs ISA100.11a	17
3.7.1	Flexibility	17
3.7.2	Protocol support	18
3.7.3	Coexistence	18
3.7.4	Quality of Service	19
3.7.5	Security	20
3.7.6	Suitability for safety applications	20
4	Wireless instrumentation in the oil and gas industry	22
4.1	Financial and operational drivers	24
4.1.1	Greenfield	24
4.1.2	Brownfield	25
4.1.3	General	25
4.2	Requirements	26
4.2.1	Technical requirements	26
4.2.2	Application specific requirements	27
4.2.3	Operational considerations	28
4.3	Current status	30

5	Wireless instrumentation in safety critical systems.....	31
5.1	Standards	31
5.1.1	General safety standards.....	31
5.1.2	Fieldbus communication	31
5.1.3	PROFIsafe.....	33
5.2	Important definitions.....	33
5.2.1	Process Safety Time (PST).....	34
5.2.2	Safety function response time (SFRT).....	34
5.2.3	Availability and probability of failure on demand	34
5.3	Availability calculation	35
6	Comparison wired and wireless detector systems.....	37
6.1	Difference between wired and wireless detector systems	37
6.2	Reliability Assessment.....	38
6.2.1	Example case	38
6.2.2	Example Reliability Block Diagrams	39
6.2.3	Safety Unavailability Calculation	41
7	Case Study: GasSecure	44
7.1	Timing issues	44
7.2	Communication considerations	44
8	Future trends	46
8.1	Safety topology	46
8.2	Short cycle time	47
9	Summary and conclusions.....	48
	References.....	49

Table of figures

Figure 1: Wireless sensor node.....	11
Figure 2: Examples of network topologies: a) star, b) mesh, c) hybrid star-mesh	12
Figure 3: Examples of graph routing.....	12
Figure 4: TDMA timeslots, frames and superframes	13
Figure 5: Data transmission and acknowledgment within a timeslot	13
Figure 6: Communication Protocol Stacks	15
Figure 7: Evolution of field device communication technologies – simplified architecture.....	22
Figure 8: Field instrumentation application areas and usage classes.....	23
Figure 9: Commuication contribution to PFD.....	33
Figure 10: Availability calculation.....	36
Figure 11: Wired and Wireless communication Graph	38
Figure 12: Reliability block diagrams for wired detector system.....	39
Figure 13: Reliability block diagram for wireless detector system	40
Figure 14: GasSecure SafeWireless	45
Figure 15: End-to-end versus proxy based safety.....	47

List of abbreviations

ACK	Acknowledgment Packet
CAPEX	Capital Expenditure
CCA	Clear Channel Assessment
DiffServ	Differentiated Services
DL	Down Link (from controller to device)
DLL	Data Link Layer
DSN	Distributed Sensor Network
HCF	HART Communication Foundation
IEC	International Electrotechnical Commission
IntServ	Integrated Services
ISA	International Society of Automation
I/O	Input/Output
LR-WPAN	Low-Rate Wireless Personal Area Network
MAC	Medium Access Control Layer
PCDA	Process Control and Data Acquisition
PER	Packet Error Rate
PHY	Physical Layer
PFD	Probability of Failure on Demand
PFH	Probability of Failure per Hour
PRR	Packet Reception Rate
PST	Process Safety Time
QoS	Quality of Service
RF	Radio Frequency
SFF	Safe Failure Fraction
SIL	Safety Integrity Level
SIS	Safety Instrumented System
TDMA	Time Division Multiple Access
UL	Up Link (from device to controller)
WSN	Wireless sensor networks
6LoWPAN	IPv6 over Low power Wireless Personal Area

1 Introduction

1.1 Background

The current report has been developed as part of the PETROMAKS innovation project “*Tools and guidelines for overall barrier management and reduction of major accident risk in the petroleum industry*”, funded by the Norwegian Research Council and the members of the PDS forum¹. The work has mainly been carried out by SINTEF and may therefore not express the views of all the PDS participants.

This project started autumn 2012 and will be running throughout 2015. A main goal of the project is to develop a practical industry guideline for barrier management, covering all relevant lifecycle phases and activities.

As part of this project, one activity is related to considering how new technology may influence the integrity of the barriers. Wireless instrumentation used in safety critical applications has here been selected as a specific case since recent developments are pushing the boundaries of this technology from its current usage area in non-critical monitoring towards safety-critical applications such as fire & gas detection. The frontier of this change is driven by the Norwegian company GasSecure which has developed the world's first wireless hydrocarbon gas detector with SIL2 certification. The wireless gas sensor is currently undergoing technology qualification for use within the petroleum industry.

1.2 Content of report

This report is structured as follows: Section 2 provides an introduction to wireless sensor networks (WSNs), the underlying technology for wireless instrumentation, presenting the history and basic technology enabling the recent development of low-power sensors and actuators with robust and resilient wireless communication. Section 3 gives an overview of the different international standards for WSNs, with special focus on the two specifications specifically targeting the process industries; namely WirelessHART and ISA100.11a. Furthermore, Section 4 summarizes the current status of wireless instrumentation within the oil and gas industry, including the financial and operational drivers for going wireless, along with the technical requirements which must be fulfilled for a successful adoption of this new technology. Moreover, Section 5 covers the use of wireless instrumentation in safety critical systems, using the GasSecure sensor as a case. Finally, a discussion on the consequences of using wireless instrumentation in safety critical systems can be found in Section 6

¹ PDS is a Norwegian acronym for "reliability of safety instrumented systems". For more information about PDS see: www.sintef.no/pds

2 Wireless sensor networks

A wireless sensor network (WSN) can be defined as a collection of distributed, autonomous sensor devices which collaborate to monitor physical or environmental phenomena such as temperature, pressure, vibration, noise, gas and smoke. The sensor devices communicate wirelessly with each other, and a WSN typically consists of numerous sensor devices and a network administrator which collects the sensor data from the network.

2.1 History

Wireless sensor networks (WSNs) are a rather new technology, with its origins tracing back to the early 1980s through the Distributed Sensor Networks (DSNs) program at the Defense Advanced Research Project Agency (DARPA) of the US Department of Defense [1]. DSNs were imagined to consist of many spatially distributed, autonomous and low-cost sensing nodes that collaborated to gather information about their surroundings. However, in the 1980s, the technology was not quite ready for this application. The sensors were too large and expensive and the communication was not yet associated with wireless connectivity.

In the late 1990s, advances in computing, communication and micro-electromechanical technologies caused a shift in DSN research, bringing it closer to achieving the original vision. The "second wave" of DSN activities started in 1998, and it attracted large international involvement and attention. New networking techniques and networked information processing suitable for the dynamic ad-hoc environments found in sensor networks were the initial focus, with the goal of enabling the required complex applications to run on resource-constrained sensors [1]. The sensors themselves also evolved with new technology, reducing both their cost and size. In addition, advances in wireless technology enabled robust and reliable wireless communication ideally suited for wireless distributed sensor networks. DARPA was again the pioneer, leading the efforts of sensor network research. They initiated a research program which provided new insights into ad-hoc networking, dynamic querying and tasking, reprogramming and multi-tasking [1]. At the same time, IEEE started to note the potential of WSNs, and begun work on a specification for low-rate wireless personal area networks.

The work of IEEE was finalized in 2003, when the IEEE 802.15.4 specification [2] was ratified, defining the physical layer (PHY) and medium access control layer (MAC) for Low-Rate Wireless Personal Area Networks (LR-WPAN). The higher layers of the protocol stack are out of scope of the specification. Offering features such as low power, low complexity and low cost, it is ideally suited for WSN applications. With a growing number of solutions based on the IEEE Std. 802.15.4 appearing in the years since its release, it has become the de facto standard for WSNs. The ZigBee specification [3], originally released in 2004, was the first full standard to appear based on the IEEE Std. 802.15.4. ZigBee defines the Network Layer and Application Layer on top of the IEEE Std. 802.15.4 PHY and MAC.

Early research and evaluation of the IEEE Std. 802.15.4 identified several potential issues related to information security, in addition to other minor bugs and errors. A new version of the standard was released in 2006, IEEE Std. 802.15.4-2006 [4], which addressed these shortcomings. The original standard from 2003 is referred to as IEEE Std. 802.15.4-2003, to distinguish the two versions. Shortly after the ratification of IEEE Std. 802.15.4-2006, the ZigBee Alliance released a new version of the ZigBee standard, ZigBee-2006 [5]. The original ZigBee standard is referred to as ZigBee-2004. ZigBee-2006 included improvements for, among other things, addressing issues leading to scalability problems for large networks. However, it is important to note that ZigBee-2006 was still based on IEEE Std. 802.15.4-2003, and not on the new IEEE Std. 802.15.4-2006. Hence the security issues of IEEE Std. 802.15.4-2003 were still present in ZigBee-2006.

In 2007, the HART Communication Foundation (HCF) released the HART Field Communication Protocol Specification, Revision 7.0 [6], which included a definition of a wireless interface to field devices, referred to as WirelessHART. WirelessHART was the first specification to be released which was specifically

designed for process automation applications. With features such as self-healing and self-configuring multi-hop mesh networks, WirelessHART offers a viable wireless alternative for the traditionally wired industrial field instrumentation. WirelessHART was approved by the International Electrotechnical Commission (IEC) as international standard IEC 62591 Ed. 1.0 for wireless communication in process automation [7] in March 2010.

The ZigBee specification was initially designed to address applications within home automation and consumer electronics. A ZigBee network operates on the same, user defined channel throughout its entire lifetime. This makes it susceptible both to interference from other networks operating on the same frequency and to noise from electrical equipment and machinery in the environment. As a result, ZigBee has not been regarded as robust enough for harsh industrial environments [8]. To combat this challenge, the ZigBee Alliance released the ZigBee PRO specification [9] in 2007. ZigBee PRO is specifically aimed at the industrial market, having enhanced security features and a frequency agility concept where the entire network may change its operating channel when faced with large amounts of noise and/or interference. Despite these innovations, ZigBee has not yet been fully adopted by the industry.

Parallel to HCF's work on WirelessHART, the International Society of Automation (ISA) initiated work on a family of standards for wireless systems for industrial automation applications. This resulted in the ratification of the ISA100.11a standard in September 2009 [10]. Like WirelessHART, ISA100.11a aims to provide secure and reliable wireless communication for non-critical monitoring and control applications in the process automation industries. A new version of the ISA100.11a was released in 2011 [11], addressing minor faults and errors in the initial specification.

A third specification addressing wireless communication for the process automation industries, WIA-PA, was accepted by the IEC in 2009 as IEC 62601 [12]. WIA-PA was developed by the Chinese Industrial Wireless Alliance (CIWA) under the urgent requirements of process automation. In 2007, CIWA was established by Shenyang Institute of Automation, along with more than 10 universities, academies, and companies. The scope of WIA-PA is to provide a system architecture and protocol stack for use in industrial monitoring, measurement and control applications. However, at the time of writing, no products supporting WIA-PA are readily available on the market.

In April 2012, the IEEE 802.15.4e [13] was released as an amendment to the IEEE 802.15.4 specification. It provides additional MAC behaviour and frame formats which allow IEEE 802.15.4 devices to support industrial applications such as process control and factory automation. At the time of writing, no devices supporting IEEE 802.15.4e has yet been released.

2.2 Technology

The following section presents some of the components, network topologies and communication protocol capabilities often encountered in WSNs. This information is a restructured and modified version of previously published material by the author [14].

2.2.1 Wireless sensor node

A wireless sensor device consists of several elements, as illustrated in Figure 1.

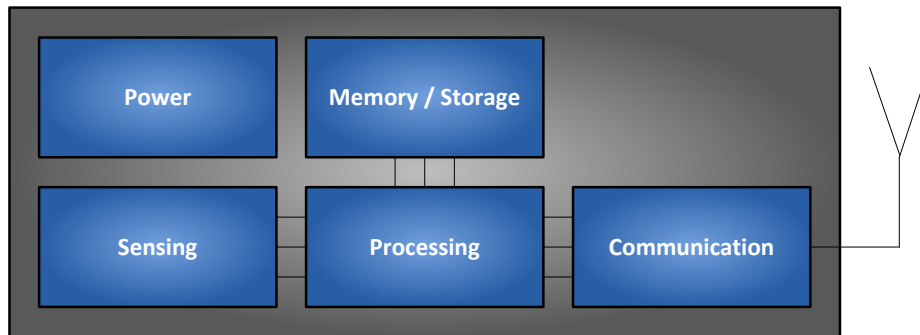

Figure 1: Wireless sensor node

The sensing unit measures a physical phenomenon (e.g. temperature or pressure), and an analogue-to-digital converter quantifies and converts the measurement to the digital representation needed for further processing and communication. The processing unit analyses the sensor data and encapsulates it in data packets according to the communication protocol. The processing unit is also responsible for handling and scheduling the communication. The communication unit provides the wireless interface, and handles transmission and reception of data packets. It consists of an antenna and a Radio-Frequency (RF) transceiver. The memory and storage are used for temporary and permanent storage of firmware, configuration parameters and sensor data. The power unit is normally a battery, and it provides power to all other components of the wireless sensor device.

One of the main challenges of WSNs is to combine long battery lifetime (i.e. low power consumption) while simultaneously supporting complex communication protocols running on low power microcontrollers with limited processing power and resources. The long battery lifetime requirement will normally preclude the use of wireless actuators, and systems with wireless actuation are therefore not considered in this report.

2.2.2 Network topologies

Depending on the communication protocol and the routing capabilities of the network devices, network topologies in a WSN may range from star to (full) mesh. In a star topology, all devices communicate with a central coordinator, as illustrated in Figure 2a. In this setting, the sensor devices are not capable of communicating with each other. In a mesh topology, on the other hand, all devices are capable of communicating with all other devices within radio range, creating the topology shown in Figure 2b. It is also possible to have a combination of a star and mesh topology, called star-mesh. In a star-mesh there is a kernel mesh network created by router devices, and an outer network of sensors connecting to the routers. An example of a star-mesh topology is depicted in Figure 2c.

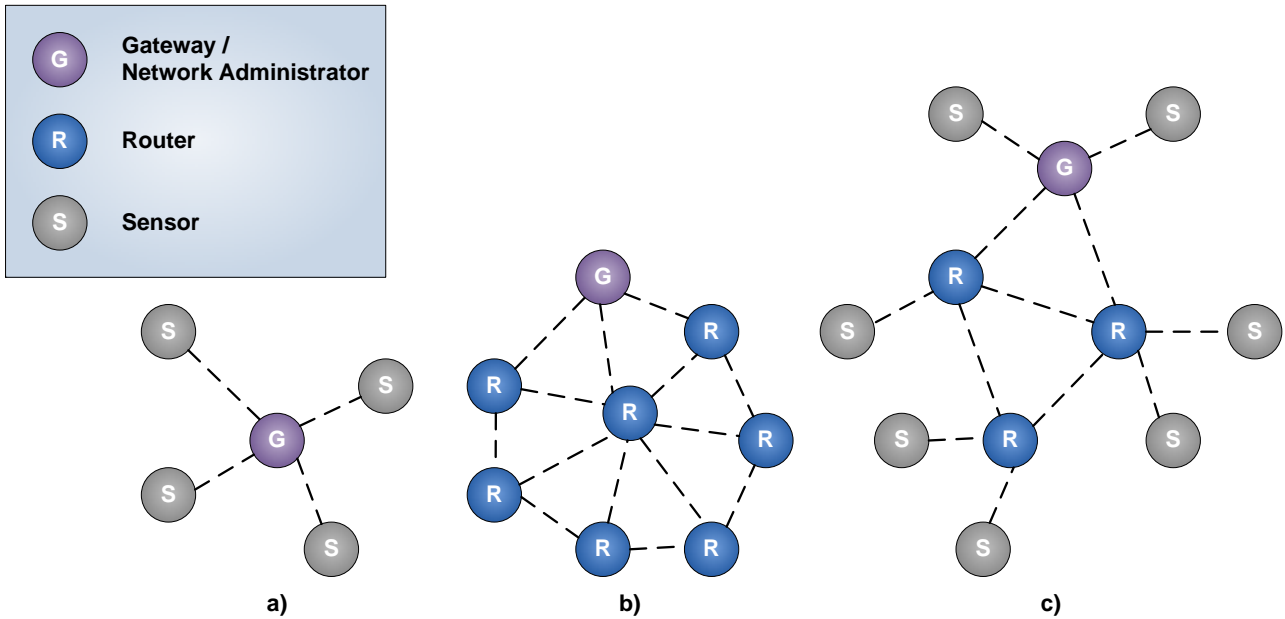

Figure 2: Examples of network topologies: a) star, b) mesh, c) hybrid star-mesh

2.2.3 Routing

Routing can be defined as the process of selecting the best communication paths in a network. In packet switching networks encountered in WSNs, routing algorithms are responsible for directing data packets from their source to their destination, potentially through one or more intermediate nodes. There are two different routing algorithms which are used for routing data packets within WSN; graph and source routing.

A graph route is a list of transmission paths that connect network end points. A network may have multiple, overlapping graphs, and a device may have multiple graphs going through it. An example of graph routing is presented in Figure 3. Here, device A communicates with device F using Graph 1. To send a packet to device F, device A can transmit either via device B or C, which in turn will forward the packet according to their own graph routing configurations. The following routes from A to F are possible using Graph 1: A-B-D-F, A-C-D-F or A-C-E-F. Similarly, to communicate with device D, device A sends packets according to Graph 2.

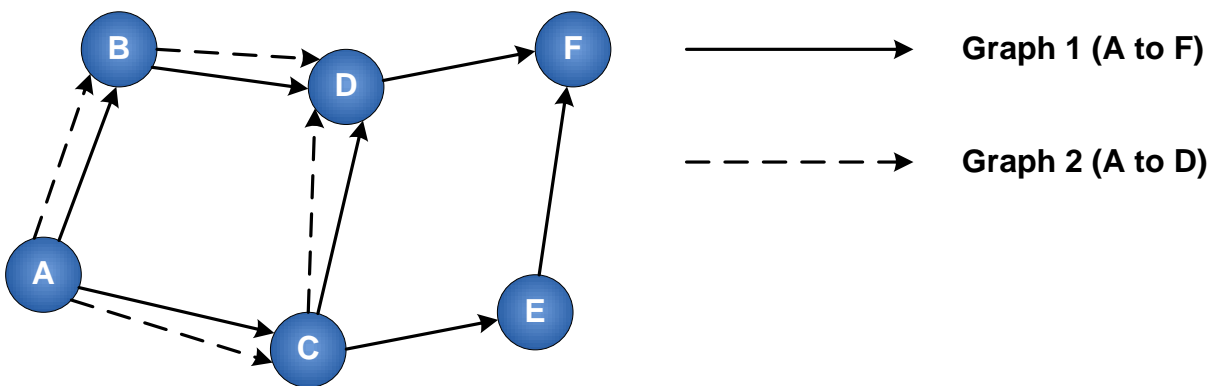

Figure 3: Examples of graph routing

Unlike graph routes, a source route is a single directed route between a source and a destination device, and it defines the specific path a packet must take when travelling from its source to its destination. If any of the links in a source route fails, the packet is lost. This is not the case for graph routes, where each device has multiple associated neighbours to which they may send packets, ensuring redundancy and enhancing reliability compared to source routing.

The routes in a network are configured by the network manager based on periodic health reports from devices indicating the historical quality of the wireless connectivity to their neighbours.

2.2.4 Time-division multiple access and frequency-division multiple access

In industrial WSNs, time-division multiple access (TDMA) is used for channel access. The communication is divided into distinct timeslots with a typical duration of 10 ms. A collection of timeslots forms a superframe which repeats in time throughout the entire lifetime of the network. The term frame is used to separate instances in time of a specific superframe, as illustrated in Figure 4. One superframe must always be enabled, although multiple superframes of variable lengths can coexist in a network. Superframes can be added and removed while the network is operational.

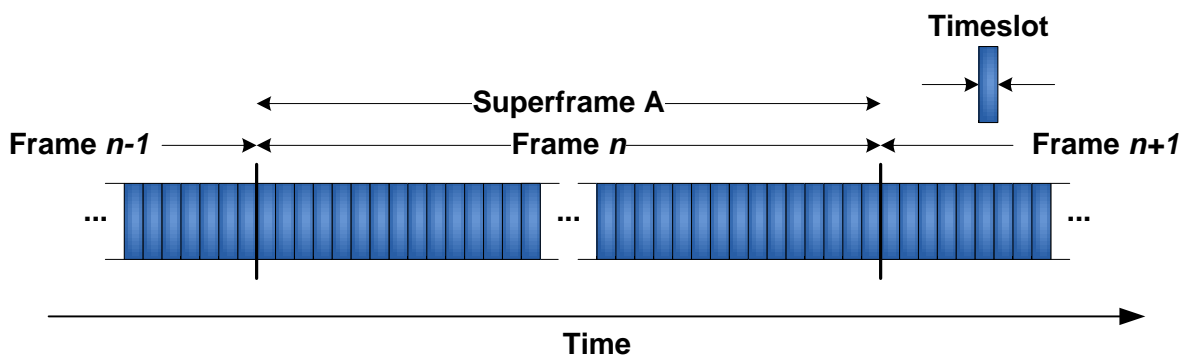

Figure 4: TDMA timeslots, frames and superframes

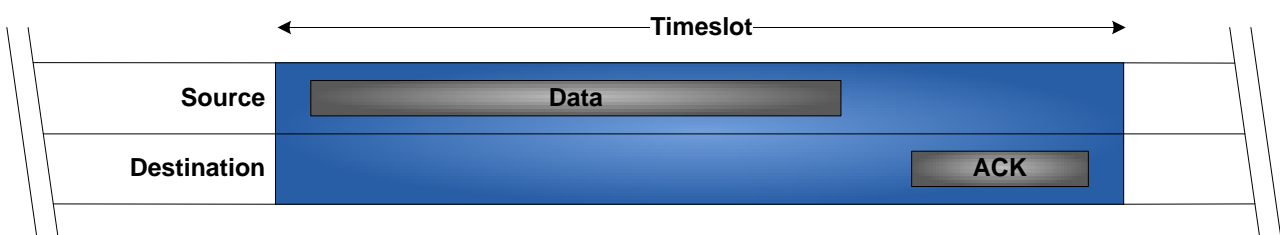

Figure 5: Data transmission and acknowledgment within a timeslot

To supervise the communication within a network, two devices are typically assigned to a timeslot, one as a source (transmitter) and the other as the destination (receiver). An exception to this is broadcast messages where multiple devices are assigned as receivers in the same timeslot. Within a timeslot, the source device may transmit a data packet to the destination device. Upon successful reception of a data packet, the destination device will transmit an acknowledgment packet (ACK) to the source device, as depicted in Figure 5. If the source device fails to receive an ACK, the data packet will be retransmitted in the next available timeslot. Note that an ACK is not transmitted upon reception of a broadcast message.

Combined with these TDMA mechanisms, industrial WSNs also employ frequency hopping. The communication is therefore divided into a two-dimensional matrix consisting of timeslots and frequency channels. A link is thus specified by a superframe, a timeslot offset (relative to the first timeslot of the superframe), and a channel offset. In consecutive superframes, a link will always have the same timeslot offset, while the communication channel will change according to a pseudo-random hop sequence. As an example, for a given link, communication may occur on Channel 19 in timeslot k in frame n of superframe A , and on Channel 13 in timeslot k in frame $n+1$ of the same superframe. Combining TDMA and frequency hopping in this manner allows for multiple devices to transmit data at the same time on different channels without generating intra-network interference. Note however, that a single device may only participate in communication on one channel (link) per timeslot.

2.2.5 Security

To ensure data confidentiality, authenticity and integrity, wireless protocols must implement sufficient security mechanisms and algorithms. However, for WSNs with limited resources (e.g. processing power and memory capacity), traditional security solutions can not necessarily guarantee security requirements in industrial wireless networks [15]. The following list illustrates various security issues that wireless networks are susceptible to:

- **Accidental Association:** Unintentional access to a wireless network by a foreign computer or device.
- **Malicious Association:** Access to a wireless network is obtained by hackers in order to steal user information, passwords or data, or to launch other attacks and install malicious software.
- **Identity Theft:** Hacker which is able to impersonate an authorized device or user by listening to credential traffic.
- **Man-in-the-Middle Attacks:** Hackers gaining access to a network with Malicious Association, and transparently monitor network traffic and/or provide false information and data to other network users.
- **Denial of Service:** A target device or gateway is flooded with bogus protocol messages and data in an attempt to reduce or suspend its responsiveness and ability to perform regular functions. Intentional jamming of a wireless communication channel falls under this category.
- **Network Injection:** Accessing access points / gateways to introduce bogus network configuration commands that may affect routers, switches and intelligent hubs. The network devices may crash, shutdown, restart or even require reprogramming.
- **Byzantine Attack:** Attack where an intruder reprograms a collection of compromised sensors, whereby they send fictitious sensor readings to the control room.
- **Radio Interference:** Interference from other wireless networks operating in the same frequency bands.
- **Noise:** Wireless networks might be negatively influenced by industrial machines and equipment emitting electromagnetic radiation.
- **Solar flares:** The sun occasionally ejects electrons, ions and atoms into space through large and concentrated releases of energy called solar flares. These solar flares produce radiation across all wavelengths of the electromagnetic spectrum, and have historically been known to disturb radio communication and to disable energy networks when targeting the Earth.

The main tasks of the security mechanisms in WSN protocols are to provide protection against the attacks mentioned above by ensuring secure communication between devices, and to provide message authenticity and data confidentiality.

3 International standards

When discussing WSN specifications and solutions, it is helpful to understand the structure of communication protocol stacks. A protocol stack defines a set of layers, where each layer is a collection of related functions. A layer offers services to the layer above it, and uses services from the layer below. The most common communication stack model is the seven-layered OSI-Model [16], illustrated in Figure 6. For WSNs, a simplified version of the OSI model is used, where the Presentation Layer and the Session Layer are not defined. Note that not all WSN standards define the Transport Layer either.

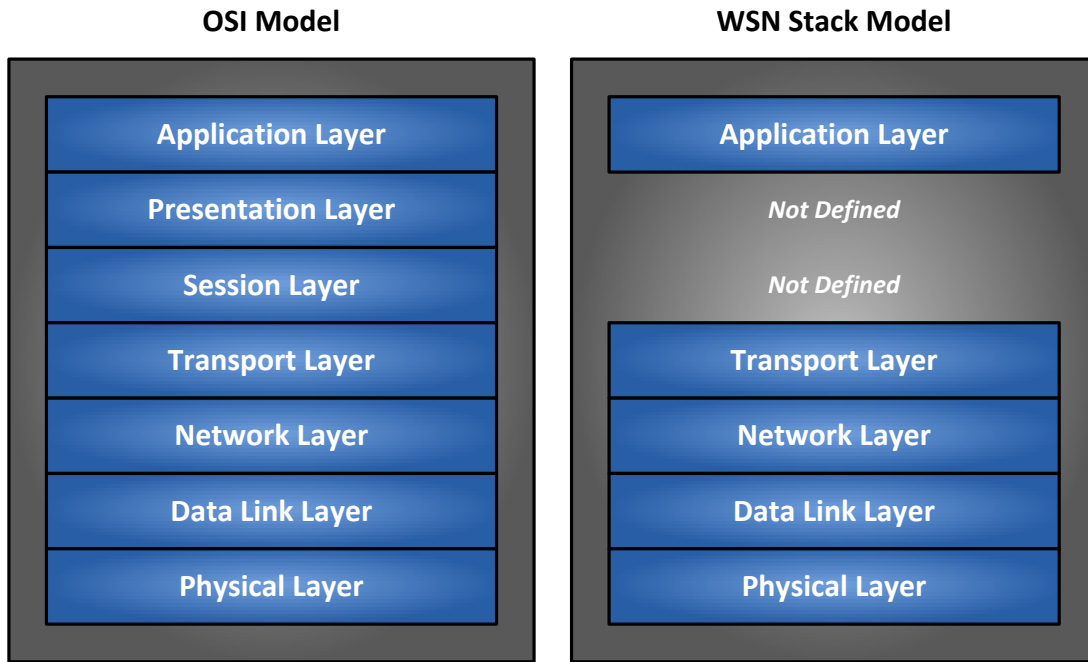

Figure 6: Communication Protocol Stacks

3.1 IEEE 802.15.4

The IEEE Std. 802.15.4 [2] was initially released in 2003 and updated in 2006. The standard comprises four different PHYs, three in the 868/915 MHz band and one in the 2.4 GHz band. 27 channels are defined, numbered from 0-26. Channel 0 is in the 868 MHz band, Channels 1-10 are in the 915 MHz band and Channels 11-26 are in the 2.4 GHz band. In the 2.4 GHz band the channel width is 2 MHz and the channel spacing is 5 MHz. As the 868 MHz (Europe) and 915 MHz (US) bands have limited geographical availability due to various national rules and regulations, most industrial applications use the globally available 2.4 GHz band.

3.2 ZigBee / ZigBee PRO / ZigBee IP

The ZigBee specification [5], initially released in 2004 and updated in 2006 and 2007, is a low rate, low power WSN standard developed by the ZigBee Alliance. The specification defines network and application layers on top of the PHY and MAC layers of the IEEE Std. 802.15.4-2003, and it is primarily targeting smart grid, home automation and consumer electronics applications. Since the ZigBee specification uses the PHY and MAC layers of the IEEE Std. 802.15.4, they have the same modulation techniques, bandwidth and channel configurations.

A ZigBee network operates on the same, user defined channel throughout its entire lifetime. This makes it susceptible both to interference from other networks operating on the same frequency and to noise from other sources in the environment. As a result, ZigBee has not been regarded as robust enough for harsh industrial environments [17]. To combat this challenge, the ZigBee Alliance released the ZigBee PRO specification [9] in 2007 in the shape of what is defined as another feature set. ZigBee PRO is specifically aimed at the industrial market, having enhanced security features and a *frequency agility* concept where the entire network may change its operating channel when faced with large amounts of noise and/or interference. Despite these innovations, ZigBee has not yet been fully adopted by the industry.

The ZigBee Alliance announced in April 2009 that it will incorporate standards from the Internet Engineering Task Force (IETF) into future ZigBee releases, thereby opening up for IP-based communication in ZigBee networks. Of special interest for the ZigBee Alliance is the 6LoWPAN working group which has created a Request for Comments (RFC4944) investigating the transmission of IPv6 packets over IEEE Std. 802.15.4 networks. This work resulted in the ratification of the ZigBee IP specification in February 2013 [18].

3.3 6LoWPAN

6LoWPAN (IPv6 over Low power Wireless Personal Area Networks) specifies the transmission of IPv6 packets on IEEE 802.15.4 networks. The 6LoWPAN overview, assumptions, problem statement and goals are defined in RFC4919 “*IPv6 over Low-Power Wireless Personal Area Networks (6LoWPANs): Overview, Assumptions, Problem Statement, and Goals*” [19], while RFC4944 “*Transmission of IPv6 Packets over IEEE 802.15.4 Networks*” [20] describes the frame format for transmission of IPv6 packets and the method of forming IPv6 link-local addresses and auto-configured addresses on IEEE 802.15.4 networks. A simple header compression scheme for IEEE 802.15.4 mesh networks is also defined.

The 6LoWPAN definition may be used as a standalone specification for WSNs, but it is more often found as an integrated part of the network layer of other specifications, e.g. ISA100.11a.

3.4 WirelessHART

WirelessHART is a part of the HART Field Communication Specification, Revision 7.0 [6], which was ratified in September 2007. WirelessHART enables wireless transmission of HART messages, and was the first standard to be released which specifically targets industrial applications. WirelessHART was approved as IEC standard 62591 in 2010.

WirelessHART is based on the IEEE Std. 802.15.4 PHY and MAC, although the MAC has been modified to allow for frequency hopping. Furthermore, WirelessHART only operates in the 2.4 GHz band, which allows for global availability. TDMA with frequency hopping is used as channel access method, and with a full mesh network topology, WirelessHART offers self-configuring and self-healing multi-hop communication.

3.5 ISA100.11a

The ISA100 standards committee of ISA aims to deliver a family of standards for wireless systems for industrial automation. ISA100.11a [11] was the first standard to emerge, being ratified in 2009 and updated in 2011. ISA100.11a is designed for secure and reliable wireless communication for non-critical monitoring and control applications. Critical applications are planned to be addressed in later releases of the standard.

ISA100.11a is based on the IEEE Std. 802.15.4 PHY and MAC, but the MAC has been adopted to allow for frequency hopping and extended security mechanisms. ISA100.11a only defines operation in the 2.4 GHz band.

TDMA with frequency hopping is used as the channel access mechanism. ISA100.11a supports both routing and non-routing devices, so network topologies can be either star, star-mesh or full mesh depending on the configuration and capabilities of the devices in the network.

An ISA100.11a network is able to carry multiple fieldbus protocols, such as Foundation Fieldbus, PROFIBUS and HART. There is also integrated support for IPv6 traffic and routing in the network layer.

3.6 WIA-PA

WIA-PA [12] is a specification for system architecture and communication protocol. It is built upon the IEEE 802.15.4 PHY and MAC. WIA-PA was developed by the Chinese Industrial Wireless Alliance (CIWA) under the urgent requirements of the process automation industries. WIA-PA became a Public Available Specification (PAS) of IEC via IEC voting on October 31, 2008 with number IEC/PAS 62601. The WIA-PA network topology is formed using cluster heads as essential device types. Each cluster head forms a local star network. Only devices belonging to the specific cluster head can become cluster members. The cluster members are typically field devices, i.e. sensors and actuators. Field devices are solely input/output devices, with no routing capability. As a consequence, network topology is limited to a star-mesh configuration. Redundancy is achieved at the cluster head, by adding a redundant cluster head. In this manner, the local star network as a whole benefits from redundancy. However, there is no alternative route for broken links from field device to cluster head.

At present, we are not aware of any industrial versions of wireless instrumentation employing WIA-PA.

3.7 WirelessHART vs ISA100.11a

Although WirelessHART and ISA100.11a have many more similarities than differences, there are still some key technical properties that are different in the two standards. In the following sections, a breakdown of some of the most prominent features that separate WirelessHART and ISA100.11a are presented.

3.7.1 Flexibility

WirelessHART and ISA100.11a are inherently different regarding the operational flexibility and configuration possibilities that the specifications allow for. WirelessHART is a rather "simple" specification with very few optional or configurable parameters. ISA100.11a on the other hand, is a complex and comprehensive specification with many configurable and optional parameters found in different stack layers. These features are both strengths and weaknesses depending on the specific needs and requirements of the target applications and usage scenarios.

The strict and limited approach of WirelessHART ensures that practically all WirelessHART devices will have identical behavior, regardless of design and implementation choices made by the equipment providers. This should easily facilitate interoperability between multiple vendors, as all products adhering to the standard should be equal. This naturally comes at the cost of a lack of possibility to adapt and tailor the device and network behavior to specific application requirements.

The wide range of available optional and configurable parameters in ISA100.11a allows for great flexibility for adapting network behavior to various application requirements. However, it may lead to interoperability issues if different vendors choose to implement different features of the standard. To combat this, ISA100.11a must define application profiles. A profile is a cross-layer specification that defines which options are mandatory in the different protocol layers. Although profile definitions help with possible interoperability issues, it still requires extensive compliance testing and verification to achieve full vendor flexibility.

3.7.2 Protocol support

WirelessHART is a wireless extension of the wired HART Field Communication Protocol Specification, and is naturally confined to using the command-based HART protocol for message exchange. All information and data in a WirelessHART network must be transmitted in the shape of HART Commands.

The ISA100.11a application layer is object oriented, and implements tunneling features that allow devices to encapsulate foreign protocols and transport them through the network. Although successful tunneling of protocols depends upon how well ISA100.11a meets the technical requirements of the foreign protocol, it still opens up the possibility of transferring a multitude of wired protocols over an ISA100.11a network.

3.7.3 Coexistence

Since WirelessHART and ISA100.11a operates in the popular 2.4 GHz band, they are likely to be subjected to interference from other wireless networks operating in the same frequency band. In recent years, IEEE 802.11-based infrastructure has become commonplace in many process plants and facilities, and it is expected that most wireless instrumentation deployments will share the frequency spectrum with IEEE 802.11-based access points and mobile devices. Practical experiments have shown that the performance of IEEE Std. 802.15.4-based networks will be degraded when coexisting with IEEE 802.11 networks [21], and since WirelessHART and ISA100.11a inherits their physical layer from IEEE Std. 802.15.4, they will be subjected to such interference as well.

To mitigate the effects of interference, wireless protocols may employ various coexistence mechanisms. In WirelessHART and ISA100.11a, clear channel assessment (CCA) and channel blacklisting are the weapons of choice to combat the degrading influence from other wireless networks. However, the two standards have chosen to implement the two features in slightly different ways. WirelessHART employs manual channel blacklisting, where a network operator must manually configure which channels are available and which channels are blocked. ISA100.11a has an adaptive blacklisting mechanism, where each device in a network may autonomously blacklist channels which suffer from noise and/or interference. Furthermore, ISA100.11a defines four different CCA modes, where modes 1-3 are defined by IEEE Std. 802.15.4:

0. **No CCA:** CCA is disabled, and not conducted prior to transmission.
1. **Energy Above Threshold:** CCA reports a busy medium upon detecting any energy above a configurable threshold.
2. **Carrier Sense Only:** CCA reports a busy medium if a signal compliant with IEEE Std. 802.15.4 PHY modulation and spreading characteristics is detected.
3. **Carrier Sense with Energy Above Threshold:** CCA reports a busy medium using a logical AND/OR combination of Modes 1 and 2.

WirelessHART on the other hand, has fixed its CCA mechanism to mode 2.

With the correct configuration, ISA100.11a should be somewhat better equipped to handle coexistence with IEEE 802.11 networks. While WirelessHART only listen to activity from other IEEE Std. 802.15.4 networks, ISA100.11a will by employing either CCA modes 1 or 3 report a busy medium if any energy above a threshold is detected. If there is activity from a nearby IEEE 802.11 access point or client, the ISA100.11a device will back off and delay its transmission to the next available timeslot. This will naturally result in increased latency, but no power is wasted trying to transmit a message that will most likely not be received correctly by the destination device. In addition, the adaptive channel blacklisting mechanism of ISA100.11a can dynamically remove this problem completely by not using channels which show high IEEE 802.11 activity.

3.7.4 Quality of Service

Although Quality of Service (QoS) is a term with various meanings and interpretations depending on the context, it can here be accepted as a measure of the service quality that a network offers to applications and/or users [22]. With QoS comes the ability to control the resource sharing of a network by giving different priorities to various applications and data packets depending on their requirements. Higher performance levels can then be provided to specific applications and data packets through a set of measurable service parameters such as latency, jitter, packet loss, reliability and availability [23].

Support for QoS in wired networks is generally obtained by over-provisioning and/or traffic engineering [22]. With over-provisioning, extra resources are added to the network so that it is able to provide satisfactory services to all applications. As all users are served at the same service class, over-provisioning may become unpredictable during peak traffic. For resource-constrained WSNs, over-provisioning is not an ideal QoS method as the network often does not have the capacity to provide the required resources. In traffic engineering, users and applications are assigned a different priority through a set of defined service classes. This method is also called service differentiation, and it is a widely adopted scheme for both wired and wireless networks to provide QoS guarantees [23]. For traditional wired computer networks there are two main models for service differentiation; integrated services (IntServ) [24] and differentiated services (DiffServ) [25]. The IntServ model maintains service on a per-flow basis, while the DiffServ model maintains service on a per-packet basis. For the packet-based nature of WSNs, DiffServ is the best suited mechanism for service differentiation [26]. In the DiffServ model, the source devices know the criticality of the data packets it is sending, and this criticality is translated into predefined priority levels. Other devices in the network also select the appropriate service level for data packets based on their priority.

WirelessHART defines four different priority levels on the DLL [6]:

- **Command** (highest priority). The Command priority is used for packets containing network-related diagnostics, configuration or control information.
- **Process Data**. Packets containing either process data or network statistics shall be classified as Process Data priority. Only the control of the network is more important than the delivery of sensor data measurements from field transmitters or set-point information to actuators.
- **Normal**. If a DLPDU does not meet the criteria for any of the other three priority levels (Command, Process Data or Alarm), it shall be classified with Normal priority.
- **Alarm** (lowest priority). Packets containing only network alarm and network event information shall have a priority of Alarm.

These priority levels are primarily used for flow control and to mitigate potential network congestion points in the event of either a process upset or noise/interference deteriorating the RF channel(s). With the abovementioned mechanisms, network management packets have full priority while propagated through the network, allowing the network manager to keep the network operational. Network-induced alarms have a restricted flow through the network, ensuring that alarm floods do not disrupt or hinder the network operation. All other network traffic flows through the network as bandwidth and internal buffer spaces on the devices allows. Unfortunately there is only one priority level reserved for process data, which means that all sensors and/or actuators in a WirelessHART network share the same priority level, regardless of the requirements and criticality of the application they are serving.

ISA100.11a uses contracts to define the setup and requirement of communication between two devices in a network. A contract is an agreement between the system manager and a device in the network that involves the allocation of network resources by the system manager to support the communication requirements of the device. All contracts are unidirectional, and they are established by the system manager upon reception of a contract request. ISA100.11a supports two priority levels, contract priority and message priority. The

contract priority is the base priority for all messages sent using a specific contract. Four contract priorities are supported [11]:

- **Network control** (highest priority): May be used for critical management of the network by the system manager.
- **Real time buffer**: May be used for periodic communications in which the message buffer is overwritten whenever a newer message is generated.
- **Real time sequential**: May be used for applications such as voice or video that need sequential delivery of messages.
- **Best effort queued** (lowest priority): May be used for client-server communications.

The message priority establishes priority within a contract using two messages priorities: high and low. The contract priority is specified by the application, during contract establishment time, in its contract request. It may be used by the system manager to establish preferred routes for high priority contracts and for load balancing the network. The combined contract and message priority is used to resolve contention for scarce resources when these messages are forwarded through the network.

3.7.5 Security

Both WirelessHART and ISA100.11a rely on a centralized security manager for the authentication of new devices, and the generation and management of security keys throughout the lifetime of the network. This means that the loss of the security manager will cause the loss of security mechanisms in the network. New releases of WirelessHART and ISA100.11a networks are combating this issue by offering redundant network and security manager solutions with automatic and transparent handover from the primary to the secondary system in case of failure.

In WirelessHART, all security features are mandatory, while ISA100.11a defines many security mechanisms as optional. Considering that security algorithms require additional processing time, memory, and power, making them mandatory means that devices that may not require strict security policies cannot disable them to achieve benefits such as extended battery life. On the other hand, the ISA100.11a concept of having optional security features may be a security threat in itself, and also an issue when it comes to interoperability. Vendors might not choose to implement the full security suite, and different vendors might choose to implement different parts of the optional security features.

3.7.6 Suitability for safety applications

In safety applications, reliability and timeliness are the main requirements for the communication between sensors and the safety system. As opposed to control-loops, rapid update rates are normally not required, but safety communication must have mechanisms which ensure that data packets arrive within a specific deadline. For most safety systems, a query-based data delivery model is used where the safety controller periodically requests data from the sensors.

Safety systems in the process industries are subject to comply with a certain Safety Integrity Levels (SIL). The standard IEC 61508 [27] defines SIL from a set of requirements that both accomplish hardware safety integrity and system safety integrity. There are four SIL levels (1-4), where SIL 4 is defined as the most dependable and SIL 1 as the least. Neither WirelessHART nor ISA100.11a directly supports the necessary certified SIL safety mechanisms as an integrated part of their specifications. A workaround for this is to use an already established and certified end-to-end communication protocol, such as PROFIsafe [28], which is designed to be implemented on top of the PROFINet fieldbus [29].

The recent development of the world's first wireless hydrocarbon gas detection system has proven that it is possible to achieve SIL2 end-to-end communication between a safety controller and a wireless sensor by tunnelling PROFIsafe over ISA100.11a [30]. For WirelessHART on the other hand, limitations in currently available HART commands at the application layer, makes it impossible to implement the tunnelling mechanisms needed for full PROFIsafe support. PROFIsafe over WirelessHART will thus not be available before a potential modification and new release of the HART Field Communication Protocol Specification is available.

A more in-depth analysis of the suitability of WirelessHART and ISA100.11a for safety applications is presented in chapter 5.

4 Wireless instrumentation in the oil and gas industry

Wireless instrumentation is defined as the merger of wireless sensor network (WSN) technologies with process automation disciplines. A wireless field instrument is typically a traditional, formerly wired, sensor or actuator equipped with an additional radio transmitter, antenna and power supply (battery). The instrument parts (i.e. sensor or actuator elements) are the same as for a wired instrument, and they have the same measurement performance characteristics and accuracies.

For process automation, the advent of wireless instrumentation represents the third stage in technology development for field device communication technology. Historically, each field instrument required a dedicated cable going from the device and directly to the control systems, as depicted in "Phase 1" in Figure 7. Due to the sheer amount of cabling necessary for this solution, automation vendors started looking into fieldbus technologies in the late 1980s. With this technology, a single wire runs from the controller to the field, and the field devices connect to the fieldbus network with a dedicated (but much shorter) cable, as illustrated in "Phase 2" in Figure 7. Finally, with the recent introduction of wireless instrumentation, field devices no longer require any cabling, but rather connect wirelessly to wireless access points. The wireless networks are configured, managed and controlled by a network manager, which typically is a separate device connected to the backbone plant (fieldbus) network, as shown in "Phase 3" in Figure 7.

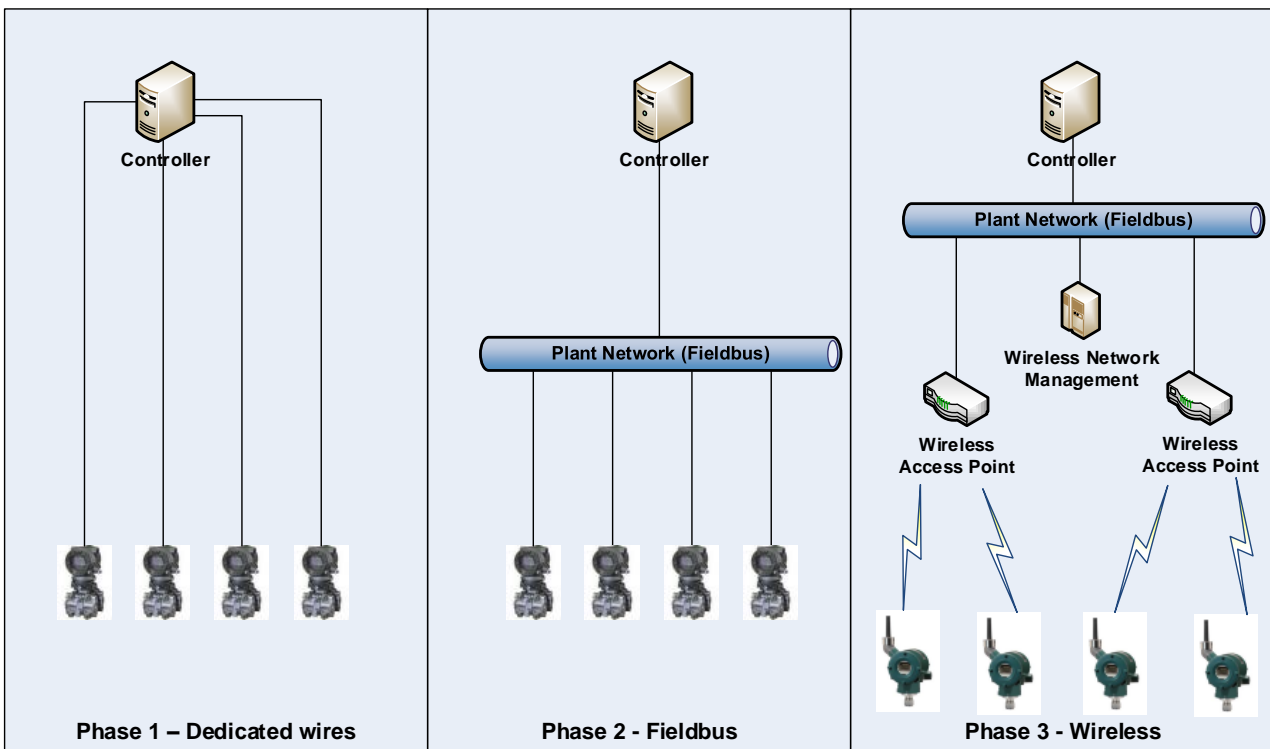

Figure 7: Evolution of field device communication technologies – simplified architecture

The performance requirements of an industrial field instrument depend upon the nature and criticality of the application it is serving. NAMUR, a user association for automation technologies in the process industries, defines the following three applications classes for wireless instrumentation in their recommendation document NAMUR NE 124 "Wireless Automation Requirements" [31]:

- **Application Class A** – Functional Safety
- **Application Class B** – Process Management and Control
- **Application Class C** – Display and Monitoring

Similarly, the International Society of Automation (ISA) has defined six usage classes for wireless instrumentation through their work on the ISA100.11a specification for wireless field devices [11]:

- **Application Class 0** – Emergency Action
- **Application Class 1** – Closed-loop Regulatory Control
- **Application Class 2** – Closed-loop Supervisory Control
- **Application Class 3** – Open Loop Control
- **Application Class 4** – Alerting and Flagging
- **Application Class 5** – Logging and Downloading/Uploading

A mapping between the NAMUR and the ISA application classes is shown in Figure 8. For simplicity, the three NAMUR application classes will be used, referred to as monitoring (C), control (B) and safety (A), respectively.

Application	NAMUR	ISA
Safety	Class A Functional Safety	Class 0 Emergency Action
Control	Class B Process Management and Control	Class 1 Closed-Loop Regulatory Control
		Class 2 Closed-Loop Supervisory Control
		Class 3 Open-Loop Control
Monitoring	Class C Display and Monitoring	Class 4 Alerting and Flagging
		Class 5 Logging and Downloading/Uploading

Figure 8: Field instrumentation application areas and usage classes

The following section presents the financial and operational drivers, technical requirements and the current status for wireless instrumentation in oil and gas. This information is a restructured and modified version of previously published material by the author [14].

4.1 Financial and operational drivers

The financial and operational drivers for wireless instrumentation in the oil and gas industry can be divided into three categories; Greenfield (new facilities), Brownfield (existing facilities) and general.

4.1.1 Greenfield

As the discovery rate of larger oil fields is decreasing rapidly, future developments (Greenfield) need to focus more and more on cost-effective solutions for marginal fields. To achieve an acceptable break-even, many of these production facilities are planned as limited-, or even unmanned facilities. At a marginal field, the production process is more often subject to changes compared to a larger field. A change in the production process may require a change in instrumentation. The flexibility that is provided by wireless instrumentation opens for the planning of dynamic production environments to a much larger degree compared to traditional plant designs with wired instruments.

For Greenfield projects in general, CAPEX (capital expenditure) related to engineering, commissioning and installation represent the major cost savings for wireless instrumentation through the elimination of local field cable and associated field-run cable trays to local remote-I/O cabinets.

The number of instruments in a wireless network installed in a traditional offshore platform environment will be influenced both by the layout of the facility and by the limitation of the technology. A wireless network comprises field instruments (wireless sensors) and a reception point, commonly referred to as the wireless gateway. The number of wireless instruments per gateway will depend on:

- Update rate per wireless instrument; a fast update rate will occupy more time slots in the fixed-length superframe than a slow update rate (see section 2.2), thus reducing the maximum number of devices in the network.
- The physical environment. For example, radio transmission is not possible between neighbouring spaces that are shielded from each other by metal partitions, since a metal partition is an effective RF shield.

It is possible to calculate estimated cost savings for wireless instrumentation networks, assuming a network with e.g. 30 wireless instruments per gateway. The cost estimate includes the following parameters:

- Cost savings related to cable and cable tray installations
- Reduced costs due to no need for circuit drawings
- Added cost for the wireless instrument due to an estimated 30% higher purchase cost compared to the equivalent wired version
- Gateway cost (shared by 30 wireless instruments)

By using typical vendor prices, and cost estimates on work load and hours from former Statoil projects, the total cost saving per wireless instrument is approximately USD 3,300. Note that the cost saving per instrument will increase with an increased number of wireless sensors per gateway, and vice versa [14].

For offshore facilities, weight savings is also a preferred advantage introduced by wireless instrumentation. In addition to the facilities' total weight, logistics and freight weights from onshore supply bases to offshore facilities also affect the weight budget. The main contributions to weight savings for wireless instrumentation comes from the elimination of cabling, cable trays, junction boxes, I/O cabinets and similar. A weight budget estimate carried out by Statoil takes into account the following parameters:

- Weight savings related to cable and cable trays, including supporting installations
- Added weight from cabling, including trays and support for the wireless gateway
- Added weight from wireless gateway

For Greenfield projects, calculations performed by Statoil show that the net weight saving per wireless instrument is approximately 31 kg. The base for the calculations is again a wireless network with 30 wireless instruments per gateway, and the weight saving per instrument will increase with an increased number of wireless sensors per gateway, and vice versa.

4.1.2 Brownfield

In modification projects (Brownfield), it is assumed that cost and weight savings will be even higher than for Greenfield. The added value from wireless instrumentation in Brownfield is due to:

- Existing installations do not have the remote I/O architecture required to support additional instrumentation. For this reason, installing supplementary wired instrumentation will require pulling cables all the way from instrument to local equipment room
- Pulling cables to local equipment room will in most cases require junction boxes on the way
- Terminating the signal in local equipment room will require marshalling cabinets

The savings will vary among installations as a result of:

- Distance between instrument and local equipment room
- Spare capacity on cable trays
- Spare capacity in junction boxes
- Spare I/O channels
- Size of planned wireless network, i.e. more instruments per gateway equals a lower cost per instrument

For typical monitoring instruments (pressure, temperature, etc), cost savings are estimated to 2-3 times higher compared to Greenfield projects with remote I/O, i.e. in the area of USD 6,600 to USD 9,900. For vibration monitoring instruments, the cost savings are estimated to be somewhat higher.

4.1.3 General

In the above sections on Greenfield and Brownfield considerations, cost savings and weight savings have been presented as the major drivers for implementing wireless instrumentation in the oil & gas industry. However, there are additional drivers and motivational factors for going wireless, including:

- Simplified upgrades and/or replacements due to reduction of time and complexity
- Easy installation of temporary instrumentation, e.g. added monitoring capability in a part of the process plant during special conditions
- A wireless infrastructure allows for mobile instrumentation, for example portable field instruments used during maintenance and modification tasks

Practical experience shows that for existing installations (Brownfield), the process of taking the initial decision to install wireless instrumentation is subject to most assessments and discussions, and thus becomes the most time consuming part of the process. Once the wireless instrumentation infrastructure is established, new application areas and new field instruments rapidly emerge. A good example is Statoil's Gullfaks field, which back in 2007 started with one wireless sensor network serving 13 wireless temperature transmitters at

Gullfaks A. Today, the three Gullfaks facilities (A, B and C) have several wireless sensor networks serving about 140 temperature and pressure transmitters, used for different monitoring applications (Class C). To date, the networks have been performing adequately, providing the required sensor data in a reliable and timely manner.

New development projects should plan with a wireless strategy in mind. Even though development projects traditionally rely on well proven technology, this is also the case for instrumentation. However, the time has definitely come to offer wireless technology the attention it deserves in the planning process. Although at the planning stage all application areas or possibilities of wireless technology may not be obvious, designing the plant with a strategy for wireless instrumentation and also preparing for a wireless infrastructure should be a part of the design specification.

4.2 Requirements

The requirements for wireless instrumentation in the oil & gas industry can be divided into two categories; technical requirements which are not application depended and apply to all wireless instrumentation, and application specific requirements related to instrument usage classes. In addition there are general operational considerations which must be addressed in order to achieve successful deployment of wireless instrumentation in process plants.

4.2.1 Technical requirements

The following technical requirements for wireless instrumentation have been established by the oil and gas industry, regardless of application class.

Unlicensed frequency bands

The radio spectrum is a limited natural resource, and as a result, the frequency band usage is strongly regulated by the authorities. Most frequencies are licensed for specific applications and technologies, but there are still some portions of the frequency bands which are open for free, unlicensed operation. These bands are called ISM-bands (industrial, scientific and medical), and their availability varies by country and region.

The most common ISM-band for short-range wireless communication is the 2.4 GHz band, which has the benefit of being globally available.

Friendly coexistence with other wireless solutions

Wireless technologies are becoming more commonplace, even in industrial facilities. When two or more wireless systems are deployed within radio range of each other, it is imperative that they are capable of friendly coexistence. This means that neither system should suffer critical performance degradation during operation.

Most wireless instrumentation solutions operate in the globally available 2.4 GHz band, which is also occupied by the popular IEEE 802.11-based wireless local area networks (also known as Wi-Fi). The widespread adoption of Wi-Fi has also reached the process industries, and it is expected that most wireless instrumentation deployments will be in an area that is under influence from a nearby Wi-Fi access point.

Standardized and open solutions

Standardized and open communication protocols provide the industry with the flexibility and freedom to choose between multiple vendors while having guaranteed interoperability. Standardized solutions also have the added benefit of longer lifespans for component availability and support compared to proprietary solutions, while at the same time preventing commitment to a single supplier.

Protection from cyber-attacks and threats

Wireless instruments transmit information over the air, which make them more vulnerable to eavesdropping and other security breaches than their wired counterparts. To ensure data confidentiality, authenticity and integrity, the wireless protocols must implement sufficient security mechanisms and algorithms to prevent unintentional and malicious threats and attacks (see section 2.2.5 for more information on security).

Quantifiable network performance

The performance of wireless communication networks is susceptible to environmental changes in the deployment area. Factors such as mobile equipment and personnel, electromagnetic noise and interference from machinery, interference from other wireless systems, variations in temperature and humidity, and weather (e.g. rain and snow) might influence the quality of a wireless communication link. It is therefore important to be able to quantify within reasonable accuracy the expected and operational performance with regards to availability and reliability of wireless solutions.

Specific requirements for the network performance parameters will vary according to the usage class. Typical measurement parameters for quantifying the network performance are:

- **Latency.** Latency should be defined as the end to end delay of data delivery, measured from the sampling instant of a sensor till the sensor data is received at the data consumer (typically the control room software). As most wireless instrumentation deployments have a wired connection from the wireless gateway to the control room, the latency should include the whole communication chain, i.e. starting from the originating sensor, through the wireless network and to the gateway, and over the wired fieldbus to the final application. The latency from the wireless transmission will as such only be a part of the total latency, although it should be possible to measure and report the specific latency for each data packet traversing the wireless network.
- **Packet Error Rate (PER).** The packet error rate (PER) is the percentage of packages which are lost in transmission. PER is registered by the transmitting device when an ACK is not received from the destination device, and it is measured on a link to link basis. PER is used as a quality measure for links, and is the foundation for the self-healing and self-configuring capabilities of WSNs. Links which suffer from high PER over a period of time will be reported as bad, and the routing protocols will be updated in order to reduce their usage.
- **Packet Reception Rate (PRR).** The packet reception rate (PRR) is defined as the percentage of data packets which reach their final destination in a timely manner, i.e. within a certain time deadline. It is worth noting that in WSNs it is possible to have a high PRR even in networks which suffer from high PER, due to the fact that lost packets are retransmitted, possible over different routes. (see Chapter 5.4)

4.2.2 Application specific requirements

The following requirements apply only to the specific application class for wireless instrumentation.

Monitoring applications (Class C)

Monitoring applications includes tasks which, by definition, are not of any immediate operational consequence, nor affect plant safety in any regard. As a result, the network performance requirements for wireless instrumentation applied in monitoring applications are quite relaxed. However, it is still of interest to maintain a certain level of service quality in order for the application to be of any benefit. To maintain a proper data update and application value, it should be expected that wireless instrumentation for monitoring applications to have a high PRR (~99%), and a latency level which is not too high compared to the measurement rate.

Control applications (Class B)

In control applications, the main challenge is to be able to provide sensor and actuator data in a timely and regular manner. Latency should be kept as low as possible, and it must naturally be relative to the sampling rate of the process. In addition to low latency, it is of high importance to have low jitter (defined as the variance of the latency of consecutive data updates), as it is challenging to design control algorithms which are capable of handling aperiodic reception of sensor data. To achieve low latency and jitter, it is recommended to implement proper fieldbus interfaces (e.g. PROFIBUS or Foundation Fieldbus) on the wired side of the wireless gateway and on the instrumentation backbone networks.

Another advantage, if not a strict requirement, for control applications is to have a common timing domain for all components in the system. This means that the clocks of wireless sensors and actuators and the wireless gateway should be synchronized with the clocks of the controllers and control system. Propagating time information through the wireless network should be possible, as a clock accuracy of 1 ms is already required for all wireless devices in order for the TDMA timeslot structure to work properly according to today's wireless standards.

Safety applications (Class A)

In safety applications, the main challenges are found in reliability and timeliness for the communication. As opposed to for example control loops, rapid update rates (in the millisecond range) are normally not the important issue. On the contrary, safety applications require mechanisms that ensure that data packets arrive at the designated destination within a well-defined timeout window. For most safety systems continuous monitoring is required, and in case a sensor reading is above a specified threshold value, a well-defined response to the control system is required.

Safety instrumented systems in the oil & gas industry are subject to comply with a certain Safety Integrity Levels (SIL). The standard IEC 61508 [33] defines SIL from a set of requirements that both accomplish hardware safety integrity and system safety integrity. There are four SIL levels (1-4), where SIL 4 is defined as the most dependable and SIL 1 as the least.

4.2.3 Operational considerations

For a successful deployment of wireless instrumentation, the following operational considerations must be adequately addressed:

Battery lifetime

The elimination of cables is one of the main benefits and motivational drivers for wireless instrumentation. Unfortunately, this means that the power needed to operate the wireless instruments must originate from a local power source, typically a battery. It is also possible for the devices to harvest and scavenge energy from the environment (e.g. through harvesting energy from the sun, vibration, temperature fluctuations and so on), but currently available energy harvesting technologies have some limitations in the amount of energy it is possible to generate.

The battery lifetime of a wireless instrument depends on the update rate of the sensor measurements. With current solutions, a battery lifetime of 5-10 years can be achieved with update rates at 15 seconds or more. For the fastest applications with an update rate of 1 second, the battery lifetime is somewhere between 6 months to 1 year, depending on the manufacturer. The battery lifetime is also affected by ambient weather conditions, where low temperatures decrease battery capacity while higher temperatures increase the capacity. The standard rating for battery capacity is at room temperature, defined as 25°C / 77°F.

The battery packs for wireless instrumentation are designed to be replaceable in the field, and have the same EX-classification as the wireless instruments.

Redundancy

The wireless gateway represents a single point of failure. For most industrial applications, it is preferable with redundant gateway systems providing automatic fail-over in the case of loss of one gateway. For control and safety systems this should be an absolute requirement. It is preferable with gateway systems that integrate directly with the PCDA (Process Control and Data Acquisition) system, for example in the form of CPU modules that fits directly into the controller node. This way, only the radio module or antenna needs to be installed in the process area. For hazardous environments, such architecture is preferred because it simplifies ATEX issues for the wireless gateway. “All-in-one” gateway solutions has proved to be difficult to design in intrinsic safe versions according to ATEX zone 1 requirements, due to inherent power requirements for the CPU boards.

Operation in harsh and hazardous environments

Process plants are found in practically any environment and climate in the world, and the deployment condition for wireless instruments may range from cold winter with snow and ice in arctic regions, to extreme heat and sand in desert regions. The electronic and mechanical components must be designed and encapsulated in order to withstand any external influences, and the wireless communication link must also be able to handle these conditions. Furthermore, most process plants are classified as hazardous areas, where stringent requirements apply to any installed equipment. Regulations and classifications for equipment operating in hazardous areas vary from country to country. In the European Union it is governed by directive 94/9/EC [32] and for the US and Canada it follows the North American Hazardous Locations Installation Codes. The hazardous locations certification documents and standards from the International Electrotechnical Commission (IEC) are used by most other countries in the world.

Commissioning, engineering, provisioning and integration

Wireless instrumentation for industrial applications should provide identical electric and mechanical interfaces as wired systems. As wireless instrumentation is expected to live side by side to wired systems in the foreseeable future, it is imperative that the integration to existing networks, fieldbuses and back-end systems is made as smooth as possible. The mechanical quality and expected lifetime of a wireless instrument should be equivalent to a wired instrument, including the radio communication part of the device. Mounting brackets and other mechanical details, as well as the quality of these, should also be identical to those of wired instruments. Wireless gateways should be mechanically designed to sustain harsh environments, while providing easy mounting and termination of field cables.

Wireless instruments need to be configured before they can join a wireless network. The process of configuring new devices to join an existing network, commonly referred to as provisioning, should be implemented as straight forward as possible in order to ensure this becomes a simple task in the field.

Work processes

Meeting the technical requirements is just one step towards a successful implementation of wireless instrumentation. It is important not to overlook the human factor when adoption new technology, and it is imperative to study and plan for how new solutions can be incorporated into existing work processes. Although wireless instrumentation will eliminate the need for manual labour in relation to maintenance, inspection and operation (e.g. physical inspections and manual data acquisition), the introduction of new work processes is unavoidable. This includes new procedures and tasks for installation, remote configuration, battery replacements and maintenance of wireless transducers and communication systems. A key requirement in this regard is to hide the complex radio-frequency issues related to security, infrastructure

reliability and wireless transmission issues (e.g. noise and interference) from the field worker. Wireless instrumentation systems are designed to be self-configuring and self-healing to adapt dynamically to frequency disturbances, and they incorporate an easily implementable but fully functional security suite, so that they reduce the complexity of work.

4.3 Current status

To date, most wireless instrumentation deployments in the oil & gas industry have been limited to non-critical monitoring applications. Previous research and experience from theoretical studies, laboratory experiments and pilot installations on offshore installations has shown that wireless instrumentation is fully capable of providing sufficient operational performance for non-critical monitoring applications [34][35]. As a result, several oil & gas producing companies has approved wireless instrumentation for non-critical monitoring purposes, and, within these limitations, wireless instrumentation is ready for adoption at scale in the industry. Wireless instrumentation technology is still not considered mature enough for other application areas, as the currently available solutions are not able to fulfil the more stringent requirements for control and safety applications. However, recent research and development of a SIL 2 compliant wireless gas detection system might lead to the approval of wireless instruments for safety applications in the near future [30]. Wireless instrumentation in safety critical systems will be addressed in more detail in the next chapter.

5 Wireless instrumentation in safety critical systems

Safety instrumentation falls into one of two operation modes: continuous and low demand mode. Continuous, or high demand mode, devices are evaluated according to their Probability of Failure per Hour (PFH), i.e. what is the probability of failure in one hour of operation. The low demand mode devices are evaluated according to their Probability of Failure on Demand (PFD).

In the discussion below, both cases are considered. Arguments can be made for either, depending on the type of equipment and the way it is used. The sensor itself can normally be assumed to be low demand mode if it is not an active part of a control loop and that its safe operation is called upon only occasionally. However, if the wireless communication fails for a prolonged period (exceeding the process safety time) the device will not be able to perform its safety function. A communication failure is therefore a "dangerous detected" failure in that any missing packets will be discovered immediately. In the below calculations we consider the contribution to the PFD/PFH of the communication system as a function of repeated packet failure.

It is worth noting that the PROFIsafe standard explicitly allows for wireless communication, detailing the use of WLAN or Bluetooth as carriers. These standards are therefore considered sufficiently robust and secure to provide functional safety over a wireless link. The argument used to support this claim is that PROFIBUS can be used with bit error rates (not packet error rates) up to 10^{-2} , and that this is easily achievable over wireless. The relevant part of the PROFIsafe specification also notes that the primary challenge of wireless is not achieving the required safety, but in the system availability. WirelessHART and ISA100.11a contain similar security mechanisms as WLAN and Bluetooth and they operate in the same frequency band. In addition they are designed for low power consumption, making them better suited for battery operation.

5.1 Standards

5.1.1 General safety standards

The fundamental standards for safety instrumented systems in the process industry are IEC 61508 [36] and IEC 61511 [37]. The former handles all applications where electronic or programmable electronic devices are used to perform safety functions. It is a generic specification and is independent of the final application. It defines the necessary documentation that needs to be developed and maintained as well as the probabilities of failure (PFD or PFH) that need to be achieved to obtain a certain SIL (safety integrity level) level. Its various parts cover hardware, software, and guidelines on how the development shall be performed. It is aimed at manufacturers of equipment.

The latter standard is aimed specifically at the process industry. It takes a more system oriented approach and considers the inclusion of all sorts of equipment (including "proven-in-use") into an over-all view of the process. It is aimed more at integrators and process operators.

5.1.2 Fieldbus communication

The fieldbus communication aspects of safety instrumented systems (SIS) are detailed in IEC61784-3 [38]. This standard considers the communication from the sensor, through the controller, to the actuator. In particular it lists the possible causes of communication error and the required mechanisms that need to be put in place in order to mitigate them. This is summarised in the below table:

Table 1: Failure mechanisms and remedies

Remedy:	Sequence Number	Time Out with Receipt	Codename for Sender and Receiver	Data Consistency Check
Failure type: Repetition	X			
Deletion	X	X		
Insertion	X	X	X	
Resequencing	X			
Data Corruption				X
Delay		X		
Masquerade (standard message mimics failsafe)		X	X	X
FIFO failure within Router		X		

- **Repetition:** Several copies of a transmitted data packet are received at the receiver. This is detected by the receiver when the sequence number is out of order.
- **Deletion:** A data packet is lost. This is also detected by a missing sequence number. If no new packet is transmitted the receiver will eventually time out.
- **Insertion:** Packets other than the intended safety data are present in the data stream. Insertion is handled by erroneous sequence number and by wrong addressing (codename) of the receiver.
- **Resequencing:** The order of the transmitted packets is reshuffled before reaching the receiver. This is handled by the sequence number.
- **Data corruption:** Bit errors in the data stream. This is detected by a cyclic redundancy check (CRC).
- **Delay:** A data packet arrives at the receiver later than expected. This is detected by a time out function. The timer is set to expire well within the required safety times of the process.
- **FIFO failure:** An error within an end or routing device FIFO (first-in, first out) halts the transmission or reception of packets, e.g. by pointer wrapping error. As no packets will no longer flow between the entities, the receiver will eventually time out.

A total of four well implemented remedies are therefore sufficient to ensure safe communication.

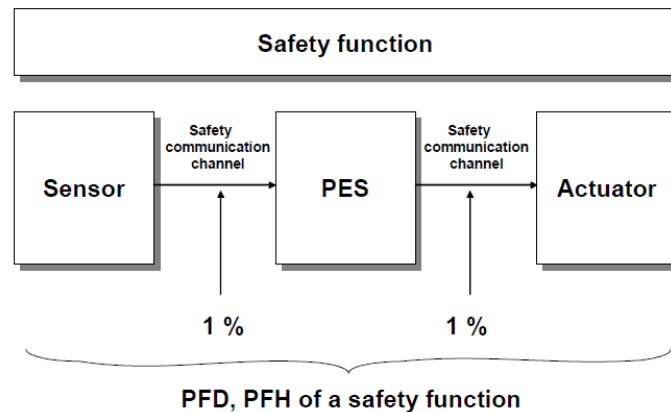

Figure 9: Communication contribution to safety unavailability

The standard also specifies that the communication channels should contribute to no more than 1 % of the acceptable PFD/PFH each. This is shown in Figure 9. Any communication system possessing the above characteristics can, in theory at least, be used for a SIS.

5.1.3 PROFIsafe

IEC61784-3-3 [39] defines PROFIsafe as one of several safety protocols that can be used to achieve functional safety. PROFIsafe has implemented the four safety measures described in the above section. An implementation using PROFIsafe therefore facilitates the SIL certification of a product or system.

The implementation of the four remedies is specific to PROFIsafe.

- **Sequence number:** The sequence number is an eight bit unsigned integer that increases monotonically and wraps at 255. It is not sent over the air, but used as a basis for calculating the CRC. This maintains the functionality, reduces overhead, and makes masquerading more difficult.
- **Timeout:** Every entity in a transmitter-receiver relationship keeps a local version of the timer. It is cleared whenever a safe packet is transmitted and is incremented with a 1ms time resolution. It is represented in a 16 bit unsigned number, implying that the maximum timeout limit the protocol supports is approximately 65 seconds.
- **Codename:** The codename is chosen by the user as a 16 bit identifier.
- **CRC:** The CRC is designed to provide sufficient protection against bit errors. There are two versions: 24 bit and 32 bit. The shorter is used with short data packets (not longer than 12 bytes). Longer packets need the increased protection given by the long CRC.

It is worth keeping in mind that a wireless communication system will have additional checks such as CRC and codename. The remedies put in place by the safety layer thus come in addition to those already implemented in the radio stack.

5.2 Important definitions

Below are a set of definitions from different standards needed to calculate the availability of safety systems using wireless communication.

5.2.1 Process Safety Time (PST)

The process safety time (PST) is defined in [36] as the:

Period of time between a failure, that has the potential to give rise to a hazardous event occurring at the EUC (Equipment Under Control) or EUC control system, and the time by which action has to be completed in the EUC to prevent the hazardous event from occurring.

The PST represents the absolute maximum time delay for suitable safety action. The PST is highly application dependent, and it will naturally affect the acceptable latency in the communication chain. It will often be established based on what is possible with the available equipment, and will include the detection time (DT), the Time to Safe State (TSS), and a margin to compensate for additional delays.

Examples of PSTs include:

- Gas sensors: 60 seconds (IEC 60079-29-1)
- Boiler control: 5-10 seconds (typically, API Recommended Practice 538)
- Pressure valves: 5 seconds or lower (typically, application dependent)

5.2.2 Safety function response time (SFRT)

An additional parameter of interest is the safety function response time (SFRT). It is defined in [38] as:

Worst case elapsed time following an actuation of a safety sensor connected to a fieldbus, before the corresponding safe state of its safety actuator(s) is achieved in the presence of errors or failures in the safety function channel

This definition explicitly allows for problems occurring in the communication medium. In the PROFIsafe standard [39] PST and SFRT are closely linked. Clearly the PST includes also the time taken to detect the failure, a figure that is not implied by the SFRT. Contrary to the PST, the SFRT is often quoted by the manufacturers of equipment as its worst case response time whereas the PST is application dependent.

5.2.3 Availability and probability of failure on demand

Availability can be defined [36] as follows:

Availability 1:

Probability for an automated system that for a given time there are no unsatisfactory system conditions such as loss of production.

In IEC 61508 availability is not explicitly defined, but referred to as being the probability of an item functioning at a given instant (e.g. IEC 61508-4, section 3.4.6). With reference to the new ISO-TR 12489 the term is defined as:

Availability 2:

Probability for an item to be in a state to perform as required at a given instant

The TR points out that for non-repairable systems reliability and availability becomes identical. It should be noted that in PDS the (safety) availability is the major concern, i.e. what is the probability that the component or the system functions upon a demand.

The probability of failure on demand (PFD) for low demand systems is linked to the availability. In [36] it is defined as:

Safety unavailability of an E/EE/PE safety-related system to perform the specified safety function when a demand occurs from the EUC or EUC control system

5.3 Availability calculation

Recall from the discussion in section 5.2.3 that there are several definitions of availability. We will apply the second of the two cited, where availability is related to safety and is defined as the probability of an item (wireless instrument in our case) to perform its intended function upon a demand.

As also discussed above, most failures in the communication can be assumed detected by the safety protocol (Dangerous Detected (DD) failures) and will not contribute significantly to the safety unavailability given that appropriate measures are taken upon an alarm.

A wireless instrument is no longer able to perform its required function when the data no longer gets across the air interface as expected. All wireless protocols contain mechanisms for retransmissions, so single errors do not constitute loss of availability assuming the retransmission is fast enough. We shall assume that a wireless instrument is considered unavailable if the time elapsed between two successive up-link (UL) transmissions exceeds the PST. The availability for a given instrument thus depends on the application in addition to the packet error rate (PER), the frequency of UL transmit opportunities and the fading statistics of the channels.

With a suitable design of the network the PER will be almost guaranteed less than 1 % in the absence of fading and interference. This is achieved by ensuring an appropriate received signal strength, which is specified by the radio vendors as the *radio receiver sensitivity*. The radio sensitivity is a term specified in [4] for standardised IEEE 802.15.4 packets. In the example calculation we shall assume that the probability of packet failure of a wireless system is

$$P_p = 10^{-2}$$

In chapter 6 the independence of successive packets was discussed. Static fading may affect some channels, but not all in a well-designed network. Denote by P_{fade} the probability that a given channel is affected by fading. We shall assume that any faded channel will block communication completely. This is conservative as in practice fading will adversely affect the PER for a given channel without necessarily increasing to 1. But with this conservative approach and assuming that the channels are independent, the probability of a successful transmission can be expressed as:

$$P_{success} = (1 - P_p)(1 - P_{fade})$$

Equivalently, the probability of no successful transmissions during the PST can be expressed as:

$$P_{fail,N} = \left(P_{fade} + P_p(1 - P_{fade}) \right)^N$$

where N is the number of UL transmit opportunities during PST. The graph below evaluates the availability as a function of N for different values of fading probability. We see clearly that the availability approaches

1.0 asymptotically with increasing N . Obtaining the required availability is thus a question of assuring sufficient UL transmit opportunities within the PST.

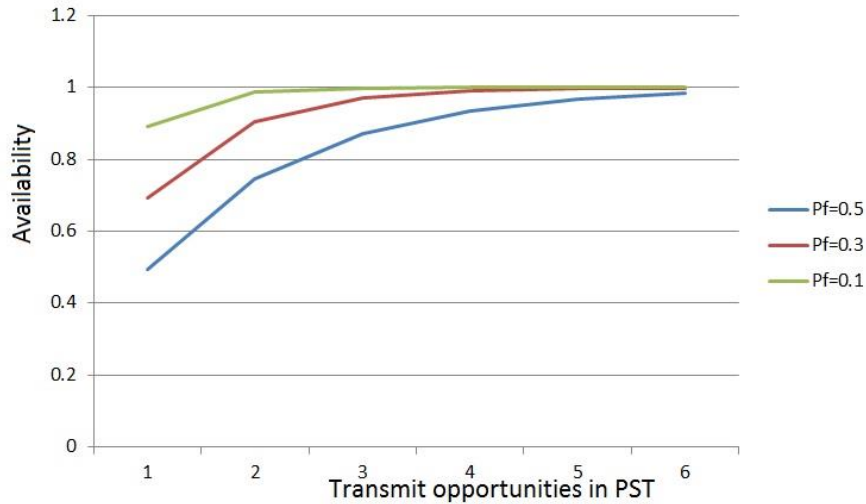

Figure 10: Availability calculation

The above availability calculation does not consider possible loss of communication due to the gateway. Gateway failure rates will vary between vendors and the detrimental effect of gateway failure can be mitigated by using a redundant gateway architecture. A detailed discussion of the implications of this solution is beyond the scope of this document.

6 Comparison wired and wireless detector systems

6.1 Difference between wired and wireless detector systems

A communication system, be it wired or wireless, may introduce errors and unpredictable delays. If the safe communication layer is designed according to the above standards, no malfunction of the communication system will result in a *dangerous undetected* (DU) error. The mechanisms incorporated to avoid DUs are listed above in section 5.1.2 and detailed in [38], and the discussion below assumes that such a system is implemented in the devices. As described above, this can be done using PROFIsafe [39] or some other safe communication protocol such as Foundation Fieldbus, Interbus, CIP, or other. But even if the communication system does not alter the diagnostic coverage, errors may affect the system availability and hence the PFD/PFH.

The main difference between wired and wireless communication systems is the way uncertainty is introduced in the system. Wired systems may suffer packet loss due to severe electromagnetic interference or other errors on the transmission medium. The errors can be temporary or permanent, giving either a random delay or a constant loss of availability. Wireless systems have additional sources of error, the main ones being listed below.

1. Packets can be lost due to a weak RF signal. This can be mitigated by adding more transmitters, more signal power, or using directional antennas. This source of error can therefore normally be controlled by network design.
2. Packets may be lost due to interference, in particular from WLANs operating in the same 2.4GHz band. ISA100.11a [11] and WirelessHART [6] can both handle a certain amount of interference without significant loss of performance [35]. But when the interference becomes excessive, the performance will suffer. The successful operation of a wireless safety system therefore requires control of the use of any co-located WLAN or other interference in the 2.4 GHz range.
3. The device may find itself in a local static fade, i.e. a location where several reflections of the RF signal combine destructively. This fading is frequency selective so that a frequency hopping system (such as both ISA100 and WirelessHART) will still be able to operate. Successive transmission attempts will be statistically independent as long as the channel separation is larger than the coherence bandwidth (CB), where CB can be defined as the bandwidth over which the channel response can be considered flat.
4. Physical obstructions may temporarily block the line of sight between two wireless units. This may reduce the quality of communication and force rerouting of the data traffic. Typically, this results in increased packet latency.

Thus, the use of wireless communication in SISs requires that system operators have sufficient control over resident WLANs and other emitting sources. In addition, care must be taken to adhere to the relevant installation guidelines with respect to signal strength and quality, and also in keeping the process area free from harmful obstructions.

A fault caused by malfunctioning wireless communication can be classified using the PDS handbook [40] as either installation failure (in case installation procedure has not been respected) or operational failure (in case of fading or interference). In both cases there is a potential element of common cause in that neighbouring devices will tend to experience similar transmission conditions.

6.2 Reliability Assessment

6.2.1 Example case

In this Section we will provide an example calculation of the difference between safety unavailability of wired and wireless detector systems (see Figure 11)

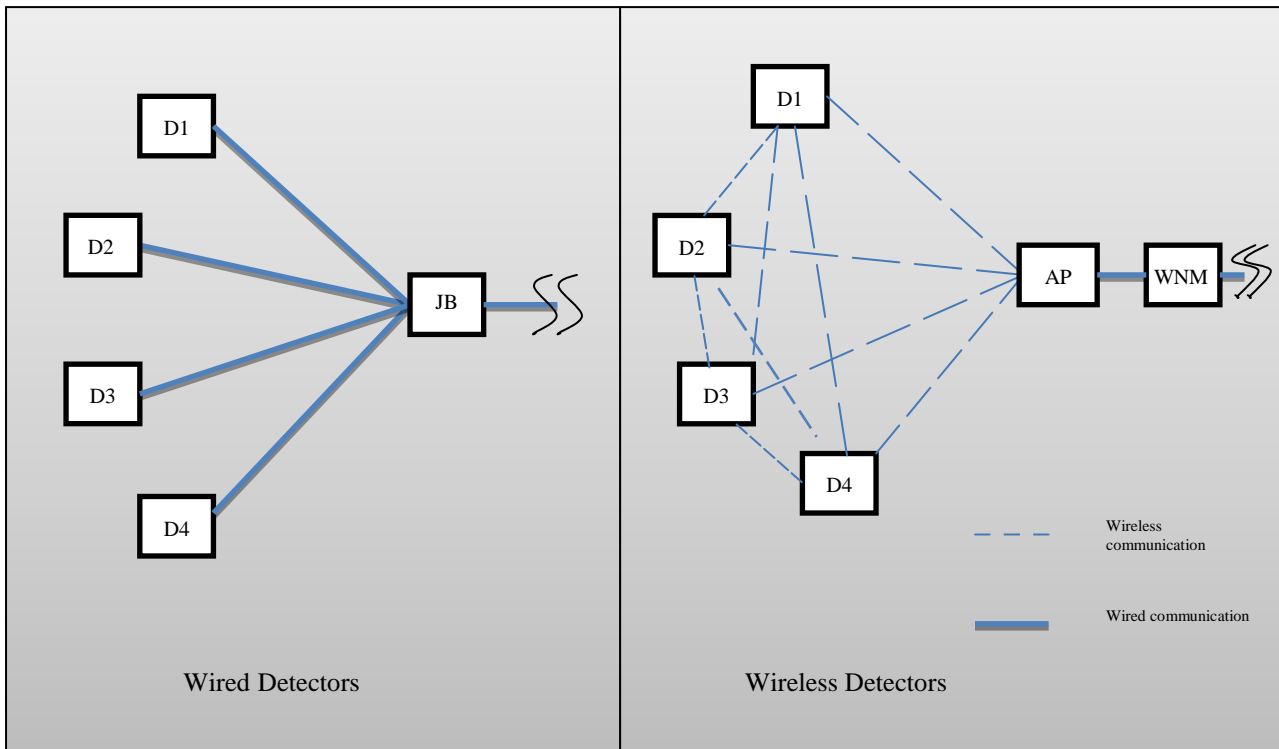

Figure 11: Wired and wireless communication Graph

It is assumed that both gas detection systems are voted 1oo4. The wired detectors transmit data to a junction box (JB). In the wireless network the transmission has redundancy, and each detector can communicate directly with the access point (AP), or use the communication element of the other detectors to communicate with the AP. The Wireless Network Management (WNM) module has a system manager/security manager/gateway function and is located in series with the AP. WNM failure may cause network failure and loss of communication, but the failure can be detected within the diagnostic test interval.

The power module is not included in Figure 1. Although battery failure may result in failure of detector to provide proper signal upon demand (dangerous failure), it should be detected by diagnostic test and thus become a Dangerous Detected (DD) failure. Generally, the battery suffers from degradation (gradual failure) rather than sudden failure. Battery failures may occur if operator fails to monitor battery status and do not replace battery according to established procedures. There may be a minor increase in Downtime Unavailability (DTU) of the system because of extra maintenance time for replacing battery, compared to wired detectors.

6.2.2 Example Reliability Block Diagrams

The Reliability Block Diagram (RBD) of wired and wireless systems are shown in Figure 12 and Figure 13, respectively. The RBD shows how component reliability contributes to the success or failure of a complex system and is drawn as a series of blocks connected in parallel or series. Each block represents a component of the system with a failure rate. Parallel paths are redundant, meaning that all of the parallel paths must fail for the system to fail.

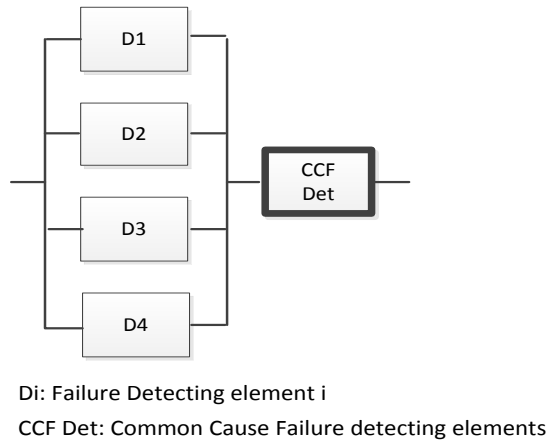

Figure 12: Reliability block diagrams for wired detector system

In the RBD for wireless detector, each wireless detector is split into two elements; the detector element D_i and the detector communication element C_i . It is assumed that the failure rate of the detector element is independent of the detector communication element. As each detector (D_i) in the wireless network has a communication element (C_i) which can communicate directly with the access point (AP), or can communicate indirectly with the AP via another communication element (represented with the element C_{i-j}), the RBD for wireless detector system becomes more complex than the wired detector system.

In the RBD, the communication path between detectors are not taken into consideration and it is assumed that each detector communicates with other detectors directly (i.e. without any intermediate block). This assumption reduces the complexity of the calculations and the effects are negligible as long as the system has redundant communication paths.

Common Cause Failures (CCF) are important for both systems. CCF of detecting element (CCFDet) and communication elements (CCFCom) may be caused by hardware related failure, software faults, installation failure, excessive stress, and operational failures (e.g same operating environment, same vulnerability with regard to security related risk, same communication protocol, etc.). One important factor influencing the reliability of a wireless network is programming of the network protocol which may cause various failure modes. For instance, a programming error may cause the diagnostic testing to enter into a loop.

There are reported failures in traditional hardwired detectors that are caused by water intrusion in the Junction boxes (JB) and freezing inside the JB. In wireless detectors the elimination of wires causes exclusion of the “Junction box”, and consequently no failure of this type.

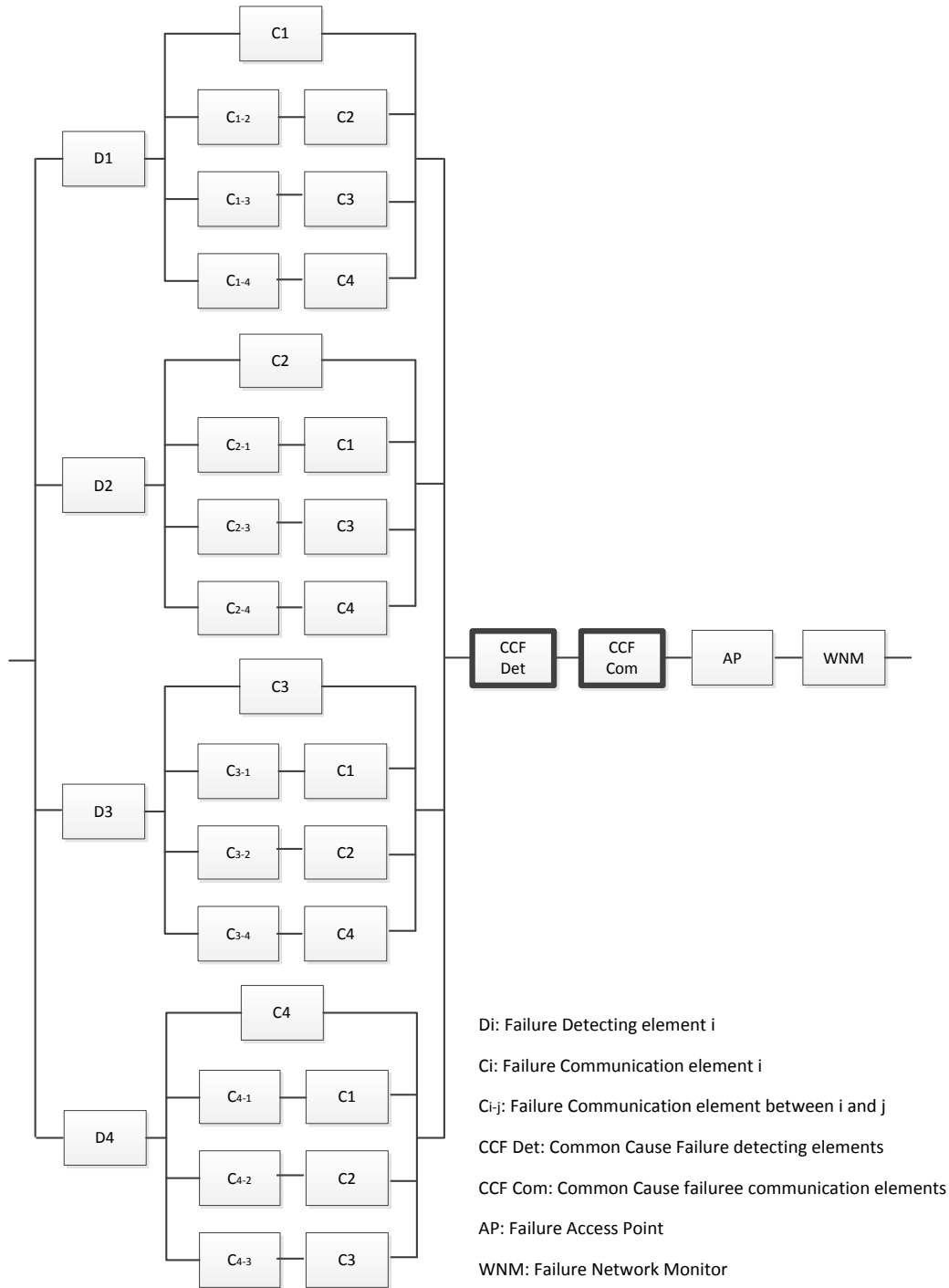

Figure 13: Reliability block diagram for wireless detector system

6.2.3 Safety Unavailability Calculation

According to PDS handbook, the calculation of Critical Safety Unavailability (CSU - the probability that the system fails to automatically carry out successful safety action on the occurrence of a hazardous event) is the sum of PFD, DTU, and P_{TIF} (probability of test independent failure).

In both a wired and wireless system, the occurrence of one common cause detector failure (CCF_{Det}) will cause failure upon demand. In a wireless configuration, also the occurrence of one failure of either AP, WNM, or a common cause communication failure (CCF_{Com}) will cause failure upon demand.

Wired detector system

We can directly apply the PDS model of a 1oo4 voting to calculate PFD, DTU and P_{TIF} . But first we specify the required input data.

Data on wired IR detector failures are available in the PDS Data handbook. It is noted that the given beta factor for CCF is comparable to the β -values obtained when using the CCF-checklist in IEC61508-6 [33]. The junction box has for simplicity been assumed to be part of the common cause failure rate of the detector since the junction box does not have any function besides joining detector wires into one common wire.

Table 2 shows the input parameters applied in the PFD and DTU calculation.

Table 2 Input Parameters

Detector: λ_{DU} (per hour)	Detector: λ_{DD} (per hour)	β	C_{1004}	C_{1003}	H_4	τ (hours)	MTTR (hours)	P_{TIF} (1oo1)
0.6E-6	3.4E-6	0.06	0.3	0.5	1.8	4320	3	0.001

The PDS Handbook now provides the following results for a 1oo4 system of wired detectors. First

$$PFD_{wired} \approx C_{1004} \cdot \beta \cdot \lambda_{DU} \cdot \tau / 2 + \frac{1}{5} (\lambda_{DU} \cdot \tau)^4$$

Here, of course the first term dominates; this equals $0.3 \cdot 0.06 \cdot 0.6E-6 \cdot 4320/2 \approx 2.33 \times 10^{-5}$, and actually in total

$$PFD_{wired} \approx 2.3 \cdot 10^{-5}$$

Next

$$DTU_{wired} \approx C_{1004} \cdot \beta \cdot \lambda_{DD} \cdot MTTR + (N(1 - H_N \beta) \lambda_{DD} \cdot MTTR) \cdot (C_{1003} \cdot \beta \cdot \lambda_{DU} \cdot \tau / 2)$$

Again the first terms dominates, giving $DTU_{wired} \approx 0.3 \cdot 0.06 \cdot 3.4E-6 \cdot 3 \approx 1.84 E-7$, and in total

$$DTU_{wired} \approx 2 \cdot 10^{-7}$$

Finally

$$P_{TIF} = C_{1004} \cdot \beta \cdot 10^{-3}$$

Giving (for 1004, wired)

$$P_{TIF} = 1.8 \cdot 10^{-5}$$

The estimated CSU for wired detectors voted 1004 thus equals:

$$2.3310^{-5} + 2 \cdot 10^{-7} + 1.8 \cdot 10^{-5} \approx 4.1 \times 10^{-5}$$

It should be noted that in this example, the contribution from DTU is insignificant compared to the contributions from PFD and P_{TIF} .

Wireless detector system

For evaluation of PFD for wireless detectors, we restrict to calculating the contributions of the CCFs; which quite obviously provides the dominating term. In addition to the input data given in Table 2, we need the DU and DD failure rates for the communication element (C).

The DU failure rate of the communication element is based on the following assumptions and expert judgments:

- There are four opportunities to send a data packet within 1 minute.
- If four data packets in sequence are lost, this gives a dangerous failure of the wireless system, (response time should be less than 1 minute).
- The data packets are considered independent; *i.e.* loss of one data packet has no impact on the failure of the others.
- It is estimated that there is a constant probability of 0.01 for the loss of a specific data packet.
- Diagnostic test coverage for the communication element (C), (detection of failure in network) is assumed to be 85%, *i.e.* similar to detectors' test coverage. In fact, the diagnostic test coverage for C is probably higher than this number, but using 85% will result in a more "conservative" PFD for wireless systems.

So based on experience from other wireless network and input from experts, the probability of a data packet loss is estimated to equal 0.01. This probability is an average figure and is highly dependent of the number of opportunities to send data. The failure rate for the communication element (C) can now be estimated. A dangerous failure of the system is assumed to occur if four data packets in sequence are lost, and the probability four packets in sequence being lost now equals 10^{-8} . As we have 240 packets sent in one hour, the (upper limit of the) dangerous failure rate will then be $240 \cdot 10^{-8}$ per hour; (*i.e.* the rate of losing four data packets in series during one hour). So for C we get $\lambda_D = 2.4 \cdot 10^{-6}$ per hour. Since the diagnostic test coverage is assumed to be 85%, we get for a C element:

$$\lambda_{DU} = 0,36 \cdot 10^{-6} \text{ per hour}$$

$$\lambda_{DD} = 2,04 \cdot 10^{-6} \text{ per hour}$$

Regarding the betas, the β_1 for the detector element (corresponding to CCF_{Det}) is assumed to be identical for wired and wireless sensors. Estimating β_2 for the communication element (corresponding to CCF_{Com}) using the IEC61508 checklist [33] is challenging. In this CCF-checklist, a major portion of questions and scoring are relevant for wired gas detection system, but apparently irrelevant for wireless ("common wiring", etc.). Hence, it is decided to choose β_2 for C equal to the β_1 for detectors, (equal to the β given in **Error! Reference source not found.**).

In addition, for the purpose of PFD calculation the following are assumed:

- The failure rate of AP is equal to a communication element C.
- Wireless network manager's failure is small and negligible.

Now calculating PFD for the wireless system, we can (as seen for the wired system) restrict to consider the CCF contribution. For the wireless system, the contribution of DU failures of communication and detector elements must be included, (whereas DU failure of the detecting elements only is relevant for the wired system). For the wireless system we get that the CCF contribution to PFD equals

$$0.3 \cdot 0.06 \cdot (0.6+0.36) \cdot 10^{-6} \cdot 4320/2 \approx 3.7 \times 10^{-5}.$$

The contribution to PFD from AP equals

$$0,36 \cdot 10^{-6} \cdot 4320/2 \approx 7,8 \cdot 10^{-4}.$$

Thus, in total

$$PFD_{Wireless} \approx 3.7 \cdot 10^{-5} + 7,8 \cdot 10^{-4} \approx 8,2 \cdot 10^{-4}$$

It is seen that the result is dominated by the AP contribution.

Further assumptions:

- P_{TIF} is equal for wireless and wired.
- As for wired, the DTU term is negligible also for the wireless system.

We can this summarize the comparison between the wired and wireless system as given in the following table.

Table 3 Comparing safety calculations for wired and wireless systems (voted 1004)

System (1004)	PFD	P_{TIF}	CSU
Wired	$2.3 \cdot 10^{-5}$	$1.8 \cdot 10^{-5}$	$4,1 \cdot 10^{-5}$
Wireless	$8,2 \cdot 10^{-4}$	$1.8 \cdot 10^{-5}$	$8,4 \cdot 10^{-4}$

So, the result of these example calculations is that using wireless detectors increases the PFD with a factor close to 40, and the CSU with a factor 20.

7 Case Study: GasSecure

The gas detector is considered a low demand mode instrument. Hence, the considerations from chapter 5 apply. The aim is to design an instrument with SIL2 rating.

7.1 Timing issues

In NORSOK S-001 [41] it is stated that the time from gas exposure until alarm activation should be less than 7 seconds. This time is calculated as the summation of detection time, i.e. 5 seconds, and 2 seconds of transmitting the data to controller and activation of alarm. In practice, the GS01 uses less than 2 seconds on detection, but may use more time on the communication depending on the number of retransmission required. However, care has been taken to keep the total time less than 7 seconds and still comply with the SIL2 requirements for probability of failure on demand.

The PST for gas detectors is 60 seconds. Recall that this is the time between a dangerous failure and the rectification to prevent event from occurring. In other words, the control system needs to be aware of any faulty device well within this time limit.

7.2 Communication considerations

The wireless communication in the GasSecure detector GS01 is handled by ISA100 whereas the safety communication is covered by PROFIsafe. PROFIsafe covers all the necessary mechanisms to achieve SIL certification: code name of sender and receiver, CRC verification of data integrity, sequence numbering, and timeout control.

The safe data exchange takes place between a safety controller and the GS01. The wireless gateway and possible intermediate routing nodes in the wireless network are considered part of a *black channel*, i.e. the elements transport the safety packets only, and the quality of this channel is unknown. The black channel approach allows safe exchange of data over unqualified communication channels. A prerequisite is that the contents of the safe data packets are not tampered with by entities in the channel. Retransmissions and FIFOs are acceptable as long as the incurred delay is not excessive.

The gas detector needs both low power consumption (battery operation) and fast response, to detected gas. These seemingly contradictory requirements are achieved by delaying the response *uplink* (UL: GS01 to controller) to a safe *downlink* (DL: controller to GS01) request. Having received the DL request, the GS01 is said to be armed and can respond quickly to the presence of gas. If no gas or other alarm situations are detected the GS01 responds after a significant part of the process safety time. An example of this mode of operation in the absence of gas is shown in the below figure.

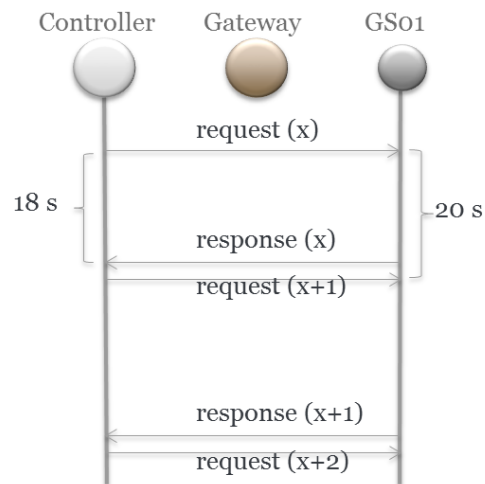

Figure 14: GasSecure SafeWireless

There are two benefits to this structure. First, the need for DL bandwidth is limited and hence battery power is saved. Second, the rapid response time is guaranteed by ensuring that the device is always ready to respond to gas, allowing an activation time down to the 7 seconds specified in [41]. This mode of operation has been termed "SafeWireless" and has been trademarked GasSecure.

8 Future trends

8.1 Safety topology

GasSecure achieves SIL2 certification using a *black channel* approach over ISA100.11a, i.e. that the PROFIsafe entity in the controller communicates directly with the corresponding entity in the GS01 and no assumptions are made on the design and performance of the communication channel. The future release of the WirelessHART standard [6] will reportedly also support functional safety, but may use a different model. Here, the safe entity in the controller will interact with a data storage and -handling entity in the gateway, known as a proxy. Seen from the controller, the proxy will behave like the end device. The proxy will receive the data from the devices and make it available to the controller. It is responsible for the verification of the integrity and timeliness of the data. The proxy is a software entity in the gateway that keeps a connection open with the end device and offers all the device specific data to the controller.

This deviation from the black channel approach has the clear advantage that there is no need to redesign existing WirelessHART devices to achieve SIL2 certification. All that is needed is to install new gateways with a certified proxy. This is a significant simplification for the manufacturers as well as for the device vendors. It will require a gateway that is developed according to the desired SIL level, because the gateway with the proxy is now an active part in the safety implementation.

However, it will require a strict certification of the implementation of the WirelessHART protocol. It needs to be verified that all the possible error conditions (bit errors, packet loss, repetition, masquerading, etc.) are covered by the protocol and that the implementation of the proxy guarantees that any irregularity is adequately detected and reported. It is not certain that SIL2 certification can be given on this basis, but there is a strong industrial interest in getting it done.

The two approaches are fundamentally different. One supports safety all the way to the end device, whereas the other relies on an intermediate proxy. The pros and cons of both should be clear from the above discussion. Which approach will eventually dominate remains to be seen and is primarily a question of industry acceptance.

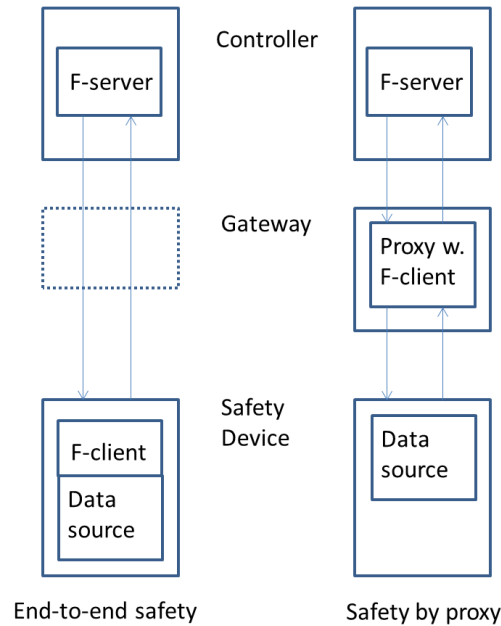

Figure 15: End-to-end versus proxy based safety

8.2 Short cycle time

Some safety application may need very short cycle times and shorter process safety times than the gas detector described above. The time available for faulty communication will be reduced and consequently the UL transmit frequency will increase accordingly. This, in turn, will increase the power consumption.

Furthermore, when the wireless traffic on the network increases sufficiently, the gateway will eventually reach saturation. It will no longer be able to handle all data requests. This problem will be exacerbated during time of critical events, as this will tend to increase the bandwidth utilisation in the system. It is therefore important to scale the system to handle the peak load.

With the higher bandwidth requirement we may therefore run into system limitations, either in terms of throughput through the gateway or device power consumption. When these problems become too pronounced, wireless networks may no longer be a viable alternative.

9 Summary and conclusions

The report considers pros and cons of wireless communication in Safety Instrumented Systems (wireless SIS) in the oil and gas industry. Basic technology and international standards for wireless instrumentation have been investigated along with the technical requirements which must be fulfilled for a successful adoption of this new technology.

- Main benefits of wireless SIS are substantial reductions in installation cost combined with increased flexibility in operation.
- Wireless SIS is best suited in applications characterized by relatively long cycle times and modest response time requirements.
- Application of wireless SIS requires careful design and consideration in terms of bandwidth utilization, power consumption, SIL level, and response time.
- SIL certification of wireless SIS may be obtained by documenting sufficient control over the environment in terms of interference and physical obstacles.
- Several standard safety protocols such as PROFI-safe can be used to achieve functional safety and SIL certification.
- Functional safety of wireless SIS may also be achieved without a standard protocol, but any solution will have to prove that it has implemented the four basic elements: data integrity, timeout control, sequence numbering, and device codename.
- Modern wireless techniques such as ISA100 and WirelessHART are capable of handling safety data. ISA100 can be used 'as is' whereas WirelessHART will need to have some announced safety features included in the official standard. WLAN and Bluetooth have already been qualified for use with PROFI-safe.
- Main performance limitations inherent to wireless SIS are packet loss and low data bandwidth. However, these limitations can be overcome with careful consideration of the system's physical environment.
- A serious challenge for battery powered applications is energy consumption at high update rates. Rapid update cycles require the radio and sensing circuitry to be active for prolonged periods of time and will drain the batteries. Short battery replacement cycles will tend to negatively affect the usability of the safety system.

References

- [1] Chong, C. Y. and Kumar, S. P., "Sensor Networks: Evolution, opportunities and challenges", Proceedings of the IEEE, Vol. 91, No. 8, Aug. 2003.
- [2] IEEE Standard for Information Technology – Telecommunications and information exchange between systems – Local and Metropolitan networks – Specific requirements – Part 15.4: Wireless Medium Access Control (MAC) and Physical Layer (PHY) Specifications for Low Rate Wireless Personal Area Networks (LR-WPANs), IEEE Computer Society, Oct. 2003.
- [3] ZigBee Alliance, ZigBee Specification Version 1.0, Dec. 2004.
- [4] IEEE Standard for Information Technology – Telecommunications and information exchange between systems – Local and Metropolitan networks – Specific requirements – Part 15.4: Wireless Medium Access Control (MAC) and Physical Layer (PHY) Specifications for Low Rate Wireless Personal Area Networks (LR-WPANs), IEEE Computer Society, 2006.
- [5] ZigBee Alliance, ZigBee-2006 Specification, Dec. 2006.
- [6] HART Field Communication Protocol Specification, Revision 7.0, HART Communication Foundation, Sept. 2007.
- [7] Industrial Communication Networks – Wireless Communication Network and Communication Profiles – WirelessHART, International Electrotechnical Commission (IEC) 62591, 2010.
- [8] Lennvall, T., Svensson, S. and Hekland, F., "A Comparison of WirelessHART and ZigBee for Industrial Applications", in Proc. IEEE International Workshop on Factory Communication Systems, May 2008, pp. 85-88.
- [9] ZigBee Alliance, ZigBee PRO Specification, Oct. 2007.
- [10] Wireless Systems for Industrial Automation: Process Control and Related Applications, ISA100.11a-2009, 2009.
- [11] Wireless Systems for Industrial Automation: Process Control and Related Applications, ISA100.11a-2011, 2011.
- [12] Industrial Communication Networks – Fieldbus Specifications – WIA-PA Communication Network and Communication Profile, International Electrotechnical Commission (IEC) 62601, 2009.
- [13] IEEE Standard for Local and metropolitan area networks – Part 15.4: Low-Rate Wireless Personal Area Networks (LR-WPANs) – Amendment 1: MAC sublayer, IEEE Computer Society, April 2012.
- [14] Petersen, S. and Carlsen, S., "Wireless Instrumentation in the Oil & Gas Industry - From Monitoring to Control and Safety Applications", SPE Intelligent Energy International 2012, Utrecht, The Netherlands, March 27-29, 2012, pp. 1-14.
- [15] Radmand, P., Talevski, A., Petersen, S. and Carlsen, S., "Taxonomy of Wireless Sensor Network Cyber Security Attacks in the Oil and Gas Industries", Proceedings of the 24th International Conference on Advanced Information Networking and Applications, Perth, Western Australia, April 20-23, 2010, pp. 949-957.
- [16] Information Technology – Open Systems Interconnection – Basic Reference Model: The Basic Model, ITU-T X.200 (07/94), 1994.
- [17] S. Petersen, P. Doyle, S. Vatland et al., "Requirements, Drivers and Analysis of Wireless Sensor Network Solutions for the Oil & Gas Industry", Proc. of the IEEE Conference on Emerging Technologies and Factory Automation, pp. 219-226, 2007.
- [18] ZigBee Alliance, ZigBee IP Specification, Feb. 2013.
- [19] Internet Engineering Task Force (IETF) – Request For Comments (RFC) 4911 – IPv6 over Low-Power Wireless Personal Area Networks (6LoWPANs): Overview, Assumptions, Problem Statement, and Goals, 2007
- [20] Internet Engineering Task Force (IETF) – Request For Comments (RFC) 4944 – Transmission of IPv6 Packets over IEEE 802.15.4 Networks, 2007
- [21] L. Angrisani, M. Bertocco, D. Fortin, and A. Sona, "Experimental study of coexistence issues between IEEE 802.11b and IEEE Std. 802.15.4 wireless networks," IEEE Trans. Instrum. Meas., vol. 53, no. 8, pp. 1514–1523, Aug 2008.

- [22] D. Chen and P. K. Varshney, "QoS Support in Wireless Sensor Networks: A Survey", *Communication* 13244, 2004, pp. 227–233.
- [23] M. A. Yigitel, O. D. Incel and C. Ersoy, "QoS-aware MAC protocols for wireless sensor networks: A survey", *Computer Networks* 55, 2011, pp. 1982-2004.
- [24] R. Braden, D. Clark and S. Shenker, "Integrated services in the internet architecture – An overview", *IETF RFC 1663*, June 1994.
- [25] S. Blake et.al, "An architecture for differentiated services", *IETF RFC 2475*, Dec. 1998.
- [26] S. Bhatnagar, B. Deb and B. Nath, "Service differentiation in Sensor Networks", *Proc. of Int. Symposium on Wireless Personal Multimedia Communications*, Aalborg, Denmark, Sept. 9-12, 2001.
- [27] International Electrotechnical Commission (IEC), *IEC 61508 – Functional safety of electrical/electronic/programmable electronic safety-related systems - ALL PARTS*, 2010.
- [28] International Electrotechnical Commission (IEC), *IEC 61784-3-3 – Industrial communication networks – Profiles – Part 3-3: Functional safety fieldbuses – Additional specifications for CPF 3*, 2007.
- [29] International Electrotechnical Commission (IEC), *IEC 61158 – Industrial communication networks – Fieldbus specifications*, 2007.
- [30] Ikram, W. et al., "Towards the Development of a SIL Compliant Wireless Hydrocarbon Leakage Detection System", *Proceedings of the International Conference on Emerging Technologies and Factory Automation*, Cagliari, Italy, Sept. 10-13, 2013, pp. 1-8.
- [31] NAMUR NE 124:2010, "Wireless Automation Requirements", 2010.
- [32] European Parliament and the Council, *Directive 94/9/EC*, 1994.
- [33] International Electrotechnical Commission (IEC), *IEC 61508 – Functional safety of electrical/electronic/programmable electronic safety-related systems - ALL PARTS*, 2010.
- [34] Carlsen, S., Skavhaug, A., Petersen, S. and Doyle, P., "Wireless sensor network installed on a North Sea platform", *World Oil*, Vol. 230, No. 9, Sept. 2009, pp. 93-97.
- [35] Petersen, S. and Carlsen, S., "Performance Evaluation of WirelessHART for Factory Automation", *Proceedings of the 14th IEEE International Conference on Emerging Technologies and Factory Automation*, Palma, Mallorca, Spain, Sept. 22-26, 2009, pp. 1-9.
- [36] *Functional safety of electrical/electronic/programmable electronic safety-related systems, Edition 2.0.*, International Electrotechnical Commission (IEC) 61508, 2010.
- [37] *Functional safety – Safety instrumented systems for the process industry sector*, International Electrotechnical Commission (IEC) 61511, 2004.
- [38] *Industrial Communication Networks – Profiles – Part 3: Functional safety Fieldbuses – General rules and profile definitions, Edition 2.0*, International Electrotechnical Commission (IEC) 61784-3, 2010.
- [39] *Industrial Communication Networks – Profiles – Part 3-3: Functional safety Fieldbuses – Additional Specifications for CPF 3, Edition 2.0*, International Electrotechnical Commission (IEC) 61784-3-3, 2010.
- [40] *PDS Method Handbook*, 2013
- [41] *NORSOK S-001*



Technology for a better society

www.sintef.no