

www.sintef.no



Rapporten er utarbeidet i samarbeid med:



**SINTEF****SINTEF Energiforskning AS**

Postadresse: 7465 Trondheim
 Resepsjon: Sem Sælands vei 11
 Telefon: 73 59 72 00
 Telefaks: 73 59 72 50

www.energy.sintef.no

Foretaksregisteret:
 NO 939 350 675 MVA

TEKNISK RAPPORT

SAK/OPPGAVE (tittel)

Vindkraft FoU Seminar – Fokus på offshore!
22. – 23. januar 2009

SAKSBEARBEIDER(E)

John Olav Tande

OPPDRAGSGIVER(E)

TR NR. TR A6785	DATO 2009-02-12	OPPDRAGSGIVER(E)S REF.	PROSJEKTNR. 12X278
EL. ARKIVKODE 090129RHA105644	RAPPORTTYPE	PROSJEKTANSVARLIG (NAVN, SIGN.) John Olav Tande	GRADERING ÅPEN
ISBN NR. 978-82-594-3395-4		FORSKNINGSSJEF (NAVN, SIGN.) Petter Støa	OPPLAG SIDER 10 146
AVDELING SINTEF Energiforskning AS	BESØKSADRESSE Sem Sælands vei 11		LOKAL TELEFAKS 73 59 72 50

RESULTAT (sammendrag)

Denne rapporten gjengir presentasjoner fra Vindkraft FoU seminar 22.-23. januar 2009 i Trondheim. Seminaret er en oppfølging på tilsvarende arrangert i 2004, 2005, 2006, 2007 og 2008, og er etablert som en viktig møteplass for alle norske vindkraftaktører. Følgende tema er presentert:

- Offshore vind: en gylden mulighet
- Nye konsepter og teknologi
- Nettintegrasjon
- Vind, drift og vedlikehold
- Eksperimenter og demonstrasjon
- Norsk innovativ offshore vindkraftteknologi

Seminaret er arrangert av SINTEF, IFE og NTNU i fellesskap ved John Olav Tande (SINTEF Energiforskning), Per Finden (IFE/NTNU), Geir Moe (NTNU), Terje Gjengedal (Statkraft/NTNU), Olav Fosso (NTNU), Erik Berge (Kjeller Vindteknikk), Tore Undeland (NTNU), Bård W. Tveiten (SINTEF) og Atle Minsaas (MARINTEK)

STIKKORD

EGENVALGTE		

INNHALDSFORTEGNELSE

	<u>Side</u>
1 PROGRAM	4
2 DELTAKERLISTE	6
 PRESENTASJONER	
Offshore vind: en gylden mulighet	
Strategi for utvikling av offshore vind, Terje Gjengedal, Statkraft/NTNU.....	10
Veikart for utvikling av offshore vind i Nordsjøen: EU-prosjektet WindSpeed, Karina Veum, ECN.....	14
Behov og nytte av koordinert forskning på offshore vindkraft, John Olav Tande, SINTEF Energiforskning.....	16
Utvikling av det norske offshore vindmarkedet gjennom test og demonstrasjon, Kjell Olav Skjølsvik, Enova SF	19
Nye konsepter og teknologi	
Lange blader for offshore turbiner, Jørg Høyland, NTNU.....	21
Individuell pitch av vindturbinblader, Fredrik Sandquist, NTNU.....	26
Svingninger i vindturbinunderstell, Paul Thomassen, NTNU.....	29
SmartBlades for offshore vindturbiner, Andreas Knauer, IFE.....	32
Model tests of turbine in yaw condition, M.S. Adaramola, NTNU.....	35
BEM rotor analyses vs. measurements, Karl Merz, NTNU.....	38
Truss towers for offshore wind turbines, Haiyan Long, NTNU.....	39
Regulering av flytende vindturbiner, Thomas Fuglseth, NTNU.....	41
Korrosjonsbeskyttelse av vindturbiner, Ole Knudsen, SINTEF Materialer og Kjemi.....	48
Optimalisering av flyter og ankersystem, Ivar Fylling, MARINTEK.....	51
Nettintegrasjon	
Kontrollmetoder for variabel hastighet turbiner, Jarle Eek, SINTEF Energiforskning.....	54
Centralized control of wind farms, Bing Liu, NTNU.....	58
Multi-terminal HVDC for offshore wind farms, Temesgen M. Haileselassie, NTNU.....	61
Vindkraft til offshore olje og gass installasjoner, Magnus Korpås, SINTEF Energiforskning.....	64
Offshore vind i Europa – TradeWind, Kjetil Uhlen, SINTEF Energiforskning.....	67
System impacts of large scale wind farms, Tobias Aigner, NTNU.....	73
Planer for offshore transmisjonsnett, Kjartan Hauglum, Statnett.....	75
Optimalt design av offshore transmisjonsnett, Thomas Trötscher, Statnett/SINTEF/BKK.....	77
HVAC tilkobling av offshore vindparker, Georg Balog, Nexans.....	79
Lillgrund vindpark, Jan Norling, Vattenfall.....	83

Vind, Drift og Vedlikehold

Offshore vindressurskartlegging, Øyvind Byrkjedal, Kjeller Vindteknikk.....	86
Hvordan havbølger påvirker vindprofilen og turbulens i atmosfæren, Alastair D. Jenkins, UiB.....	90
Effects of wakes in offshore wind farms, S. Frandsen, Risø DTU.....	85
Airborne Maintenance & Repair (M&R) Applications for Wind Turbines, Ben-David Hanan, WindSL.....	100
Drift og vedlikehold av offshore vindkraftverk, Jørn Heggset, SINTEF Energiforskning.....	107
Bøyeteknologi for måling av vind, bølger og strøm, Jan-Petter Mathisen, Fugro Oceanor.....	110
Ekspirimententer og demonstrasjon	
Hydraulisk gir for vindkraftverk, Svein Kjetil Haugset, ChapDrive.....	114
Mekanisk drivelinje med eksentergir og vertikal aksel mellom rotor og generator i bunnen av Tårnstruktur, Lars Raunholt, AngleWind.....	116
Ny generatorteknologi for vindkraftverk, Sigurd Øvrebø, SmartMotor.....	119
Testområde Stadt, Edgar Kvernevik, Vestavind.....	121
OWEC Tower sitt forskningsprogram ved testfeltet Alpha Ventus, Sveinung Nesheim,..... OWEC Tower AS	125
WindSea – 3 turbiner – 1 plattform, Marc Lefranc, Windsea.....	129
Norsk innovative offshore vindkraftteknologi	
Norsk satsning på offshore vindkraft, Robin Martin Kåss, OED.....	131
Offshore vind – en ny industri og et nytt marked for Aker Solutions, Åge Tårnes, Aker Solutions.....	134
ScanWind status og veien videre, Kristian Holm, ScanWind.....	138
Offshore Vind 2010 – 2020, Eystein Borgen, SWAY.....	140
Status Hywind og vedlikeholds strategier for offshore vind, Elly Karlsen, StatoilHydro.....	143

Vindkraft FoU Seminar – fokus på offshore!	
22-23 januar 2009, Royal Garden Hotell, Kjøpmannsgata 73, Trondheim	
Torsdag 22 Januar	
09.00	Registrering & kaffe/mineralvann
Offshore vind: en gylden mulighet Ordstyrer: Prof. Per Finden, IFE/NTNU; Marit Reiso, PhD stud. NTNU	
09.30	Åpning og velkommen ved ordstyrer
09.40	<i>Strategi for utvikling av offshore vindkraft</i> Terje Gjengedal, Vice President Statkraft / Prof NTNU
10.10	<i>Status og potensial for utvikling av offshore vindkraftteknologi</i> Bo Rohde Jensen, Senior Specialist, Vestas Technology R&D
10.30	<i>Veikart for utvikling av offshore vind i Nordsjøen: EU-prosjektet WindSpeed</i> Karina Veum, Senior policy adviser, ECN
10.50	<i>Behov og nytte av koordinert forskning på offshore vindkraft</i> John Olav Tande, Seniorforsker, SINTEF Energiforskning
11.10	<i>Utvikling av det norske offshore vindmarkedet gjennom test og demonstrasjon</i> Kjell Olav Skjølvsvik, Områdeleder Ny Teknologi, Enova SF
11.30	Oppsummering og diskusjon ved ordstyrer
12.00	Lunsj
Parallelle sesjoner	
	A1) Nye konsepter og teknologi Ordstyrer: Prof. Geir Moe, NTNU E. E. Aasheim, stud. NTNU
	B1) Nettintegrasjon Ordstyrer: Prof. Tore Undeland, NTNU Jon Are Suul, PhD stud. NTNU
13.00	Innledning ved ordstyrer
13.10	<i>Lange blader for offshore turbiner</i> Jørg Høyland, PhD student NTNU
13.30	<i>Individuell pitch av vindturbinblader</i> Fredrik Sandquist, PhD student NTNU
13.45	<i>Svingninger i vindturbinunderstell</i> Paul Thomassen, Post doc NTNU
14.00	<i>SmartBlades for offshore vindturbiner</i> Andreas Knauer, Forsker IFE
14.20	<i>Model tests of turbine in yaw condition</i> M. S. Adaramola, Post doc NTNU
14.40	<i>BEM rotor analyses vs. measurements</i> Karl Merz, PhD student NTNU
15.00	Pause med lett servering
	A2) Nye konsepter og teknologi Ordstyrer: B. W. Tveiten, SINTEF MK E. E. Aasheim, stud. NTNU
	B2) Nettintegrasjon Ordstyrer: Prof. Olav Fosso, NTNU Jon Are Suul, PhD stud. NTNU
15.30	Innledning ved ordstyrer
15.40	<i>Truss towers for offshore wind turbines</i> Haiyan Long, PhD student NTNU
16.00	<i>Regulering av flytende vindturbiner</i> Thomas Fuglseth, PhD student NTNU
16.20	<i>Korrosjonsbeskyttelse av vindturbiner</i> O Knudsen, Seniorforsker SINTEF MK
16.40	<i>Optimalisering av flyter og ankersystem</i> Seniorforsker I. Fylling, MARINTEK
17.00	Pause
18.00	Middag; Toast Master Prof. Tore Undeland, NTNU

Vindkraft FoU Seminar – fokus på offshore!	
22-23 januar 2009, Royal Garden Hotell, Kjøpmannsgata 73, Trondheim	
Fredag 23 Januar	
Parallele sesjoner	
C) Vind, Drift og Vedlikehold Ordstyrer: Erik Berge, KVT / IFE B. Solemslie, stud. NTNU	D) Eksperimenter og demonstrasjon Ordstyrer: Atle Minsaas, MARINTEK Erik Rød, stud. NTNU
09.00	Innledning ved ordstyrer
09.10	<i>Offshore vindressurskartlegging</i> Øyvind Byrkjedal, Kjeller Vindteknikk
09.30	<i>Hvordan havbølger påvirker vindprofilen og turbulens i atmosfæren</i> Alastair D. Jenkins, Forsker UiB
09.50	<i>Effects of wakes in offshore wind farms</i> S. Frandsen, Senior scientist Risø DTU
10.10	<i>Airborne Maintenance & Repair (M&R) Applications for Wind Turbines</i> Ben-David Hanan, WindSL
10.30	<i>Drift og vedlikehold av offshore vindkraftverk;</i> J. Heggset, Seniorforsker SINTEF Energiforskning
10.50	<i>Bøyeteknologi for måling av vind, bølger og strøm;</i> Jan-Petter Mathisen, Fugro Oceanor
11.10	Pause med lett servering
Norsk innovativ offshore vindkraftteknologi Ordstyrer: Seniorrådgiver Jan Onarheim, NTNU; Marianne Meling, stud. NTNU	
11.40	Innledning ved ordstyrer
11.45	<i>Norsk satsning på offshore vindkraft</i> Robin Martin Kåss, Statssekretær, Olje- og energidepartementet
12.05	<i>Offshore vind - en ny industri og et nytt marked for Aker Solutions</i> Åge Tårnes, Aker Solutions
12.25	<i>ScanWind status og veien videre</i> Kristian Holm, ScanWind
12.45	<i>Offshore Vind - 2010-2020</i> Eystein Borgen, Adm. dir. SWAY
13.05	<i>Status Hywind og vedlikeholds strategier for offshore vind,</i> Elly Karlsen, StatoilHydro
13.25	Oppsummering ved ordstyrer
13.30	Lunsj / Slutt

Deltakerliste med email, Vindkraftseminar, 22. – 23. januar 2009

Navn	Firma	Email
Adaramola, M.S.	NTNU	muyiwa.adaramola@ntnu.no
Aigner, Tobias	NTNU	tobias.aigner@elkraft.ntnu.no
Balog, Georg	Nexans	georg.balog@nexans.com
Barstad, Idar	Bjerknessenteret for klimaforskning	idar.barstad@bjerknes.uib.no
Berg, Jon	Sarsia Seed Management AS	jon@sarsia.com
Berge, Erik	Kjeller Vindteknikk	erik.berge@vindteknikk.no
Bergvoll, Øyvind	StatoilHydro ASA	OYBERG@statoilhydro.com
Bjørngum, Astrid	SINTEF Materialer og Kjemi	astrid.bjorgum@sintef.no
Björk, Mikael	ScanWind	mikael.bjork@scanwind.com
Blomquist, Jens Peter	Sway AS	ey@sway.no
Bonding, Pia Bergmann	DONG Energy	piara@dongenergy.dk
Boot, Jan Maarten	Energuide AS	janmaartenb@energuide.no
Borgen, Eystein	Sway	Eystein.Borgen@sway.no
Borup, Kim O.	MacArtney AS	kob@macartney.com
Bratland, Andreas	Norges forskningsråd	hoh@rcn.no
Bratland, Sjur	StatoilHydro	sjub@statoilhydro.com
Breistein, Hallvard	NTNU (student)	hallvard.breistein@gmail.com
Brurok, Torgeir	MARINTEK	torgeir.brurok@marintek.sintef.no
Byrkjedal, Øyvind	Kjeller Vindteknikk	oyvind.byrkjedal@vindteknikk.no
Båtevik, Beate Valaker	Vestavind Kraft AS	beate.baatevik@vestavindkraft.no
Croonenborghs, Eloïse	UCL	ecroonenborghs@gmail.com
Dahl, Bergny	Innovasjon Norge	bedah@innovasjon norge.no
Ditlefsen, Arne Marius	NTNU (student)	arnemad@stud.ntnu.no
Echtermeyer, Andreas	NTNU	Andreas.Echtermeyer@ntnu.no
Eek, Jarle	SINTEF Energiforskning AS	jarle.eek@sintef.no
Fasting, Einar	SINTEF Energiforskning AS	Einar.Fasting@sintef.no
Finden, Per	IFE	Per.Finden@ife.no
Fodstad, Lars Audun	Statkraft Energi AS	laf@statkraft.com
Fosso, Olav B.	NTNU	Olav.fosso@ntnu.no
Frandsen, S.	Risø DTU	
Fredriksen, Anne	Markedskraft ASA	AFR@Markedskraft.com
Fretheim, Harald	ABB AS	harald.fretheim@no.abb.com
Frøyd, Lars	NTNU (student)	froyd@stud.ntnu.no
Fuchs, Ida	NTNU (student)	idafu@elkraft.ntnu.no
Fuglseth, Thomas	NTNU	thomas.fuglseth@elkraft.ntnu.no
Furuset, Åsmund	ChapDrive AS	asmund.furuset@chapdrive.com
Fyling, Ivar	Marintek	ivar.fyilling@marintek.sintef.no
Garpestad, Eimund	ConocoPhillips	eimund.garpestad@conocophillips.com
Gjengedal, Terje	Statkraft / NTNU	Terje.Gjengedal@statkraft.com
Gjerde, Sverre Skalleberg	NTNU (student)	sverresk@stud.ntnu.no
Godvik, Marte	DNV	marte.godvik@dnv.com
Goethe, Stig	Svensk Vindforsk	stig.goethe@telia.com
Grande, Ove	SINTEF Energiforskning	ove.grande@sintef.no

Gravdahl, Arne Reidar	WindSim AS	arne@windsim.com
Gaarder, Rune H.	SINTEF Materialer og Kjemi	Rune.H.Gaarder@sintef.no
Haileselassie, Temesgen M.	NTNU	hailese@elkraft.ntnu.no
Hanan, Ben-David	WindSL	benda@wind-sl.com
Hansen, Dag Arild	Hybrid Technology AS	dag.arild.hansen@hybridtech.no
Hanson, Tor David	StatoilHydro	TDHA@StatoilHydro.com
Hauglum, Kjartan	Statnett SF	Kjartan.hauglum@statnett.no
Haugset, Svein Kjetil	ChapDrive AS	haugset@chapdrive.com
Heggset, Jørn	SINTEF Energiforskning	jorn.heggset@sintef.no
Heilmann, Katrine Laursen	DONG Energy	kathe@dongenergy.dk
Henriksen, Morten	Arendals Fossekompani	morten.henriksen@arendalsfoss.no
Hermansen, Tonje Skoglund	DNV	tonje.skoglund.hermansen@dnv.com
Hienn, Kirsti	Nordnorsk Havkraft AS	kirsti.hienn@nordnorskhavkraft.no
Hjetland, Ann Ingeborg	OED	aih@oed.dep.no
Hofstad, Knut	NVE	kho@nve.no
Holberg, Amund	NTNU (student)	aholberg@gmail.com
Hole, Lars Robert	MET	lrh@met.no
Holm, Kristian	ScanWind Group AS	kristian.holm@scanwind.com
Hopstad, Anne Lene	DNV	anne.lene.hopstad@dnv.com
Høiseth, Mette Kjelstad	SINTEF Energiforskning	Mette.K.Hoiseth@sintef.no
Høyland, Jørg	NTNU	jorg.hoyland@ntnu.no
Haarberg, Per Olav	ChapDrive AS	trpoh@online.no
Hårklau, Thomas	Kitemill AS	thomas.harklau@kitemill.no
Haavik, Henriette R.	Statkraft Development AS	henriette.haavik@statkraft.com
Imafidon, Oliver Osaze	NTNU (student)	imafidon@stud.ntnu.no
Ivarsson, Stefan	ScanWind	stefan.ivarsson@scanwind.com
Jacobsen, Malthe	DONG Energy	malja@dongenergy.dk
Jafar, Muhammad	NTNU	muhammad.jafar@elkraft.ntnu.no
Jenkins, Alastair	Universitetet i Bergen	alastair.jenkins@gfi.uib.no
Jensen, Bo Rohde	Vestas Wind Systems AS	BRJ@VESTAS.COM
Jensen, Dorte Buus	Vestas Offshore	
Kanestrøm, Mette Kristine	Lyse Produksjon AS	mettekristine.kanestrom@lyse.no
Karlsen, Elly	StatoilHydro	elkar@statoilhydro.com
Karlsen, Jon Amund	NTNU (student)	jamk@online.no
Knauer, Andreas	IFE	andreas.knauer@ife.no
Knudsen, O.	SINTEF Materialer og Kjemi	ole.knudsen@sintef.no
Kolstad, Ulf	Statnett SF	ulf.kolstad@statnett.no
Korpås, Magnus	SINTEF Energiforskning AS	magnus.korpas@sintef.no
Kostøl, Øystein	Statkraft Development AS	oystein.kostol@statkraft.com
Kravik, Reiar	Kjeller Vindteknikk	reiar.kravik@vindteknikk.no
Kristensen, Jonas	Vestas Wind Systems AS	jnkr@vestas.com
Kristiansen, Øyvind	Statkraft Development AS	oyvind.kristiansen@statkraft.com
Krokstad, Jørgen Ranum	Statkraft	Jorgen.Ranum.Krokstad@statkraft.no
Kvamsdal, Trond	NTNU	Trond.Kvamsdal@math.ntnu.no
Kvernevik, Edgar	Vestavind kraft AS	edgar.kvernevik@vestavindkraft.no
Kvaal, Bernhard	TrønderEnergi Kraft AS	bkv@tronderenergi.no
Larssen, Marit	Statnett SF	marit.larssen@statnett.no
Laukhammer, Vegard	Bergen Group Engineering	vegard.laukhammer@bergengroup.no
Lefranc, Marc	Force Technology Norway AS	mrl@force.no
Lindeberg, Eivind	NTNU	elindeberg@gmail.com

Lindeberg, Mikael	ScanWind	mikael.lindberg@scanwind.com
Liu, Bing	NTNU	Bing.Liu@elkraft.ntnu.no
Long, Haiyan	NTNU	haiyan.long@ntnu.no
Lorås, Kåre	TrønderEnergi Kraft AS	kl@tronderenergi.no
Lurås, Kari	StatoilHydro	kalur@statoilhydro.com
Madjid Karimirad	NTNU (student)	madjid.karimirad@ntnu.no
Mathisen, Jan-Petter	Fugro Oceanor	j.mathisen@oceanor.com
Mathisen, Kjell Magne	NTNU	kjell.mathisen@ntnu.no
Meling, Marianne	NTNU	marianme@stud.ntnu.no
Merz, Karl	NTNU	karl.merz@ntnu.no
Mikkelsen, Hans Jørgen	Force Technology Norway AS	hjm@force.no
Minsaas, Atle	Marintek	atle.minsaas@marintek.sintef.no
Moe, Geir	NTNU	geir.moe@ntnu.no
Mongstad, Trygve	SFFE	trygve.t.mongstad@ntnu.no
Møllersen, Magnus	NTNU (student)	mollersen@gmail.com
Nesheim, Sveinung	OWEC Tower AS	sveinung@owectower.no
Nielsen, Henrik Pihl	MacArtney AS	hpn@macartney.com
Nitter, Hermod	Troll WindPower	hermod.nitter@trollpower.no
Norling, Jan	Vattenfall Vindkraft AB	jan.norling@vattenfall.com
Nybakke, Karen	NVE	kany@nve.no
Nygaard, TorAnders	UMB	tor.anders.nygaard@umb.no
Nyhammer, Finn	Kjeller Vindteknikk AS	finn.nyhammer@vindteknikk.no
Næss, Arild	Energuide AS	arildn@energuide.no
Næss, Bjarne Idsøe	Unitech Power Systems AS	bjarne@unitech.no
Olguin, Raymundo Torres	NTNU	
Onarheim, Jan	NTNU	jan.onarheim@ntnu.no
Onsøien, Morten I.	SINTEF Materialer og Kjemi	morten.i.insoien@sintef.no
Oosterkamp, Tony	Forskningsstiftelsen Polytec	oosterkamp@polytec.no
Paus, Jørn	StatoilHydro ASA	gorpa@c2i.net
Pedersen, Morten	NTNU (student)	mortendi@stud.ntnu.no
Pettersen, Bernt Øyvin	Rambøll Norge AS	bernt.pettersen@ramboll.no
Pettersen, Ove Jørås	Blaaster Wind Technologies	
Pettersen, Torolf	Blaaster Wind Technologies	
Raunholt, Lars	Angle Wind AS	lars@seabedrig.com
Reiso, Marit	NTNU	Marit.reiso@ntnu.no
Rikheim, Harald	Statkraft Development AS	harald.rikheim@statkraft.com
Rodriguea, Haim	WindSL	haimr@rsl-electronics.com
Ryengen, Kathrine Kværnæs	OceanWind	kathrinekvaernaes@gmail.com
Rød, Erik	NTNU (student)	erikr@stud.ntnu.no
Røkke, Nils	SINTEF	nils.a.rokke@sintef.no
Rönquist, Anders	NTNU	anders.ronnquist@ntnu.no
Røset, Einar	Siemens AS	einar.roset@siemens.com
Sandquist, Fredrik	NTNU	fredrik.sandquist@ntnu.no
Sivertsvoll, Børre Johansen	Troll Power AS	borre.sivertsvoll@trollpower.no
Skare, Eirik	SmartMotor AS	eirik.skare@smartmotor.no
Skjølsvik, Kjell Olav	Enova SF	kjell.olav.skjolsvik@enova.no
Skorpen, Per Ove	Rambøll Norge AS	per.ove.skorpen@ramboll.no
Skotland, Christer Heen	NTNU (student)	skotland@stud.ntnu.no
Skånøy, Thomas	Siemens AS	thomas.skaanoey@siemens.com
Solemslie, Bjørn	NTNU	bjornsol@stud.ntnu.no

Spooren, Rudie	SINTEF Materialer og Kjemi	rudie.spooren@sintef.no
Stenbro, Roy	IFE	roy.stenbro@ife.no
Stensen, Hanne	Statnett SF	hanne.stensen@statnett.no
Sterten, Rolf	TrønderEnergi Kraft AS	rst@tronderenergi.no
Stoltz, Kai	Sway AS	ey@sway.no
Straume, Harald	Bergen Group Rosenberg	Harald.Straume@rosenbergverft.com
Kåss, Robin Martin	OED	
Suul, Jon Are	NTNU	Jon.are.suul@stud.ntnu.no
Svanem, Kathrine P.	StatoilHydro ASA	kapet@statoilhydro.com
Svendgård, Ole	VIVA	ole.svendgard@vivawind.no
Svendsen, Trine	SWECO Norge AS	trine.svendsen@sweco.no
Sætern, Arnt Inge	TrønderEnergi Kraft	ais@tronderenergi.no
Søyland, Petter Faye	Aker Marine Contractors	petter.faye.soeyland@akersolutions.com
Tande, John Olav	SINTEF Energiforskning	john.o.tande@sintef.no
Thomassen, Paul	NTNU	paul.thomassen@ntnu.no
Tollefsen, Bjørn	EDR AS	bjorn.tollefsen@edr.no
Trötscher, Thomas	Statnett SF	
Tveiten, B.W.	SINTEF Materialer og Kjemi	bard.w.tveiten@sintef.no
Tårnes, Åge	Aker Solutions	age.tarnes@akersolutions.com
Uhlen, Kjetil	SINTEF Energiforskning AS	Kjetil.Uhlen@sintef.no
Ulriksen, Torbjørn	Rambøll AS	thorbjorn.ulriksen@ramboll.no
Undeland, Tore	NTNU	tore.undeland@elkraft.ntnu.no
Veum, Karina	ECN	
Vogstad, Klaus-Ole	Agder Energi Produksjon	Klaus-Ole.Vogstad@ae.no
Vormedal, Lars Kr.	Statnett SF	lars.vormedal@statnett.no
Vrana, Til Kristian	NTNU	til.kristian.vrana@elkraft.ntnu.no
Vågø, Per Tore	ScanWind Group AS	per.tore.vago@scanwind.no
Vårlid, Jostein	Lyse Produksjon AS	jostein.varlid@lyse.no
Wale, Erik	DNV	erik.wale@dnv.com
Warland, Leif	SINTEF Energiforskning AS	Leif.warland@sintef.no
Wedel, Signe Dahl	DONG Energy	sigwe@dongenergy.dk
Weider, Pia	Lyse Produksjon AS	pia.weider@lyse.no
Wenbin Dong	NTNU (student)	
Wenström, Jonas	Devold Amt	jw@amt.no
Westman, Bo	ABB	
Wickström, Anders	ScanWind	anders.wickstrom@scanwind.com
Yttervik, Rune	StatoilHydro	ruy@statoilhydro.com
Zachariassen, Espen	Markedskraft ASA	espen.zachariassen@markedskraft.com
Zhen Gao	NTNU (student)	
Øiseth, Ole Andre	NTNU	ole.oiseth@ntnu.no
Øverås, Ingrid	NTNU	ingrid.overas@hf.ntnu.no
Øvrebø, Sigurd	SmartMotor	sigurdo@smartmotor.no
Åhren, Thomas	MARINTEK	thomas.ahren@marintek.sintef.no
Aasheim, Erlend Eithun	NTNU	erlendei@stud.ntnu.no

Offshore vind: en gylden mulighet

Strategi for utvikling av offshore vindkraft, Terje Gjengedal, Vice President
Statkraft / Prof NTNU

Veikart for utvikling av offshore vind i Nordsjøen: EU-prosjektet WindSpeed,
Karina Veum, Senior policy adviser, ECN

Behov og nytte av koordinert forskning på offshore vindkraft,
John Olav Tande, Seniorforsker, SINTEF Energiforskning

Utvikling av det norske offshore vindmarkedet gjennom test og demonstrasjon
Kjell Olav Skjølsvik, Områdeleder Ny Teknologi, Enova SF

Offshore Wind Power

Terje Gjengedal
VP Statkraft
Professor at NTNU

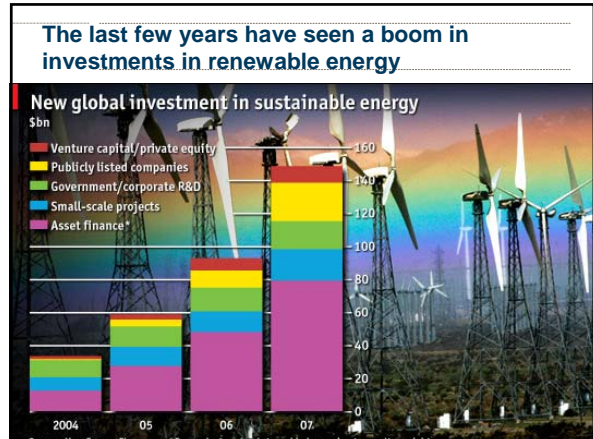
The leading wind power players

Company	Total MW	Onshore	Offshore
Vestas	5 210	5210	-
Acciona	2 701	2701	-
EDP	1 715	1715	-
Endesa	1 194	1194	-
EnBW	1 035	1035	-
E.ON	992	892	100
E.ON Energy Research Center	954	954	-
Enel	682	682	-
DONG Energy	626	275	351
Vattenfall	598	281	317
Statkraft	245	245	-



Driving forces for global trends

- Social
- Economic
- Political
- Environmental
- Technological





The EU Energy Policy..

20 20 20 - 2020

20% reduction in emission of greenhouse gases

20% improvement in energy efficiency

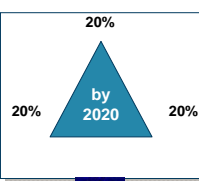
20% renewable energy





..FOLLOWED BY A "GREEN PACKAGE"

Communication on 20 20 in 2020

European Strategic Energy Technology Plan

Communication on energy efficiency

(New) Directive on European carbon trading



Directive on carbon capture and storage (CCS)

(New) Directive on renewable energy

Communication on carbon capture and storage (CCS)

Directive on carbon capture and storage (CCS)

(New) Directive on renewable energy

New state aid guidelines on environment



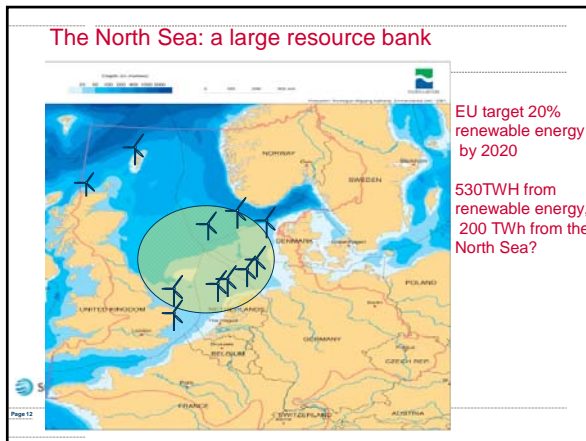
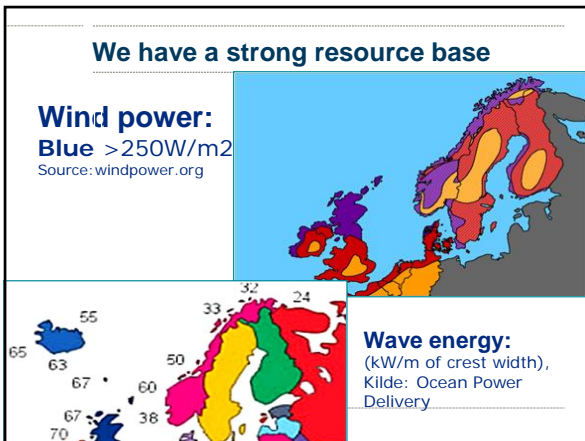
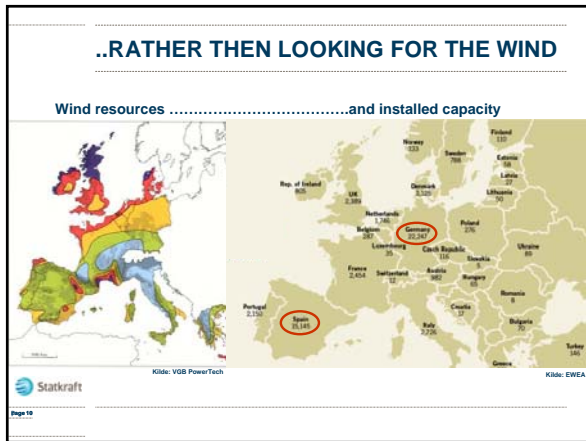
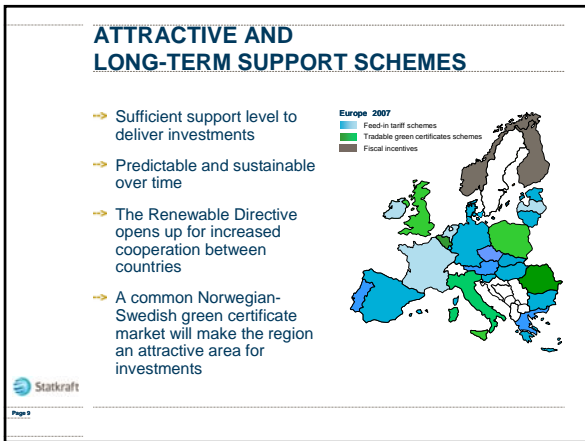
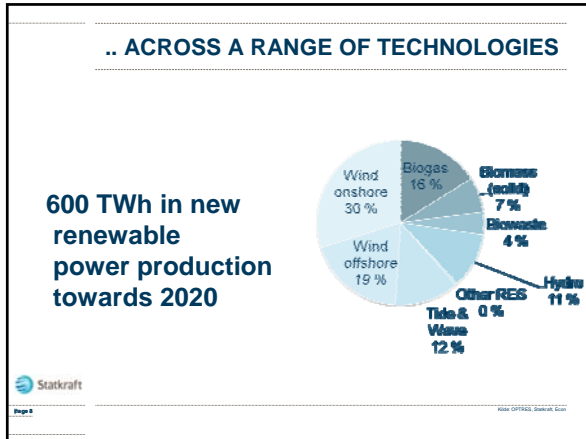
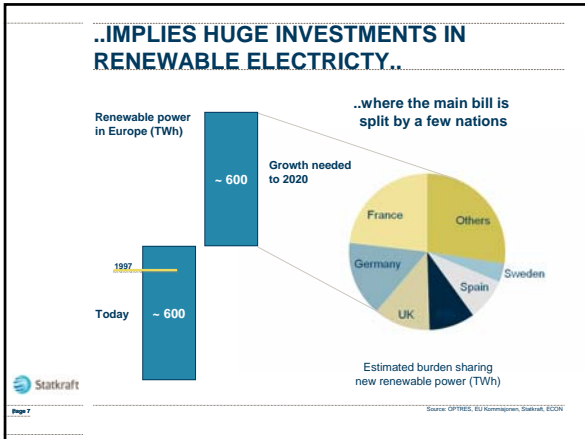

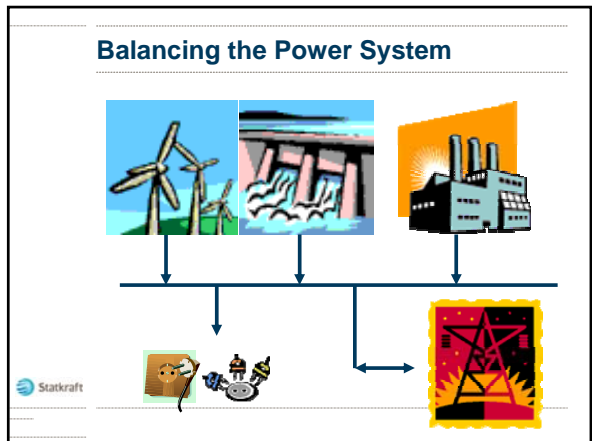
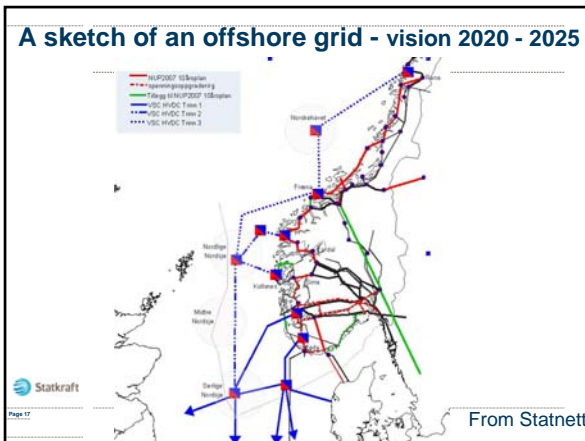
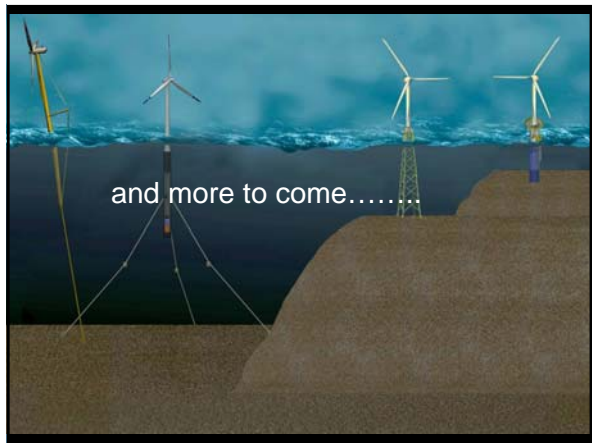

Some Important Issues

- Legislation
- Support schemes
- Technology
- Competence and experience
- Supply Chain
- Operations
- Market structure



STATKRAFT 2009

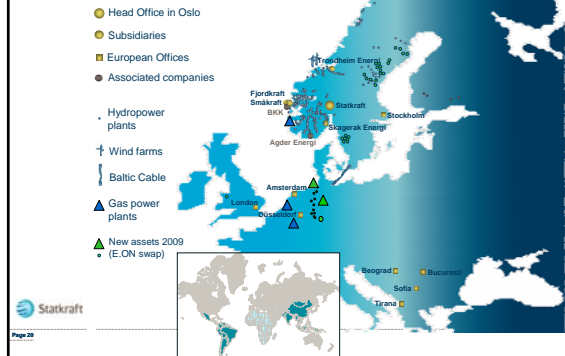

A FOCUSED STRATEGY WILL INCREASE THE LIKELIHOOD OF SUCCESS

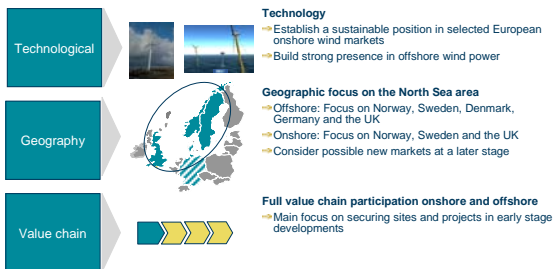

Technology development is necessary – but not sufficient

- Political will – and guts to act
- ..and money...



Veikart for utvikling av havbasert vindkraft i Nordsjøen:

"WINDSPEED" – Spatial deployment of offshore wind energy in Europe

Vindkraft FoU Seminar, Trondheim, 22. januar 2009
Karina Veum, ECN



www.windspeed.eu

Viktige prosesser og drivere i EU (1)

- Nytt direktiv med **bindende mål om 20% fornybarenergi** i EU innen 2020
- Bioenergi og vindkraft forventes å bli de viktigste bidragsyterne (EUs Veikart for fornybarenergi (COM(2006)848))
- Ny energipakke fra EU i November 2008 med nye signaler:
 - Kommunikasjon om havbasert vindkraft (COM(2008)768) – havbasert vindkraft kan økes med 30-40 ganger dagens installert kapasitet inn 2020, og opp mot 150 GW (~ 575 TWh) innen 2030 **men proaktiv politikk nødvendig**
 - Strategic Energy Review (COM(2008)...) – "a **Blueprint for a North Sea offshore grid** should be developed to interconnect national electricity grids in North-West Europe together and plug-in the numerous planned offshore wind projects"



Vindkraft FoU Seminar, Trondheim, 22. januar 2008

Viktige prosesser og drivere i EU (2)

- EU kommisjonen la i November 2008 fram en ny kommunisasjon - "Roadmap for Maritime Spatial Planning: "Achieving Common Principles in the EU" (COM (2008)791), der kommisjonen anerkjenner
 - økt aktivitet og konkurranse mellom sektorvise interesser i Europas maritime områder og
 - viktigheten av å balansere sektorinteressene gjennom arealplanlegging.



Vindkraft FoU Seminar, Trondheim, 22. januar 2008

Status for offshore vindkraft i noen land



Storbritannia:

- 566 MW installert kapasitet, 467 MW under konstruksjon
- To lisensrunder gjennomført, en 3. runde pågang – 25 GW
- Forbedret sluttordning
- Beatrice test site: 2 x 5 MW, 45 m havdybde, innovative løsninger

Nederland:

- 228 MW installert kapasitet, ingenting under konstruksjon
- Jobber nå med en maritime arealplan med mål om 6 GW innen 2020
- Inntil nå lite koordinasjon mellom sektorer og ustabil rammeverk

Belgia:

- 30 MW installert kapasitet, 90 MW under konstruksjon
- Har maritime arealplan
- Sektorvise konflikter har ført til store forsinkelser

Norge:

- 0 MW installert kapasitet
- Et betydelig potensial men mangel på rammeverk og gode insentiver
- Utvikler nye dyphavs prototyper: WindSea, Sway, Hywind
- Villig og klar til å investere i nett i Nordsjøen

Denmark:

- 414 MW installert kapasitet
- Har dagens største parker: Nysted (166 MW), Horns Rev (150 MW)
- TSO må etablere, finansiere og operere nett
- Handlingsplan for 23 x 200MW identifiserte områdene (4600 MW)

Germany:

- 0 MW installert kapasitet
- Nytt og forbedret rammeverk
- Pågående arbeid med å lage en maritime arealplan, men
- Alfa Ventus test område (5 MW turbines)



Vindkraft FoU Seminar, Trondheim, 22. januar 2008

Prosjektets målsetninger og oppgaver (1)

Prosjektet (strategiske) målsetninger er å:

- Bidra til en forbedret beslutningsprosess rundt utviklingen av havbasert vindkraft samt økt grad av koordinering og samarbeid mellom land
- Bidra til redusert konfliktnivå mellom sektorinteressene

Prosjektet skal:

- Utarbeide et veikart for utvikling av havbasert vindkraft i Nordsjøen (Sør og Sentral). Veikartet vil inkludere et ambisiøst men realistisk mål samt et sett av policy anbefalinger.

Videre skal prosjektet:

- Utvikle et GIS-basert og multi-kriteria beslutningsstøttesystem (DSS tool)



Vindkraft FoU Seminar, Trondheim, 22. januar 2008

Prosjektstrukturen:

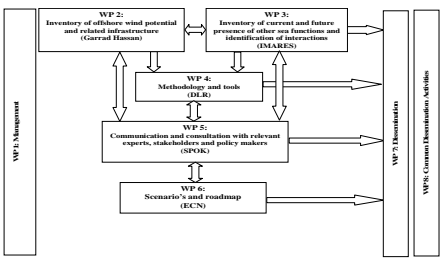

WP 2: Inventory of offshore wind potential and related infrastructure (Coastal Hazards)

WP 3: Inventory of current and future presence of other sea functions and identification of interactions (IMARES)

WP 4: Methodology and tools (DELIR)

WP 5: Communication and consultation with relevant experts, stakeholders and policy makers (SOPAC)

WP 6: Scenario's and roadmap (ECN)

WP 7: Dissemination

WP 8: Common Information System



Vindkraft FoU Seminar, Trondheim, 22. januar 2008

“Stakeholder” konsultasjon

Involvering av markedsaktører er viktig i EU prosjekter!

- Windspeed planlegger to set med workshops i flere land:
 - Innspill fra aktørene om funksjonaliteten til beslutningsstøtteverktøyet
 - Innspill i forhold til veikartet



Intelligent Energy Europe

Vindkraft FoU Seminar, Trondheim, 22. januar 2008

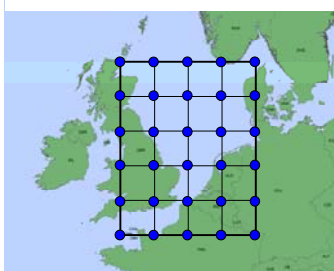

Intelligent Energy Europe

Vindkraft FoU Seminar, Trondheim, 22. januar 2008

Illustrasjon på kart i GIS:

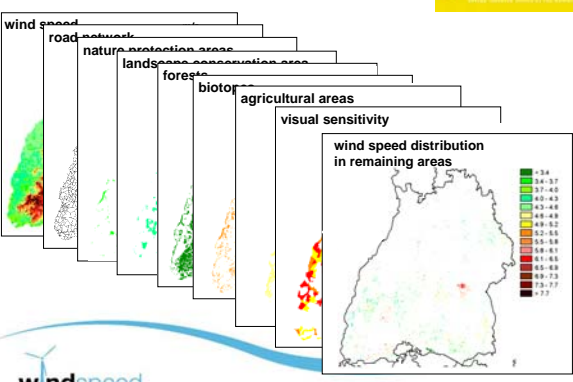

Intelligent Energy Europe

Vindkraft FoU Seminar, Trondheim, 22. januar 2008

Prosjektets timeplan:

Sep 2008 Feb 2011

Year 1 (12 months)	Year 2 (12 months)	Year 3 (6 months)
<ul style="list-style-type: none"> Complete inventories Quantifying impact of sea uses on other sea uses Develop methodological framework for DSS, defining input, output and functionality Stakeholder involvement 	<ul style="list-style-type: none"> Using DSS tool to generate GIS maps based on different development perspectives and allocation priorities Case studies with feedback from stakeholders Start work on scenarios and roadmap 	<ul style="list-style-type: none"> DSS training Finalisation of roadmap Dissemination of results

Intelligent Energy Europe

Vindkraft FoU Seminar, Trondheim, 22. januar 2008

Takk for oppmerksomheten!

For mer informasjon: www.windspeed.eu, veum@ecn.nl, korpas@sintef.no



Intelligent Energy Europe

Vindkraft FoU Seminar, Trondheim, 22. januar 2008

The need and value of coordinated research on offshore wind technology

John Olav Giæver Tande
 Senior Research Scientist / coordinator wind R&D
 SINTEF Energy Research
 John.tande@sintef.no

EU target 2020: 20 % renewable energy

Map: Airtricity

180 GW wind ~ 530 TWh/y ~ 15 % of EU el load

An offshore "SuperGrid" may provide for connection of offshore wind farms and efficient trans-national exchange of power

Norway can contribute with hydro for balancing, but also take active part in an offshore wind development

50 GW offshore wind means investments of about EUR 125 billions

Offshore wind farms are being developed

Total installed offshore wind by 2007: 1100 MW
 ▲ Operational offshore wind farms
 + Offshore wind projects to be built in 2008-2009

www.ewea.org

Norway is developing offshore wind technology

Offshore wind technology needs to be developed

- Technology must be developed for improved reliability and reduced cost
- The whole value chain can be improved:
 - Design
 - Manufacturing
 - Installation
 - Grid connection and system integration
 - Operation and Maintenance
- Technical issues can be solved
- R&D must be go in parallel with test, demonstration and large scale implementation

Cost of offshore wind energy

1 EUR = 8 NOK

Tower top weight is critical for keeping the cost down

Strong labs and experience on wind within NTNU, SINTEF and IFE

Wind tunnel (11x3x2 m) Ocean basin (80x50x10 m) Renewable Energy Systems Lab Material testing



Test station for wind turbines – VIVA AS
Average wind speed 8.4 m/s @ 50 m agl





Photo / Visualisation: InterPares AS

NTNU IFE SINTEF

Vision: Large supply from offshore wind turbines



- Large scale commercial use of floating offshore wind turbines is viable by year 2020 – shallow water wind farms can be built now
- Share infrastructure: Wind generation for supply to oil and gas platforms, mainland grid and trans-national connections
- Big potential for industrial development - Use Norwegian oil and gas industry know-how
- The market is global and growing
- Clean renewable supply at competitive cost replacing polluting generation and reducing emissions (CO₂, NO_x)

NTNU IFE SINTEF



Utvikling av det norsk offshore vindkraftmarkedet

Vindkraft FoU Seminar
Trondheim, 22. januar 2009

Drivkraft for fremtidsrettede energiløsninger



Utgangspunktet:

Vi har et godt utgangspunkt

- Ressursgrunnlaget er stort
- Industrien har offshore/marin kjernekompetanse

Enova har et vidt perspektiv

- Enovas hovedformål er å fremme en miljøvennlig omlegging av energibruk og energiproduksjon.
- Energiomleggingen er en langsiktig satsing på utviklingen av markedet for effektive og miljøvennlige energiløsninger som bidrar til å styrke forsyningsikkerheten for energi og redusere utslippene av klimagasser
- Enovas resultatmål er 18 TWh spart og produsert ny fornybar energi innen utgangen av 2011 og 40 TWh innen 2020
- Budsjett: ~1,5 mrd. kr pr år



Samlet ambisjonsnivå er høyt

Mange parker er meldt/konsesjonssøkt:

- Lofoten havkraftverk – Lofotkraft vind, 750 MW
- Selvær – Nord-Norsk Vindkraft, 450 MW
- Aegir – Fred Olsen Renewables, 1200 MW
- Fosen Offshore vindpark (OVAS), 600 MW
- Mørevind – TrønderEnergi, 1200/800 MW
- Stadtvind – Vestavind kraft, 1080 MW
- Utsira – Lyse, 25+275 MW
- Siragrunnen – Siragrunnen AS, 200 MW
- Idunn – Fred Olsen Renewables, 999 MW
- Sørlige Nordsjøen – Lyse, 1000 MW

Illustrasjon av utfordring knyttet til kostnadene

Mulighetsstudie NVE/Enova:
17-22 TWh landbasert vindkraft mulig innen 2025

Teknisk realiserbar utbygging av landbasert vindkraft 12015 og 2025

Anta case: 15 TWh ny vindkraft

Landbasert vindkraft:
CAPEX 13,7 – 15,5 mill/MW,
OPEX 13 øre/kWh
(Kilde: Gerrad Hassan/Enova, 2008)

Utbygging: 5000 MW
Totale investeringer: 80 mrd.
Støttebehov: 22 mrd.

Alternativer for 15 TWh

Bunnsfast Offshore vindkraft:
CAPEX 22 - 24 mill/MW
OPEX 22 øre/kWh
(Kilde: Potensialstudie havvind, Enova, 2007)

Utbygging: 4250 MW
Totale investeringer: 100 mrd.
Støttebehov: 46 mrd. NOK

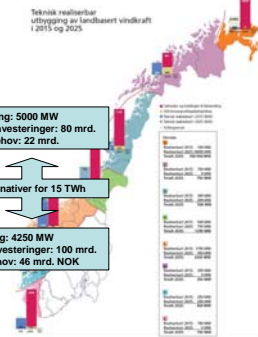
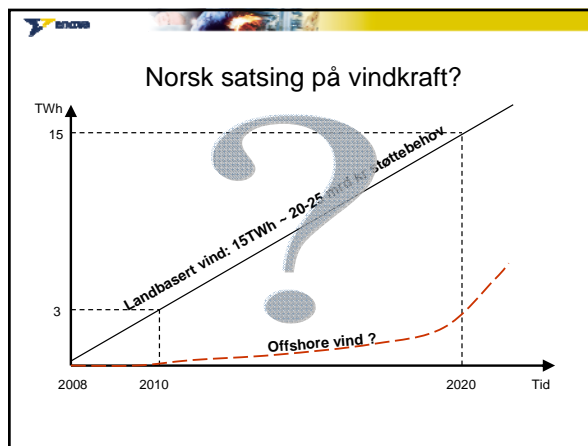
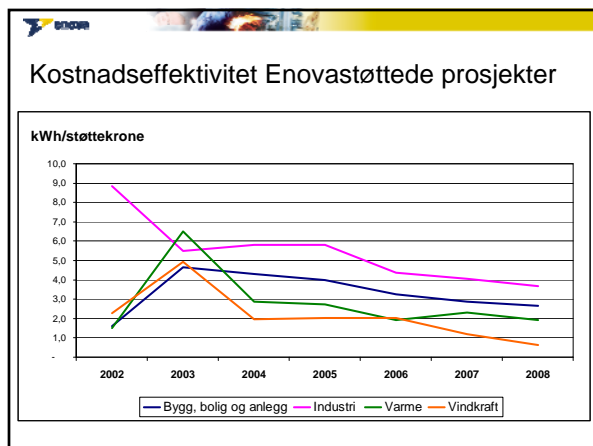

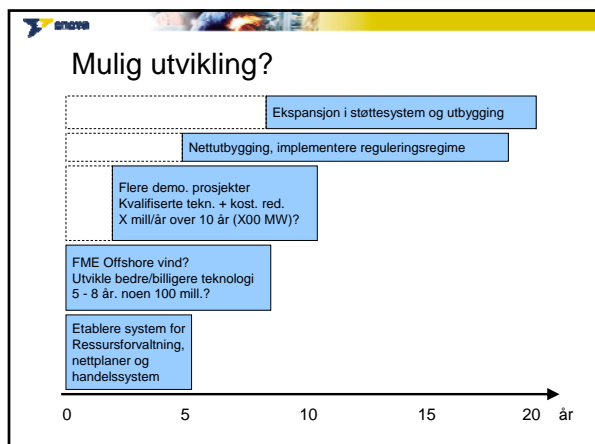
Hva vil Enova gjøre?

- Enovas vindkraftprogram
 - Mål: 3 TWh i 2010
 - Om lag 3 mrd 2008 – 2010
 - Ny utlysning ultimo februar 2009
- Tematisk satsing offshore kraftproduksjon
 - Under utvikling
 - Lansering under Energiuka 2009

Takk for oppmerksomheten

For mer informasjon: www.enova.no

Nye konsepter og teknologi

Lange blader for offshore turbiner, Jørg Høyland, PhD student NTNU

Individuell pitch av vindturbinblader, Fredrik Sandquist, PhD student NTNU

Svingninger i vindturbinunderstell, Paul Thomassen, Post doc NTNU

SmartBlades for offshore vindturbiner, Andreas Knauer, Forsker IFE

Model tests of turbine in yaw condition, M. S. Adaramola, Post doc NTNU

BEM rotor analyses vs. Measurements, Karl Merz, PhD student NTNU

Truss towers for offshore wind turbines, Haiyan Long, PhD student NTNU

Regulering av flytende vindturbiner, Thomas Fuglseth, PhD student NTNU

Korrosjonsbeskyttelse av vindturbiner, O Knudsen, Seniorforsker SINTEF MK

Optimalisering av flyter og ankersystem, Seniorforsker I. Fylling, MARINTEK

Teknologiskifte for store vindturbinblad

Presentasjon av PhD-stud
Jörg Höyland



NTNU

Vindkraft FoU seminar 2009

Introduksjon Større vindturbiner Datamodell Test av 6m bjelke



Veiledere: Andreas Echtermeyer
Nils Petter Vedvik

Start: April 2004
Ferdig: Februar 2009

NTNU

Vindkraft FoU seminar 2009

1

Introduksjon Større vindturbiner Datamodell Test av 6m bjelke

Problemstilling

- Hvor trykker skoen i dag?
- Hvilke utfordringer har fremtidens vindturbinblad?
- Hvor kan vi bidra?

NTNU

Vindkraft FoU seminar 2009

2

Introduksjon Større vindturbiner Datamodell Test av 6m bjelke

En dobling av bladlengden vil firedoble energien tilgjengelig.

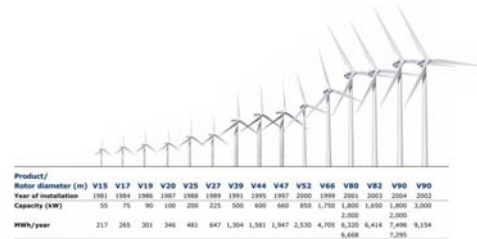

NTNU

Vindkraft FoU seminar 2009

3

Introduksjon Større vindturbiner Datamodell Test av 6m bjelke

Installasjonskostnader offshore

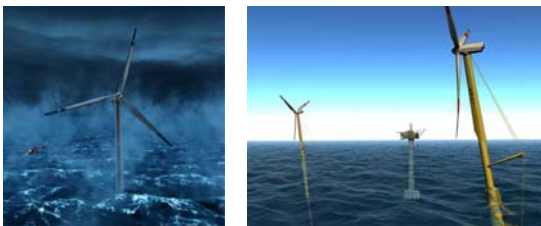

NTNU

Vindkraft FoU seminar 2009

4

Introduksjon Større vindturbiner Datamodell Test av 6m bjelke

Bladets masse

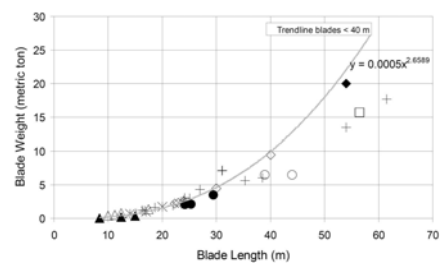

NTNU

Vindkraft FoU seminar 2009

5

Introduksjon Større vindturbiner Datamodell Test av 6m bjelke

Bladets utbøyning



NTNU

Vindkraft FoU seminar 2009 6

Introduksjon Større vindturbiner Datamodell Test av 6m bjelke

Bladets oppbygging

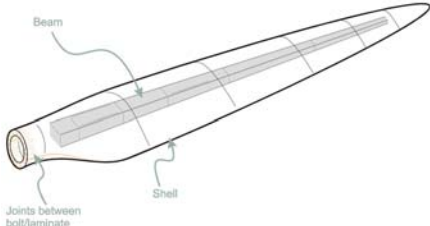

NTNU

Vindkraft FoU seminar 2009 7

Introduksjon Større vindturbiner Datamodell Test av 6m bjelke

Bladets oppbygging

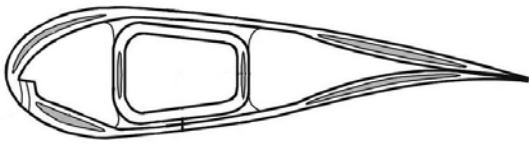

NTNU

Vindkraft FoU seminar 2009 8

Introduksjon Større vindturbiner Datamodell Test av 6m bjelke

Datamodell

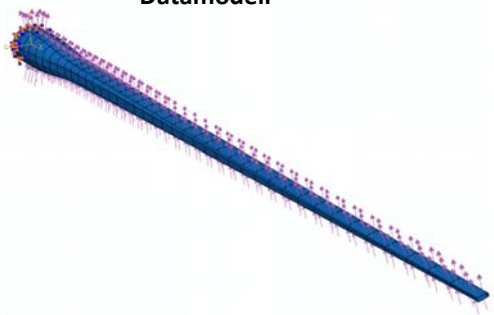

NTNU

Vindkraft FoU seminar 2009 9

Introduksjon Større vindturbiner Datamodell Test av 6m bjelke

Lasttilfelle

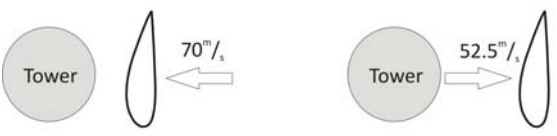

a) Primary load case b) Secondary load case

NTNU

Vindkraft FoU seminar 2009 10

Introduksjon Større vindturbiner Datamodell Test av 6m bjelke

Materialvalg

- Glass fiber
- Karbon fiber
- Karbon og glass

Hvordan påvirker materialvalg vekt og pris?

NTNU

Vindkraft FoU seminar 2009 11

Introduksjon Større vindturbiner Datamodell Test av 6m bjelke

Definere materialer i FEM modell

NTNU

Vindkraft FoU seminar 2009 12

Introduksjon Større vindturbiner Datamodell Test av 6m bjelke

Analyse av spenninger

NTNU

Vindkraft FoU seminar 2009 13

Introduksjon Større vindturbiner Datamodell Test av 6m bjelke

Analyse av stabilitet (bukling)

Ikke-lineær metode

Lineær metode

NTNU

Vindkraft FoU seminar 2009 14

Introduksjon Større vindturbiner Datamodell Test av 6m bjelke

Resultater for 100m vindturbinblad

Material	Vekt [tonn]	Pris [Euro]
Karbon	41.2	955 000
Karbon/glass	62.6	630 000
Glass	114.5	259 000

NTNU

Vindkraft FoU seminar 2009 15

Introduksjon Større vindturbiner Datamodell Test av 6m bjelke

Pitch kontroll for å begrense last

a) Load case 1

b) Load case 2

NTNU

Vindkraft FoU seminar 2009 16

Introduksjon Større vindturbiner Datamodell Test av 6m bjelke

Effekten av pitch kontroll under ekstrem last

Root bending moment [MNm]

Position along blade [m]

Blade with no pitch control

Blade with pitch control

NTNU

Vindkraft FoU seminar 2009 17

Introduksjon Større vindturbiner Datamodell Test av 6m bjelke

Resultater for 100m vindturbinblad med pitch kontroll

Material	Vekt [tonn]	Endring vekt [%]	Pris [Euro]	Endring pris [%]
Karbon	40.2	-2.4	932 000	-2.4
Karbon/glass	65.5	4.6	476 000	-24.4
Glass	75.6	-33.9	171 000	-33.9

NTNU Vindkraft FoU seminar 2009 18

Introduksjon Større vindturbiner Datamodell Test av 6m bjelke

Datamodell

=

Virkeligheten?

NTNU Vindkraft FoU seminar 2009 19

Introduksjon Større vindturbiner Datamodell Test av 6m bjelke

Labforsøk av 6m bjelke

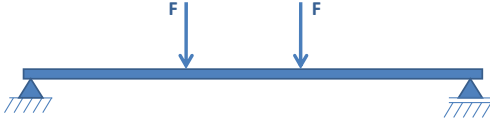

NTNU Vindkraft FoU seminar 2009 20

Introduksjon Større vindturbiner Datamodell Test av 6m bjelke

6m bjelke i glassfiber



NTNU Vindkraft FoU seminar 2009 21

Introduksjon Større vindturbiner Datamodell Test av 6m bjelke



NTNU Vindkraft FoU seminar 2009 22

Introduksjon Større vindturbiner Datamodell Test av 6m bjelke

Strekklapper og optiske målepunkt



NTNU Vindkraft FoU seminar 2009 23

Introduksjon Større vindturbiner Datamodell Test av 6m bjelke

Test av 6m bjelke



NTNU

Vindkraft FoU seminar 2009 24

Takk for oppmerksomheten ☺

Spørsmål?

NTNU

Vindkraft FoU seminar 2009 25

Individual Pitch Control of Wind turbines

Fredrik Sandquist
PhD student, NTNU

Variable Speed Pitch Controlled Wind Turbines

- Control inputs
 - Blade pitch angles
 - Turbine torque
- Operation regions
 - Region 1, 2 and 3

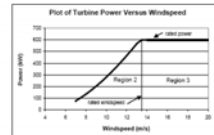

Control Strategies

- Region 2: Maximum power
 - Constant tip speed ratio
 - Collective pitch constant
 - Variable torque
- Region 3: Constant speed and power
 - Variable pitch
 - “Constant” torque

Load Reduction

- Load reduction
 - Drive train
 - Blade load, mostly flap
 - Tower
- Loading
 - Gravity
 - Wind
- Periodic loading
 - Gravity
 - Wind shear
- Almost periodic loading
 - Wind gusts

Method

- Nonlinear aero elastic dynamic model of the entire turbine
- Linearize the model around an operation point
 - Azimuth varying linear model
- Apply the Coleman transformation on the linear model
 - (Almost) time invariant linear model
- Apply multivariable control theory on the linear model

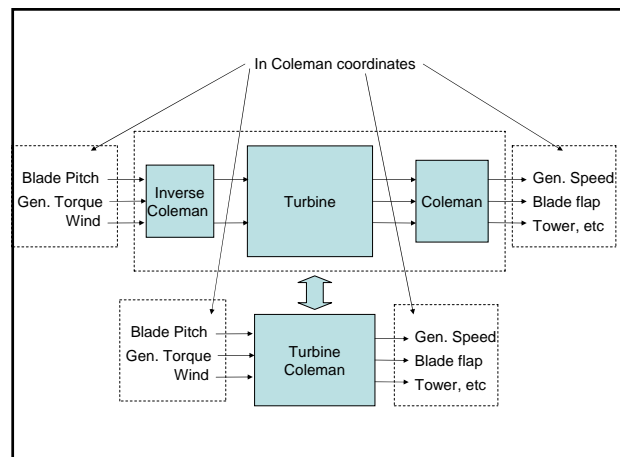

Diagonal PID controller

- Measure generator speed and individual flap (2 signals)
- Control inputs collective and individual pitch
- The wind turbine is close to diagonal

Transfer function to speed

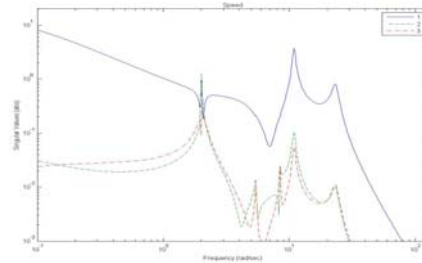

Transfer function to horizontal flap

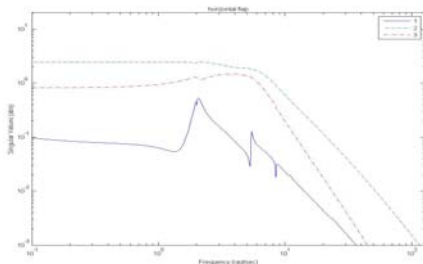

Transfer function to vertical flap

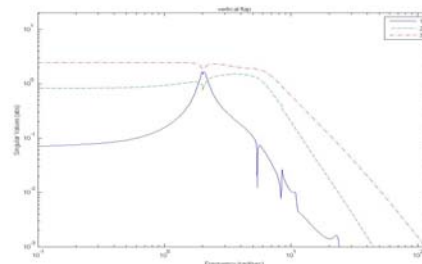

Interactions

- Not much interaction between generator speed and individual pitch
- Not much interaction between individual flap and collective pitch
- Some interactions between the two individual channels
- There are interactions between all signals at 2 rad/s, this is due to the tower

Controller

- A diagonal controller can be good
- The individual flap is easy to control with a PID controller
- The generator speed is more difficult to control
 - Zeros in the right half plane
 - Low phase
 - Resonant peaks at high frequency
- A PI regulator and notch filters at the resonant peaks works good
- This controller works good but it is possible to achieve better performance with other controllers.

The transfer function from collective flap to generator speed

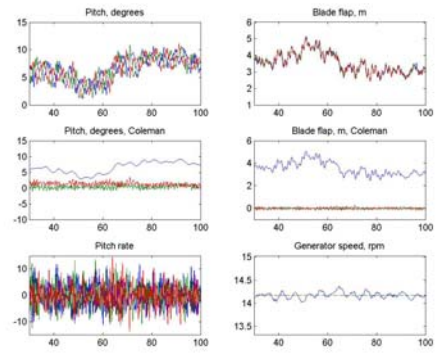
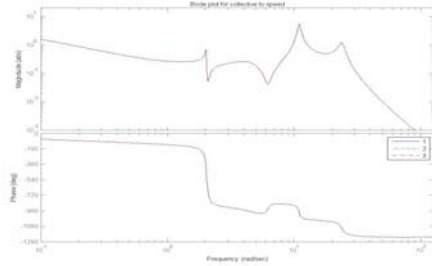

1

Svingninger i vindturbinunderstell

- Professor Geir Moe
- Post.doc. Paul Thomassen



www.ntnu.no

2

Agenda:

1. Dragkrise svingninger
 - er drag krise svingninger i havstrøm aktuelle for offshore vindturbiner?
2. Hvis tid: IEA Wind, Annex XXIII



www.ntnu.no

3

Mange typer av svingninger i strøm

- Hvirvelinduserte svingninger
- Galloping
- etc...



www.ntnu.no

4

Dragkrise induuerte svingninger

- Den klassiske drag formelen: $F_{\text{Drag}} = C_D \frac{1}{2} \rho D U^2$
- Drag koeffisienten C_D er en funksjon av Reynoldstall: $Re = \frac{DU}{\nu}$

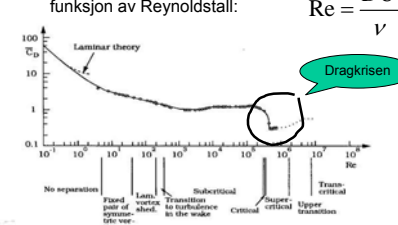

- Gjelder glatt sylinder i konstant strøm, se Sumer og Fredsøe (1997)



www.ntnu.no

5

Dragkrise område

- Experimentelle resultat, Schewe(1983):

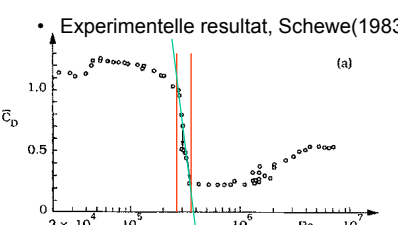



- $2.7 \times 10^5 < Re < 3.5 \times 10^5$
- C_D reduseres med ca 75%



www.ntnu.no

6

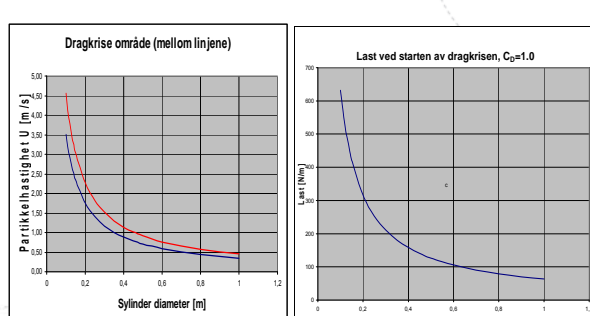
Dragkrise området

www.ntnu.no

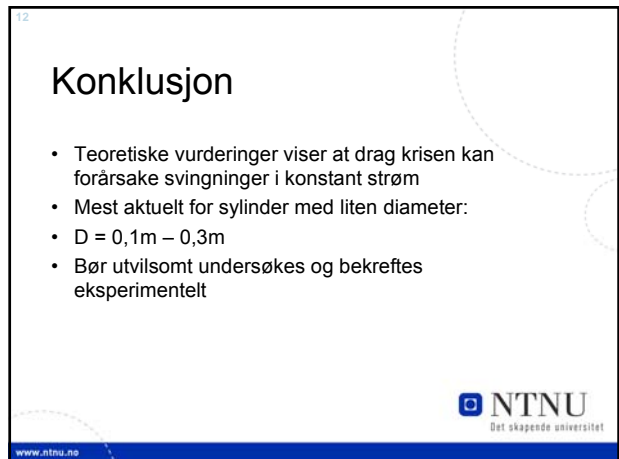
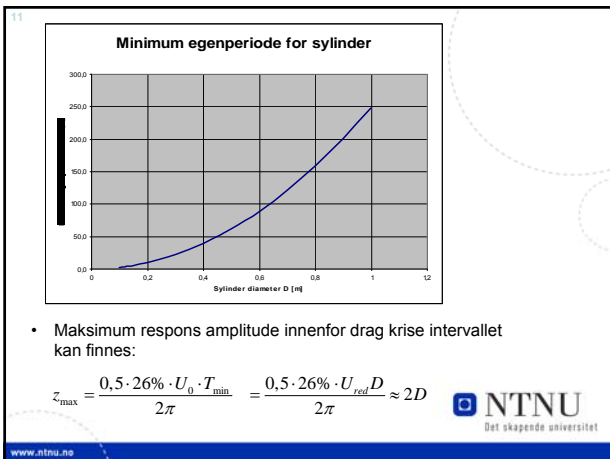
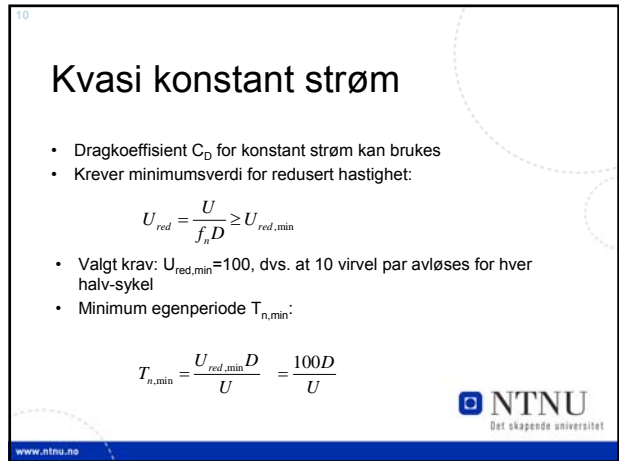
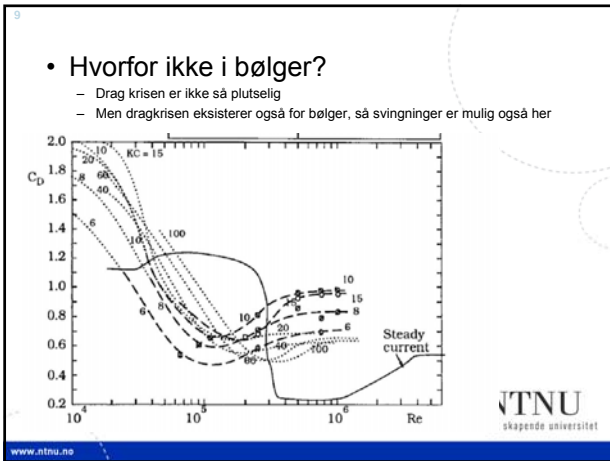
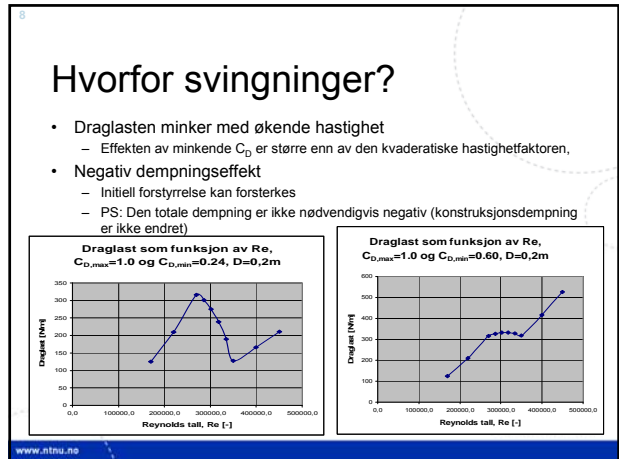
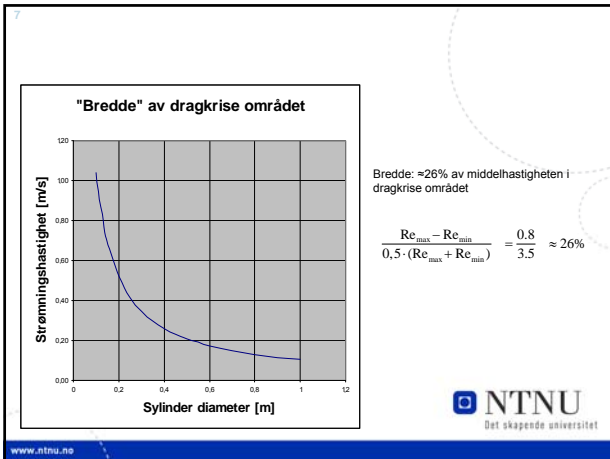

13

IEA Wind Annex XXIII - Subtask 2: Benchmark for aero-elastic software for offshore vind turbiner

- IEA Wind Annex 23: www.ieawind.org/Annex_XXIII.html
- Software:
 - GH Bladed (Harrad Hassan, UK)
 - HAWC2 (Risø, Danmark)
 - FLEX5 (DTU, Danmark)
 - FAST/ADAMS (NREL/MSU, USA)
 - Kommer (?): MARINTEK, Trondheim
- Hydrodynamikk:
 - Morrison
 - (Lineær potensialteori)

 NTNU
Det skapende universitet

www.ntnu.no

14

4 faser

- Fase 1: Monopile, fast innspent
 - Avsluttet: "OC3 - Benchmark Exercise of Aero-elastic Offshore Wind Turbine Codes", Passon et. al. (2007)
- Fase 2: Monopile, fleksibel innspenning
 - Avsluttet: "Pase II Results Regarding Monopile Foundation Modeling", Jonkman et. al. (2008)
- Fase 3: Tripod med pæler
 - Under avslutning, publisering i vår
- Fase 4: Flytende vind turbin: Variant av Hywind
 - Under oppstart

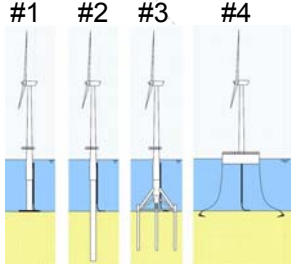

 NTNU
Det skapende universitet

www.ntnu.no

15

Vi skal utnytte solen og vinden og jorden for å gi drivstoff til våre biler og drive våre fabrikker.

Barack Obama, 20. januar 2009

 NTNU
Det skapende universitet

www.ntnu.no

Smart-blade teknologi

Andreas Knauer, Roy Stenbro
IFE

2009-01-27



Smart-blade teknologi

- Introduksjon
- Laster og kontroll av vindturbin
- Mulige konsepter for løftkontroll
- Første resultater
- Videre arbeid

2009-01-27



Effektkurve

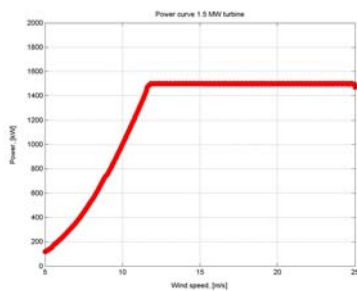

Effektkurve

- Start ved 5 m/s
- 1.5 MW ved 12 m/s
- Pitching for vind > 12 m/s
- Stopp ved 25 m/s

2009-01-27



Rotoraerodynamisk effekt

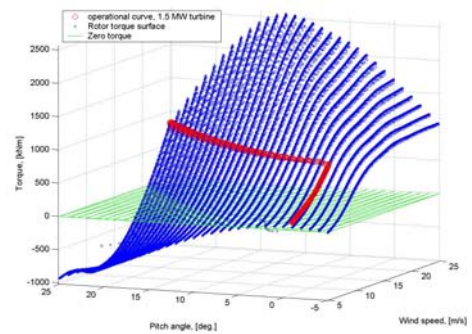

2009-01-27



Vindturbinlaster

Extreme operating gusts (EOG):

- Dimensjonerende last for blader
- Fort vindhastighetsendring med AOA endring
- Resultat: ekstreme løftkrefter danner torque og thrust ekstrema

Nyttig:

En effektiv metode for rask **løftreduksjon**

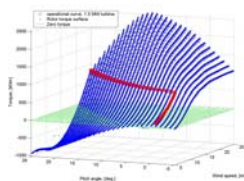
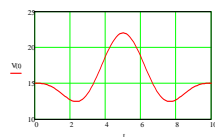

2009-01-27



Vindturbinlaster

Turbulens:

- Utmattingslast for blader
- Vindhastighetsendring med AOA endring
- Resultat: variasjon av torque, thrust og energiproduksjon

Hva trengs:

En effektiv metode for rask **løftmodifikasjon**

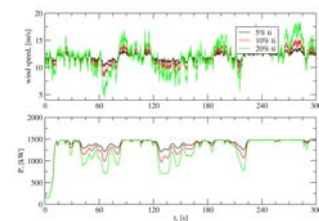

2009-01-27



Smart-blade teknologi

Blader for turbiner i 5 MW-klassen har lengder > 60m og masser > 15 tonn.
 Kontroll av store rotorer er en utfordring og utvikling av smart-blade teknologi kan øke turbinens operasjonstid og ytelse.
 Mål for utviklingen:
 • Teknisk og økonomisk effektiv
 • 'Adaptivity from Aerospace'
 • Pålitelighet fra vindenergi

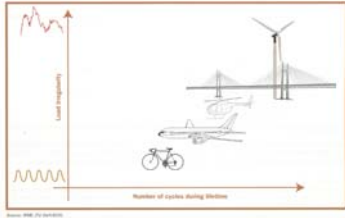

2009-01-27



Noen alternativer for løftmodifikasjon

- Flaps (strukturmodifikasjon, 'reliability')
- Slots (strukturmodifikasjon, 'reliability')
- Add-ons (lite masse, BL modifikasjon, smart materials?)
- Ventilation (BL-modifikasjon, 'viscous' flap)

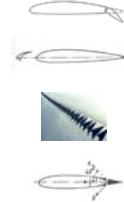

2009-01-27



Eksempel: evaluering av flap

- Foil data:
- Profil: NACA 4412
 - Flap: 90 til 100% kordelengde
 - Utslag: +/- 10 grader
 - COR: $x=0.9c$, $y=0.0122c$

Operasjon ved $Re=4e6$, 'Fixed transition' ved $0.05\%c$ t/b

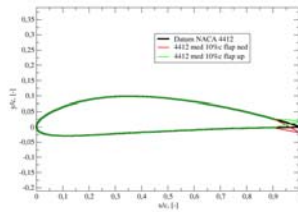

2009-01-27



Evaluering av flap

- Resultater fra XFOIL:
- Kraftige løftendringer i hele operasjonsområdet
 - Kraftige dragendringer, spesielt for store AOA
- Designpunkt:
- +19% og -26% løft
 - +25% og -12% drag

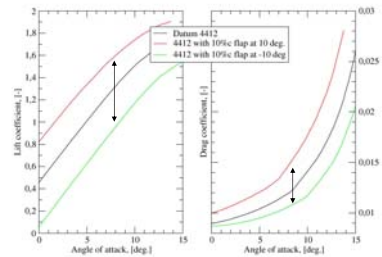

2009-01-27



Evaluering av flap

Aerodynamisk ytelse

L/D ratio:

- Datum: 112
- Flap ned: 106.6
- Flap opp: 93,2

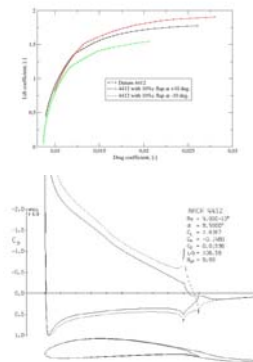

2009-01-27



Evaluering av flap

Grensesjikt og stabilitet:

- Flaps viser sterk innflytelse på grensesjikt – lokalt
- 'Krümmingsprung' er et kritisk område
- Fare foravløst strøming

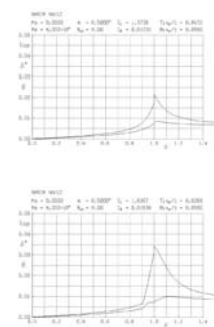

2009-01-27



Potensial flaps

- Løftendringer modifierer thrust- og torque / energiproduksjonen direkte
- Stort potensial for lastreduksjon (Adapwing prosjekt/Risø, ECN/DUT)
- Veldig interessant som supplement til konvensjonell kontrollmetode

Design som konvensjonell eller ikke-konvensjonell smart-blade flap er en utfordring.

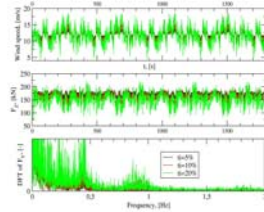

2009-01-27



Smart-blade teknologi

Identifikasjon av de beste aerodynamiske konseptene for:

- Damping av laster og vibrasjoner
- Stabilisering av strømningsbildet
- Avlastning av konvensjonell pitch-kontroll
- Offshore floating turbine applikasjoner

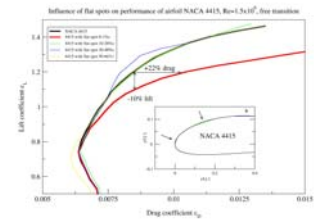

2009-01-27



Teknologiutvikling Smart-blade

Utfordringer:

- Identifikasjon og design av robuste og effektive aerodynamiske konsept
- Check/Utvikling av egnete foilformer
- Utvikling av nye aktuatorer og materialer
- Utvikling av sensorer og kontroll-algorithmer
- Utvikling/modifikasjon av numeriske verktøy
- Integrasjon av alt i et design

2009-01-27



Konklusjon

Forskning med smart-blade teknologi er i en tidlig fase. Første aktiviteter fokuserer her på aerodynamikk; flere andre fagfelter vil bli involvert.

Første resultater og erfaringer fra andre prosjekter gir en tydelig indikasjon på at mer avansert kontroll av rotorens aerodynamikk med smart-blade teknologi har et potensial for å:

- forbedre ytelsen i hele operasjonsområdet
- utvide operasjonsområdet
- støtte eller avlaste eksisterende kontrollkonsept

Design av et effektivt, robust system er en utfordring for alle involverte fagfelter.

2009-01-27



MODEL TESTS OF WIND TURBINE IN YAW CONDITION

Muyiwa S. Adaramola and Per Åge Krogstad

DEPT. OF ENERGY AND PROCESS ENGINEERING
NTNU, NORWAY

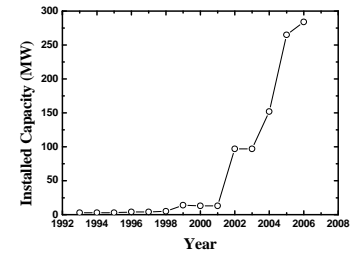
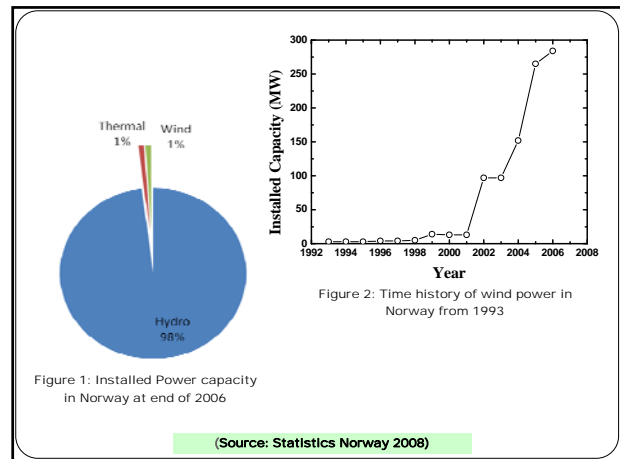

Wind Energy

Why wind energy?

- Economic
- Environment
- National Security
- Huge Potential

Classification

- Onshore energy
- Offshore energy
 - Shallow water
 - Deep water (Depth > 30 – 50 m)

Deep sea offshore challenges

- Foundation – floating type
- Connection to grid
- Installation and maintenance
- Dynamic stability

Implication of Floating foundation

- Turbine operating more in yaw and tilt conditions

Why Offshore Energy For Norway?

- Available potential
- Limited shallow water along the coastal region
- Gas thermal and nuclear stations not options
- High demands in winter season when wind resources are good
- Income generation
- Help EU to meet and exceed their target
- Create and improve expertise in deep sea energy technology

Definition of Terms

- U = Freestream velocity (m/s)
- R = Rotor radius (m)
- P = Rotor power (W)
- T = Thrust (N)
- Ω = Rotor speed (rad/s)
- $\lambda = \Omega R / U$ (Tip Speed Ratio)
- $C_p = \frac{P}{0.5 \rho \pi R^2 U^3}$
- $C_Q = C_p / \lambda$
- $C_T = \frac{T}{0.5 \rho \pi R^2 U^3}$
- γ = Yaw angle (Degree)
- θ = Flow angle (Degree)

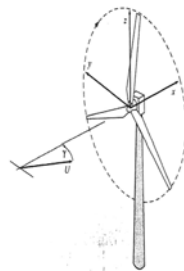

Turbine yawed to the wind direction

Model Wind Turbine



Blade Dimensions

- Radius – 400 mm
- Tip chord – 27.65 mm
- Root chord – 61.0 mm
- Solidity ratio – 9.38 %

Hub Parameters

- Diameter – 90 mm
- Height – 800.0 mm

Solid blockage – 10.34%

Experimental Set-up

Wind Tunnel

- Test section: 1.8 m (height) x 2.7 m (width) x 11.0 m (length)
- Wind speed: Up to 30 m/s
- Turbulence intensity: 0.2%

Model Location

- Centreline of the wind tunnel and 560 cm from the flow entrance.
- Yaw angle varied from 0 to 30 degrees.

Wind Velocity

- Pitot-static pressure probe
- 6, 8 and 10 m/s

Rotor speed

- Monitored and controlled by SIEMENS voltage inverter
- Varied between 15.6 rad/s and 156.9 rad/s

POWER COEFFICIENT - Re Effect

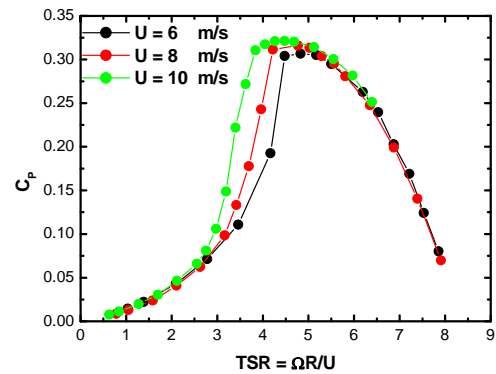

THRUST COEFFICIENT - Re Effect

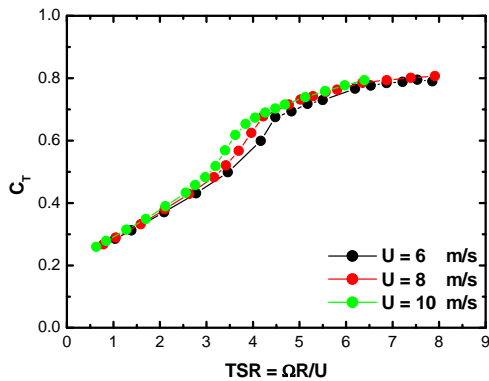

POWER COEFFICIENT - Yaw Effect

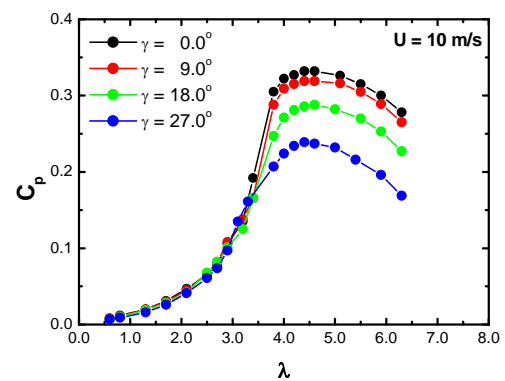

Yaw Effect

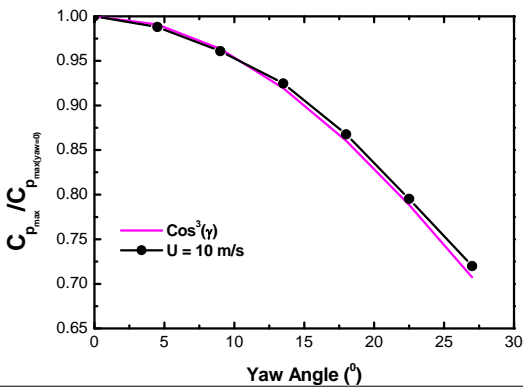

TORQUE COEFFICIENT - Yaw Effect

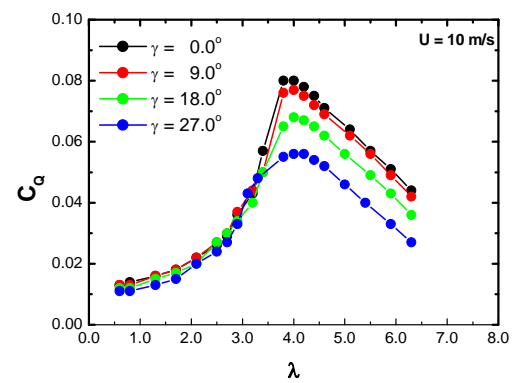

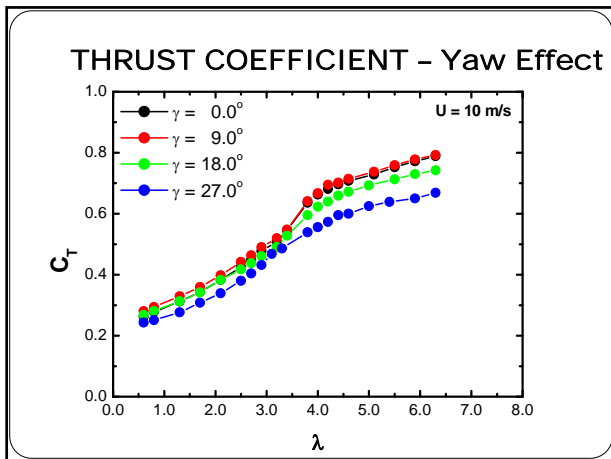

SUMMARY

- With increasing yaw angle, both thrust and power output reduces.
- Strong implication on floating type wind turbine.
- Better estimate of energy production.
- Design strategy to reduce the yaw effect need to be considered.

Verification of the Blade Element Momentum Method:
Be Careful of Data Extrapolation

Karl Merz
Bygg, Anlegg, og Transport
NTNU

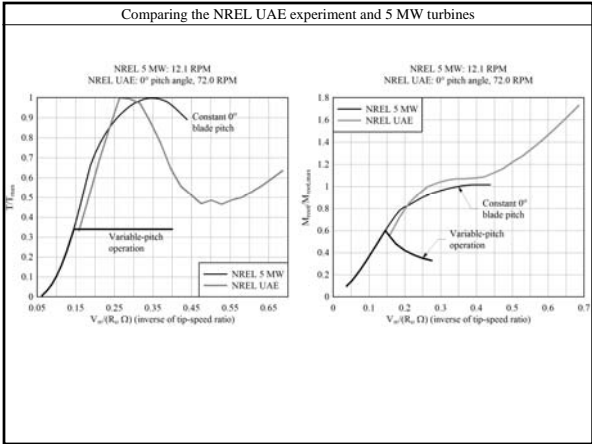
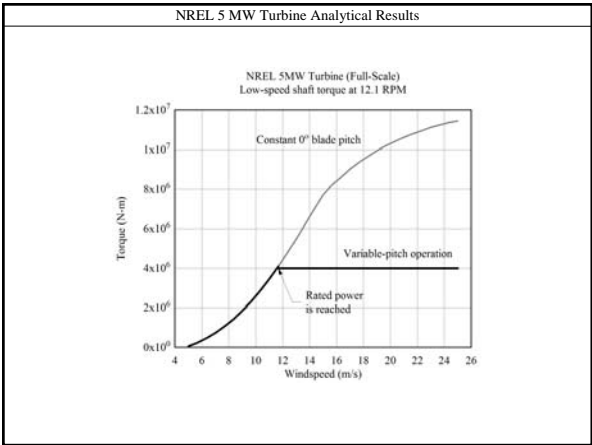
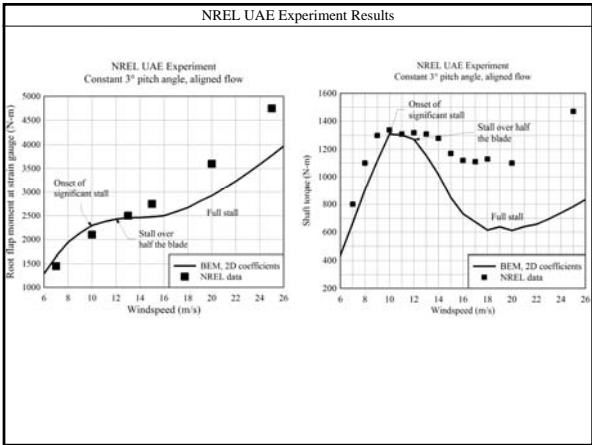
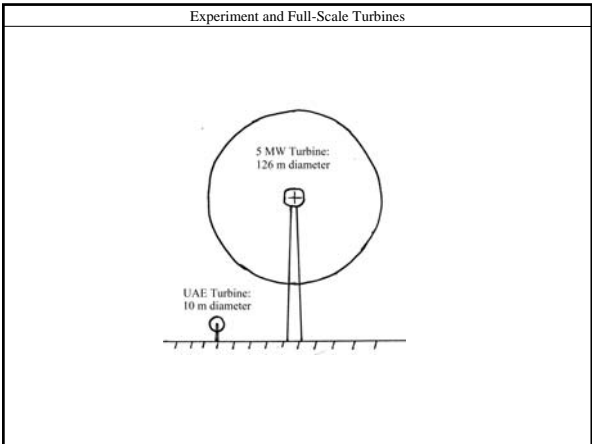

Conclusions

The regimes of operation of the model test and full-scale turbine do not overlap.

The pitch-controlled 5 MW turbine does not experience stall over the outer portion of the blades during normal operation.

For the 5 MW turbine, it is expected that the BEM method will calculate loads and power output with sufficient accuracy for design.

Truss Support Structures in Offshore Wind Turbines

Haiyan Long, Geir Moe
Department of Civil and Transport Engineering, Norwegian University of Science and Technology,
7491 Trondheim, Norway

NTNU
Norwegian University of
Science and Technology

www.ntnu.no

Contents

1. Possible Designs for OWTs' Support Structure
2. Advantages of Truss towers over Tubular ones
3. Challenges of Truss towers
4. Preliminary Design of TrussTower
5. Fatigue Analysis
6. Ongoing Work

Truss Support Structures in OWTs

1. Offshore Wind Turbines Design

Fig.1 Offshore Wind Turbine Designs

Truss Support Structures in OWTs

2. Advantages of Truss towers over Tubular ones

- Material saving → economic solution
Material saving up to 50% in 4 legs-truss towers with same stiffness.
- Sound mechanism
Stress from axial forces >> from moments → high structure (deep water)
Stiffness mainly dependent on distance → Less wave force

Fig.2 Entire Wind Turbine Models with the towers of difference types

Truss Support Structures in OWTs

2. Advantages of truss towers over Tubular ones

- More Options for Towers' Topology
Inherent stability, less joints, more economic, simpler construction process

Fig.3 Truss towers with different topology

Improvement in brace types

Capacity of resisting torsion dependent on the size of cross section
Possibility to decrease the number of joints

Truss Support Structures in OWTs

2. Advantages of Truss towers over Tubular ones (continues)

- Open space
 - Less wave loads and wind load on structure bodies
 - More potential for the use of downwind turbines
 - More options for foundation due to multi-leg config.
 - Less effect between piles
- Possibility for economic foundation solutions
 - suction pile

Fig.4 Suction pile

- Advantage over suction caisson:
 1. Fast and economic.
 2. Small demand for hammering equipment
 3. High capability to withdraw the overturning moment than suction caisson
 4. Get popular in offshore oil field

Truss Support Structures in OWTs

3. Challenge of truss towers over Tubular ones

- Complex fabrication
 - Optimize the configuration to reduce the joints' number
 - Reduce the process of fabrication AMAP
 - Refer to the relative technology in offshore oil (to contact with industry)
- Dependence on wind orientation due to asymmetric section
 -

Visual issue, hopefully balanced by economic property

www.ntnu.no *Truss Support Structures in OWTs*

4. Preliminary Design

www.ntnu.no *Truss Support Structures in OWTs*

Comparison between 3- and 4- legged truss towers

www.ntnu.no *Truss Support Structures in OWTs*

5. Fatigue Analysis (cooperation work with Stuttgart University)

- Estimation of fatigue loads
 - The wind speed range considered: 4m/s—42m/s by the increment of 2m/s, composed of the phases of power production and idling
 - In each wind, the pair (Hs, Ts) having the highest occurrence probability in one year speed is employed to represent the sea condition in this wind.
 - Six 10-min stochastic realizations in each wind speed. (fixed seed combination for wind and wave)

www.ntnu.no *Truss Support Structures in OWTs*

- Fatigue life estimation
 - Rearrange the load spectra by rain flow counting
 - One-slope S-N curve
 - 3p frequency to determine the equivalent cycles in the serve life(25 years)

www.ntnu.no *Truss Support Structures in OWTs*

6. Ongoing Work

- To optimize the topology of lattice tower and reduce the complex fabrication further.
- Foundation design and comparison of friction and suction piles in OWTs.

Thanks for your attention!

www.ntnu.no *Truss Support Structures in OWTs*

1

Flytende vindturbiner

Modellering- og regulering

Thomas Fuglseth
Ph.D.-student, Inst. for Elkraftteknikk, NTNU

 NTNU

www.ntnu.no

2

Flytende vindkraft – en industri for Norge?

- Norge har mye offshorekompetanse og en sterk energinæring
- Flytende vindkraft er av stor interesse internasjonalt
 - Stort marked i fremtiden
- Norske selskaper allerede inne på utviklingssiden
 - StatoilHydro (tidl. Hydro Energy)
 - Sway





1) Sway AS
2) StatoilHydro

 NTNU

www.ntnu.no

3

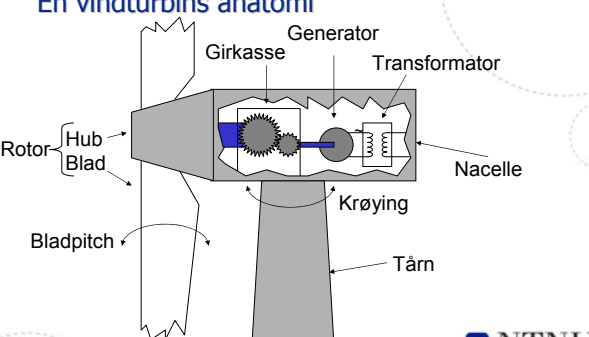
En vindturbins anatomi



 NTNU

www.ntnu.no

4

Krefter på en vindturbin

- To kraftkomponenter på bladet
 - Rotasjonsretning
 - Aksialretning
- Kraft i rotasjonsretningen skaper moment som driver generatoren
 - Gir oss energi
- Kraft i aksialretning bøyer bladene og tårnet
 - Gir oss bare slitasje

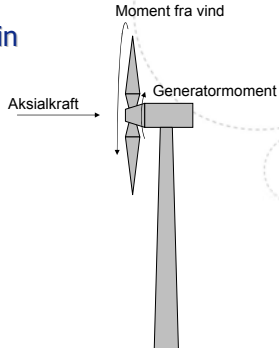

 NTNU

www.ntnu.no

5

Størrelse, masse og mekaniske påkjenninger

- Landbasert turbin: nacellevekten komprimerer tårnet
- Flytende turbin: Nacellevekten bøyer tårnet når konstruksjonen beveger seg
- Krever sterkere tårn, lettere nacelle og/eller fancy regulering

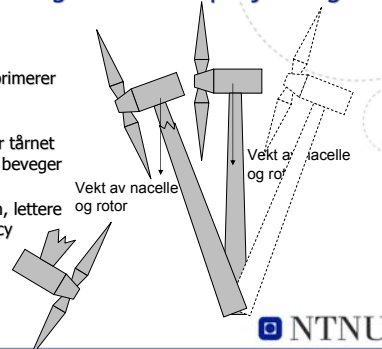

 NTNU

www.ntnu.no

6

Hva kan vi styre?

- Bladpitch
 - Felles
 - Individuell
- Generatormoment og -turtall
 - Kun omformermatede generatorene
 - Dobbelmatet asynkronmaskin ($\pm 30\%$ turtall)
 - Asynkronmaskin med fullomformer
 - Synchronmaskin (viklet eller permanentmagnetisert rotor)

 NTNU

www.ntnu.no

7

Felles bladpitch

- Bestemmer rotormoment
 - Turtall
 - Vindhastighet
- Bestemmer også aksialkraft
- Kan brukes til å dempe ut svingninger i tårn og plattform
 - Reduserer slitasje

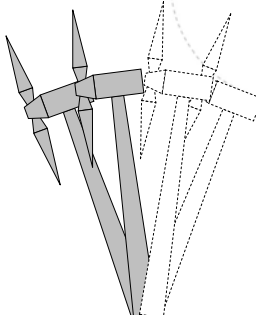

www.ntnu.no

NTNU

8

Individuell bladpitch

- Kan dempe ut vibrasjoner i bladet
 - Varierende vindhastighet over rotordisken
 - 3P-effekten (tårnskygge)
- Kan forlenge levetiden på bladet eller tillate oss å bruke lettere bladkonstruksjon
- Men:
 - Mer slitasje på pitchmekanismen
 - Mer vridningsstress i bladrotten

www.ntnu.no

NTNU

9

Generatormoment og -turtall

- Krever omformerematet generator
- Gir oss mulighet til å ta opp momentvariasjoner fra rotoren
 - Reduserer belastning på aksling og evt. girkasse
 - Kan gå ut over jevn kraftproduksjon
 - Er dette et problem?
 - Store parker jevner ut produksjonen

www.ntnu.no

NTNU

10

Hva driver jeg med?

- Modellere vindturbin og tårn med FAST
 - Freeware fra NREL
- Modellere plattform i WAMIT
 - Frekvensavhengig added mass og potential damping
 - Transferfunksjon fra bølgehode- og frekvens til krefter
- Omforme data i frekvensplanet fra WAMIT til tidsplanmodeller i Simulink
- Koble FAST mot plattformmodell

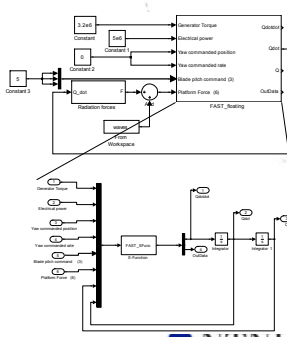

www.ntnu.no

NTNU

11

FAST

- Aeroelastisk vindturbin simulator utviklet ved NREL
- Bevegelsesligningene inkluderer frihetsgrader for flytende fundament
 - Trenger bare en modell for kreftene
- Åpen kildekode
 - Kan modifiseres etter brukerens behov
- Kommer med Simulink-grensesnitt
 - Jeg har modifisert dette til å ta inn hydrodynamiske krefter fra modell i Simulink

www.ntnu.no

NTNU

12

Wamitmodell

- Panelmetode
 - Strukturen deles opp i paneler
 - Trykk-krefter regnes ut ved numerisk integrasjon over alle panelene
- Geometridata generert med Matlab
 - Kan også bruke dedikert 3D-modellerings-programvare
- Wamit gir oss:
 - Frekvensavhengig added mass og potensaldemping
 - Transferfunksjoner for bølgekrefter

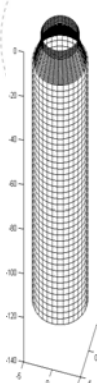

www.ntnu.no

NTNU

13

Fartøydynamikk

$$\mathbf{M} \cdot \ddot{\mathbf{q}} = \sum \mathbf{F}$$

Generalisert treghetsmatrise (masse og treghetsmoment)

$$\mathbf{F}_g + \mathbf{F}_b + \mathbf{F}_{rad} + \mathbf{F}_{wave} + \mathbf{F}_{drag} + \mathbf{F}_{thrust} + \mathbf{F}_{moor} + \mathbf{F}_{wind} + \dots$$

$$\mathbf{q} = \begin{bmatrix} x \\ z \\ \phi \\ \theta \\ \psi \end{bmatrix} = \begin{bmatrix} \text{"surge"} \\ \text{"s surge"} \\ \text{"roll"} \\ \text{"pitch"} \\ \text{"yaw"} \end{bmatrix}$$

NTNU

14

Krefter

NTNU

15

Stivhetskrefter

Vekt

$$\mathbf{F}_g = \mathbf{M} \cdot \mathbf{g}$$

Oppdrift

$$\mathbf{F}_b = \rho \cdot \mathbf{g} \cdot V_{wet}$$

Tetthet av vann (rho) Volum av fortrent vann (V_wet)

V_wet forandrer seg avhengig av posisjon (hovedsakelig hiv, rull og stamp)

$$\mathbf{F}_b = \mathbf{F}_{b0} + \mathbf{C}_b \cdot \mathbf{q}$$

Statisk oppdrift i likevektspunktet Stivhetsmatrise

NTNU

16

Strålingskrefter

Krefter knyttet til at legemet danner bølger når det settes i oscillasjon

$$F_{rad,j} = \sum_{k=1}^6 \alpha_{jk}(\omega) \cdot \ddot{q}_k + \sum_{k=1}^6 \beta_{jk}(\omega) \cdot \dot{q}_k$$

Levetid av bølger i likevektspunktet Levetid av bølger med hastigheten

Adaptiv masse Bistanddemping

$$\sum_{k=1}^6 (m_{jk} + \alpha_{jk}(\omega)) \cdot \ddot{q}_k + \sum_{k=1}^6 \beta_{jk}(\omega) \cdot \dot{q}_k = \sum F_{resten}$$

NTNU

17

Strålingskrefter på tilstandsromform

Bevegelsesligning:

$$\sum_{k=1}^6 (m_{jk} + \alpha_{jk}(\omega)) \cdot \ddot{q}_k + \sum_{k=1}^6 \beta_{jk}(\omega) \cdot \dot{q}_k = \sum F_{resten}$$

Frekvensavhengig added mass og potensialdemping

$$\sum_{k=1}^6 (m_{jk} + a_{jk}) \cdot \ddot{q}_k + \sum_{k=1}^6 b_{jk} \cdot \dot{q}_k$$

Konstant added mass og potensialdemping

$$+ \sum_{k=1}^6 \int_{-\infty}^t K_{jk}(t-\sigma) \cdot q_k(\sigma) d\sigma = \sum F_{resten}$$

Frekvensavhengige termer som konvolusjonsintegral

NTNU

18

Strålingskrefter

- Finn $K_{jk}(\omega)$ fra tabeller over $\alpha_{jk}(\omega)$ og $\beta_{jk}(\omega)$
- Bruk systemidentifikasjonsteknikker til å finne en tilstandsrommodell
 - Subspace-metoder har vist seg å gi best resultat
- For sylindrisk konstruksjon (som Hywind) kan man i stor grad se bort fra frekvensavhengigheten
 - Unntak: K_{11} , K_{22} og K_{33}

$$\dot{\xi}_{jk} = \mathbf{A}_{jk} \xi_{jk} + \mathbf{B}_{jk} \dot{q}_k$$

$$\mu_{jk} = \mathbf{C}_{jk} \xi_{jk} + \mathbf{D}_{jk} \dot{q}_k$$

NTNU

19

Bølgekrefter

Del valgt bølgespektrum inn i diskrete intervaller (~500)

$$\eta_i^2 = 2 \cdot S(\omega_i) \cdot \Delta\omega_i$$

i-ende komponent av bølgeamplitude

Bølgespektrum

Frekvensintervall

Vi antar sinusformede bølger

$$\eta_i(t) = \eta_i \cdot \sin(\omega_i t + k_i x + \varphi_i(t))$$

Romlig forskyving (vanligvis 0)

Tilfeldig fasevinkel

NTNU

20

Bølgekrefter (2)

$$\eta(t) = \sum_i \sqrt{2 \cdot S(\omega_i) \cdot \Delta\omega_i} \cdot \eta_i(t)$$

Bølgeamplitude som funksjon av tid

$$F_{wave}(\omega) = H(\omega) \cdot \eta(\omega)$$

Bølgeinduserte krefter

$$F_{wave}(t) = H(t) * \eta(t)$$

Konvolusjonen kan løses numerisk, enten som et løpende integral i simuleringen eller det kan beregnes i forkant. Den siste metoden gir oss en regenerert tidsserie av bølgekrefter heller enn bølgeamplitude.

NTNU

21

Fortøyning

- Enkel fjærmodell fra StatoilHydro
 - Tilstrekkelig for små utslag ved normale operasjoner
 - Ikke egnet for å modellere mer ekstreme situasjoner
 - Mangler bl.a. demping
 - Mangler ulineariteter som gjør at kreftene blir større ved store utslag

$$F_{moor} = F_{moor,0} + C_{moor} \cdot q$$

Konstant kraft nedover som skyldes vekten av ankerlinene

Kraft som skyldes stramming av ankerlinene når plattformen forskyves fra likevektspunktet

NTNU

22

Plattformmodell

NTNU

23

Vinden

- Er vanligvis bare en plage
 - Vanskelig å modellere
 - Må normalt bare tas hensyn til i design
- For en vindturbin, derimot
 - Velutviklet teori for å modellere vindpåvirkningen
 - Vi har mulighet til å styre vindpåvirkningen
- Eksempel: 5MW turbin ved 10 m/s vind og 12 RPM
 - ca ±20% aksialkraft for 9% moment (og dermed effekt)
 - Krever ±3° bladpitch

NTNU

24

Turbinmodell

- NREL Offshore baseline 5MW
 - Referansemodell laget av NREL for forskningsformål
 - Kan brukes til å sammenligne forskjellige simuleringsverktøy
 - Sammenligne forskjellige plattformmer
 - “Gjennomsnitt” av turbiner fra flere produsenter
 - Repower, Multibrud, Enercon m.fl.

NTNU

25

Generatormodell

- Direktedrevet, PM-generator med fullomformer
 - Variabel hastighet, styrbart moment
 - Høy pålitelighet og regulerbarhet
 - Fleksibel mtp. nettkobling
- Dessverre litt tung
 - Men håp om forbedring

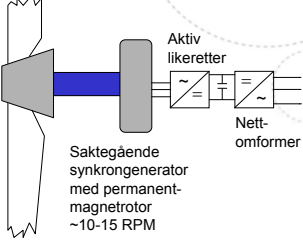

Aktiv likeretter

Nettomformer

Saktegående synkrongenerator med permanentmagnetrotor ~10-15 RPM

NTNU

www.ntnu.no

26

To-akse generatormodell (DQ-modell)

- Modellerer sinusvarierende størrelser som komplekse DC-størrelser
 - Amplitude-fase-representasjon
- Unngår tunge beregninger på sinusstørrelser i tidsplanet
- Per unit-modell
 - Enkel å skalere
- Velegnet til å representere elektriske komponenter i et tregere mekanisk system
- Egner seg ikke så godt til å regne på rask elektrisk dynamikk

NTNU

www.ntnu.no

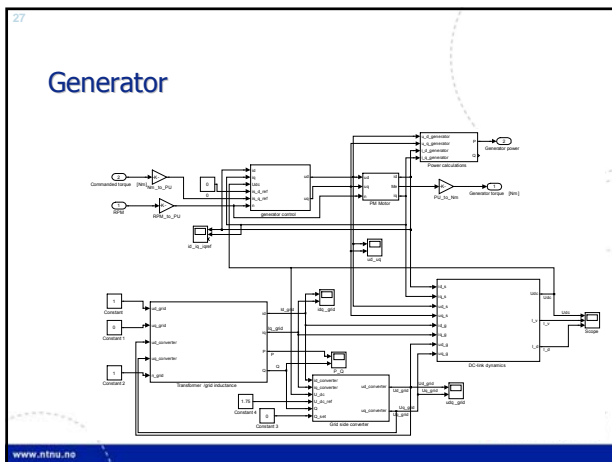

28

Eksempel

- Jagbevegelser
 - Ingen vind, sinusformet bølge
 - 2,5 m bølgehøyde
 - 1,5 rad/s bølgefrekvens/4,2 sek bølgeperiode

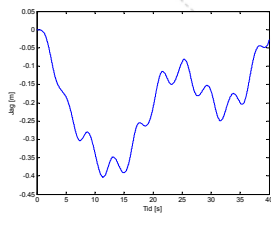

NTNU

www.ntnu.no

29

Eksempel 2

- Ingen bølger
- Vind 7 m/s
- Konstant moment på rotoraksling
 - 1,5 MN
- Mangler fremdeles noen dempingsledd
 - Utslagene blir for store

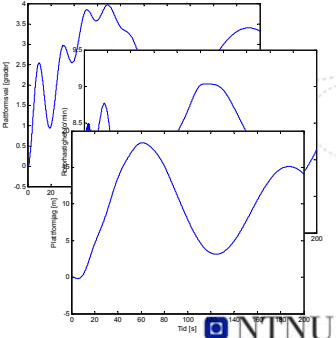

NTNU

www.ntnu.no

30

Regulator design

- Prøve ut mp-QP-basert regulering
 - Baserer seg på sanntidsløsning av et kvadratisk optimaliseringsproblem
 - Kan legge på variable begrensninger
 - Kan designes basert på systemmodell
 - Nært beslektet med Lyapunovteori
 - Egnet til regulering av ulineære systemer
- Er brukt bl.a. i fartøystyring
 - Men ny tankemåte i sammenheng med vindkraft

NTNU

www.ntnu.no

31

"Vanlig" QP-optimalisering

- Minimer en kvadratisk kostfunksjon:

$$V(x) = \min_x \frac{1}{2} x^T Q x + x^T f$$
- Gitt følgende begrensninger:

$$g_i^T x = w_i, \quad i \in \mathcal{E}$$

$$g_i^T x \leq w_i, \quad i \in \mathcal{I}$$

www.ntnu.no 

32

Multiparametrisk QP (mp-QP)

- Kvadratisk problem hvor problemformuleringen og begrensningene forandrer seg som funksjon av et sett med ekstern parametre $u(t)$

$$V(x) = \min_x x^T Q x + x^T F u(t)$$

$$\text{s.t. } Gx \leq W + S u(t)$$

www.ntnu.no 

33

Hvordan kan vi bruke dette?

Hvis vi vil bringe pitchraten til null kan vi velge følgende kostfunksjon:

$$V(\dot{q}) = \min_{\dot{q}} \frac{1}{2} (m_{55} + \alpha_{55}) \cdot \dot{q}_5^2$$

Men da kan vi bli sittende med stasjonært utslag



$$V(q, \dot{q}) = \min_{q, \dot{q}} \left(\frac{1}{2} (m_{55} + \alpha_{55}) \cdot \dot{q}_5^2 + \frac{1}{2} k \cdot q_5^2 \right)$$

Denne vil ideelt sett gi null pitch og pitchrate

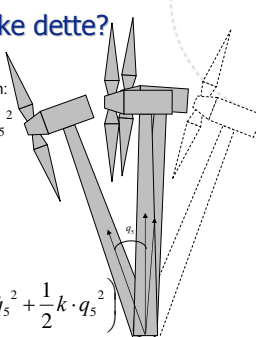

www.ntnu.no 

34

Eksempel

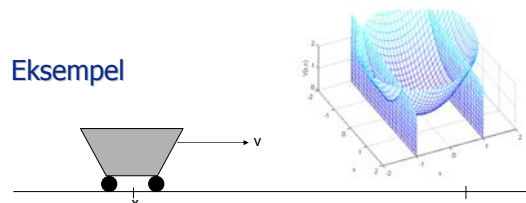

$$V(v, x) = \min_{v, x} \frac{1}{2} M v^2 + \frac{1}{2} Q (x - x_0)^2$$

s.t. $|v| \leq W$

www.ntnu.no 

35

mp-QP i reguleringsystemer

- QP-løser (og LP) egner seg generelt ikke til bruk i sanntidssystemer
 - Ingen hard grense på hvor lang tid det tar å finne en løsning
- Regulering basert på optimalisering og tilstandsestimering har vært brukt i tregere prosesser
- Hva gjør vi?
 - Definer og løs problemet på forhånd
 - Del løsningsrommet opp i et søkbart sett med lineære funksjoner

www.ntnu.no 

36

Hvordan styre?

- Bruk kjent fartøystyringsteori, og tenk på rotoren og generatoren som en thruster
- Oppslagstabell over tilgjengelig aksialkraft og moment for en gitt vindhastighet og turtall
- Finn den kombinasjonen av turtall og bladpitch som gir ønsket aksialkraft og samtidig mest mulig energi
 - Her må man selvsagt ta hensyn til treghet i systemet
 - Det er for eksempel ønskelig å legge inn optimalitetskriterier som begrenser endring i turtall og moment slik at dette ikke skjer for raskt

www.ntnu.no 

37

Kostnadsfunksjon

- Minimer en kvadratisk funksjon av følgende variable:
 - Plattformpitch
 - Bladutslag (flapwise og edgewise)
 - Forskjell mellom målt og ønsket moment
 - Forskjell mellom målt og ønsket fart
 - Vridning i aksling/girkasse

www.ntnu.no 

38

Begrensninger

- Harde begrensninger:
 - Maksimal rotasjons hastighet
 - Grenser for bladpitch
 - Maksimalt generatormoment
 - Maksimal mekanisk og elektrisk effekt
- Variable begrensninger:
 - Kommandert effekt (basert på målt vindhastighet)

www.ntnu.no 

39

Avsluttende kommentarer

- Flytende offshore vindkraft har stort potensiale
 - Leverer mer energi enn tilsvarende turbiner på land
 - Unngår politiske problemer med vindkraft på land
- Krever nytenkning i forhold til eksisterende vindkraftteknologi for å bli lønnsom
 - Estetikk og støyeegenskaper kan ofres for å gi bedre robusthet og økonomi
 - Regulering for levetid heller enn jevn produksjon
- Nytt bruksområde for norsk offshorekompetanse
- Nytt marked, vi kan være med fra starten

www.ntnu.no 

40

Spørsmål?



www.ntnu.no 

Korrosjonsbeskyttelse av offshore vindturbiner

Ole Øystein Knudsen
SINTEF Materialer og Kjemi

SINTEF

Materialer og kjemi

1

Innhold

- Behov for korrosjonsbeskyttelse
- Hvilke krav skal vi stille til korrosjonsbeskyttelse?
- Erfaringer fra andre bransjer
- Hvilke utfordringer har vi?
- Ny teknologi

SINTEF

Materialer og kjemi

2

Behov for korrosjonsbeskyttelse

Ulike behov og ulike utfordringer på forskjellige deler av konstruksjonen

Mekanisk og elektrisk utstyr

Nacelle

Bærende konstruksjon og forankring

Atmosfærisk sone

Plaskesone
Undervannssone



SINTEF

Ma

Hvilke krav skal vi stille til korrosjonsbeskyttelse?

- Overordnede krav til sikkerhet og produksjonsregularitet
- Lavest mulig levetidskostnad
- Noen kjensgjøringer:
 - Å vedlikeholde maling på feltet koster 10 x mer enn å male nybygg på verft
 - Vedlikeholdsbelegg har dårligere kvalitet enn det originale belegget
 - Vanskelig tilkomst
 - Korrosjonshastighet i marint miljø ~1 mm/år
- KONKLUSJON:
 - Mest mulig vedlikeholdsfritt

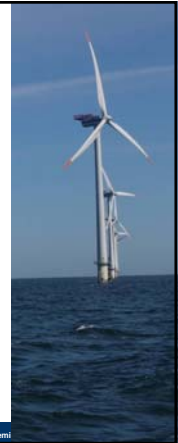

SINTEF

Materialer og kjemi

Erfaringer fra andre bransjer: Offshore olje og gass produksjon

- Atmosfærisk sone:
 - Vedlikehold av konvensjonelle 3-strøk malingsystemer må starte etter < 10 år
 - Termisk sprøytet metallbelegg kan gi svært lang levetid
- Plaskesone:
 - Gode erfaringer med gummiering
- Under vann:
 - Belegg + katodisk beskyttelse er uproblematisk



SINTEF

Erfaringer fra andre bransjer: Vegdirektoratet



- Termisk sprøytet sink + korrosjonsbeskyttende malingsbelegg
- Rombaksbrua utenfor Narvik: 40 år uten vedlikehold – ingen korrosjon

SINTEF

Materialer og kjemi

4

Hvilke utfordringer har vi?

- Bevegelige deler:
 - Kombinasjon av slitasje og korrosjon gir hurtig materialtap
- Bærende konstruksjon - atmosfærisk sone
 - Vedlikeholdsfrie belegg med levetid > 20 år
 - Til en akseptabel pris
- Bærende konstruksjon – plaskesone
 - Vedlikeholdsfrie belegg med levetid > 20 år
 - Til en akseptabel pris

Ny teknologi

- Beskyttelse mot kombinert slitasje og korrosjon i bevegelige deler
- Korrosjonsbeskyttende malingsbelegg

Selvreparerende belegg

- Mikrokapsler i belegget som frigjør et reparasjonsmiddel når de brytes
- Reparasjonsmidlet tetter belegget og gjenoppretter korrosjonsbeskyttelsen

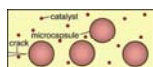

Fig 1: Cracks formed in the matrix



Fig 2: Release of the healing agent

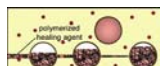
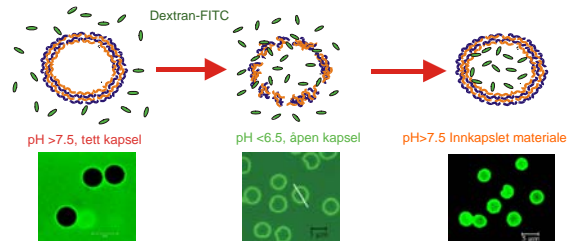

Fig 3: Polymerization

Smarte belegg

- Nanokapsler i belegget som frigjør kjemikalier (for eks. Korrosjons inhibitorer) under eksterne stimulus som for eks. pH, saltkonsentrasjon eller temperatur



Selvsmedende belegg

- Smøremidlet ligger i kapsler i belegget og frigjøres etter hvert som slitasjen blottleder det

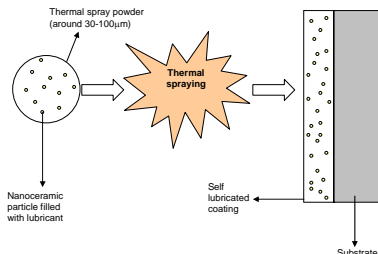

Smarte belegg

- Leirebaserte materialer i belegget som fanger opp korrosive ioner og frigjør korrosjons inhibitorer

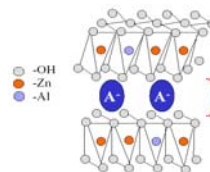

"Nanofeller", som for eks. Zn-Al lagdelt dobbel hydroksid (LDH) pulver

Takk for oppmerksomheten

Optimalisering av berekonstruksjon for flytande vindturbin

Idé og eksempel

Ivar Fylling
MARINTEK

Trondheim 22.01.2009

KMB Project – Design analysis tools: Wind turbine implemented in SIMO

Results closely corresponding with 'standard' tools. First test comparison, uniform wind:

Wind speed	8 m/s		
Rotor diameter	126 m		
Wind power, rotor area	3990 kW		

Parameter	FAST- Flex 5	SIMO	Ratio	
Rotation speed	rpm	9.00	9.34	1.04
Torque	kNm	2120	1913	0.90
Thrust	kN	385	389.0	1.00
Rotor Power	kW	1883	1872.0	0.99

Pitch- and torque control under implementation

SIMO application: All aspects obtainable from rigid-body model; Motions, mooring loads, etc.

The same wind load model to be implemented in FEM analysis in RIFLEX to comprise both rigid-body and elastic deformations

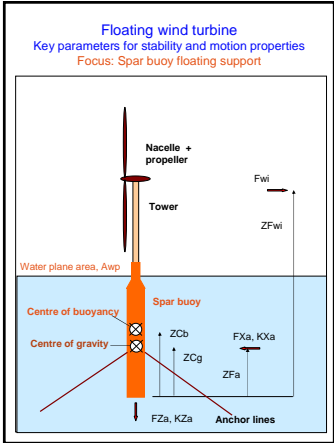

Idea:
Conceptual design tool for floating wind turbine support structures

Objective

Provide efficient design tools for minimum cost design of floating support structures, including mooring system and cable connection.

Development and research tasks

- Establish tentative design criteria, with respect to stability, extreme loads, fatigue loads, and functional requirements.
- Parameterization of support structure and identification of relevant cost models.
- Adaption and development of relevant response analysis programs, covering wind- wave- and current loading. Tentatively this should be done as a frequency domain analysis, for forces, rigid-body motions, and tower bending moment (elastic response).
- Combining the 3 above items with state-of-art optimization code in order to facilitate a minimum cost design of the support structure.

Background experience: **MOOROPT**

Simultaneous optimisation of deepwater mooring- and riser system using

- Shellware response analysis programs
- Shellware optimization code.

Problem formulation

3 Key items for optimisation

- Objective function**
Cost function to be minimised:
Support structure cost, operation and maintenance cost.
- Constraints**
Design requirements: Support capacity, stability, motion characteristics, offset limitation, service life, ...
- Variables**
Design parameters influencing the objective function and/or constraint related responses: Column diameter, draught, ballast, ...

Simple demonstration example in EXCEL

- Conceptual specification of spar buoy support structure
- Static equilibrium and stability
- Natural heave and pitch period checking
- Primitive cost model
- Optimising column diameter and draught to give a minimum cost design

Simple example – static analysis of spar buoy support structure.

1. Objective function

$$F = F_{Steel} + F_{Ballast}$$

F_{Steel} Cost of spar buoy materials

$F_{Ballast}$ Cost of heavy ballast material

2 Constraints

1. Vertical equilibrium at specified draught
2. Pitch period longer than 20 s
3. Pitch period shorter than 0.8 * heave period
4. Maximum pitch (static) not larger than for initial system

3 Free variables

- Spar diameter (>8 m)
- Spar draft (>70 m, <130 m)
- Fixed ballast mass
- Water ballast mass

Fixed parameters

- Nacelle mass
- Tower mass

Før optimalisering

Variables	Variant	Basis
Nacelle mass	240.00	240.00
Tower mass	249.00	249.00
Spar diam.	9.40	9.40
Spar draft	120.00	120.00
Fixed ballast	3900.00	3900.00
Water ballast	215.35	75.89
Heave period	31.01	31.01
Pitch Period	28.62	28.62
Pitch angle, deg	2.73	2.73
Cost	Variant/Basis	1.00

Etter optimalisering

Variables	Variant	Basis
Nacelle mass	240.00	240.00
Tower mass	249.00	249.00
Spar diam.	14.58	9.40
Spar draft	70.00	120.00
Fixed ballast	5585.69	3900.00
Water ballast	2523.88	75.89
Heave period	36.94	31.01
Pitch Period	20.47	28.62
Pitch angle, deg	2.73	2.73
Cost	Variant/Basis	0.61

Mass and cost, 'basis' and 'variant', 240 t nacelle, 249 t tower.

	Variant	Basis	NOK/t
Steel, t	2429	3500	12000
Fixed ball, t	5584	3900	2000
Cost, MNOK	40	50	

Model for column steel mass (example)

ExpH	2
ExpD	2
Spar steel mass =	
$M_{basis}(Hvar/Hbasis)^{ExpH}(Dvar/Dbasis)^{ExpD}$	

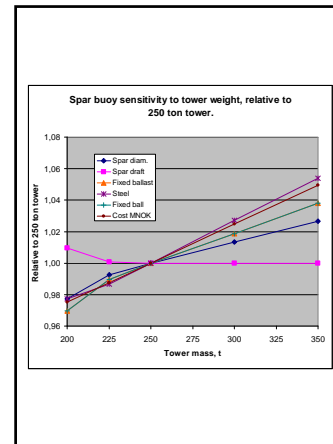
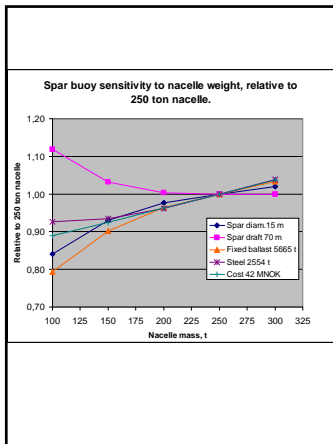

- The floating support structure and anchoring system will constitute a substantial part of the cost of a floating wind turbine
 - To obtain a minimum cost design with satisfactory stability and motion behaviour is a challenge
- This presentation does not show *the* answer
- It points to a possibility and describes a method
 - It demonstrates a simple tool for conceptual floating support optimisation

Nettintegrasjon

Kontrollmetoder for variabel hastighet turbiner, Jarle Eek, PhD student NTNU

Centralized control of wind farms, Bing Liu, Phd student NTNU

Multi-terminal HVDC for offshore wind farms, Temesgen M Haileselassie, PhD student NTNU

Vindkraft til offshore olje og gass installasjoner, Magnus Korpås, Forsker SINTEF Energiforskning

Offshore vind i Europa – TradeWind, Kjetil Uhlen, Seniorforsker, SINTEF Energiforskning

System impacts of large scale wind farms, Tobias Aigner, PhD student NTNU

Planer for offshore transmisjonsnett, Kjartan Hauglum, Statnett

Optimalt design av offshore transmisjonsnett, T Trötscher, Trainee, Statnett/SINTEF/BKK

HVAC tilkobling av offshore vindparker, Georg Balog, Nexans

Lillgrund vindpark, Jan Norling, Vattenfall

Reguleringsmetoder for variabel-hastighet vind-turbiner – innflytelse på stabilitet

Presentasjon Vind FoU, Trondheim - 22. Januar 2009

Janle Eek



NTNU Norwegian University of Science and Technology - Department of Electrical Power Engineering - Electrical Power Systems Group

Motivasjon for variabel hastighet

- Økt regulerbarhet.
 - Lavere belastning på mekaniske komponenter
 - Bedre utnyttelse av energien i vinden. (optimal regulering) spesielt i lav-vind området.
 - Støy
- Stabilitetsegenskaper.
 - Svakere kobling mellom hastighet og moment/(effekt) gjør generatorene stabile ved forstyrrelser.
 - Regulering av aktiv og reaktiv effekt.

NTNU Norwegian University of Science and Technology - Department of Electrical Power Engineering - Electrical Power Systems Group

Innvirkning av vind på turbinkonstruksjon

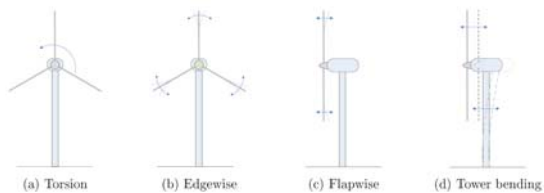

Source: Bianchi et. al.

NTNU Norwegian University of Science and Technology - Department of Electrical Power Engineering - Electrical Power Systems Group

Effekt- og skyvkraft-karakteristikker

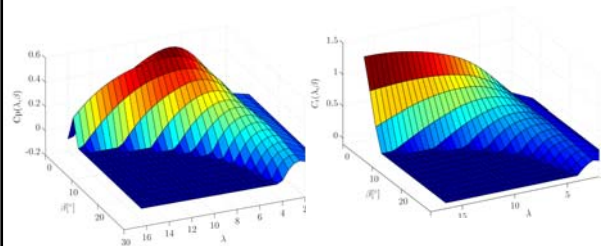

Source: ECN

NTNU Norwegian University of Science and Technology - Department of Electrical Power Engineering - Electrical Power Systems Group

Effekt og moment i dellast

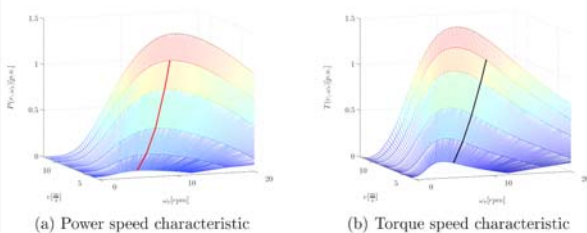

NTNU Norwegian University of Science and Technology - Department of Electrical Power Engineering - Electrical Power Systems Group

Effekt og moment i fullast

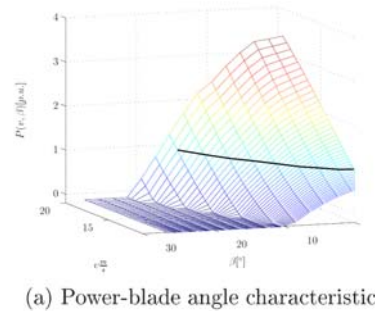

NTNU Norwegian University of Science and Technology - Department of Electrical Power Engineering - Electrical Power Systems Group

Hastighetsområde for vindturbin

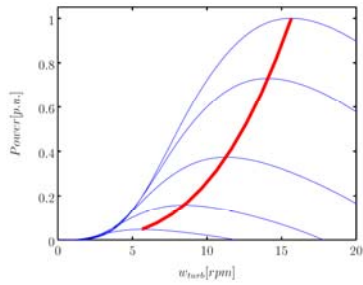
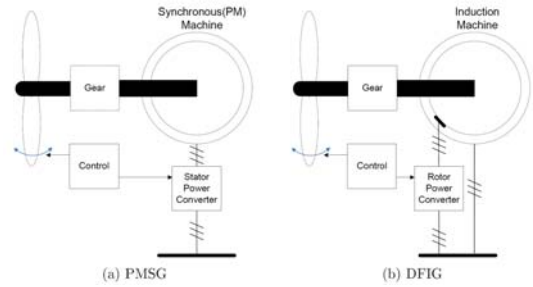

Figure 5.3: The speed range of analysed turbine

Generatorer



(a) PMSG

(b) DFIG

Luftgapsmoment

Rotor flux-orientert PMSG (rund rotor):

$$t_{el} = \psi_{sd} i_{sq} - \psi_{sq} i_{sd}$$

Stator flux-orientert (-nett flux orientert)
DFIG(rund rotor):

$$t_{el} = \frac{l_r}{l_s} (\psi_{sd} i_{rq} - \psi_{sq} i_{rd})$$

Generalisert fullast regulering (pitch)

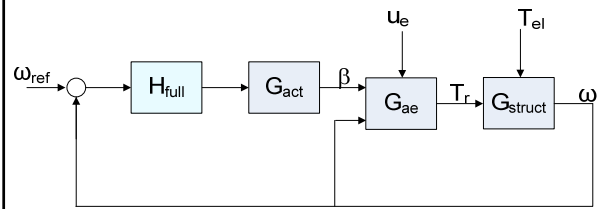

Generalisert reaktiv effekt regulering

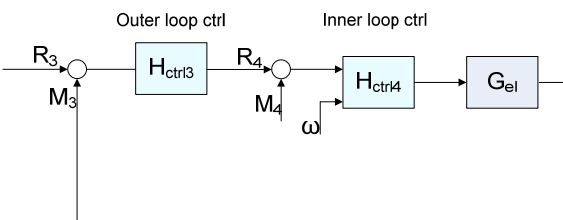

Generalisert delast regulering (generator)

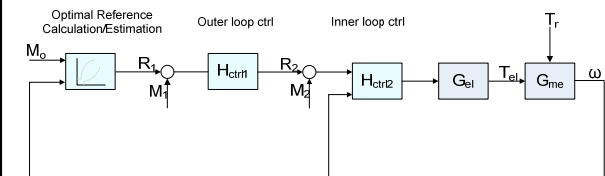

Eigenverdiplot for konstant momentregulering uten tilbakekobling av hastighet ved $u_e = 10$ m/s
Innvirkning av torsjonssvingninger

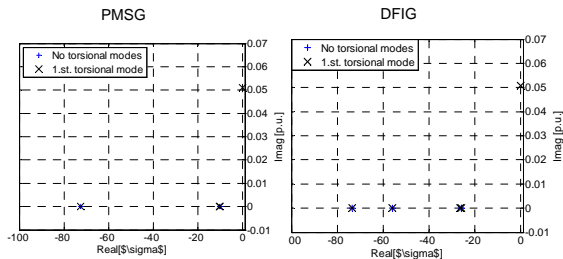

NTNU Norwegian University of Science and Technology - Department of Electrical Power Engineering - Electrical Power Systems Group

Eigenverdiplot for konstant momentregulering uten tilbakekobling av hastighet ved $u_e = 10$ m/s
Innvirkning av "flapvis" (flapwise)

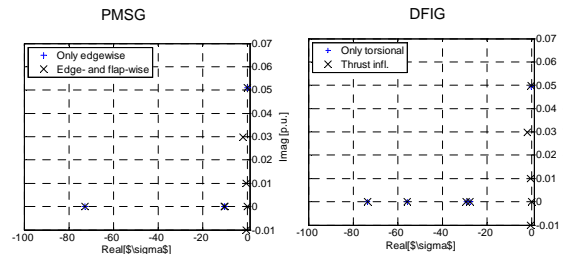

NTNU Norwegian University of Science and Technology - Department of Electrical Power Engineering - Electrical Power Systems Group

Eigenverdiplot for konstant momentregulering med tilbakekobling av hastighet ved $u_e = 10$ m/s

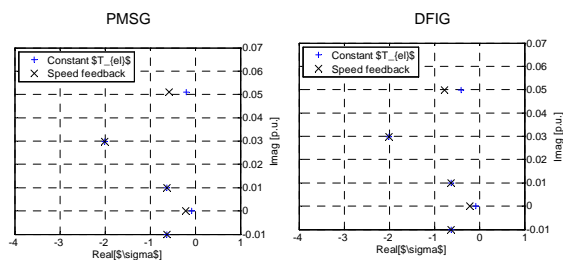

NTNU Norwegian University of Science and Technology - Department of Electrical Power Engineering - Electrical Power Systems Group

Eigenverdiplot effektregulering (tilbakekoblet) hastighet ved $u_e = 10$ m/s

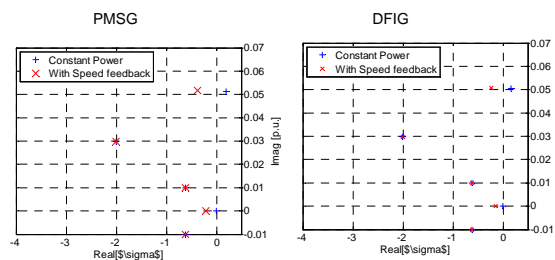

NTNU Norwegian University of Science and Technology - Department of Electrical Power Engineering - Electrical Power Systems Group

Dempning av torsjonssvingninger

Generelt er svingninger i hovedakslingen ønsket p.g.a. slitasje av bl.a. gir.
(Gir-problemer i vindmøller er velkjent.)

To metoder for dempning:

1. Klassisk dempetiltsats. (som for synkronmaskiner.)
2. Regulering av generatorens hastighet.

NTNU Norwegian University of Science and Technology - Department of Electrical Power Engineering - Electrical Power Systems Group

Regulering av generatorens hastighet $u_e = 10$ m/s

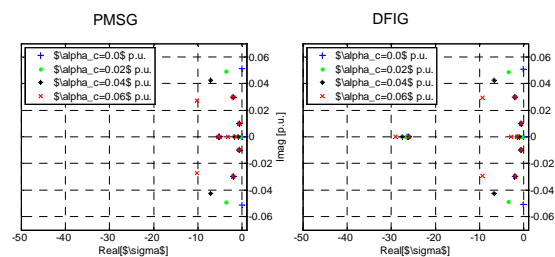

NTNU Norwegian University of Science and Technology - Department of Electrical Power Engineering - Electrical Power Systems Group

Dempetilsats

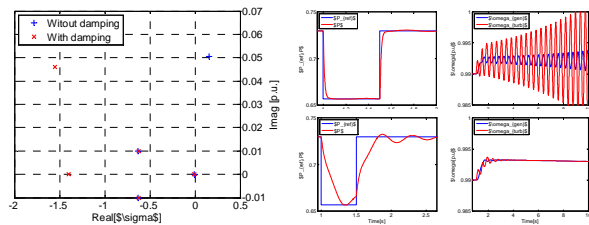

NTNU Norwegian University of Science and Technology - Department of Electrical Power Engineering - Electrical Power Systems Group

Vindpark i kraftsystemet Innvirkning av dempetilsats

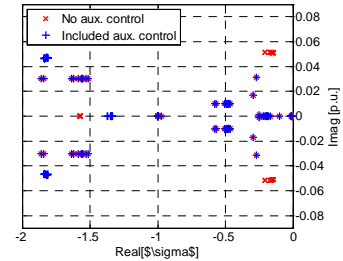

NTNU Norwegian University of Science and Technology - Department of Electrical Power Engineering - Electrical Power Systems Group

Oppsummering/Konklusjoner

1. PMSG og DFIG er sammenlignet for samme vindturbin. Det er anvendt samme reguleringsløyfer for begge generatorer.
2. Turbinmodellen har en representasjon av vindens skyvkraft og momentutviklingen gjennom bladenes løft.
3. Skyvkraften påvirker svingninger i tårn og blader, og koblingen til vindmøllens moment er studert for å avdekke mulig vekselvirkning med komponenter i nettet.
4. Koblingen til momentet er svak og regulering av det elektriske momentet har liten innvirkning på svingemodi koblet til tårn og blader.
5. Turbinen har dårlige dempede torsjonssvingninger
6. Det er vist hvordan torsjonssvingninger ikke er relatert til generatortype, men hvilken metode som er anvendt for regulering av det elektriske moment.
7. Spesielt vil regulering av konstant effekt (typisk fullast) være destabiliserende og i verste fall gjøre turbinen ustabil.
8. Generelt er tilbakekobling av generatorhastighet stabiliserende.
9. Torsjonssvingninger kan dempes med en klassisk dempetilsats eller ved direkte regulering av turbinens generatorhastighet.

NTNU Norwegian University of Science and Technology - Department of Electrical Power Engineering - Electrical Power Systems Group

Centralized control of wind farm

Bing Liu
PhD Candidate
Department of Electric Power Engineering, NTNU

Challenge of wind power integration – Active power response

- **Frequency Droop** – React to Grid Frequency Variation
- **Power Ramp Rate Control** – Limits the Power Change Speed due to Wind Speed Variation
- **Startup and Shutdown Sequence**

NTNU
Det skapende universitet

Challenge of wind power integration – Reactive power response

- **Fault Ride Through**
- **Voltage Droop** – React to grid voltage variation
- **Co-ordination** whole wind farm electrical system – Capacitor Bank / Transformer type changer

NTNU
Det skapende universitet

Why do wind farm modeling?

- Optimize wind farm control strategy & confirm wind farm performance
 - Dynamic performance during the faults
 - Investigate network losses
- Identify requirements for grid interconnection
 - Analyse network stability
 - Analyse network reinforcements

NTNU
Det skapende universitet

Wind Turbine Model

NTNU
Det skapende universitet

Blades Model

NTNU
Det skapende universitet

7 Drivetrain model - done in Fortran

$$T_a - T_{wtr} = J_{wtr} \dot{\Omega}_{wtr}$$

$$T_{gen} - T_{em} = J_{gen} \dot{\Omega}_{gen}$$

$$T_{wtr} = K_{sw} \left[(\Omega_{wtr} - \frac{\Omega_{wtr}}{N}) dt + D_s (\Omega_{wtr} - \frac{\Omega_{wtr}}{N}) \right]$$

Symbols	Notes	Symbols	Notes
P_{wtr}	Mechanic power extracted	T_{em}	Generator electronic magnetic torque
A_{wtr}	Wind turbine Rotor area	T_{gen}	Generator torque
ρ	Air density	T_{wtr}	Wind turbine shift torque
cp	Power Coefficient	T_a	Aerodynamic torque
λ	Tip speed ratio	J_{gen}	Generator moment of inertia
θ	Pitch angle in degrees	J_{wtr}	Wind turbine moment of inertia
R	Rotor radius	K_{sw}	Equivalent turbine shaft stiffness
V_w	Wind speed	N	Gearbox Ratio
Ω_{wtr}	Generator mechanic speed	D_s	Equivalent turbine shaft damping
Ω_{gen}	Turbine mechanical speed	D_{gen}	Generator damping constant

www.ntnu.no

8 Back to back converter

Manitoba HVDC Research Centre

NTNU Det skapende universitet

www.ntnu.no

9 Performance during gust

www.ntnu.no

10 Reactive power response during voltage drop 650ms

Det skapende universitet

www.ntnu.no

11 Harmonics analysis

NTNU Det skapende universitet

www.ntnu.no

12 Centralized wind farm controller

frequency control for isolated grid with energy storage

NTNU Det skapende universitet

www.ntnu.no

13

Thanks!

Takk!

感謝!

 NTNU
Det skapende universitet

www.ntnu.no

14

Project Background

PHD Topic: Grid connection of deep sea wind farms	
Funding	RSO grant from NTNU with one-year teaching duty
Duration	April 2008 -- 31 st March 2012
Supervisors	Tore Undeland / Kjetil Uhlen (SINTEF) (Co.)
Hosted Institute	Department of Electric Power Engineering, NTNU
Goal No.1	Solutions & system for connecting offshore wind
Goal No.2	Wind farm level control to support grid
Goal No.3	Power system security analysis

 NTNU
Det skapende universitet

www.ntnu.no

NTNU

Multiterminal HVDC for Offshore Windfarms

By: Temesgen Haileclassie
PhD. Student
Department of Electric Power Engineering
NTNU

1 Vindkraft FoU Seminar, 23 Jan 09

NTNU

Multiterminal HVDC as a potential solution-Why?

1. Proposed wind farms as far as 100-300km away from shore in the North sea
→HVAC is less attractive for far offshore sites
2. Trends to electrify oil/gas platforms from shore (Troll A, Valhall)
→ HVDC has been in use

- Multi-terminal HVDC (MTDC) suggested as a potential solution for integration of offshore wind farms, and oil/gas platforms
- Other alternatives being HVAC, and point-to-point HVDC

2 Vindkraft FoU Seminar, 23 Jan 09

NTNU

A hypothetical scenario of offshore Multiterminal HVDC System



3 Vindkraft FoU Seminar, 23 Jan 09

NTNU

Advantages of MTDC for Offshore systems

- Minimized transmission loss
- Increased availability of the network
- Decreased number of converter units
– hence less costly than point-to-point HVDC
- Easy connection of a new offshore load/generation terminal

4 Vindkraft FoU Seminar, 23 Jan 09

NTNU

Converter types for use in MTDC

1. Classical (Thyristor based) HVDC

- Consumes uncontrollable reactive power
- Not capable of black start

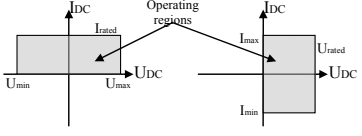

U-I curve for classical HVDC U-I curve for VSC-HVDC

2. Voltage Source Converter (VSC-HVDC)

- Independent control of active and reactive power
- Capable of black start, capable of reactive power support
- Many suitable features for multiterminal operation

5 Vindkraft FoU Seminar, 23 Jan 09

NTNU

Currently Operational MTDC's in the World

1. **Hydro Quebec** – New England transmission line in Canada (1986,1992), with classical HVDC
 - ✓ A three terminal connection
 - ✓ Ratings: 2000MW each, ±450 KV DC
2. **Italy-Corsica-Sardinia** (1965,1992), with classical HVDC, 3 terminal
 - ✓ Rating 200MW, 300MW, ±200 KV DC
3. **Shin-Shinano** Substation of Tokyo Electric Power Company (1999)
 - ✓ 3 back to back connected VSCs terminals
 - ✓ Rating: 53MVA each, ±10,6 KV DC

6 Vindkraft FoU Seminar, 23 Jan 09

Shin-Shinano -3 terminal HVDC connection

Vindkraft FoU Seminar, 23 Jan 09

Main Challenges with Development of Multiterminal HVDC

- Need for faster fault detection and protection systems
- Technological challenges with DC circuit breakers
 - Currently the role of DC circuit breakers is played by control and protection system involving the AC side breakers

Vindkraft FoU Seminar, 23 Jan 09

Simulation study for VSC-MTDC

Vindkraft FoU Seminar, 23 Jan 09

Active and reactive power control (for stiff grid)

-Step response from no load to full rating time of 150ms

-Very fast!

Vindkraft FoU Seminar, 23 Jan 09

DC bus voltage control

Figure: DC bus voltage

- Controls DC capacitor's charging current thereby controlling the DC voltage
- Step response of 100ms observed

Vindkraft FoU Seminar, 23 Jan 09

AC voltage control for weak grid connection

AC voltage in weak grid changes with changing load levels

AC voltage control by reactive power compensation

No steady state error in AC voltage!

Vindkraft FoU Seminar, 23 Jan 09

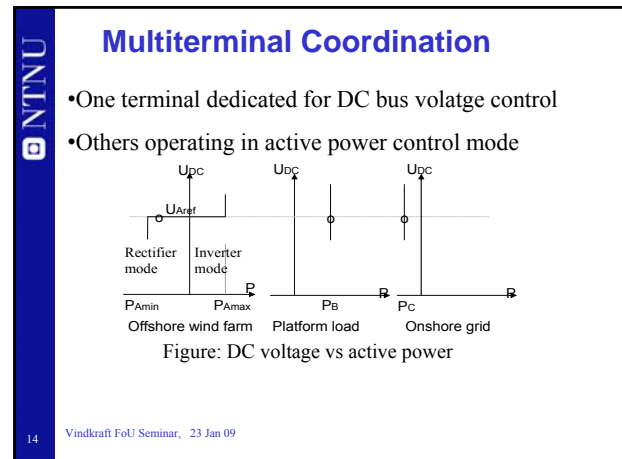
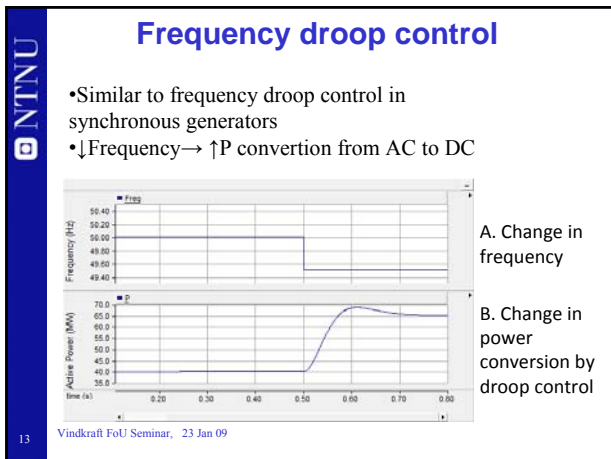

Thank you.

Questions?

15 Vindkraft FoU Seminar, 23 Jan 09

Vindkraft til offshore olje- og gassinstallasjoner

Magnus Korpås, Leif Warland
SINTEF Energiforskning

Vindkraft til offshore olje- og gassinstallasjoner

- Motivasjon og utfordringer
- Case studie: Samdrift vindkraft og 2x20 MW gassturbin
- Reduksjon av brenselforbruk og utslipp til luft
- Kostnadsreduksjoner

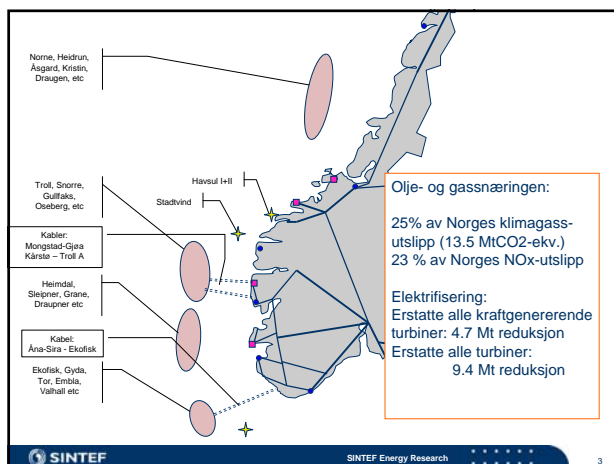

Vind til oljeplattform: Autonome systemer

- Redusert brenselforbruk, CO₂-utslipp og NO_x-utslipp
 - Eks: Samdrift vindkraft og 2x20 MW gassturbin
 - Høye kostnader knyttet til utslipp og reduserte inntekter knyttet til gassforbruk → tidlig marked for vindkraft på dypt vann
- Lavere kabelkostnader jmf. nettilknytning land
- Stabilitet
- Elkvalitet
- Driftsikkerhet (N-1)

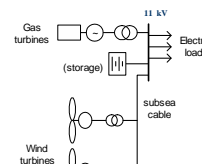

Vind til oljeplattform: Nettilknytning

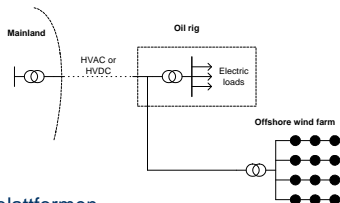

- Kabeltilkobling for oljeplattformen
 - Gassturbinene ikke i drift (nøddaggregat)
 - Flere elektriske motordrifter
- Vindkraft dekker deler av lasten og overskudd eksporters
 - Eksempel: Beatrice Demonstrator project (2x5MW vind dekker 30 % av last)
 - Ulike tilkoblingsalternativer finnes

Case studie : Generelt eksempel

- Konstant last 25 MW over hele året
- Base case: 2 gassturbiner (20 MW maks) deler lasten likt
- Simulering av 0 til 5 vindturbiner à 5 MW
- Mål:
 - Hvor mye vil vindkraften redusere årlig brenselforbruk og utslipp til luft (CO₂ og NO_x)?
 - Kostnadsreduksjoner

Driftsstrategi gassturbiner

- **Strategi 1**
 - 2 gassturbiner deler lasten likt og slåes aldri av
- **Strategi 2**
 - En gassturbin er alltid på, og den andre slåes av dersom vind- og lastsituasjonen tillater det
 - hensyntatt oppstartstid for gassturbin margin for vindvariasjoner

Virkningsgrad og brenselforbruk

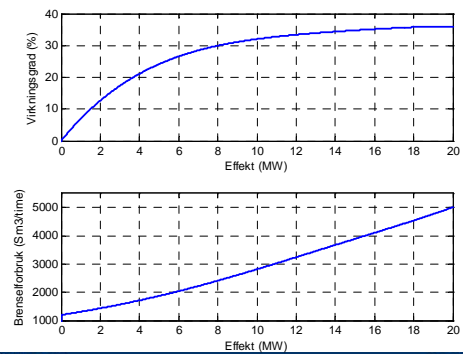

CO₂- og NO_x-utslipp vs. effekt

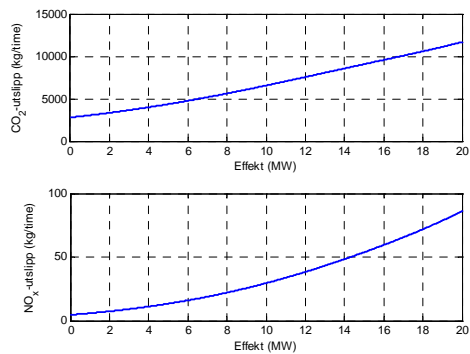

Produksjon fra vind

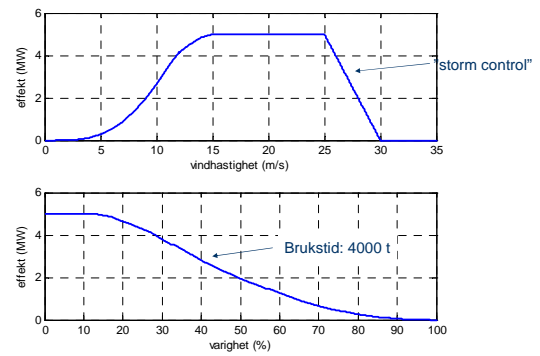

Produksjon fra hver gassturbin Strategi 1

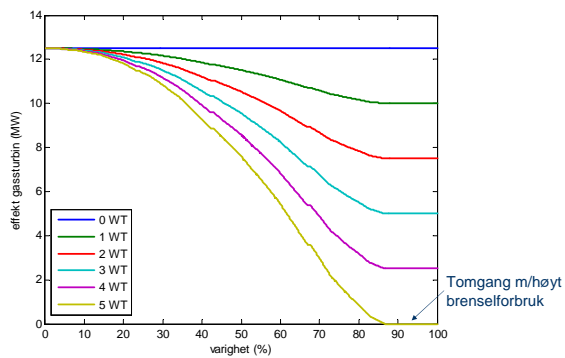

Produksjon fra hver gassturbin Strategi 2

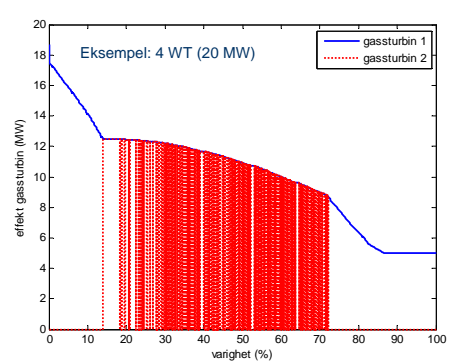

Redusert brenselforbruk vs. vindkraft

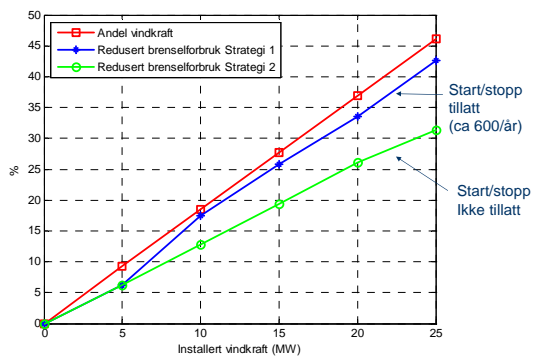

SINTEF

SINTEF Energy Research

13

Brensel- og utslippsreduksjoner

Installert vind	25 MW
Forbruk	219 GWh/år
Produksjon vind	101 GWh/år
Andel vind av energiforbruk	46 %
Brensel-reduksjon	26 Mill Sm ³ /år
CO ₂ -reduksjon	62 1000 tonn/år
NO _x -reduksjon	353 tonn/år
Brensel-reduksjon	0.26 Sm³/kWh vind
CO₂-reduksjon	0.6 kg/kWh vind
NO_x-reduksjon	3.5 gram/kWh vind

SINTEF

SINTEF Energy Research

14

Konstandsreduksjon pr MWh vind

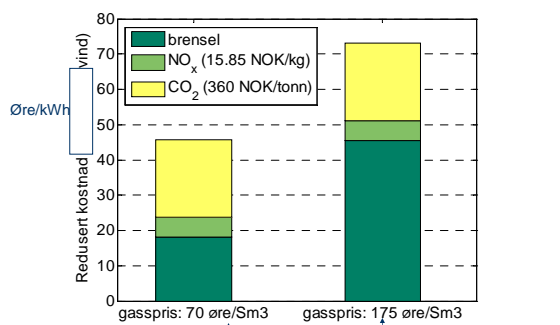

"kraft fra land til sokkelen" 2002

Nasj. budsjettet 2009

SINTEF

SINTEF Energy Research

15

Oppsummering



- Olje- og gassinstallasjoner er et gunstig tidlig marked for offshore vindkraft på dypt hav
- Ulike tilkoblingsmuligheter (autonomt og landkabel)
- Optimal samdrift gass- og vindkraft er viktig for å oppnå høy virkningsgrad og lav slitasje på gassturbiner
- Potensialet for kostnadsreduksjon knyttet til redusert
 - gassforbruk
 - CO₂-utslipp
 - NO_x-utslipp
- ...er betydelig og i størrelsesorden 75 øre/kWh for en gasspris på 1.75 NOK/Sm³ og dagens avgifter på utslipp.

SINTEF

SINTEF Energy Research

16



Integrasjon av onshore og offshore vindkraft i Europa

Kjetil Uhlen (med god hjelp av)
Leif Warland, Magnus Korpås og John O. G. Tande,
SINTEF Energy Research

•Project under EU-programmet "Intelligent Energy Europe" (2006-2009)
•Coordinator: European Wind Energy Association (EWEA)

Intelligent Energy Europe



Outline

- TradeWind - Objectives and scope
- Market and network modelling
- Analysis of increasing transmission capacity
 - New connections analysed
 - Sensitivities and bottleneck costs
 - Offshore grid scenarios
- Conclusions and recommendations



Outline

- TradeWind - Objectives and scope
- Market and network modelling
- Analysis of increasing transmission capacity
 - New connections analysed
 - Sensitivities and bottleneck costs
 - Offshore grid scenarios
- Conclusions and recommendations



Objectives

- **Long-term Objective:** To facilitate the dismantling of barriers to the large-scale integration of wind in European power systems, on transnational and European levels,
- **Specific objectives:** To formulate recommendations for
 - policy development,
 - market rules,
 - and interconnector allocation methods to remove barriers to wind power integration.
- The analysis includes the transmission networks in the synchronous zones of UCTE, Nordel, GB and Ireland.
- **Aim:** support various (EU and national) processes in reaching political targets for renewable energy developments



Scope and vision

- TradeWind visions a single European grid and power market system.
- The scope of the project is to explore:
 - To what extent large scale wind power integration could benefit from reinforcements of the interconnections between the member states in Europe.
 - What are the conditions for sound power market design to ensure a cost effective integration of wind power at EU level.



Project organisation

Phase 1 Preparation			
	WP2 (GH) Wind power scenarios	WP3 (Sintef) Grid modelling and power system data	WP4 (Riso DTU) Identification of market rules
Phase 2 Simulation and analysis			
	WP5 (VTT) Continental power flows	WP6 (Sintef) Grid scenario's	WP7 (3E) Analysis of market rules
Phase 3 Recommendations			
	WP8 (EWEA) Recommendations for grid upgrade, market organisation and policy development		

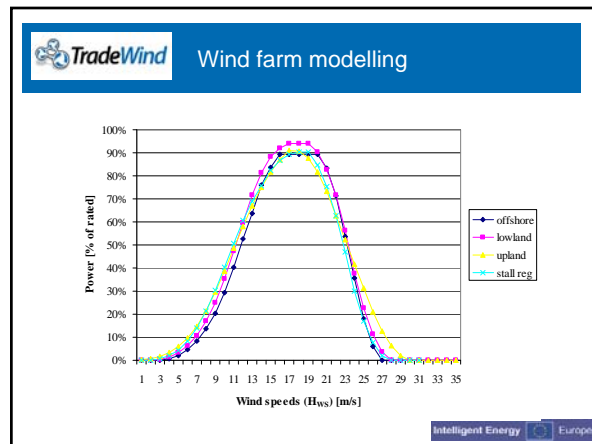
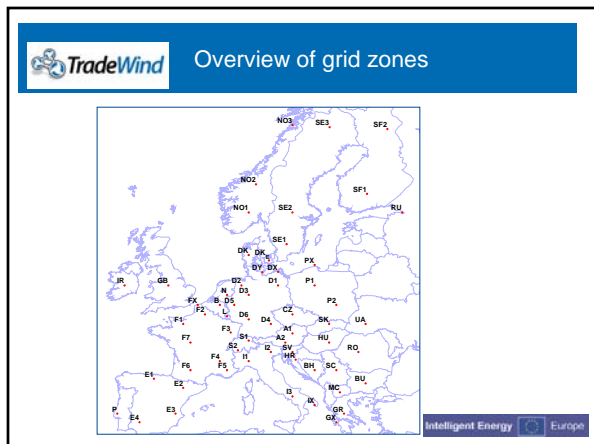
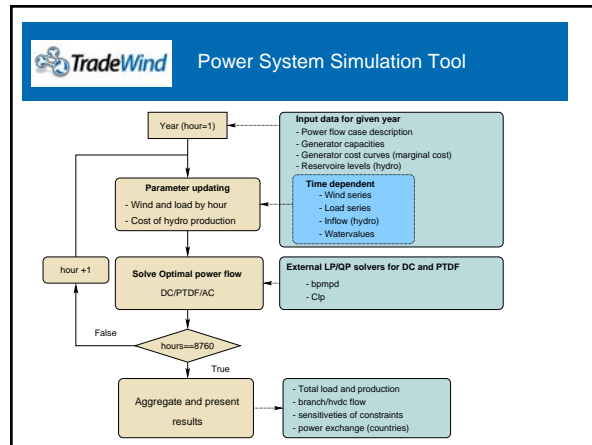
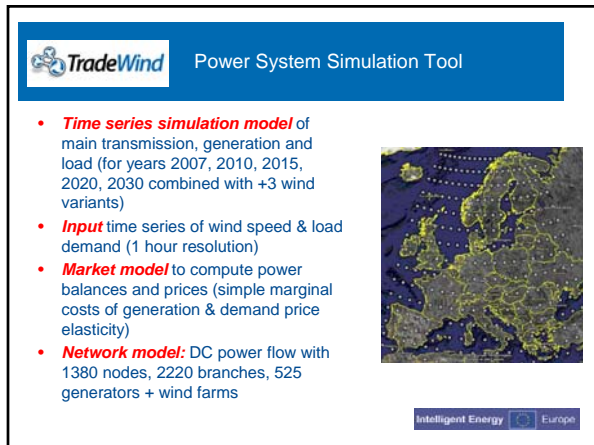
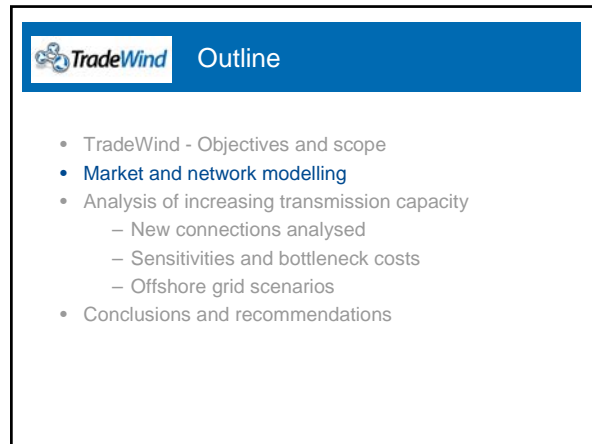
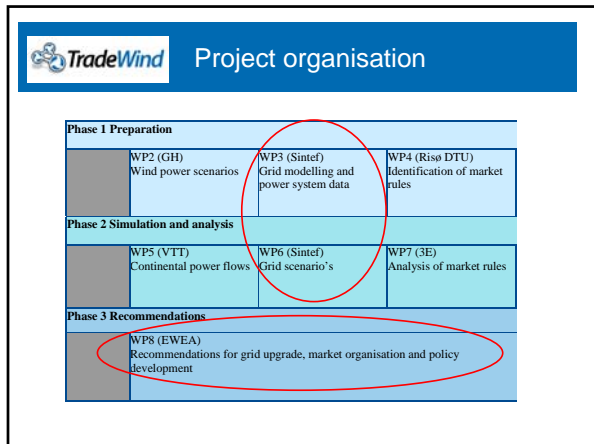

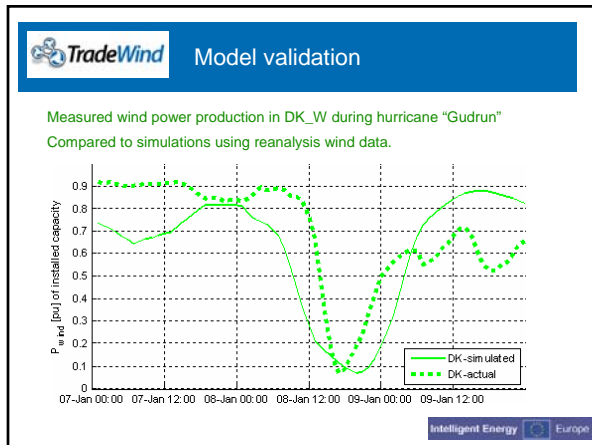
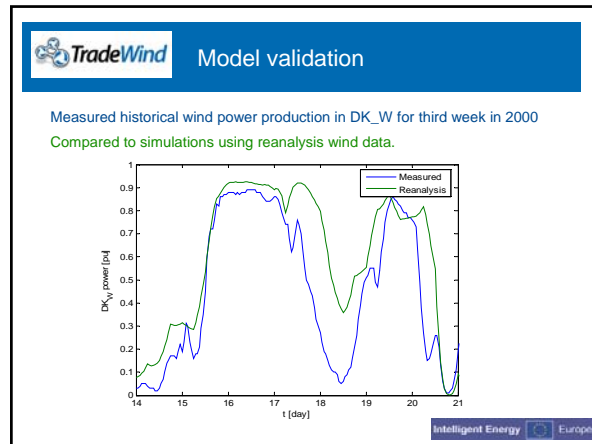
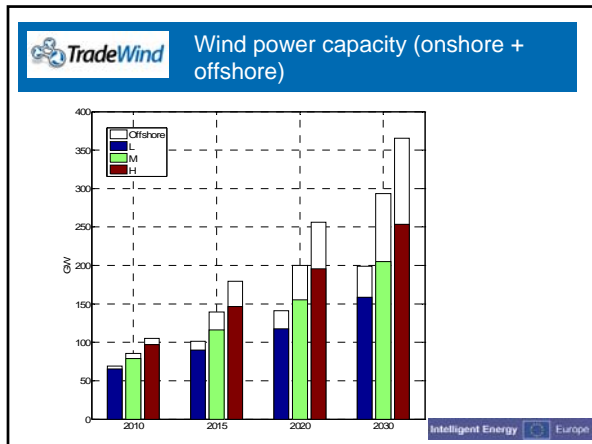

- ### TradeWind Outline
- TradeWind - Objectives and scope
 - Market and network modelling
 - Analysis of increasing transmission capacity
 - New connections analysed
 - Sensitivities and bottleneck costs
 - Offshore grid scenarios
 - Conclusions and recommendations

- ### TradeWind Analysis of increasing transmission capacity
- Main Objective: *The assessment of increasing capacity on selected transmission corridors*
 - How do we select?
 - Stage 1: Looking at known plans and necessary upgrades
 - Stage 2(3): Identify critical corridors using sensitivity calculations
 - How do we assess?
 - Computing operational costs due to transmission constraints ("bottleneck costs")
 - Tool: An integrated power market and network simulation model (PSST)

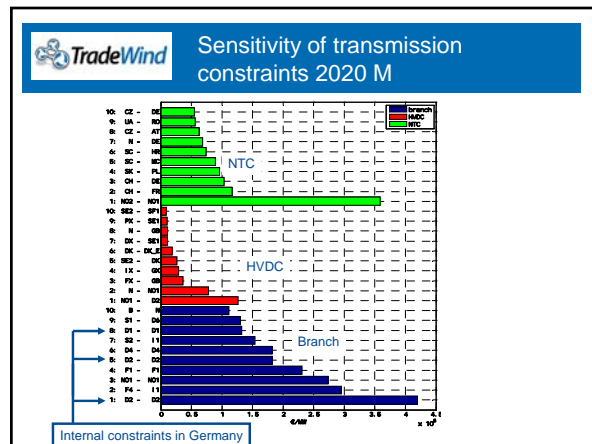

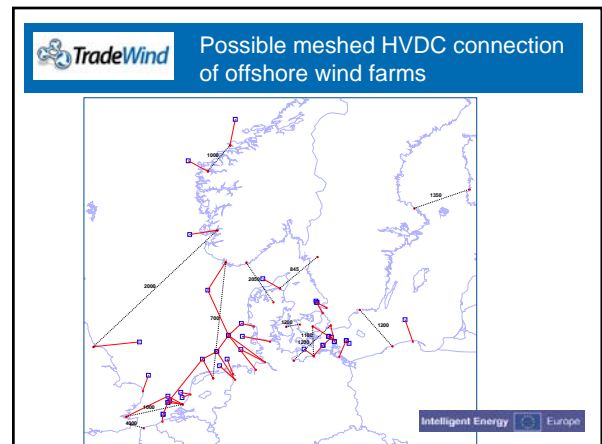
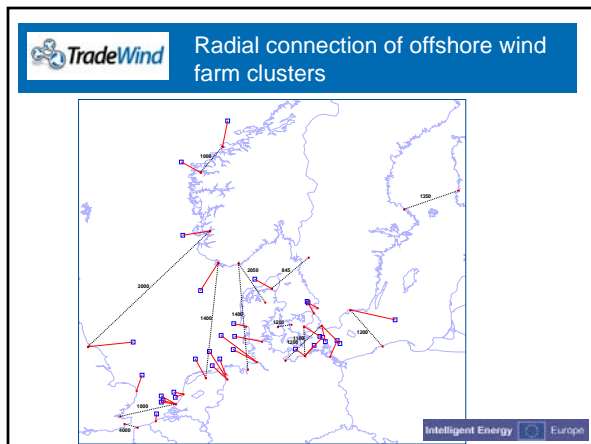
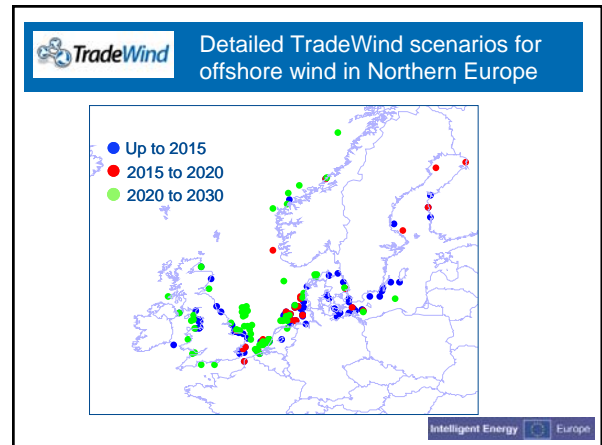
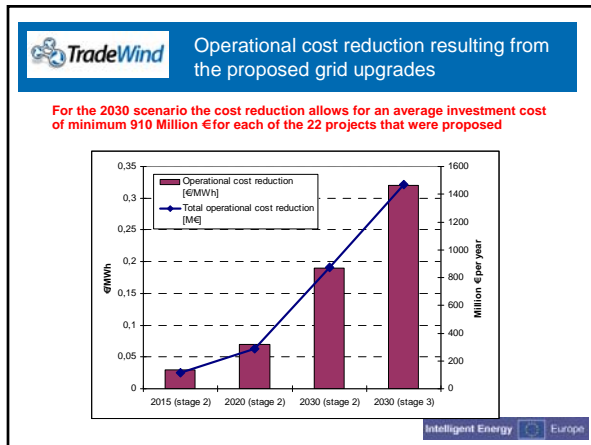
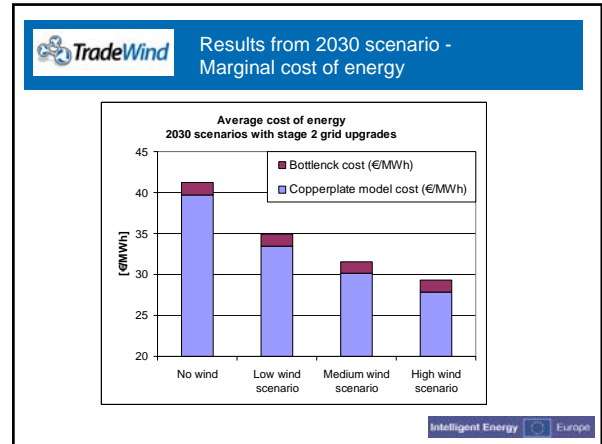
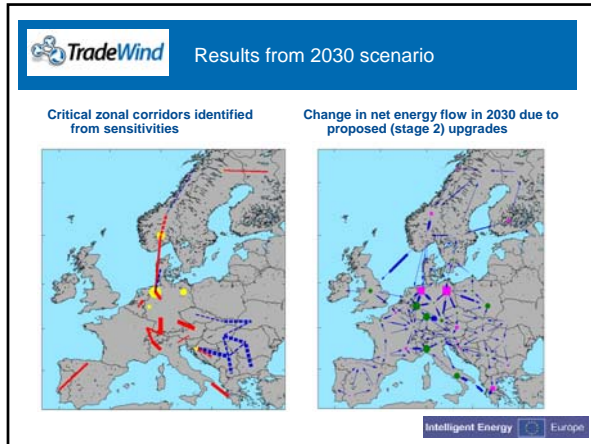

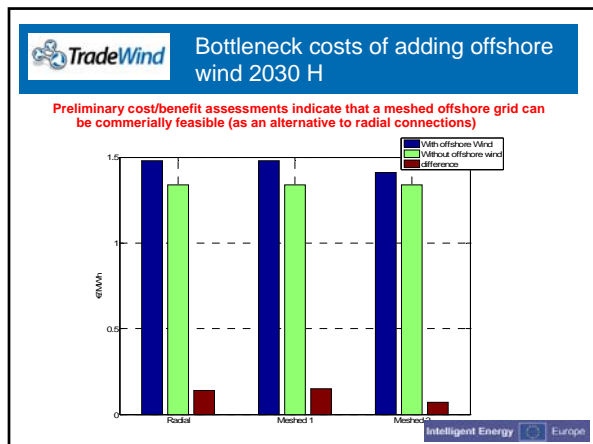

- TradeWind** Outline
- TradeWind - Objectives and scope
 - Market and network modelling
 - Analysis of increasing transmission capacity
 - New connections analysed
 - Sensitivities and bottleneck costs
 - Offshore grid scenarios
 - Conclusions and recommendations

- TradeWind** General conclusions
- TradeWind is the first project to analyse wind power cross-border transmission and market design at the European level.
 - Significant macro-economic cost savings can be achieved
 - due to reduced marginal costs of electricity as wind power replaces conventional sources
 - Cross-border transmission upgrades and a sound market design is necessary to maximise benefits

- TradeWind** Summary and conclusions - Transmission upgrades
- Analyses have been presented on grid capacity upgrades and wind impact on bottlenecks in Europe
 - Hourly simulations over the scenario year are carried out using the Power System Simulation Tool (PSST) assuming an ideal market
 - Grid upgrades, in addition to those assumed in existing plans, have been proposed in this study by using a methodology based on sensitivities for ranking of critical connections
 - For the 2030 scenario the cost reduction allows for an average investment cost of minimum 910 Million € for each of the 22 projects that were proposed

- TradeWind** Summary and conclusions (offshore grid)
- The benefits of building a meshed offshore grid in the North Sea is assessed by comparing costs and benefits with a base case with radial connection of all offshore wind farms.
 - Preliminary cost/benefit assessments indicate that a meshed offshore grid can be economically feasible (as an alternative to radial connections)
 - As an alternative to further reinforcements on mainland connections one should consider building a stronger offshore grid than exemplified in the simulation case study.

- TradeWind** Summary and conclusions (Market design)
- The European electricity market needs the following major design characteristics in order to enable efficient wind power integration:
 - Features for intra-day rescheduling of generators and trade on an international level.
 - Application of intra-day wind power forecasting in order to minimise additional reserve requirements.
 - The availability of sufficient interconnection capacity to enable prices to converge.



Recommendations

- Proposed grid upgrades should be analysed in further detail
- Power market design
- Wind power integration:
 - Geographical spread is desirable to maximise capacity credit
 - To minimise need for grid upgrades and additional reserves
- The model of the European power system and the collected TradeWind data on load, generation and grids should be further developed and used.



Summary and conclusions (Final workshop)

- Final results will be presented and discussed at a Workshop in Brussels 12 February.
- See <http://www.trade-wind.eu/>

NTNU
Norwegian University of Science and Technology

System Impacts from Large Scale Wind Power

www.ntnu.no Vindkraft FoU Seminar 2009

System Impacts from Large Scale Wind Power

Motivation: European Goal of 20% in 2020

CONTRIBUTION OF WIND POWER (TWh) TO ELECTRICITY GENERATION 1995 – 2020, EU

	1995	2000	2010	2020
Total Electricity Generation (TWh)	2,307	2,572	3,064	3,511
Wind Electricity Generation (TWh)	4.1	22.4	168	435
Share of Wind (%)	0.2%	0.9%	5.5%	12.1%

Ref: EWEA, Wind power targets for Europe, 2003

www.ntnu.no Vindkraft FoU Seminar 2009

System Impacts from Large Scale Wind Power

System Impacts of Wind Power

Ref: "The impact of large scale wind power production on the Nordic electricity system; 2004; Hannele Holttinen, VTT

www.ntnu.no Vindkraft FoU Seminar 2009

System Impacts from Large Scale Wind Power

Variations in Wind Power Production:

- Large geographical separation might increase predictability and reduce variability as well as zero production times

Ref: "The impact of large scale wind power production on the Nordic electricity system; 2004; Hannele Holttinen, VTT

www.ntnu.no Vindkraft FoU Seminar 2009

System Impacts from Large Scale Wind Power

Designated Area

Selection based on:

- Installed Wind power Capacity
- Future Wind power Installations
- Installed Hydro power Capacity
- Cross linking
- Electricity Markets

www.ntnu.no Vindkraft FoU Seminar 2009

System Impacts from Large Scale Wind Power

Variations in production and Smoothing Effects

- Determine the smoothing effects on a European level

Ref: "The impact of large scale wind power production on the Nordic electricity system; 2004; Hannele Holttinen, VTT

www.ntnu.no Vindkraft FoU Seminar 2009

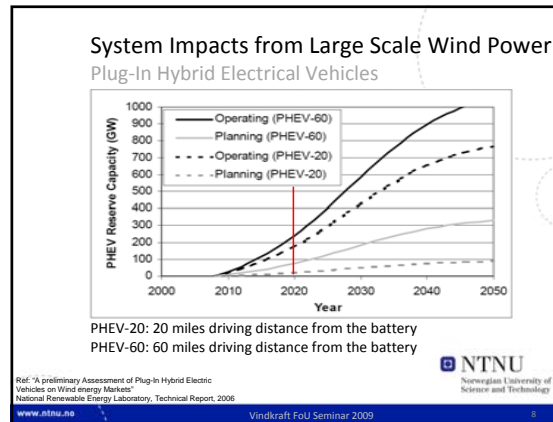
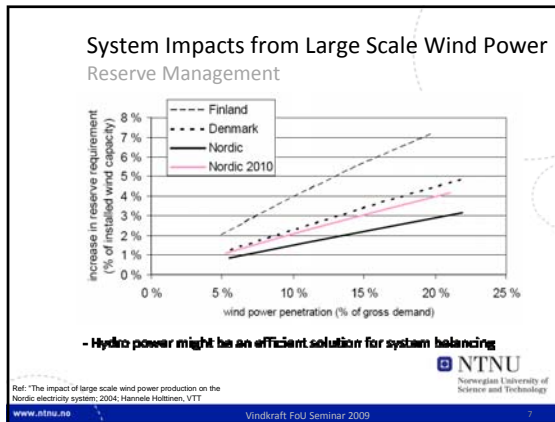

System Impacts from Large Scale Wind Power Conclusion

- Integrate large scale Wind power into the power system
- Hydro Power might be an efficient and secure possibility for balancing the system
- Hybrid Cars/ Electric Vehicles might be used as storage capacity

→ Find an efficient and secure design and operation of the overall system

NTNU Norwegian University of Science and Technology

www.ntnu.no Vindkraft FOU Seminar 2009

System Impacts from Large Scale Wind Power

Backup

NTNU Norwegian University of Science and Technology

www.ntnu.no Vindkraft FOU Seminar 2009

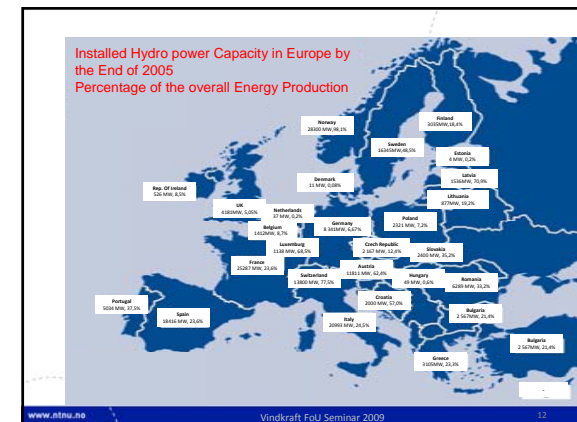
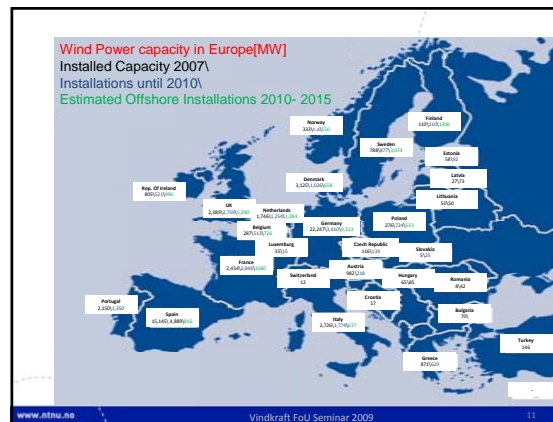

Statnett

Statnett - offshore kraftnett

Kjartan Hauglum, 22. januar 2009

Statnett

Mulig skisse for et offshore kraftnett - visjon 2020 →

- HUP2007 10-årsplan
- Tiltak for utbygging av utbygging
- Tiltak for HUP2007 10-årsplan
- VSC HVDC Tiltak 1
- VSC HVDC Tiltak 2
- VSC HVDC Tiltak 3

- ❖ Gir mulighet for:
 - salg av balansetjenester
 - kraftutveksling
 - offshore vindkraft
 - elektrifisering

Statnett

Nordsjøen et felles utbyggingsområde

EU mål 20 % fornybar innen 2020
530 TWh fornybart, 200 TWh fra Nordsjøen?

Statnett

Mulig trinnvis utbygging

Offshore kraftnett er teknisk mulig

Teknologi må være VSC HVDC

Denne skissen gir inntil ca 5000 MW økt utvekslingskapasitet

Statnett

Aktuelle utenlandsforbindelser

SKL (Sjøkabelkonsept)

Effekt: 600 MW
Investeringskost: 3 mrd NOK
Lengde: 260 km
I drift: 2014
Partner: Statnett - Energinet

Modenhet: Høy

NorNed 2

Effekt: 700 MW
Investeringskost: 5,3 mrd NOK
Lengde: 560 km
Tidligst i drift: 2015-16
Partnere: Statnett - TenneT

Modenhet: Middels +

TenneT er interessert i kabel nr 2

NORD LINK (1400)

Effekt: 1400 MW
Investeringskost: 10,7 mrd NOK
Lengde: 550 - 625 km
Tidligst i drift: 2017-18
Partnere: Statnett - E.ON Netz

Modenhet: Middels

NorGer (1400)

Effekt: 1400 MW
Investeringskost: 10 mrd NOK
Lengde: 600 km
Tidligst i drift: 2017-18 (2013 - 14 ref NorGer)
Partnere: Agfer, Lysø, ECL

Modenhet: Middels

Evaluere muligheter med National Grid

England

Effekt: 1400 MW
Investeringskost: 11,5 mrd NOK
Lengde: 745 km
Tidligst i drift: 2017-2020
Partnere: Statnett - National Grid

Modenhet: Lav +

NORD LINK Utredningsarbeid i gang sammen med E.ON Netz

Sjøfres-linker

Effekt: 1200 MW
Investeringskost: ca 1,3 mrd NOK på norsk side
Lengde: 150 km på norsk side, ca. 400 km totalt
Tidligst i drift: 2016-2020
Partnere: Statnett - Svenska Kraftnät

Modenhet: Middels

Utredning startet i samarbeid med Svenska Kraftnät

Statnett

Internasjonal fokus Kilde: TIMESONLINE 13. november 2008

European supergrid

- Supergrid
- Existing and gas pipelines
- Proposed Nabucco gas pipeline
- North Sea development
- Existing cables
- Planned cable
- Proposed cable
- Wind farms

The UK 2% of the UK's gas is imported directly from Russia

231m m³ of oil was consumed in the UK in 2007

5% of the energy generated in the UK last year came from renewable sources

150bn m³ of natural gas supplied to Europe by Russia in 2006

40% of the EU's natural gas is imported from Russia

From Russia 30% of the EU's oil comes from Russia

5.9m barrels a day (200.8 million tonnes) imported into Europe from Russia and Central Asia in 2006

Central energy hub

Electricity and gas interconnectors from Mediterranean region and planned trans-Mediterranean gas pipeline

Cables from Spain

Statnett

Viktige momenter for utviklingen offshore

- ❖ Lover og regler må etableres
 - dedikerte områder er spesielt viktig (blokktildeling)
- ❖ De samfunnsøkonomiske beste områder bør bygges ut først
- ❖ Rammebetingelser i forhold til myndighetenes ambisjonsnivå
- ❖ Muligheter for handel med ny fornybar energi vil akselerere utviklingen
- ❖ Standardisering og videreutvikling av VSC HVDC teknologi



27. januar 2009

Statnett

Hva er driverne for et offshore kraftnett ?

- ❖ Samfunnsøkonomisk lønnsomhet
- ❖ Øke verdien av norsk vannkraft
 - Norske magasiner som buffer for europeisk vindkraft
 - Salg av regulertjenester
- ❖ Eksport av ny fornybar produksjon
- ❖ Europeisk vindkraft offshore og EUs fokus på infrastruktur
- ❖ Mulig elektrifisering av olje- og gassinstallasjoner
- ❖ Offshore vindkraft i norsk sektor er i dag ikke en vesentlig driver !

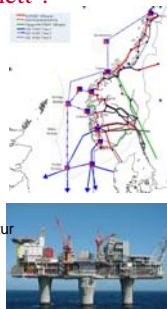

27. januar 2009

Statnett

Statnetts aktiviteter angående offshore kraftnett

- ❖ Planlegger nye kabler
 - Tilrettelegges for å knyttes til fremtidig offshore kraftnett
 - Traseer vil tilpasses mulige områder for offshore vindkraft
- ❖ Landnettet skal forsterkes betydelig
- ❖ FoU program
- ❖ Samarbeider med TSOer rundt Nordsjøen
- ❖ Fremhever vannkraftens reguleringsmuligheter
- ❖ Fremhever mulighetene for norsk fornybar produksjon



27. januar 2009

Statnett

Mulig trinnvis utbygging

Takk for oppmerksomheten

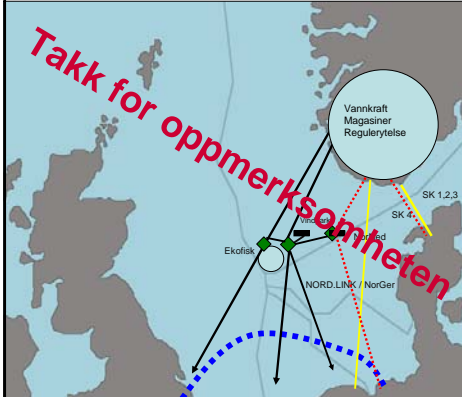

Vannkraft Magasiner Regulertjeneste
SK 1,2,3
SK
Ekofak
NORD LINK / NorGer

Teknologien må være VSC HVDC

Denne skissen gir inntil ca 5000 MW økt utvekslingskapasitet

Statnett

Optimalt design av offshore transmisjonsnett

Thomas Trötscher, Trainee SINTEF/STATNETT

Statnett

Omgivelser (ønskedrøm eller realitet...)

Mer utenlandsforbindelser
Storskala utvikling av havvind
Elektrifisering av sokkelen
Økt utnyttning av norske vannmagasiner
Ny kabelteknologi

↪

Tenke helhetlig om offshore nett
Ikke bygge parallell infrastruktur

26. januar 2009 2

Statnett

Sørlige Nordsjøen

26. januar 2009 3

Statnett

Sørlige Nordsjøen

26. januar 2009 4

Statnett

Problemstilling

Problem: Koble planlagte (offshore) vindparker og oljeplattformer til nettet på land

Mål: Optimal samfunnsøkonomisk nytte

Inndata: Plassering og ytelse på vindparker, aktuelle tilknytningspunkter, statistikk over vinddata og kraftpriser, forbruk på oljeplattformer

Ukjente: Hvor skal det bygges kabler, og med hvor høy kapasitet

Utfordring

26. januar 2009 5

... antall mulig konfigurasjoner vokser eksponentielt med antallet tilknytningspunkter. Umulig å se på alle muligheter enkeltvis

Statnett

Løsning... et optimeringsproblem

- ❖ Det er mulig å oversette problemet til et standard optimeringsproblem ved å gjøre noen viktige antakelser:
 - Konstante eller lineære marginalkostnader
 - Fysisk representasjon av nettet må være linearisert
- ❖ Variasjon i vindkraftproduksjon og kraftpriser representeres ved et tilfeldig utvalg

$$F(X, L) = \sum_m \sum_g (X_{m,g} * P_{m,g}) * f * w_m + \sum_l L_l * C_l$$

26. januar 2009 6

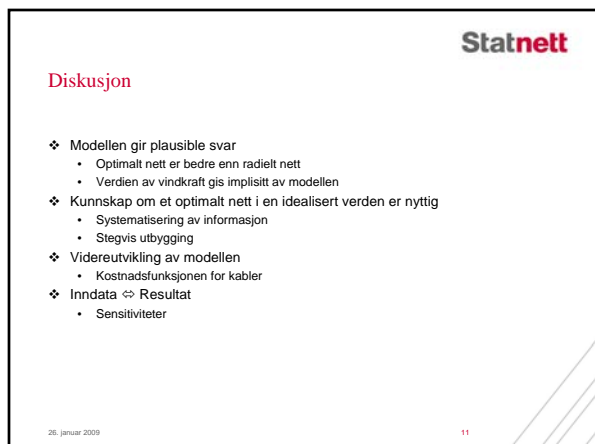
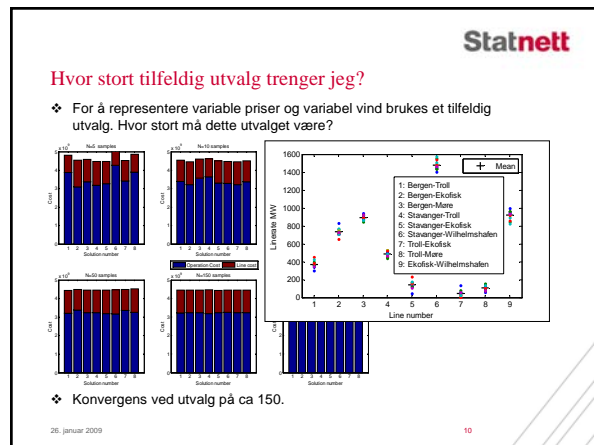
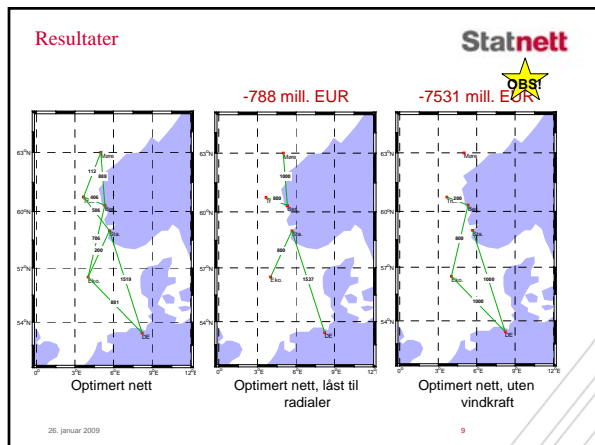
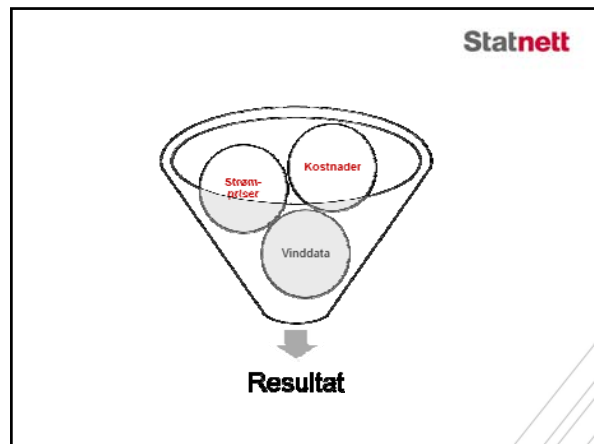
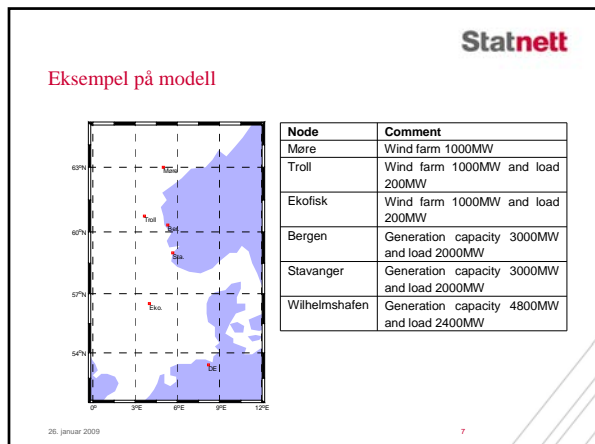

HVAC connection for offshore Windmill Parks



Georg Balog
Vindkraft seminar
Trondheim 22-23/01/09



1

The subject

- AC Submarine power transmission over large distances, with cables
 - ◆ The AC transmission with three-core XLPE insulated cables, up to 245 kV
 - ◆ The AC transmission with single-core XLPE insulated cables, up to 420 kV
 - ◆ The compensated equally at both ends
 - ◆ Losses are included for all system parts

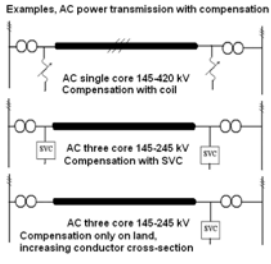
Examples, AC power transmission with compensation





2

The AC submarine transmission system with three-core cables

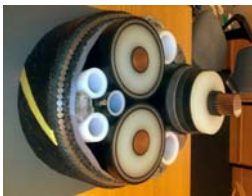
- The AC system consists of well known passive elements
 - ◆ Require much less space onboard a platform
 - ◆ Only passive components onboard
 - ◆ Cable laying and protection, as for one cable
 - ◆ Static VAr compensators may be necessary for maintaining voltage quality, on shore
 - ◆ Charging current has to be considered when designing the system



Wolf Island 245 kV/200 MW 3x500 mm² Cu



3

Advantages using XLPE for AC

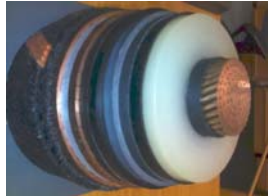
- XLPE insulation has low dielectric constant, $\epsilon_r = 2,5$.
 - ◆ => Low charging current.
- Low dielectric losses, $\text{tg}\delta \leq 0,0005$.
- High voltage withstand level.
- Maximum operating temperature 90°C.
- AC submarine cable systems are developed up to 245kV 3-core (2008) and 420 kV single core (2007) with XLPE insulation.





Ormen Lange 420 kV/1000MW 1x1200 mm² Cu

4

The AC cable modelling

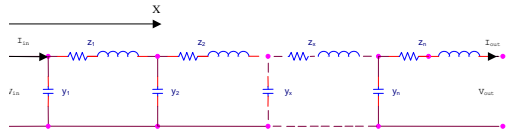
- In cables the capacity is high and impedance low
- Long cables has to be modelled with distributed parameters, some of which changes with location





5

The two extreme charging current schemes

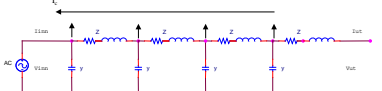
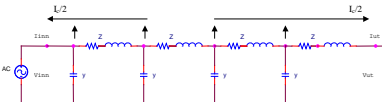
- All charging current flows to one end/not compensated
- The charging current flows equally to both ends/comp.

6

The basis for calculation AC system

- Single line model of the transmission system.

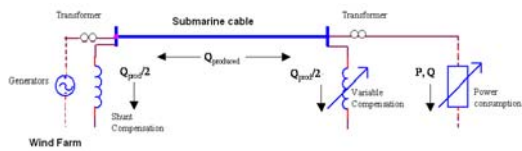

7

Production Windmillfarm

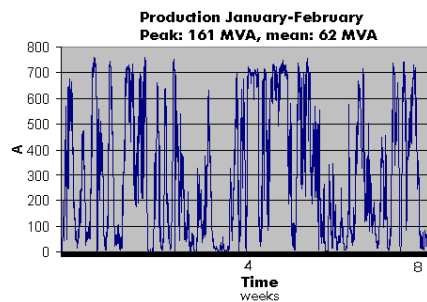

8

Criteria for viable AC transmission

- Max. voltage swing $\pm 10\%$ between no-load and full load state at the receiving end.
- Max. transmission losses $\leq 10\%$ at full load
- Maximum rated current is according to IEC60 287/IEC 60853.



9

Premises for Submarine cables:

- Three core submarine cable.(except 400 kV)
- Ambient temperature in seabed: 10°C
- Burial depth: 1m
- Thermal resistance in seabed: 0.7mK/W



10

Results Submarine cables

- The considered submarine cables:

- ◆ TKZA 420 kV $1 \times 1200\text{mm}^2$. (single core cables)
- ◆ TKRA 245 kV $3 \times 1 \times 1000\text{mm}^2$.
- ◆ TKRA 170 kV $3 \times 1 \times 1000\text{mm}^2$.
- ◆ TKRA 145 kV $3 \times 1 \times 1000\text{mm}^2$.

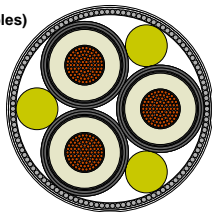

11

Limits of transmission capacity, Submarine HVAC cables

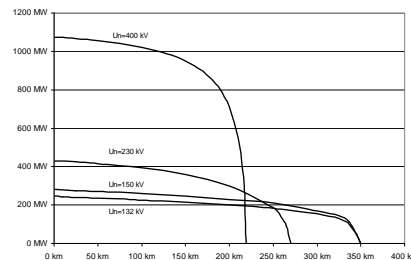

- 400kV: $>1000\text{ MW}$ up to 100 km.
- 245 kV: $\checkmark 200\text{ MW}$ to 250km.
- $\checkmark 400\text{ MW}$ to 80 km.



12

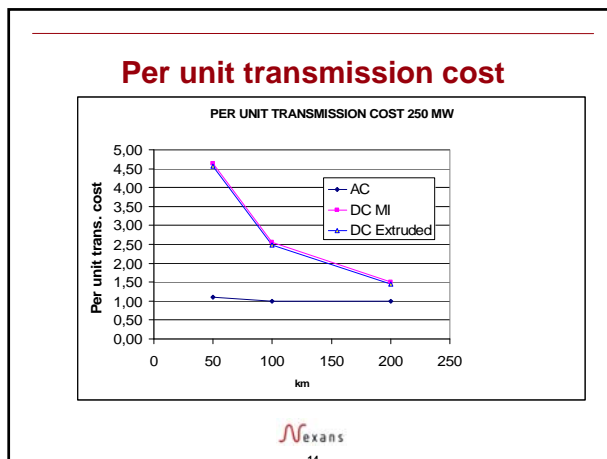
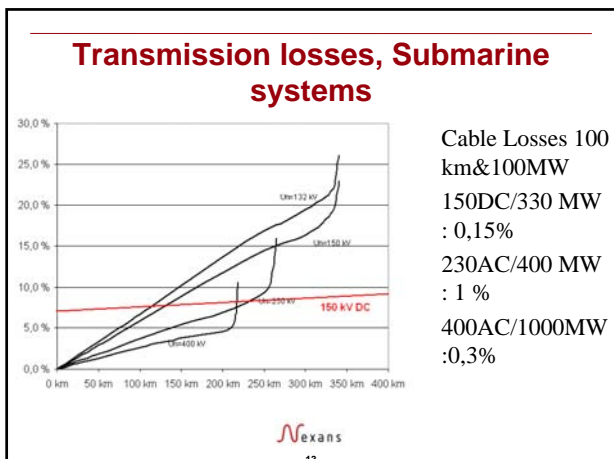

AC XLPE State-of-the-art

	3-core	1-core	dynamic
Voltage, kV	170 245	420	100
Power, MW	200 200	1000	70
Length, km	42 8,3	2,7	2
depth, m	30 22	200	400
Future	245kV 400 MW	100 km Flexible joint	230/400 kV

16

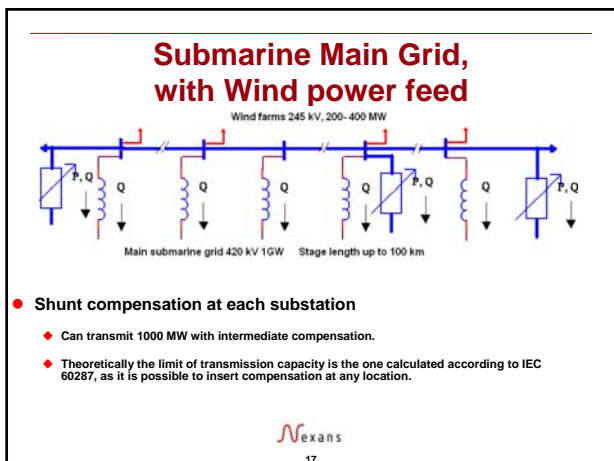

Conclusion

- A transmission system based on AC XLPE cables is cost effective with immediate compensation, if no special requirements are present, (f.ex. 50/60 Hz)
- The losses in AC 420 kV submarine cable system are low < 3% at 100 km
- The AC system is operated with rugged, well known components and the only alternative for true grid operation
- If you can make it with AC do it!

Thank you

18



Wind Power FoU Seminar – Offshore, Trondheim January 22th 2009 Lillgrund Offshore Wind Farm



Jän Norling
Vattenfall Vindkraft AB

2008-08-25
© Vattenfall AB

1

VATTENFALL

Vattenfall Vindkraft AB

- Vattenfall Windpower AB since 2008
- Activity in DK, FI, SE, UK, DE, PL
- Appr. 160 employee + x consultants
- Target 49 TWh wind power by 2030
- Electricity to 10 million households
- 1/3 Nordic 1/3 UK 1/3 Central Europe



2008-08-25
© Vattenfall AB

VATTENFALL

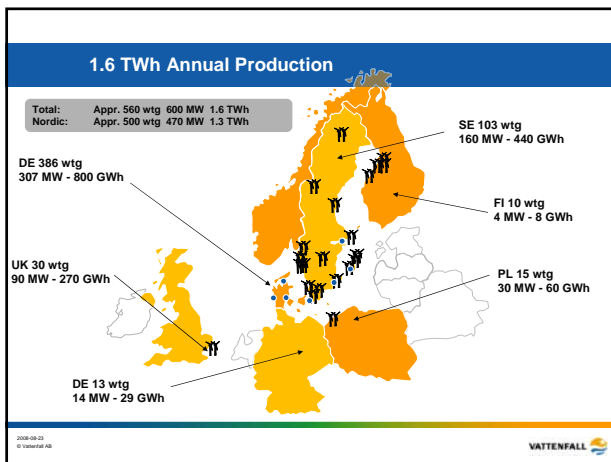

Vattenfalls Existing Offshore Wind Farms



- Lillgrund 110 MW (SE)
- Yttre Stengrund 10 MW (SE)
- Utgrunden 10 MW (SE)
- Kentish Flats 90 MW (UK)
- Horns Rev 160 MW (DK)*

* Vattenfall owns 60 % of Horns Rev

2008-08-25
© Vattenfall AB

VATTENFALL

Offshore projects in development phase

- **Kriegers flak**
 - 640 MW, Max 2,1 TWh/yr
 - Possible construction 2013
- **Trolleboda**
 - Ca 150 MW, Ca 500 GWh/år
 - Possible construction 2012
- **Taggen**
 - Ca 300 MW, Ca 1 TWh/år
 - Possible construction 2013
- **Thanet 300 MW**
- **Ormonde 150 MW**
- **Dantysk 400 MW**
- **Alphaventus 60 MW**
- **Borkum Riffgrund**



2008-08-25
© Vattenfall AB

VATTENFALL

Lillgrund Offshore Wind Farm

- Malmö Municipality (Öresund)
- Electricity to 60 000 homes
- 6 km to coast
- 48 Wind Turbines
- 2.3 MW each
- 110 MW
- 330 GWh
- 4-8 m water depth



2008-08-25
© Vattenfall AB

VATTENFALL

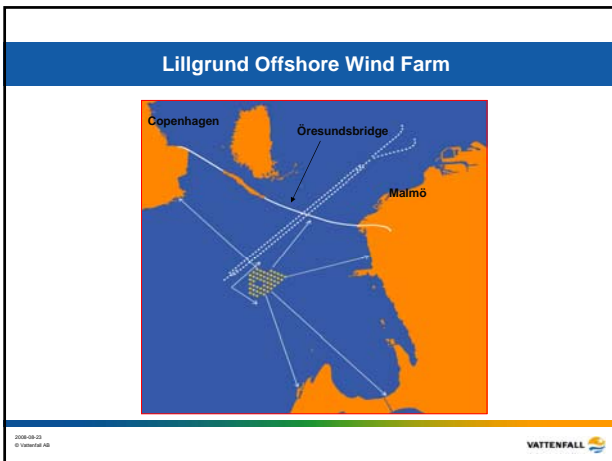

Lillgrund Offshore Wind Farm – Time Schedule

Start of permit process	1997
Procurement	Nov 2004
All necessary permits received	Spring 2005
Investment decision	Aug 2005
Purchase finished	Feb 2006
Construction	Spring 2006 – Autumn 2007
Commissioning	Dec 2007

2008-08-23
© Vattenfall AB

VATTENFALL

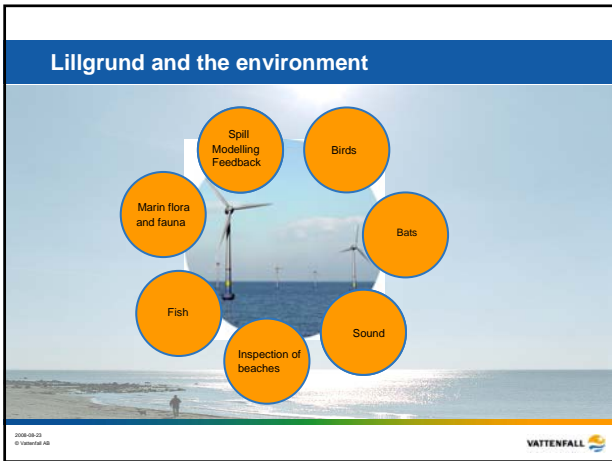

Contractors

Procurement in accordance with Public Procurement Act

Turbines and electrical systems
Siemens Wind Power A/S
Contract with Siemens includes a 5-year service contract

Foundations and seabed preparation
Pihl & Sohn A/S – Hochtief Construction AG

2008-08-23
© Vattenfall AB

VATTENFALL

Casting and towing of foundations

- Casting in Poland Jan – Nov 2006, barge to Lillgrund, approx. 24 hours
- Weight of foundations: 1300 ton excluding ballast
- Diameter at bottom: 16–19 m, height: 11–15 m, diameter of cylinder: 5 m

2008-08-23
© Vattenfall AB

VATTENFALL

Dredging

- Sea bed prepared by dredging and filling with rocks
- Dredging material: 1600 – 1700 m³ per foundation

2008-08-23

VATTENFALL

Installation of foundations



Foundations installed
May 2006 – Feb 2007

2008-08-25
© Vattenfall AB

VATTENFALL

Transformer platform



Voltage 36/130 kV
Height 24 m
Diam. 20 m
Weight 520 t
Manufacturer
Bladth Industrier (DK)

2008-08-25
© Vattenfall AB

VATTENFALL

Installation of wind turbines



Tower	120 tons
Nacelle	80 tons
Rotor	60 tons
Total	260 tons
Diam. Rotor	92,4 m
Hub Height	68,8 masl
Tot. Height	115 m
Swept area	6800 m ²
Rotor speed	6 – 16 rpm

2008-08-25
© Vattenfall AB

VATTENFALL

Installation of wind turbines



2008-08-25
© Vattenfall AB

VATTENFALL

Opening ceremony on the 3rd of June 2008



2008-08-25
© Vattenfall AB

VATTENFALL

Experiences Lillgrund

326 GWh production 2008, calculated 330 GWh
94 % availability 2008
despite 1-yr services / 1 week electrical interrupt
High wake losses, appr. 20 % due to 300/400 m spacing
Shift of a few components, reliable contractor (Siemens)
One electrical failure just before the opening ceremony

2008-08-25
© Vattenfall AB

VATTENFALL

Vind, Drift og Vedlikehold

Offshore vindressurskartlegging, Øyvind Byrkjedal, Kjeller Vindteknikk

Hvordan havbølger påvirker vindprofilen og turbulens i atmosfæren,
Alastair D. Jenkins, Forsker UiB

Effects of wakes in offshore wind farms, S. Frandsen, Senior scientist,
Risø DTU

Airborne Maintenance & Repair (M&R) Applications for Wind Turbines,
Ben-David Hanan, WindSL

Drift og vedlikehold av offshore vindkraftverk, Jørn Heggset, Seniorforsker
SINTEF Energiforskning

Bøyeteknologi for måling av vind, bølger og strøm; Jan-Petter Mathisen,
Fugro Oceanor



Offshore vindressurskartlegging

Øyvind Byrkjedal

Innhold

- metoder for offshore ressurskartlegging
- modelldata
 - metodikk
 - vindkart
- Observasjoner
 - kyststasjoner
 - offshore stasjoner
 - satellittdata
- Usikkerheter
- Konklusjon

Hva er en mesoskala modell?

- Meteorologisk mesoskala:
 - 1-1000km utstrekning
 - Oppløser lavtrykkssystem og fronter
- Modell utviklet til bruk i værvarsling (WRF - Weather Research and Forecasting)

Mesoskala modellering - WRF

Inngangsdata:

- Vi benytter gitteravstand på 4km x 4km over et modellområde
- Meteorologiske storskala analyse data (tas inn i modellen hver 3. time)



Mesoskala modellering

- Vi starter med en initialtilstand (øyeblikksbilde av atmosfæren), og beregner oss framover i tid fra dette.
- Løser koblede ligninger for vind, temperatur, trykk, vanddamp, nedbør etc.
- Etter at modellen har kjørt en viss tid oppnår vi tisserier på alle mulige atmosfæriske parametere i alle gitterpunkt og i høyder fra bakken og opp til flere 1000m.

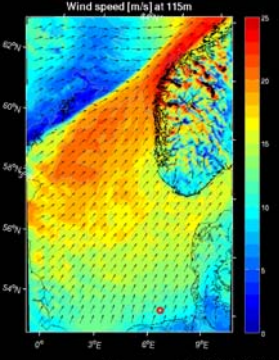

Årsmiddelvind

- Nordsjøen i 100m høyde
- Opp til 9m/s i kystnære områder
- Over 10.5 m/s utenfor Stadt.

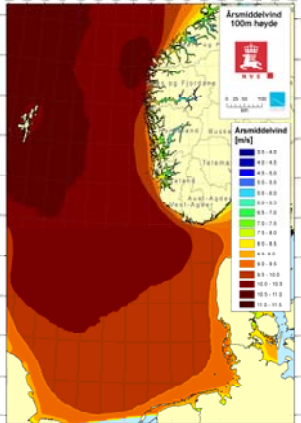

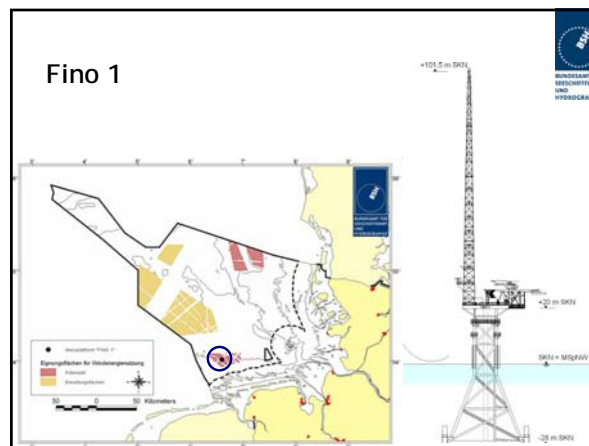
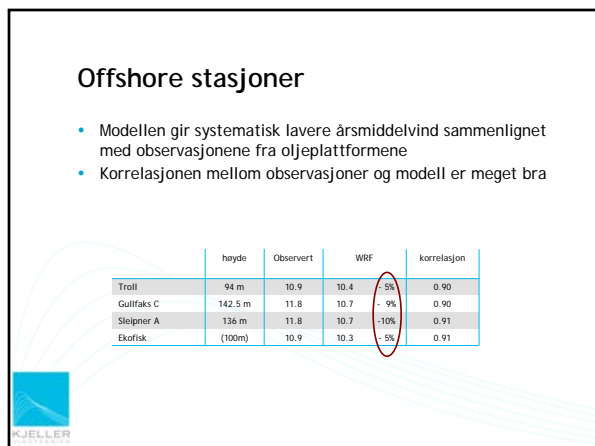
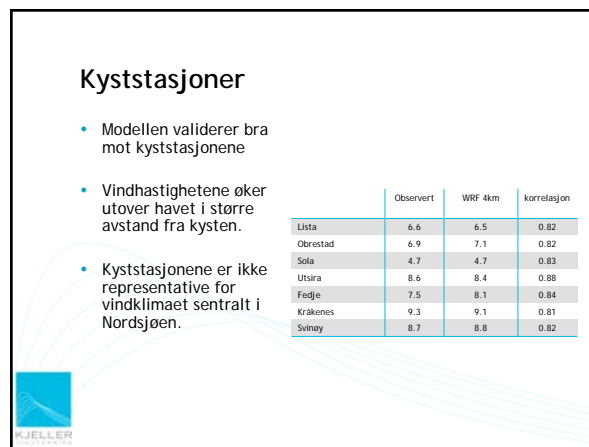
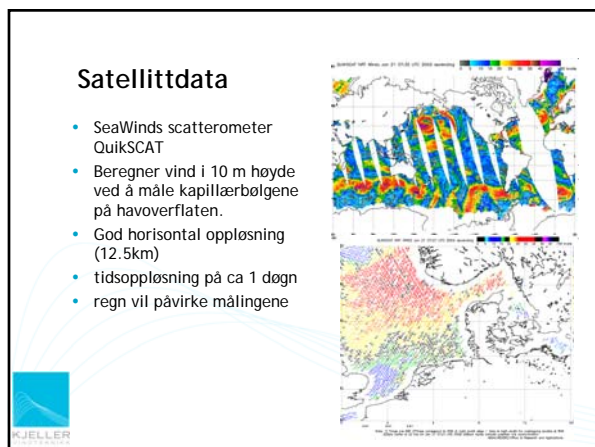
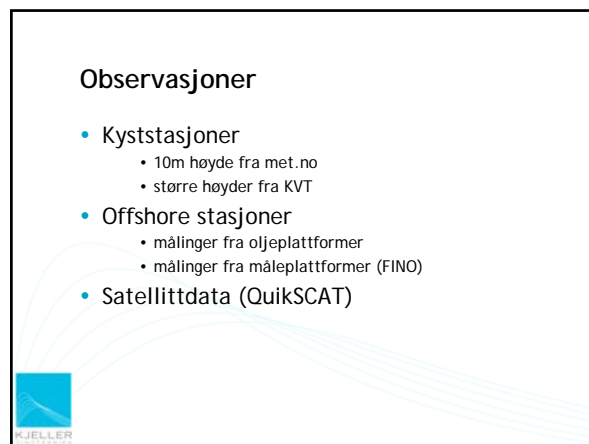
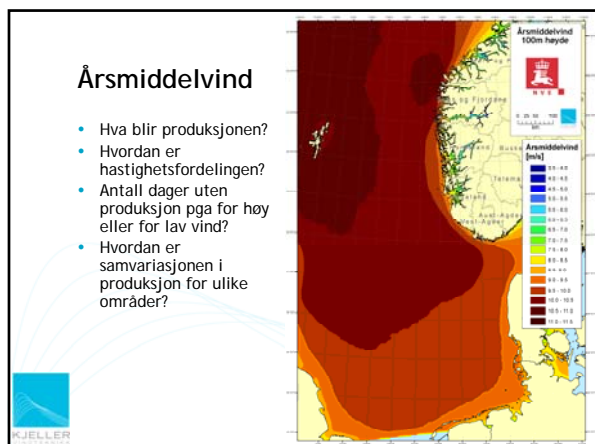

Offshore stasjoner

- Modellen gir systematisk lavere årsmiddelvind sammenlignet med observasjonene fra oljeplattformene
- Korrelasjonen mellom observasjoner og modell er meget bra
- Modellen gir også noe lavere årsmiddelvind enn FINO 1 (kilde: BSH)

	høyde	Observert	WRF	korrelasjon
Troll	94 m	10.9	10.4	-5%
Gullfaks C	142.5 m	11.8	10.7	-9%
Sleipner A	136 m	11.8	10.7	-10%
Ekofisk	100m	10.9	10.3	-5%

	høyde	Observert	WRF	korrelasjon
Fino 1	100 m	9.8	9.6	-3%



Sleipner plattformen



Usikkerheter

- Modell og observasjoner for Sleipner viser et avvik på 1.1 m/s. Beregnet til produksjon utgjør dette ca 10%.
- Modellusikkerheten er knyttet til det vertikale vindskjæret
 - vertikal blanding av luftmassene i grenselaget, stabilitet, påvirkning fra bølger
- Usikkerhet i målingene er knyttet til plattformens påvirkning på selve målingene
 - speedup-effekter og skjermingseffekter



Speedup effekter

- I følge Landberg: Wind energy (2000) vil målinger tatt fra en mast plassert på toppen av en bygning være påvirket av speedup effekter.

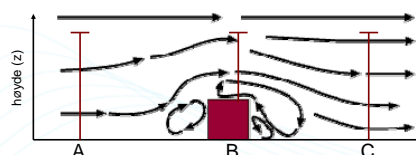

- Vi vil måle høyere vindhastighet i B enn i A og C



Kan speedup over plattformen gi for høye målte vindhastigheter?

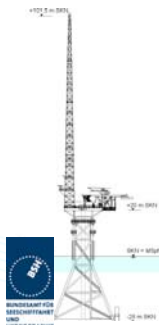

Konklusjoner

- Det er betydelige forskjeller mellom vind fra modell og vind målt ved oljeinstallasjonene i Nordsjøen
- Målingene fra oljeinstallasjonene kan være påvirket av speedup-effekter. En må derfor være forsiktig med å benytte disse målingene direkte i vindressurskartleggingsformål





Vindkraft FoU Seminar - fokus på offshore
Trondheim, 22.-23.01.2009



Oversikt over hvordan havbølger påvirker vindprofilen og turbulens i atmosfæren

Alastair D. Jenkins

Geofysisk institutt, Universitetet i Bergen,
og Unifob/Bjerknessenteret for
klimaforskning

alastair.jenkins@gfi.uib.no



Sammendrag

- Innledning
- Turbulent grensesjikt
- Fluks av bevegelsesmengde
- Miles-teori, "bølgealder"
- Modeller
- Eksempler: feltmålinger
- Oppsummering/konklusjon

Innledning



- Vind over havet er vanligvis sterkere enn over land
 - Aerodynamisk ruhet er mindre over havet
- «Ruhetslementene» (havgølger) beveger seg i vindretningen
 - ⇒ «lavere friksjon»

Bakgrunn: Turbulent grensesjikt

[Nøytral stabilitet, ingen Corioliskraft]

$$U(z) = (u_*/\kappa) \log(z/z_0)$$

z = høyde, U = vindhastighet

$u_* = (\tau/\rho)^{1/2}$ = friksjonshastighet

τ = vindstress, ρ = lufttetthet

$\kappa \approx 0,4$ = von Kármán konstant

z_0 = ruhetslengde



Vertikalfluks av bevegelsesmengde



$$\tau = \rho u_*^2 = -\rho \langle u'w' \rangle \text{ (Reynoldsstress)}$$

$$= -\rho \langle (u_t + u_w)(w_t + w_w) \rangle$$

$$= \rho C_D [U(10 \text{ m})]^2$$

$\langle \cdot \rangle$: gjennomsnitt, $(\cdot)_t$: turbulent,

$(\cdot)_w$: korrelert med bølgene

u = horisontal, w = vertikal, C_D = "dragkoeffisient"

Henry Charnock (1955)



- Ruhetslementene er korte tyngdebølger
- Relevante parametere:
 - friksjonshastighet u_*
 - tyngdeakselerasjon g

$$z_0 = \alpha u_*^2 / g$$

Charnockparameteret $\alpha \approx 0,014$, men er avhengig av sjøtilstand

Miles-teori



- J.W. Miles (1957): Vekstrate av havbølger bestemmes av krumning av $U(z)$ i den kritiske høyden z_c hvor vindhastigheten er lik bølgenes fasehastighet c
 - Ved z_c er den bølgeinduserte strømningsperturbasjonen (tilnærmet) singulær

Eksempel



- Fra Jenkins 1993 *J. Phys. Oceanogr.*
- χ er lineær perturbasjon pga. en bølgekomponent
- $k = 2\pi / \text{bølgelengde}$

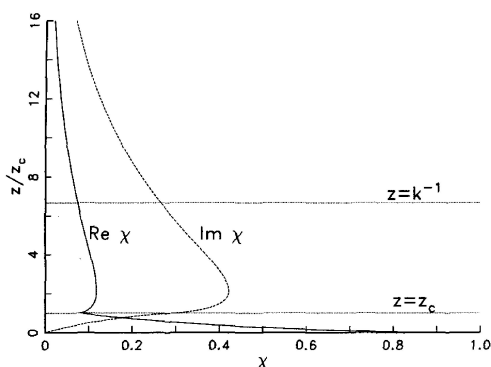

FIG. 4. Example of the solution of the Rayleigh equation for a square root velocity profile, $K = 0.15$.

Fra Jenkins 1993 JPO

“Dragkoeffisient” og “bølgealder”



- “Charnockparameteret” er avhengig av sjøtilstand
- En viktig parameter er “bølgealder” c_p/u_*
- c_p er fasehastigheten på de dominerende bølger
- C_D øker med minkende bølgealder, men minker igjen for de “yngste” sjøtilstandene (korteste strøklengdene)

Dragkoeffisient og “bølgealder”



- Neste figur viser dragkoeffisient som funksjon av bølgealder fra forskjellige observasjonsanalyser og modeller (Jenkins 1993)

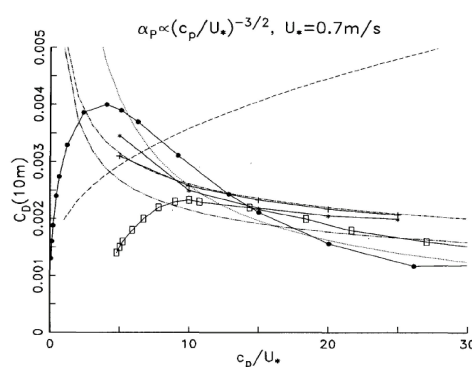

FIG. 16. Drag coefficient for $z = 10$ m with Phillips parameter $\alpha_p = 0.57(c_p/U_*)^{-3/2}$ and friction velocity $U_* = 0.7$ m s $^{-1}$. Solid lines: Model results. With solid circles, present model; with asterisks, Janssen (1989); with plus signs, Jenkins (1992); with rectangles, Nordeng (1991); dotted line: curve fitted by Geernaert et al. (1987) to field experimental results with a range of values of U_* ; close dashed line (long dashes): from the relation of Toba and colleagues [Toba and Koga 1986, Eqs. (9) and (10)]; dash-dotted line: from HEXMAX measurements (Maat et al. 1991); dash-and-three-dots line: from Lake Ontario measurements (Donelan 1990).

fra Jenkins 1993 JPO

Impulsbalanse under bølgegenerering



■ Neste figur viser fluks av bevegelsesmengde pga. bølgeinduserte bevegelser som brøkdeler av vindstress (modell, P.A.E.M. Janssen 1987)

Impulsbalanse under bølgegenerering

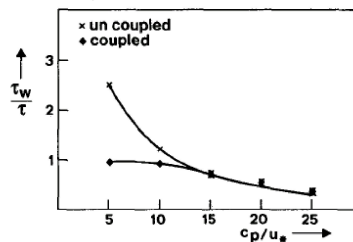
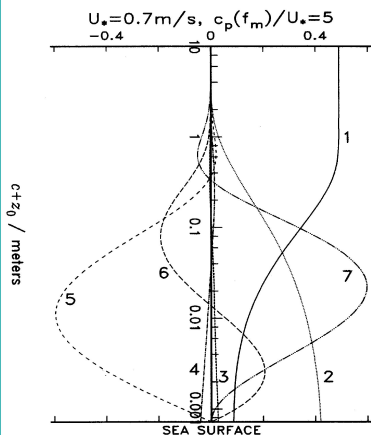

FIG. 5. Reduction of wave-induced stress due to the quasi-linear coupling of wind and waves. Crosses denote the normalized wave stress calculated from the wind profile in the absence of the long waves and diamonds denote results when there is equilibrium between wind and waves.

P.A.E.M. Janssen 1987



Vertikalfordeling (semilogaritmisk skalering) på bidrag til vertikalfluks av bevegelsesmengde (kurvilineærkoordinatmodell, Jenkins 1992 JPO):

- 1: $\langle u_i w_i \rangle$
- 2: kovarians mellom trykket og koordinatgradient ("pressure-slope covariance")
- ...

Påvirkning fra dønning (Modell, Makin 2008)

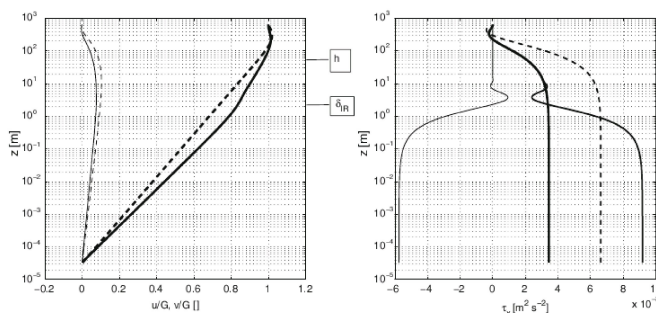

Fig. 1 Left. Wind-speed components. Thick solid line— u -component; thin solid line— v -component; swell is present, $\alpha_w = -0.62$ ($C_B = -500$, $AK = 0.05$). Thick dashed line— u -component; thin dashed line— v -component, no swell. Right. Stress components (only x -axis components are shown). Thick solid line—total stress; medium solid—turbulent stress; thin solid—wave-induced stress, swell is present. Dashed line—turbulent stress, no swell. The heights of the inner region δ_{JR} and the atmospheric surface layer h are shown by horizontal lines crossing the vertical axis

Høye vindhastigheter



■ Powell et al (*Nature* 2003) målte vindprofiler i orkaner fra fly, som viser tilsynelatende at dragkoeffisienten minker i svært høye vindhastigheter (over 35 m/s). [Blåser vinden bølgene flate?]

■ Makin 2005 forklarer dette ved å anta at sjøsprøyt reduserer friksjon. Andre modeller (Bye & Jenkins, Kudryavtsev & Makin) viser tilsvarende resultater

■ Troitskaya og Hara et al mener at grunnen er svært lav bølgealder og at vind- og bølgeretningene er forskjellige

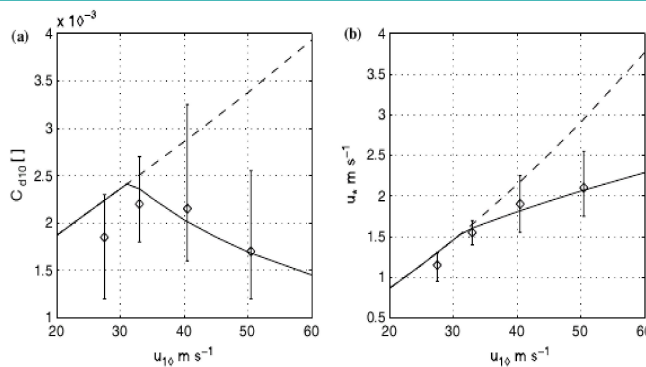
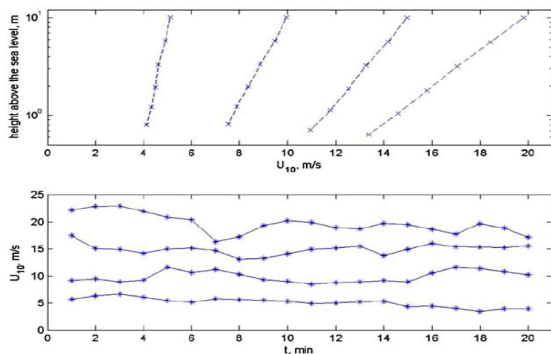

Figure 1. (a) Drag coefficient versus the wind speed, (b) Friction velocity versus the wind speed. Solid line, according to the resistance law (11); dashed line, according to the Charnock relation (3); open circles, data by Powell et al. (2003).

V.K. Makin 2005

Noen feltmålinger

BABANIN AND MAKIN: WIND TREND AND GUSTINESS ON SEA DRAG



Babanin & Makin 2008 (Lake George, New South Wales)

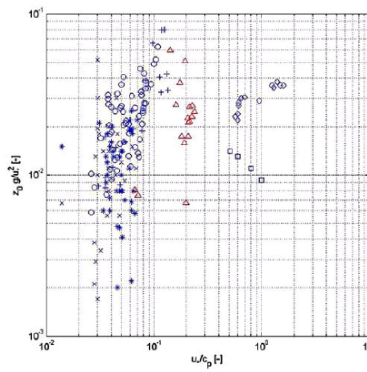

Figure 14. Charnock parameter z_0g/u^2 versus inverse wave age u/c_p . Symbols indicate data. Circles: HEXMAX [Janssen, 1997]; pluses: Lake Ontario; stars: Atlantic Ocean, long fetch; x-marks: Atlantic Ocean, limited fetch [Donelan et al., 1993]; diamonds: wave tank [Keller et al., 1992]. Data are compiled from Donelan et al. [1993], their Figure 2. Triangles: present paper.

Charnock-parameteret fra Babanin & Makin 2008

Flere målinger

- Feltemålinger, Universitetet i Uppsala
- 30 m tårn på Östergarnsholm ved Gotland i Østersjøen
- Jeg viser noen målinger fra Smedman et al. 1999 og Smedman et al. 2003 (begge i *J. Geophys. Res.*)

SMEDMAN ET AL.: AIR-SEA INTERACTION DURING SWELL

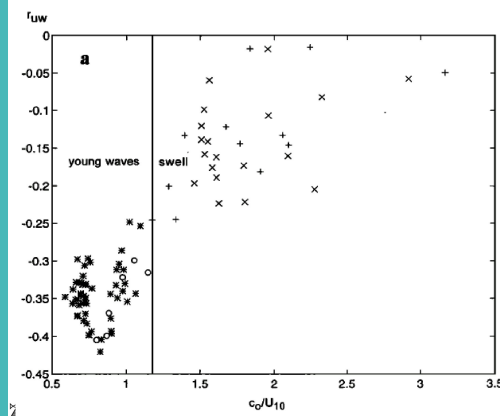

Smedman et al. 1999 JGR

Korrelasjonskoeffisient mellom u' og w' i 10 m høyde

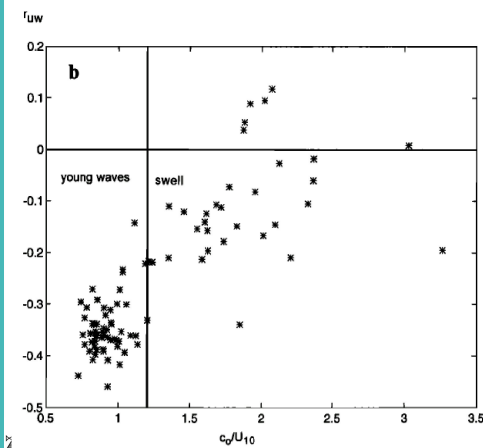

Smedman et al. 1999 JGR

Korrelasjonskoeffisient mellom u' og w' i 26 m høyde

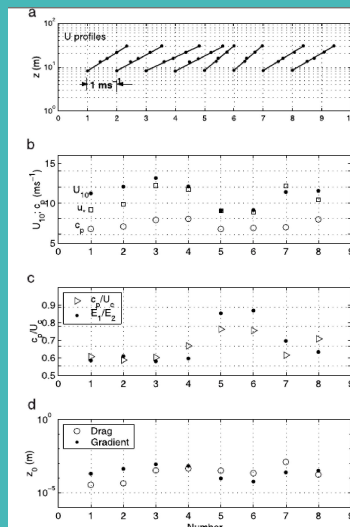

Smedman et al. 2003

Situasjoner med korte bølger, $E_1/E_2 < 0,01$

$E_1(E_2)$ = energi i bølger med fasehastighet større(mindre) enn $U(10m)$

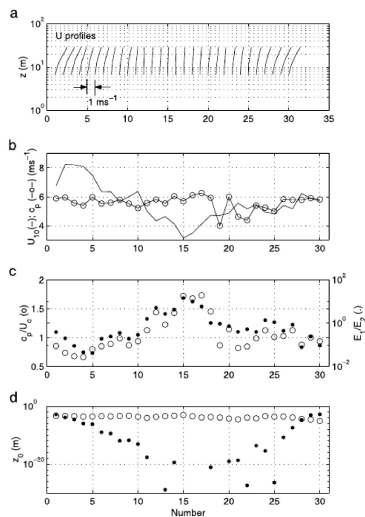

Smedman et al. 2003

Situasjoner med både korte og lange bølger

Oppsummering/konklusjon



- Havbølger kan fungere som “ruhetelementer” for turbulent strømning i atmosfæregrensesjiktet, men den effektive ruhetslengden reduseres pga. bølgepropagasjon.
- Vertikalfluks av bevegelsesmengde kan beskrives med Charnockrelasjonen: Charnock-parameteret er avhengig av “bølgealder”

Oppsummering/konklusjon



- Vindprofilen og vindstress kan beregnes med modeller basert på Miles' bølgevekstteori, med visse modifikasjoner (f.eks. slik at bevegelsesmengde i dønning kan overføres til atmosfæren)
- For $U > 35$ m/s kan dragkoeffisienten bli redusert, men mekanismen er ennå uklar

Oppsummering/konklusjon



- Nyere feltmålinger kan benyttes til å evaluere de nevnte modellene.
- Det gjenstår å skaffe en mengde pålitelige, samtidige målinger av bølge- og atmosfærebevegelser med nøyaktig faseforhold, for å vurdere den lineære responsen i Miles-teori.

DTU

Effects of wakes in offshore wind farms

Vindkraft FoU Seminar Trondheim 2009

Sten Frandsen
Wind Energy Division
RISØ DTU

DTU
National Laboratory for Sustainable Energy

DTU

Two important wake/wind farm DESIGN DRIVERS:

- The power losses
 - due to wind speed deficit in wake generated by neighbouring machines
 - due to neighbouring wind farms
- The increased structural loading
 - due to turbulence in the wakes of the neighbouring wind turbines
 - due to the general increase in turbulence inside wind farms



DTU
National Laboratory for Sustainable Energy

DTU

Considerations re. infinitely large wind farm:

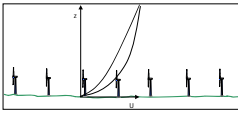

With wind turbines more steep vertical wind profile and more turbulence

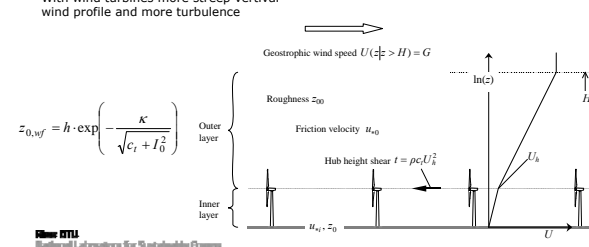

Geostrophic wind speed $U(z > H) = G$

Outer layer: $\bar{u}_{0,wf} = h \cdot \exp\left(-\frac{K}{\sqrt{c_t + I_0^2}}\right)$

Inner layer: u_{01}, z_0

Friction velocity u_{01}

Hub height shear $t = \rho c_t U_h^2$

DTU
National Laboratory for Sustainable Energy

DTU

Technical cost/benefits of offshore wind farms

- More energy over low-roughness surface of the ocean:
- ..but it could be lost again due to wake/wind farm effects; for the *infinitely large* wind farm:

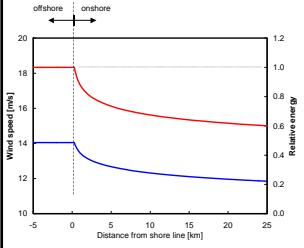
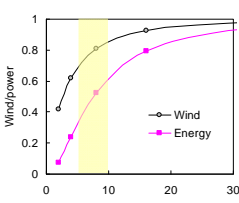
DTU
National Laboratory for Sustainable Energy

DTU

Is infinite size realistic? The offshore potential?

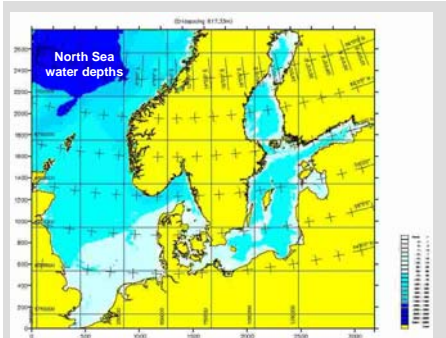

DTU
National Laboratory for Sustainable Energy

DTU

The planetary wind farm: 1000x1000km

Electricity from (deep water) offshore wind power plants:

The North Sea alone would do just about half of the world's present need.



DTU
National Laboratory for Sustainable Energy

Measurements and Data Analysis

Off-shore wind farms

Horns Rev (DONG + Vattenfall):

- North Sea, West of Jutland (13km)
- 80 x 2MW Vestas turbines – 160 MW
- Hub height 70m, Rotor diameter 80m
- Turbine-turbine distance: $7 D_t$ (560m)
- Downwind Masts: 1 x 62 + 2 x 70m

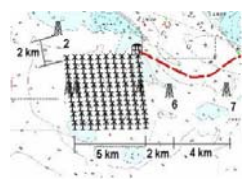

Nysted (DONG):

- Baltic Sea, South of Lolland (11km)
- 72 x 2.3MW Bonus turbines – 166 MW
- Hub height 69m, rotor diameter 82m
- T-T dist. $10.5 \times 5.8 D_t$ (857x481m)
- Downwind Masts: 2 x 50m + 4 x 70m

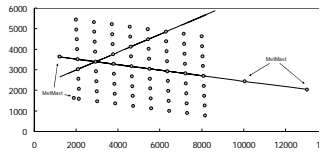

DTU
National Laboratory for Sustainable Energy

The measurements – Wind speed drop and recovery

Horns Rev, 8<U<9, wind from west

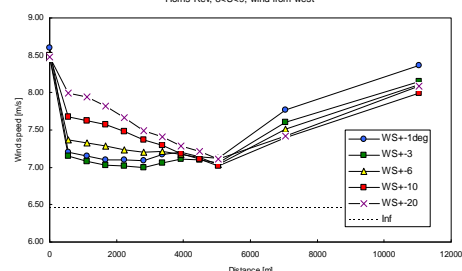

DTU
National Laboratory for Sustainable Energy

Extended WAsP modelling

Wake and shadow modelling based on WAsP
Wind farm down wind shadow

Off-shore wind farm data indicates a recovery distance of 10 km+.

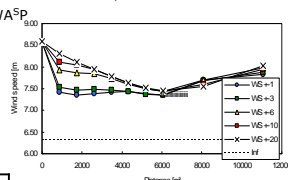

Model	Wind recovery distance
WAsP park wake model	3-4 km
Equivalent roughness	6-8 km
Added roughness	14 km
CFD	7-8 km

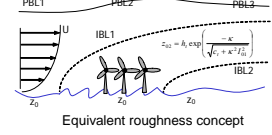

Equivalent roughness concept

DTU
National Laboratory for Sustainable Energy

Canopy model – results from Horns Rev wind farm compared to data

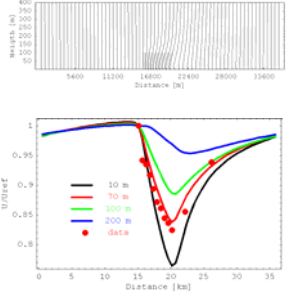

Modelled Horizontal speed perturbations rel. to incident logarithmic profile. Body-force area (wind farm) is indicated.

Calculated wind speed relative to free wind speed – compared to data

DTU
National Laboratory for Sustainable Energy

Mesoscale modelling

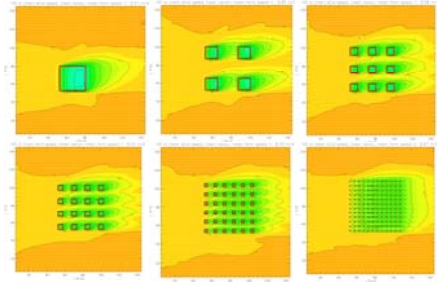

Mesoscale modelling by KAMM at 50 m above sea level

- Atmospheric condition: 1965 -1998 average at Horns Rev location
- Wind Farm representation: 0.5m surface roughness (free water: 0.0002m)
- Different WF-sub-groupings investigated (total WF-area 900 km²)

DTU
National Laboratory for Sustainable Energy

Mesoscale modelling...

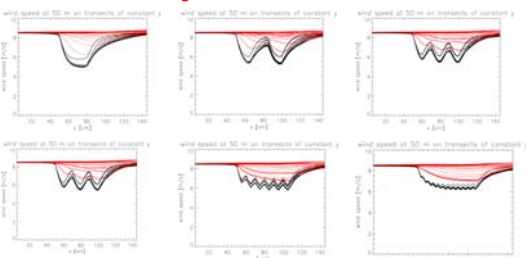

- Hardly any advantage in sub-grouping, taking the larger occupied area into account
- Sub-grouping gives a higher effective asymptotic WF speed – due to lower eff. roughness.
- **Recovery distance not significantly dependent on sub-grouping (30-60 km).**
- Results may be parameterized to be used elsewhere.

DTU
National Laboratory for Sustainable Energy

Slide 8

A1

Bemærk:

- 1) den "uendelig" store park skal sammenlignes med kurverne med den store vinkel-midling
- 2) Der slipper faktisk vind igennem til masterne for de små vinkelm-midlinger
- 3) Det kunne se ud, som asymptote værdien nås når parken er ca. dobbelt så stor som den nuværende

Administrator, 26/11/2007

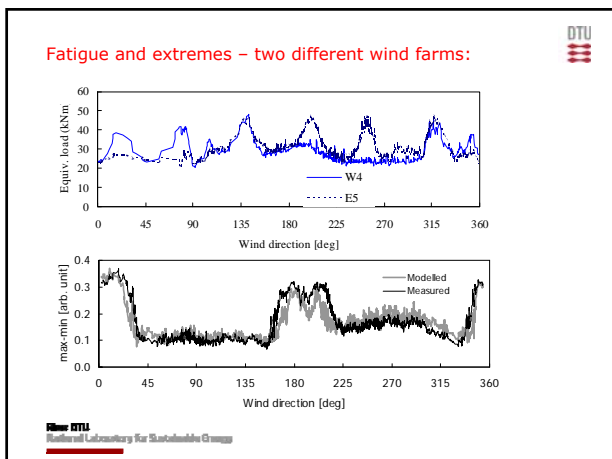
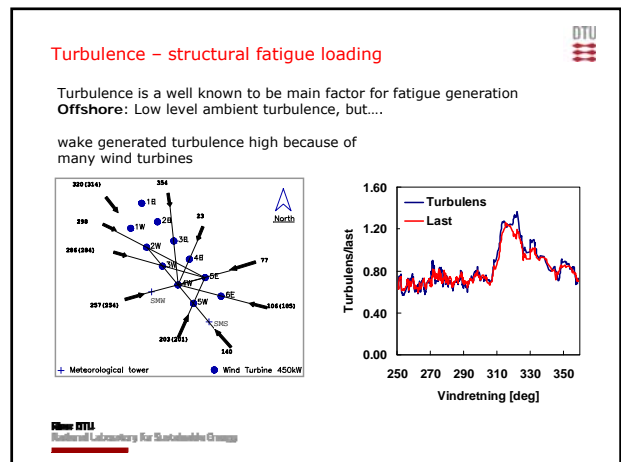
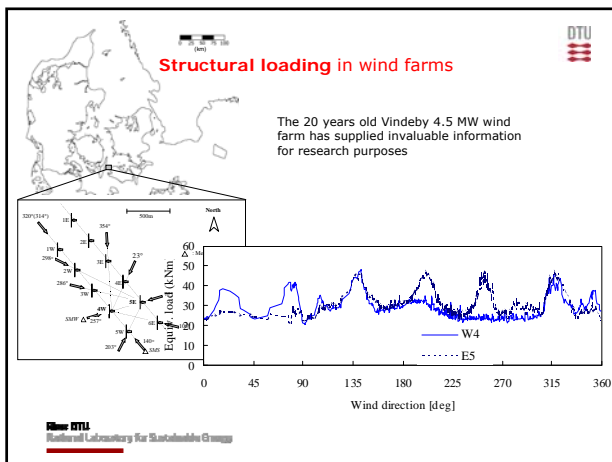
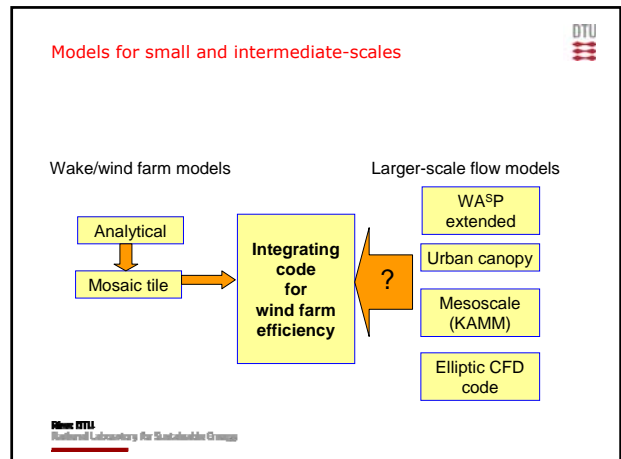
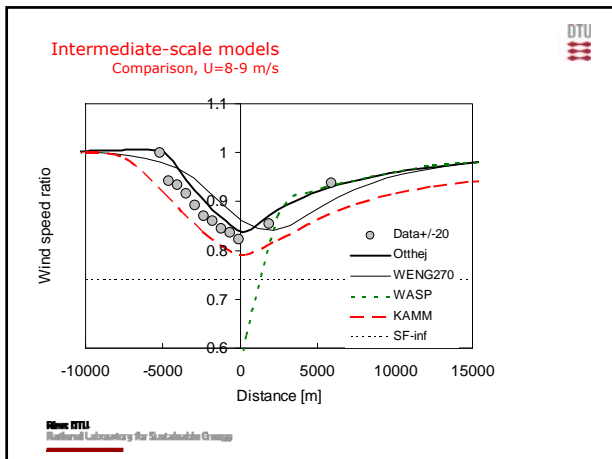

Emerging computational tools for structural response:

- Fatigue loading
 - Here, it is possible to meaningful develop an expression that covers the integrated load effect of the wind farm. From international standard IEC61400-1:
- Extreme structural response
 - It is difficult to devise "equivalent" turbulence expressions

$$I_{eff}(U) \cong \left[(1 - N \cdot p_w) I_0^m + \sum_{j=1}^N p_w I_{T,j}^m \right]^{\frac{1}{m}}$$

DTU
National Laboratory for Sustainable Energy

Conclusions



• POWER LOSSES

- Present models are predicting too small losses, i.e. are too optimistic
- ...and a new comprehensive model is needed

• STRUCTURAL LOADING

- No real benefits from low ambient turbulence offshore can be expected
- Waves in addition to wind complicates computations

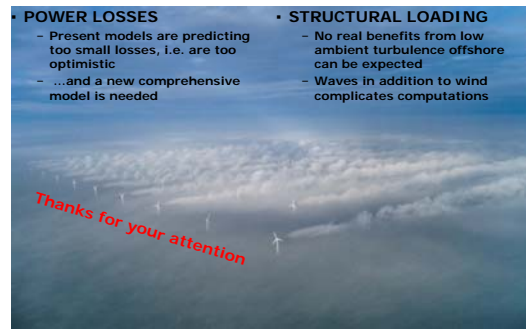

DTU
National Laboratory for Sustainable Energy



Background

- ❖ Offshore WTGs operate at sea in harsh environments, where accessibility can lead to a long Mean Time To Repair (MTTR).
- ❖ Condition Based Maintenance (CBM) is therefore essential if cost effective availability targets are to be reached.
- ❖ Offshore WTGs are subjected to various operational considerations (e.g. high loads, variable speeds, environmental conditions, etc.).
- ❖ As yet, the condition monitoring techniques appropriate for offshore WTGs have not matured.



2





HUMS

Health and Usage Monitoring/Management System

Airborne Maintenance & Repair (M&R) applications for Wind Turbines

Wind R&D seminar, Trondheim Norway
22-23 January, 2009





Airborne Total HUMS

Health and Usage Monitoring/Management System



(T-HUMS)

4



Airborne HUMS for WTGs

- ❖ **Health and Usage Monitoring Systems (HUMS)** have been successfully implemented in the Airborne Platform market for the past 15 years.
- ❖ Same airborne environment-related and matured Maintenance & Repair (M&R) implementation techniques apply to Offshore WTGs operational challenges.
- ❖ **Real-Time HUMS** based on **Diagnostics and Prognostics (D&P)** capabilities will reveal highly reliable fault detection rates of maintenance actions required, down to the WT single end component.





3



Airborne HUMS Requirements

❖ dynamic system diagnosis	❖ user-friendly interface
❖ in-flight engine diagnosis	❖ cockpit alerts & commands
❖ in-flight RT&B analysis	❖ debriefing capabilities
❖ flight regime recognition	❖ data exchange interface
❖ exceedance recording	❖ ground station analysis
❖ data storage & archive	❖ s/n based usage tracking
❖ automatic prognosis	❖ low power consumption
❖ in-flight decisions	❖ low weight

6



Airborne HUMS

- ❖ Improve flight safety
- ❖ Enhance Mission Operation
 - ❖ *Quality & Efficiency*
 - ❖ *Reliability*
 - ❖ *Fleet availability*
- ❖ Reduce costs
 - ❖ *Operational*
 - ❖ *Maintenance*
- ❖ Fleet management
- ❖ Minimal HUMS workload
- ❖ Logistics and technical upgrades



5

CH-53 T-HUMS Power Plant Monitoring

8

Total - HUMS

Monitored Assemblies: Rotors, Gearboxes, Shafts
Engines, Auxiliary / utility systems

7

T-HUMS Operations

- In-flight**
 - Act per system's advisories
 - Peace of mind – ignore body "detections"
- Download**
 - Memory is full ~ 50 flight hrs
 - If fault was detected by airborne algorithms
- Maintenance**
 - Red** - Repair starts after diagnostic review
 - Yellow** – plan maintenance in near term
 - Update IFLS after maintenance
- Planning (Sq, maintenance sq, HQ)**
 - Plan daily operations, deployments
 - Plan maintenance
 - Plan spare parts requirements

10

UAV HUMS

9

windSL
reliable wind energy

Wind Turbine Health and Usage Monitoring/Management System (WT-HUMS)

12

HUMS RHMC Remote Health Management Center

11

The WT-HUMS

- ❖ **Condition Based Maintenance (CBM)** – Replaces Preventive & Failures Repair Maintenance
- ❖ Added Income & Savings in Operations, Maintenance & Logistics :
 - **Availability** Improvement
 - **Maintenance Costs** Reduction
 - **Maintenance Team Size** Reduction
 - **Spare Parts** Reduction
 - Pre-Warranty **expiration inspection**
- ❖ **Real-Time Diagnostics and Prognostics**
 - Performed on site without further processing or expert intervention
 - Automatic Alarms
 - Zero False Alarms (FA) and Misdetections



14

The Wind Turbine HUMS

Real-Time Automatic Diagnostics & Prognostics for Wind Turbines

Dynamic Components and Overall Performance

"MAINTAIN WHEN NEEDED AND CONVENIENT, NOT WHEN URGENT"

13

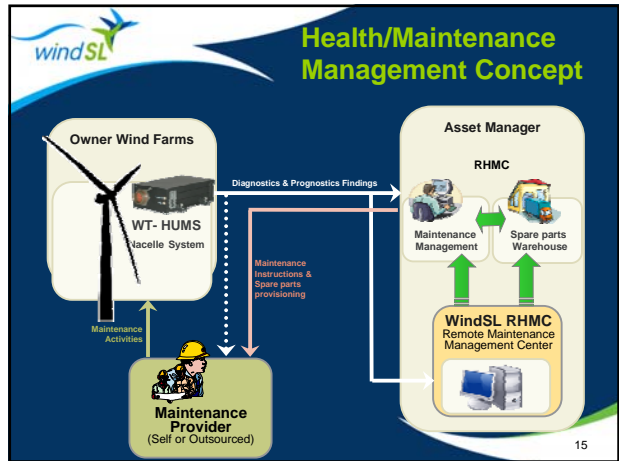
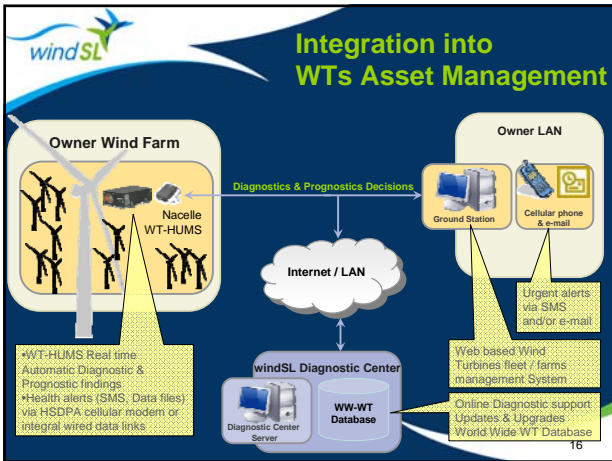

WT-HUMS System Architecture

- ❖ Real-time Automatic Diagnostics & Prognostics
- ❖ 6-16 accelerometers plus Analog, Acoustics, Temp sensors
- ❖ SCADA data analysis for Overall WT performance
- ❖ List of monitored assemblies and components:
 - ✓ Pitch mechanism and bearings
 - ✓ Gearbox
 - ✓ Main shaft
 - ✓ Main shaft bearings
 - ✓ Generator isolation mounts
 - ✓ Generator cooling system
 - ✓ Brake system
 - ✓ Coupling
 - ✓ Yaw Drives and Bearings
 - ✓ Structure vibrations
 - ✓ Blades unbalance



18

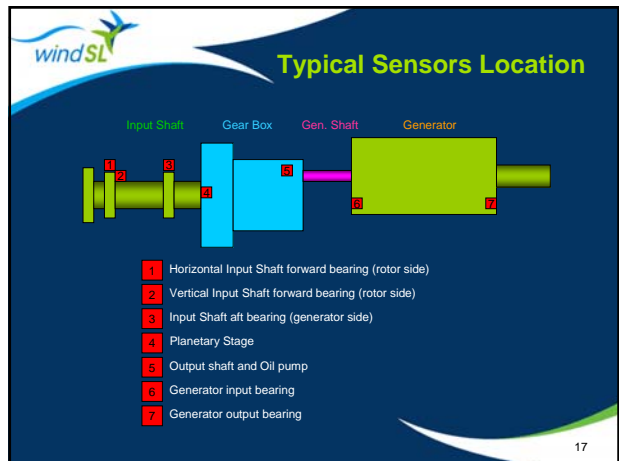



D&P General Approach

- ❖ Current generation HUMS / D&P systems use faulty data recorded under several known defects
 - ❖ Result of seeded fault tests and actual faulty data.
 - ❖ Usually rare and expensive to get.
- ❖ WindSL technique is based on the alternative approach of normal system behavior characterization.
 - ❖ Available.
 - ❖ Can be well characterized.
 - ❖ Connects between Diagnostic Features and Contextual Variables.
 - ❖ "Normal behavior" deviations considered a "novelty" (mostly caused by an appearing defect that eventually becomes a failure).

22

windSL
reliable wind energy

HUMS

Health and Usage Monitoring/Management System

Diagnostics & Prognostics (D&P)

21

Contextual Variable used for D&P

Helicopters	UAVs	Wind Turbines
Ambient temperature	Ambient temperature	Ambient temperature
Shaft speeds	Shaft speeds	Shaft speeds
Ambient pressure	Barometric altitude	Wind speed
Longitude/Lateral air speed	Calibrated airspeed	Pitch position
Longitude/Lateral accel.	Fuel weight	Turbine state
Weight on wheels	Weight on wheels	
Engine torques	Engine throttle command	
Gearbox oil temperatures	Water level	
Pitch/Roll/Heading	Pitch/Roll/Heading	
Collective command	Pitch/Roll/Yaw Rate	
Pedal command	Engine air temperature	
Engine parameters	Cooling water temperature	
Radar altitude	RMS of igniter current	

24

Health Levels

- Green**
 - No abnormality identified
- Yellow**
 - Deterioration level and rate are continuously trended
 - Deterioration still at a "Defect" level
 - Future maintenance activity can be planned
- Red**
 - Deterioration reached a level where a maintenance activity should take place no later than several weeks from alert in accordance with WT operator convenience
 - Damage severity continues to be monitored in real-time

23

Diagnostic Features Extraction

- ❖ Diagnostic features are produced using all relevant signals that are being tested continuously, taking into account several Digital Signal Processing procedures:
 - ❖ Simple time domain characteristics such as simple statistical moments.
 - ❖ FFT-based techniques are used to produce frequency domain features.
 - ❖ Modulated signals are analyzed using complex envelop techniques.
 - ❖ Complex cases require the use of a dual time-frequency analysis, such as Wavelet Transform.

26

Component name

#	Component name
1	Main Shaft Rotor Side Roller Bearing
2	Main Shaft Generator Side Roller Bearing
3	Main Shaft
4	Carrier Rotor Side Bearing
5	Carrier Generator Side Roller Bearing
6	Planet Roller Bearing
7	Low Speed Shaft Rotor Side Roller Bearing
8	Low Speed Shaft Generator Side Roller Bearing
9	Low Speed Shaft Generator Side Ball Bearing
10	Intermediate Speed Shaft Rotor Side Roller Bearing
11	Intermediate Speed Shaft Generator Side Roller Bearing
12	Intermediate Speed Shaft Generator Side Ball Bearing
13	High Speed Shaft Rotor Side Roller Bearing
14	High Speed Shaft Generator Side Roller Bearing
15	Planetary Gear
16	Intermediate Gear
17	High Speed Gear
18	Low Speed Shaft
19	Intermediate Shaft
20	High Speed Shaft
21	Generator Shaft Rotor Side Ball Bearing
22	Generator Shaft Generator Side Ball Bearing
23	Generator Shaft

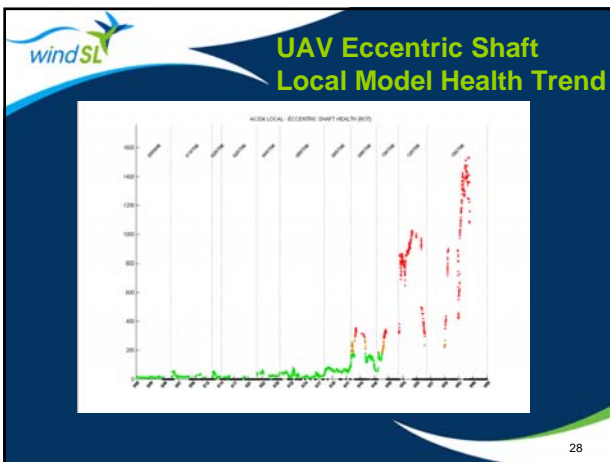

Prognostics Self-Learning Algorithm

- ❖ The Self-Learning Algorithm builds a **Local Model** which can estimate all diagnostic features using contextual variables.
- ❖ Self-Learning Algorithm compensates for most of the diagnostic features variability during usage, and by doing so, it enables prognosis at early faulty stages.
- ❖ **Local Model** - representing a specific serial number and requires retraining of the model after every significant maintenance operation.
- ❖ **Global Model** - is constructed using large amount of historical "normal data", from all machines.

27

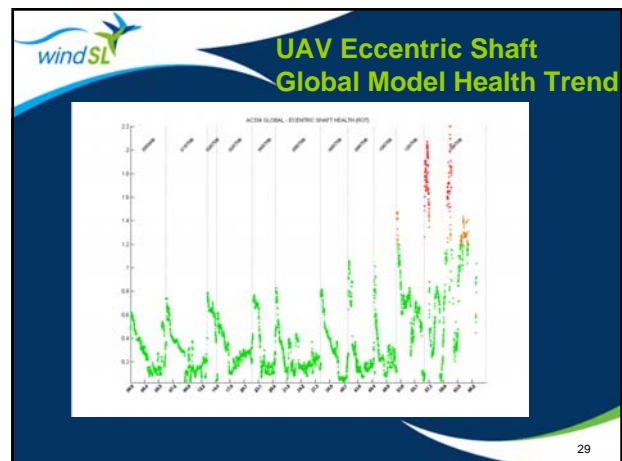
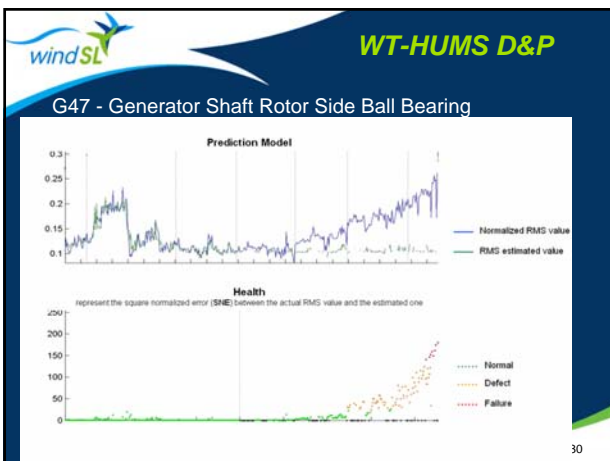

Generator Bearings Sensors Location

Generator Output Bearing Sensor

Generator Input Bearing Sensor

32

Proven performances

March 16, 2008 G47
Generator Shaft Rotor Side Ball Bearing

Health Deterioration Level [%]

Oct 15, 2007 - First Red alert
Jan 7, 2008 - Verification by WT maintenance team
Apr 1, 2008 - Late bearing replacement because of lack of spares

31

Too early replacement

Internal

External

Defect level when replaced was only 42%

Maintenance action indicator

34

Bearing replacement

Internal

External

Defect level when replaced was only 80%

Maintenance action indicator

33

RHMC Remote Health Management Center

- ❖ Wind farms fleet management system
- ❖ Independent work station
- ❖ Located at the wind farm control room and/or wind farm owner headquarters' network
- ❖ Turbine alerts using LAN or Cellular transmission.
- ❖ Health alerts from each WT
- ❖ Wind Farm Reports

36

windSL
reliable wind energy

HUMS Health and Usage Monitoring/Management System

Remote Health Monitoring/Management Center (RHMC)

35

System Architecture

RMMC Screenshot – Wind Farms Overview

Health Management menu
Turbine icons

38

System Architecture

RMMC Screenshot – Homepage

Health management menu
Module for system administrator only: Users, Groups, permissions, System Tables, Data history
Logged in user information: Favorites, Helpdesk contact, online user manual
Click here to WTs Overview
All owners' wind farms health status distribution
Message board: For new data arrival and administrator
Health alert for a specific WT Component: Alert - failure, maintenance action needed - Failure - Defect - Future maintenance activity can be planned.
Wind farm health status distribution

37

System Architecture

RMMC Screenshot – WT Component Main Page

Health Status table
Health Rating table

40

System Architecture

RMMC Screenshot – WT Main Page

Parts Alert: Click to view Parts Page
WT Parts Status
enlarged WT components status spider graph. Each node represents the component health status (0 means failure)
The component health score

Hvordan redusere vedlikeholdskostnaden?

- Utvikle optimale vedlikeholdsstrategier for planlagt og ikke-planlagt vedlikehold som tar hensyn til adkomstrestriksjoner
- Utvikle adkomstmetoder som er mindre følsomme for vind/bølge-påkjenninger
- Redusere nødvendig tid til vedlikehold offshore
- Designe for bedre pålitelighet
 - Redusere antall komponenter og forenkle design
 - Modularisert design
 - Bruke høy-pålitelighets komponenter
 - Utvikle kostnadseffektiv korrosjonsbeskyttelse
 - Implementere kostnadseffektive tilstandskontroll- og fjernstyringssystemer



Vindkraft FOU-seminar, 22-23 januar 2009

SINTEF Energy Research

Hvor skal større vedlikehold utføres?

- Vindparken (eneste mulighet for bunnfaste)
- Tauing til "docking-stasjon" i vindparken
- Tauing til havn
- Kombinasjon (mindre vs. større vedlikehold)



Vindkraft FOU-seminar, 22-23 januar 2009

SINTEF Energy Research

Tilstandskontroll

- Tilstandskontroll er og blir viktig for å oppnå kostnadseffektive drifts- og vedlikeholdsstrategier
- Predictive / "Just in time" maintenance
→ Gjør de rette tingene på rett sted til rett tid
- Mange ulike måleteknikker kan benyttes på de ulike komponentene, samt trending, diagnose/analyse og utnyttelse av data fra SCADA

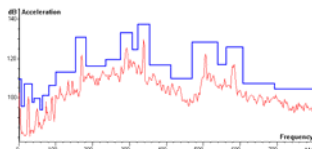

Vindkraft FOU-seminar, 22-23 januar 2009

SINTEF Energy Research

Adkomst

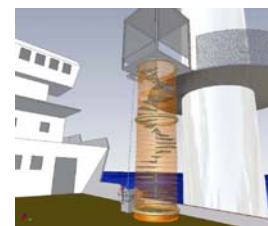
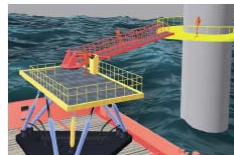

Logistikk

- Havner
- Fartøyflåte
- Reservedeler/depot
- Innkvartering av mannskap
- Hvor vedlikeholdet utføres har naturligvis stor betydning



Vindkraft FOU-seminar, 22-23 januar 2009

SINTEF Energy Research

Show-stopper?

- Ikke nødvendigvis, men krever nye løsninger:
 - Design for vedlikeholdsvennlighet (vedlikeholdsfritt?)
 - "Vedlikeholdsfri" maling/beskyttelse av tårnet
 - Smarte vedlikeholdsstrategier, med stor grad av fjernstyrte og automatiserte operasjoner
 - Online tilstandskontroll og diagnose
 - Lavkost vedlikehold
 - Prediktivt (just in time) og mulighetsbasert vedlikehold



Vindkraft FOU-seminar, 22-23 januar 2009



Kostnadseffektiv D&V er en av flere store utfordringer som må løses på veien mot lønnsom energiproduksjon fra havbaserte vindkraftanlegg, med tilhørende kjempepotensial for norsk leverandørindustri

→ *D&V blir en viktig del av kommende FME*



Bøyeteknologi for måling av vind, bølger og strøm

Jan-Petter Mathisen
Fugro OCEANOR

www.fugro.com



Oversikt over presentasjon

- Historikk
- SEAWATCH systemet
- Bøyekonsept
- Anvendelser
- Bøyekonsept for vindmøller
- Karlegging av energipotensial

www.fugro.com



Historikk

- 1985: Behov for sanntidsmålinger i forbindelse med Troll utbyggingen og utvikling av Tobis bøya
- 1983-1985: Utvikling av Wavescan bøya
- 1985: WADIC eksperimentet hvor de fleste kommersielle bøyeprodusenter deltok
- 1988-1995: SEAWATCH Europe hvor SEAWATCH bøya ble utviklet til en multisensor bøye
- 1995: MRU bølgensensor introdusert av Seatex
- 2004: WaveSense lavenergi bølgensensor introdusert av Oceanor
- 2006: Tsunami varslingsbøyer plassert i Malaysia

www.fugro.com



TOBIS buoy

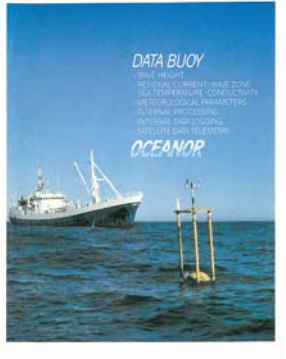

www.fugro.com

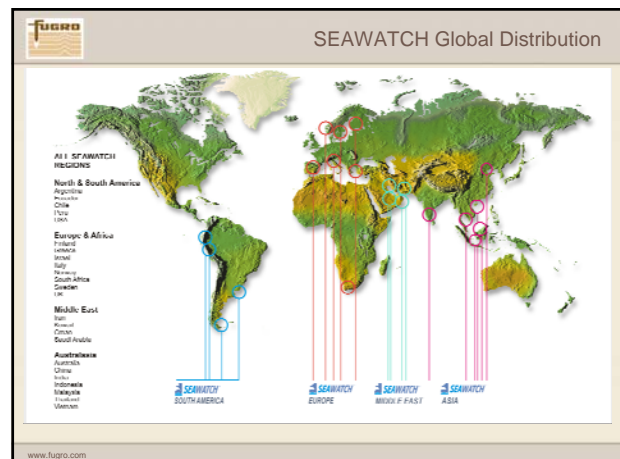
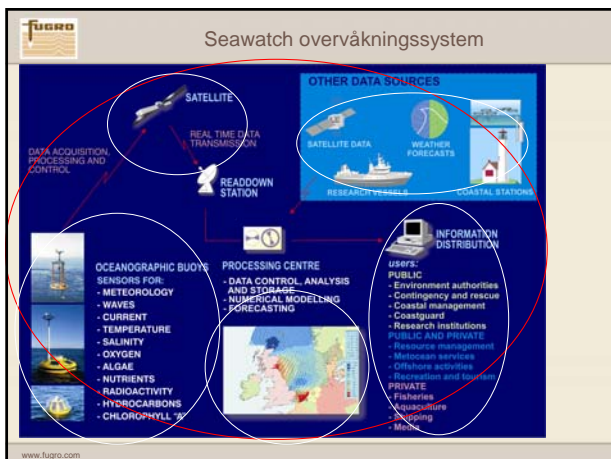

OCEANOR's Metocean buoys

www.fugro.com

WIND SENSORS

Cup & vane type wind sensor (RM Young)

Ultrasonic sensors (low maintenance) (RM Young)

www.fugro.com

Fugro OCEANOR. Measurement equipment

OCEANOR develops/designs, produces, implements and operates environment monitoring systems

- Seawatch/ Wavescan buoys
- Riverwatch stations
- Soilwatch stations
- Met stations
- Water quality sensors
- Wavesence
- CCTV

www.fugro.com

Brukere

www.fugro.com

The Seawatch Tsunami Module

Integrated in the SEAWATCH system
According to IOC/WMO recommendations

www.fugro.com

Oceanographic measurements

www.fugro.com

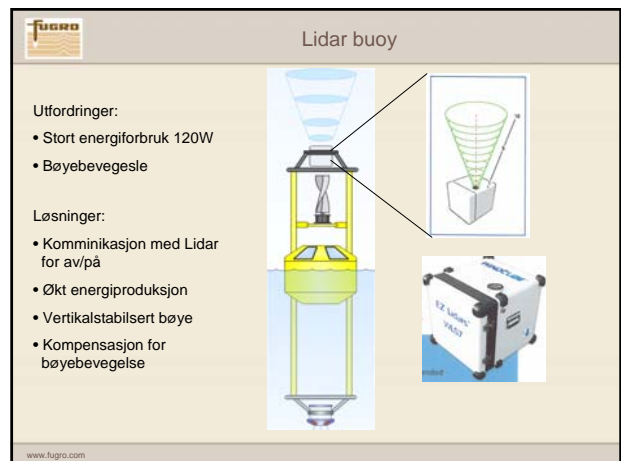
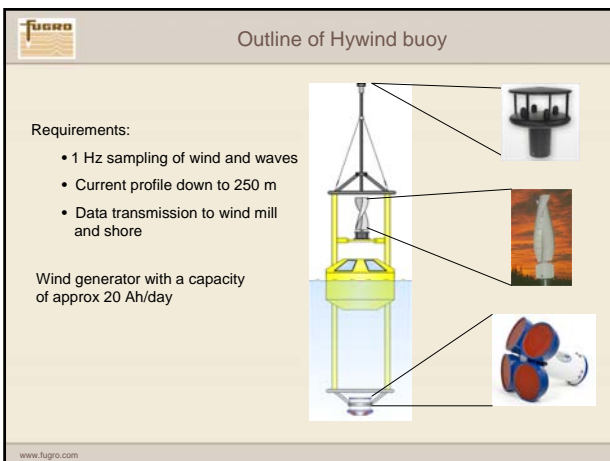
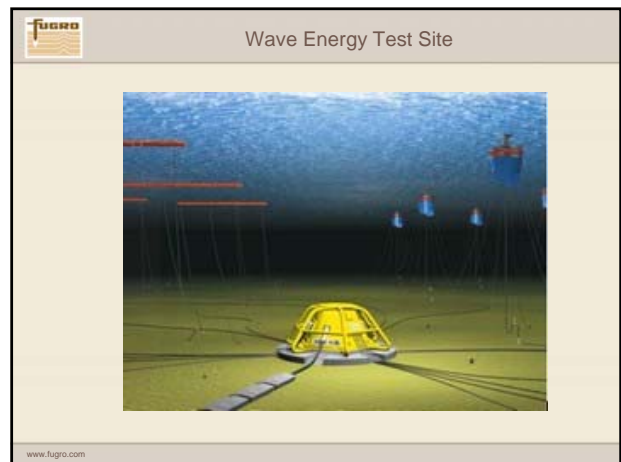
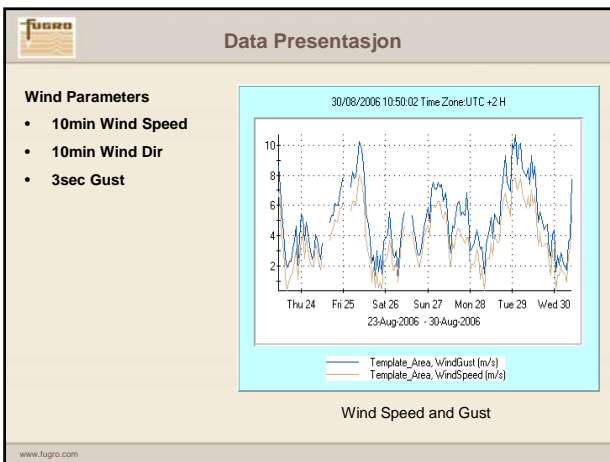
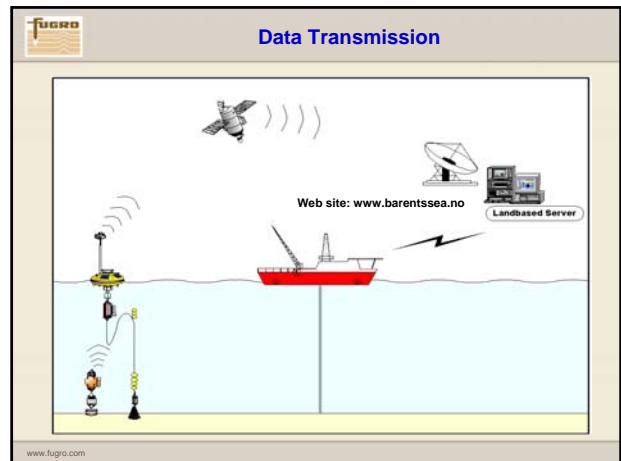
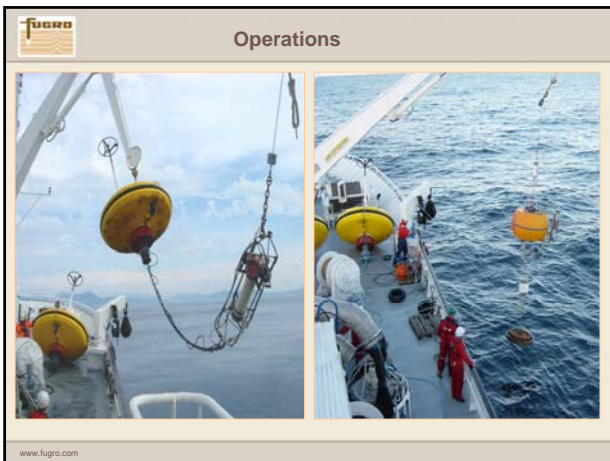

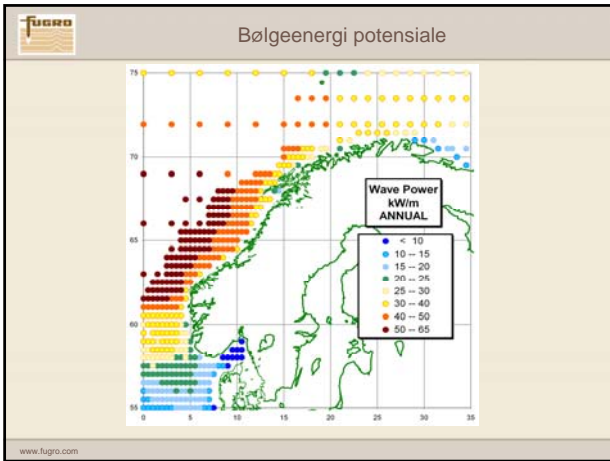

Eksperimenter og demonstrasjon

Hydraulisk gir for vindturbiner, Svein Kjetil Haugset, ChapDrive

Mekanisk drivlinje med eksentergir og vertikal aksel mellom rotor og generator i bunnen av tårnstruktur, Lars Raunholt, AngleWind

Ny generatorteknologi for vindkraftverk, Sigurd Øvrebø, Smartmotor

Testområde Stadt, Edgar Kvernevik, Senior Rådgjevar, Vestavind

OWEC Tower sitt forskningsprogram ved testfeltet Alpha Ventus, Sveinung Nesheim, OWEC Tower AS

WindSea - 3 turbiner - 1 plattform, Marc Lefranc, WindSea

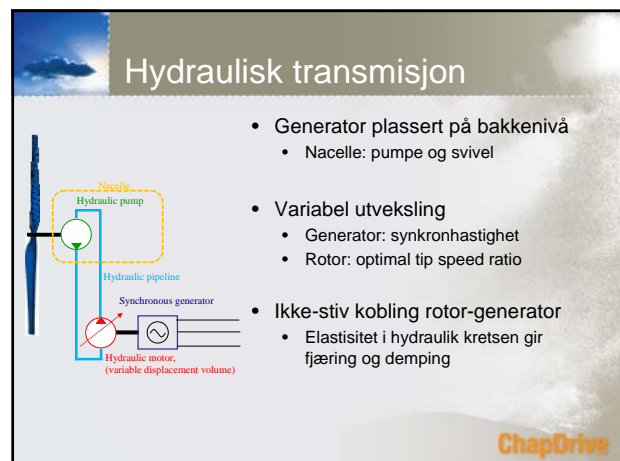

Aktiviteter 2008

Testdrift ChapDrive 1: V27/225kW

- Turbinen ferdigbygd våren 2008
- Testkjøring
 - Oppstart ↔ utbedring av design
- Effektmålinger
 - Målinger iht. IEC 64100-12
 - **Resultat er i tråd med forventning**
 - Måleresultat utløste 2. emisjon



Aktiviteter 2008

Bygger ChapDrive 2: NM900/52

- Design og installasjon nacelle
- Installasjon av tårn, nacelle og rotor på Valsnes
- "Power-unit" er under bygging
 - Motor, generator og styresystem
- Ferdigstilling og testdrift i løpet av våren



Aktiviteter 2009

- ChapDrive 1:
 - Optimalisere designet
 - Utvikle autonomt kontrollsystem
- ChapDrive 2:
 - Testkjøring og virkningsgradmåling
 - Utvikle autonomt kontrollsystem
- Utvikle simuleringsverktøy
 - Integre modell av hydraulisk gir i aeroelastisk beregningsverktøy



ChapDrive 3: 5 MW

- Ser på løsninger for en 5 MW turbin
 - ChapDrive må tilby gir i MW-klassen
 - Kun på planleggingsstadiet
 - Overslag over effekt produksjon
 - Kravspesifikasjon for komponenter
 - Diskusjon med mulige leverandører



 Vindkraft FoU Seminar, January 2009

"Mechanical Drive Train with Eccentric Gearbox and Generator located at Ground Level"

by Lars Raunholt, CEO



1

 Focus on technology development

- Patentable eccentric gearbox with approx. 1:20 ratio
- Corresponding transmission system for locating generator at ground level
- Robust and simple gearbox with integrated bearings and overload protection
- Substantial reduced weight of nacelle
- Reduced O&M cost with generator and trafo at ground level



2

 Two alternatives for commercialization

- Supplier of new type of innovative gearbox
 - For conventional multi-MW market
- Development of new drive train system with generator located at ground level
 - For emerging Norwegian offshore market

3

 Owners and Board

- Owners:
 - SäkorninVest II AS, 40 %
 - Founders, 60 %
 - (Energy company Lyse has certain rights through industrial co-operation)
- Board of Directors:
 - Tor Albert Ersdal, Chairman
 - Jonas S. Sandved, Per Olav Haugom, Lars Raunholt and Stig Svalheim
- Company start-up December 2007

4

 The organization

- Management:
 - Lars Raunholt (part-time)
 - Per Olav Haugom AS (part-time consultant)
 - Senior Mechanical Engineer
 - Looking to recruit "CTO" before Summer 2009
 - (2 more key employees needed within 2009)
 - Support from Lyse
- Suppliers / Consultants:
 - Det norske Veritas (verification of calculations)
 - Use of engineering consultants
 - Strategic relationship with suppliers

5

 SäkorninVest II AS: Focus on early stage investment in the Energy Sector

THE FUND	THE TEAM
<p>Management Company</p> <ul style="list-style-type: none"> • SäkorninVest Management AS • 2 funds under management: Säkorn I and II • Total size: 400 MNOK • Seed & early-stage investment targets only <p>Säkorn I</p> <ul style="list-style-type: none"> • Fully invested: Energy, Life Science, ICT • One listed company, 4 in growth mode <p>Säkorn II</p> <ul style="list-style-type: none"> • Closed October 2006 • Investors: Oil & Gas, Utilities, Banks, HNWI's • Focus on Energy, will also invest in Life Science and ICT • Four investments to date, several in works 	<p>Jonas Schanche-Sandved, Partner</p> <ul style="list-style-type: none"> • Civ. Eng., Newcastle upon Tyne • 22y Statoil, Ind'n & Commercialization • 7y Det norske Veritas <p>Tor Albert Ersdal, Partner</p> <ul style="list-style-type: none"> • MSc, BSc, Economics, U. of Oslo • 5y investment management • 2y Financial analyst, Finance journalist <p>Siljan Vemmedstad, Partner</p> <ul style="list-style-type: none"> • MBE, BI Sandvika • 4y CFO, Alliance ASA and Sage Oil ASA • 5y General Manager in Alliance provider ASA

 6

Energy company partner Lyse

- Energy company in Rogaland County (Stavanger)
- Planned wind projects:
 - Ulvarudla, 231 MW land
 - Brusali-Karten, 120 MW land
 - Utsira, 280 MW deep offshore
 - South North-sea, 1000 MW, offshore



7

Phased technical development with clear milestones, gearbox

- Concept phase
 - Concept drawings, patenting, freedom-to-operate, animations
 - 3. party concept evaluation, Det norske Veritas
 - Supported by Innovation Norway, finalized
- Development phase and scale test (225 kW)
 - Design of gearbox, bearings, balancing, overload solution and angle arrangement
 - Workshop and 3. party test of 225 kW eccentric gearbox
 - Fully financed, 6 MNOK, Started May 2008, 12 month project
- Development and test of multi-MW gearbox (3 MW)
 - From 2009, 12 MNOK budget, 8 MNOK already in LoI from investors, rest from government R&D funds

8

Prototype development, gearbox

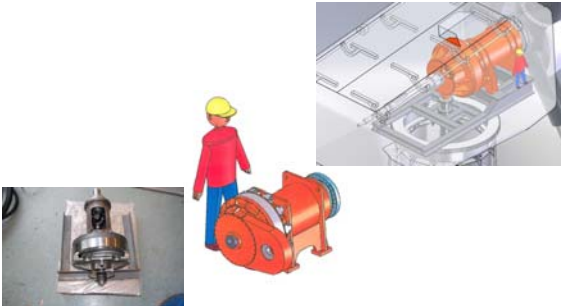

Small model 225 kW Multi-MW (3 MW)

9

Animation of eccentric gearbox principle



10

Development of "angle" concept with generator at ground level

- Development phase and scale test (225 kW)
 - Design of angle arrangement
 - Workshop and field test in Rogaland, Norway of 225 kW arrangement in second-hand wind turbine
 - Looking at five different sites
 - Co-operation with DnV for approval of prototype
 - Budget 3-4 MNOK
 - Installation ultimo 2009



11

Development of "angle" concept, Multi-MW Offshore

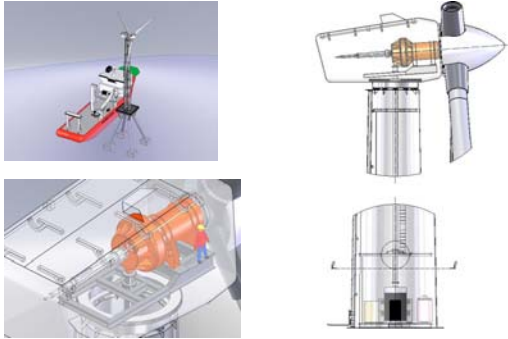

12





FoU Vind Seminar, Trondheim 23.01.09

SmartMotor
Energy Efficient Technology

SmartMotor

Turnover/Result:

Facts:

- 28 employees
- Patented State of the art technology
- Strong technical team
- Strong profitable growth
- Strong group of owners
- Solid customers

SmartMotor
Energy Efficient Technology

Markets/Products

Renewable Energy

Marine

Oil/gas

<input type="checkbox"/> Low-speed generators	<input type="checkbox"/> Propulsion machines	<input type="checkbox"/> High-tv/pressure systems
<input type="checkbox"/> Integrated electronics	<input type="checkbox"/> High-torque winches	<input type="checkbox"/> Motors and actuators
<input type="checkbox"/> Grid interface	<input type="checkbox"/> Intelligent valves	<input type="checkbox"/> Power and control electronics
<input type="checkbox"/> Submerged systems	<input type="checkbox"/> Pressure-compensated systems	<input type="checkbox"/> Contact-less power transfer

SmartMotor
Energy Efficient Technology

SmartMotor Scope: From Shaft To Grid

Main parts in SmartMotor's scope:

- Generator- tailored
- Converter
- Transformer
- Switchgear

Customer provide strong point on:

- Tower
- Turbine
- Blades
- Production
- Installation
- Marked

We believe that the next generation of wind turbines will come as results of close cooperation between turbine and generator designers

SmartMotor
Energy Efficient Technology

Research programs

"PM-Innovation" 2005-2009
 Participants: NFR, RolceRoyceMarine, SmartMotor
 Size: 16,7 MNOK
 Focus: Ironless Permanent Magnet Machines

"Weigth reduced wind power systems" 2005-2009
 Participants: EBL, Lyse, Statkraft, NVE, Shell, Wartsila, SmartGenerator, SmartMotor
 Size: 20 MNOK
 Focus: System design

SmartMotor
Energy Efficient Technology

FoU in SmartMotor

- System Optimization
- Electric machines
- Drives and Controls
- High Voltage insulation systems
- Composites
- Lifetime

SmartMotor
Energy Efficient Technology

Ironless generators - Demos

PM-Innovation: Funded by NFR, RRM, SM
Two demos
-AX50
-AXM1
Program closing in 2009



SmartMotor
Energy Efficient Technology

Radial flux PMSM - Demos

Investigated for Wind power at NTNU
Proven in harsh environments in Marine market
Full scale pilot in design phase



SmartMotor
Energy Efficient Technology

Integrated direct driven RF-PMSM design

Rotor diameter and weights of large wind turbines

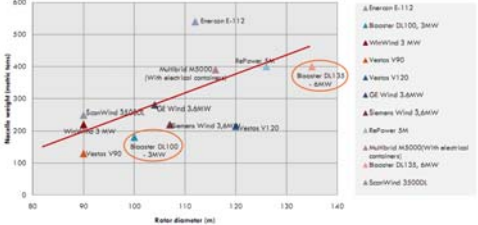



Legend:

- ▲ Enercon E-112
- ▲ Bosner DL100, 3MW
- ▲ WinWind 3 MW
- ▲ Vestas V90
- ▲ Vestas V120
- ▲ GE Wind 3.6MW
- ▲ Siemens Wind 3.6MW
- ▲ Siemens Wind 3.6MW
- ▲ Vestas V120
- ▲ Enercon E-112
- ▲ Bosner DL100, 3MW
- ▲ WinWind 3 MW
- ▲ Vestas V90
- ▲ Vestas V120
- ▲ GE Wind 3.6MW
- ▲ Siemens Wind 3.6MW
- ▲ Siemens Wind 3.6MW
- ▲ Vestas V120
- ▲ Enercon E-112
- ▲ Bosner DL100, 3MW
- ▲ WinWind 3 MW
- ▲ Vestas V90
- ▲ Vestas V120
- ▲ GE Wind 3.6MW
- ▲ Siemens Wind 3.6MW
- ▲ Siemens Wind 3.6MW
- ▲ Vestas V120

SmartMotor
Energy Efficient Technology

Tailored Generators for Wind Power

Permanent Magnet Synchronous Machines
Radial flux Permanent Magnet Machines
Direct driven - MW
690 V or 3,3 kV
Axial flux Ironless Permanent Magnet Machines
Direct driven - MW
3,3 or 6,6 kV

SmartMotor
Energy Efficient Technology

Thank you for your attention



Contact information:
SmartMotor, Jarleveien 8, Trondheim, Norway
Telephone: +47 73 98 25 00
E-mail: mail@smartmotor.no



Testområde Stadt

Testområde for flytande vindturbinkonsept

Edgar Kvernevik Siv.ing. Marin Teknologi/Offshore
Senior Rådgjevar/Prosjektleiar Vestavind Kraft AS



Vestavind Kraft AS

Formål: Utvikle, eige og drive vindparker på land og til havs.

Hovudkontor: Sandane i Nordfjord



- På lag med lokalsamfunnet

Hovudkontor, Sandane

Vestavind Kraft AS

Partners: SFE, SUNNFJORD ENERGY AS, Sognekraft, BRCK, SUNNFJORD KRAFTLAG, VINDKRAFT



Våre prosjekt i forskjellige utviklingsstadier

- Konesjon under behandling
- Meldt
- Under utvikling

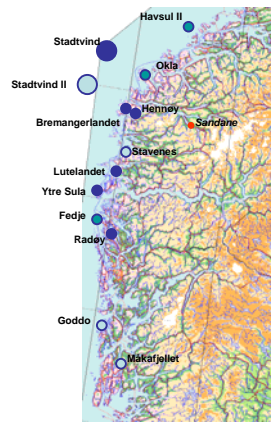

Locations: Havsul II, Stadtvind, Stadtvind II, Okla, Bremangerlandet, Henøy, Sandane, Stavenes, Lutelandet, Ytre Sula, Fedje, Radey, Goddo, Måkfjellet



Prosjekt oversikt VK

Prosjekt	Kommune	Total installasjon [MW]	Årlig produksjon [GWh]	Status
Totalt		2 463	8 617	
Stadtvind	Selje/Vågsøy	1 080	4 500	Meldt
Havsul II	Haram/Giske	(400)800	2 400	Konesjon avsl./anka
Bremangerlandet	Bremanger	160	500	Konesjonssøkt
Ytre Sula	Solund	150	450	Meldt
Goddo	Bømlo	70	190	Under arbeid
Lutelandet	Fjaler	50	150	Meldt
Henøy	Bremanger	40	120	Meldt
Radey	Radey	40	100	Meldt
Staveneset	Askvoll	35	100	Under arbeid
Måkfjellet	Vindafjord	30	80	Under arbeid
Okla	Selje	21	65	Konesjonssøkt
Fedje	Fedje	8	25	Konesjonssøkt

Vindparker i drift 2009-412MW(kjelde NVE.no)



Idriftsatt

No	NAVN	TILTAKSHAVER	FYLKE	KOMMUNE	MW
1	BESSHØFFJELLET	TRONDENERGI KRAFT AS	SØR-TRONDELAG	ROAN	27,6
2	FELLSØRÅ	AGDER ENERGI PRODUKSJON AS	VEST-AGDER	LINDESNES	4
3	GARTFJELLET	KJØLEF JORD VIND AS	FJØRMARK	LESEBY	40
4	HARDY	SANDVY VINDKRAFT A/S	NØRRE OG RØMSDAL	SANDVY	3,75
5	HAVDYGAUEN	ARCTIC WIND AS	FJØRMARK	HÅGGDY	40
6	HETRA (ELDØFJELLET)	HETRA VIND AS	SØR-TRONDELAG	HETRA	55
7	HUNDHAMREFFJELLET-1	NORD-TRONDELAG ELEKTRISITETSVIRK FKF	NORD-TRONDELAG	NØRØY	2
8	HUNDHAMREFFJELLET-2	NORD-TRONDELAG ELEKTRISITETSVIRK FKF	NORD-TRONDELAG	NØRØY	3
9	HUNDHAMREFFJELLET-3	NORD-TRONDELAG ELEKTRISITETSVIRK FKF	NORD-TRONDELAG	NØRØY	51
10	HEHØKEN I	KVALHEIM KRAFT AS	SØGN OG FJØRDALE	VÆGGDY	4,25
11	NYGÅRDFJELLET	NARVIK ENERGI AS	NORLAND	NARVIK	7
12	SANDHAUGEN	NORSK MILJØKRAFT FOU AS	TROMS	TROMSØ	8
13	SMOLA	STATKRAFT ENERGI AS	NØRRE OG RØMSDAL	SMOLA	150
14	UTSRNA VIND- OG HYDROENERGI	NORSK HYDRO PRODUKSJON AS	ROGALAND	UTSRNA	1,3
15	VALDRESET	TRONDENERGI KRAFT AS	SØR-TRONDELAG	ØYUN	9,2
16	VALDRESET TESTSTASJON	VIVA AS	SØR-TRONDELAG	ØYUN	2,35
17	VINNA HØFJELLET	NORD-TRONDELAG ELEKTRISITETSVIRK FKF	NORD-TRONDELAG	VINNA	2,2

Bakgrunn



- Vestavind Kraft AS melder 23/10-2007 ein offshore vindpark STADTVIND (1080MW) basert på flytande vindturbinar utanfor Stadlandet i Sogn og Fjordane
- For å realisere Stadtvind og andre tilsvarende norske offshore-prosjekt må utviklinga av flytande turbinkonsept drivast framover på fleire frontar i eit nasjonalt samarbeid.
- Finansiering krev dokumenterte eigenskapar på vindturbinane

Kva krevst for å drive utviklinga framover



- Parallell uttesting av ulike konsept for å akkumulere testtid og erfaringar raskast mogleg
- Dokumentasjon av eigenskapar over tid i aktuelle områder med relevante vind og bølgef forhold.
- Samarbeid med Klaseselskap, eks.DnV.
- *Tankefors:* 10-20 års utviklingsperspektiv for flytande vindturbinar. Dette er for langsamt.

Krav til Testområde



- Rikelig med vind og bølger
- Posisjonar med ulik eksponering for bølger og vind
- Passande djupne
- Passande botn
- Rask tilkomst
- Nærliggande infrastruktur for støttefunksjonar

Testområde Stadt



Plassering i forhold til Stadtvind havmøllepark

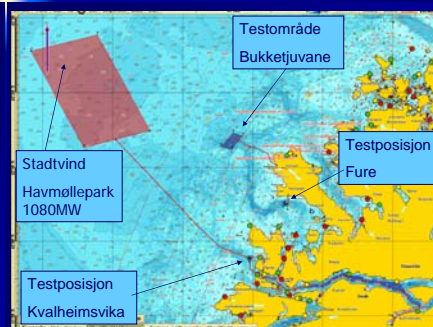

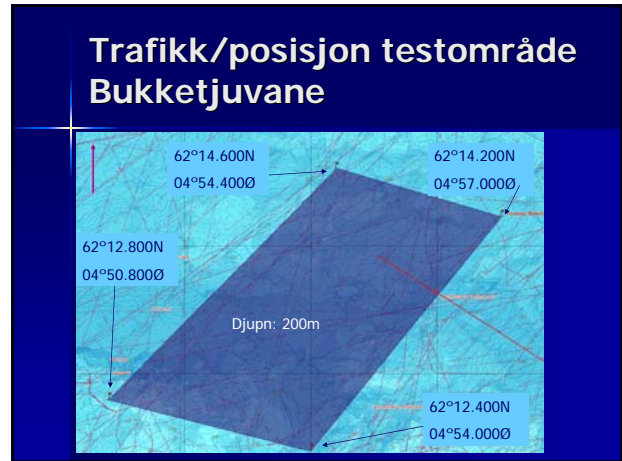
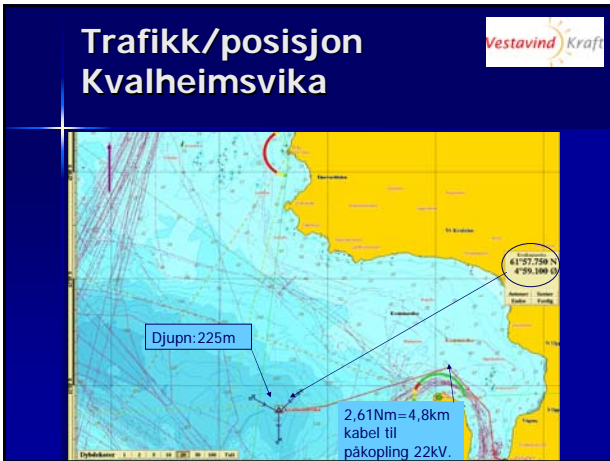
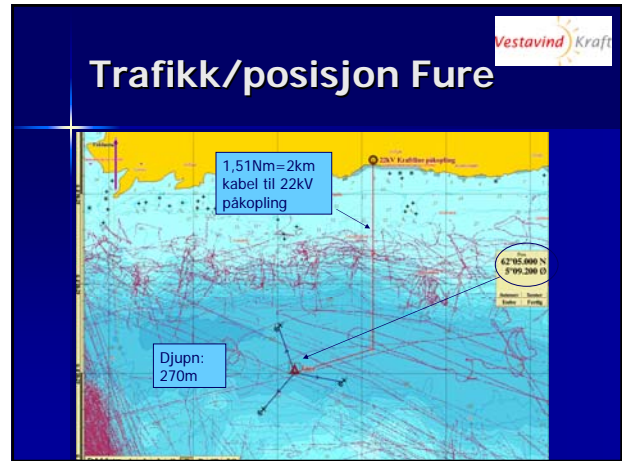



Tilknytning til Nett

- Krev konsesjon frå NVE
- Nettet i området er modellert inklusive aktuelle vindparker i området: Mehuken II og Okla.
- Lastflytanalyse er utført
- Dynamisk analyse under arbeid
- Analysane viser at tilknytning kan skje i eksisterande nett med enkle tilpassingar.

Status

- Konsesjonssøknad sendt NVE Desember 2008
- Høyringsrunde mot fiskarlag, Nordfjord Hamn, Kystverket, Selje og Vågsøy kommunar utført.
- Dispensasjon frå kystsoneplan er søkt for testposisjon Fure og Kvalheim som ligg innanfor grunnlina.
- Testområde Bukketjuvane ligg mellom 4 og 6Nm frå grunnlina.

Føresetnader for områda/posisjonane

- Etter testperioden skal alle installasjonar fjernast
- Ingen restriksjonar knytta til fiskeri i områda, kun eventuelt trålforbod i kabeltraseen og over ankerliner.
- Merking av utplasserte turbinar i samsvar med krav frå kystverket og luftfartstilsynet i tillegg til AIS merking.
- Forankring i samsvar med krav frå Det norske Veritas, Kystverket og Nordfjord Hamn.

Oppsummering testområde Stadt

- Landets mest vind og bølgeutsette område.
- Kort avstand til støttefunksjonar som verft og servicefartøy
- Nær Stadtvind, noko som gjev relevante testresultat mhp. vind og bølger
- Sterkt og konkurransedyktig skips og marinteknisk fagmiljø med relevant kompetanse.



OWEC Tower sitt forskningsprogram ved testfeltet Alpha Ventus

OWEC Tower sitt forskningsprogram ved testfeltet Alpha Ventus

1



OWEC Tower

Research at Alpha Ventus

OWEC Tower sitt forskningsprogram ved testfeltet Alpha Ventus

OWEC Tower sitt forskningsprogram ved testfeltet Alpha Ventus

2



PRODUKT

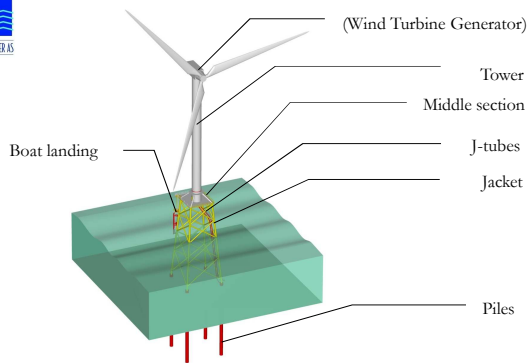

OWEC Tower sitt forskningsprogram ved testfeltet Alpha Ventus

3



PRODUKT

- Tilpassa vandndjup fra 15m til 100m
- Basert på kvalifisert teknologi
- Innovative detaljer skaper forsprang
- Effektiv lastoverføring fra tårn til jacket
- Gunstig stivhet og egenfrekvens
- Meget konkurransedyktig over 20m
- Fabrikasjonsvennlig
- Installasjonsvennlig

OWEC Tower sitt forskningsprogram ved testfeltet Alpha Ventus

4



OM SELSKAPET

- 30 års erfaring frå petroleumsindustri
- Fundament for offshore WTG sidan 2001
- Seks tilsette, pluss normalt ein konsulent
- Eigarskap
 - NorWind største eiger
 - Scatec
 - Grieg
- Enkelt-aksjonærer

OWEC Tower sitt forskningsprogram ved testfeltet Alpha Ventus

5



SENTRALE PARTNERE

- Burnt Island Fabrication Ltd (BiFab)
 - Fabrikasjon
- NorWind
 - Installasjon
- Teknisk Data AS
 - Analyse og verifisering
- Semar
 - Teknisk tegning
- NGI
 - Peleberegning og grunnforholdsanalyse
- NTNU
 - Teknisk veiledning

OWEC Tower sitt forskningsprogram ved testfeltet Alpha Ventus

6

 **FABRIKASJON**



- Verftskapasitet
- Skottland: 50 enheter per år
- Tyskland: 100 enheter per år fra 2010

OWEC Tower sitt forskningsprogram ved testfeltet Alpha Ventus

7

 **BEATRICE**



OWEC Tower sitt forskningsprogram ved testfeltet Alpha Ventus

8

 **OWEC Tower**

Research at Alpha Ventus

OWEC Tower sitt forskningsprogram ved testfeltet Alpha Ventus

OWEC Tower sitt forskningsprogram ved testfeltet Alpha Ventus

9

 **KONSEPT**

- Utviklere
 - EWE
 - E-ON Climate & Renewables
 - Vattenfall Europe New Energy
- 45 km nord for Borkum
- 30m vanddjup
- Seks tripod enheter med Multibrid M5000
- Seks enheter med Repower 5M

OWEC Tower sitt forskningsprogram ved testfeltet Alpha Ventus

10

 **ALPHA VENTUS**



OWEC Tower sitt forskningsprogram ved testfeltet Alpha Ventus

11

 **MÅL OG MIDLER**

- Målsetting
 - Bidrag til 20% fornybar energi innen 2020
 - Redusere kostnad ved utbygging av offshore vindkraft
- Midler
 - 50 millioner Euro over dei nærmeste år
 - Samarbeidsprosjekt
 - Universitet
 - Institutt
 - Andre sentrale forskningsorgan

OWEC Tower sitt forskningsprogram ved testfeltet Alpha Ventus

12



FORSKNINGSPROGRAM

- Fullskala målinger av knytoppunkter på tripod og jacket
- Analysering og modellering av laster ved offshore WTG
- Videreutvikling av LIDAR vindmåling
- Kabelnettverksstudier
- Overvåking og sensorering
- Måling av operasjonell støy og modellering av lydutvikling mellom installasjon og miljø
- Økologisk og geologisk forskning

OWEC Tower sitt forskningsprogram ved testfeltet Alpha Ventus

13



OWEC Tower

Research at Alpha Ventus

OWEC Tower sitt forskningsprogram ved testfeltet Alpha Ventus

OWEC Tower sitt forskningsprogram ved testfeltet Alpha Ventus

14



BAKGRUNN

- Samarbeid med NTNU og NGI BIP om forskningsprogram
- Forskningsrådet innvilger BIP søknad
- Tre års forskningsprogram ved OWEC Tower
- Bistand fra NTNU ved Postdoc stilling
- Øvrig finansiering fra eksterne interessenter

OWEC Tower sitt forskningsprogram ved testfeltet Alpha Ventus

15



FORSKNINGSPROGRAM

- Evaluering og implementering av målesensorer
- Registrere og prosessere miljølaster og strukturrepons
- Analysere korrelasjon mellom E- og P-data
- Dynamisk lastmatrise for ekvivalent miljølast
- Definere avvik mellom P-data og simulering
- Definere fenomeniske mekanismer
- Utvikling av simuleringsrutiner
- Ekstrapolering for levetidsanalyser

OWEC Tower sitt forskningsprogram ved testfeltet Alpha Ventus

16



MILJØDATA (E-DATA)

- Hydrodynamikk
 - Sjøtilstand og vannstand
 - Bølgekinetikk
 - Turbulens
- Havbunn
 - Suspensjon
 - Øvrige endringer i havbunn
- Vind
 - LIDAR

OWEC Tower sitt forskningsprogram ved testfeltet Alpha Ventus

17



RESPONS (P-DATA)

- Jacket
 - Spenning
 - Akselerasjon
 - Overlagringer og perioder
 - Fenomener
- Global
 - Relativ forflytning
 - Endring i forflytning

OWEC Tower sitt forskningsprogram ved testfeltet Alpha Ventus

18



KORRELASJON

- Tolke E- og P-data i forskjellige domener
 - Sammenhenger og mekanismer
 - Lineære
 - Ulineære og komplekse
 - Definere med hensyn til relevante størrelser og koplinger
 - Fysiske koplinger
 - Periode og fysiske størrelser
 - Spenninger og akselasjoner
- Hjelpemidler
 - Håndberegninger
 - FEM analyser
 - Artificial Neural Network

OWEC Tower sitt forskningsprogram ved testfeltet Alpha Ventus 19



EKVIVALENT MILJØLAST

- Bygge ekvivalent dynamisk vindlastmatrise ved hjelp av NREL FAST prosedyre
- Kontrollere pålitelighet sammen med REpower Systems
- Bygge algoritme for hydrodynamiske påkjenninger
- Importere til ANSYS ASAS

OWEC Tower sitt forskningsprogram ved testfeltet Alpha Ventus 20



SIMULERT RESPON

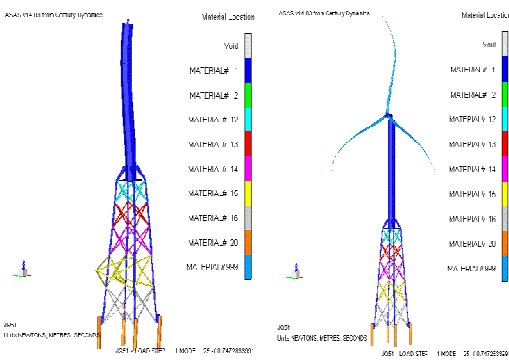

OWEC Tower sitt forskningsprogram ved testfeltet Alpha Ventus 21



SIMULERT RESPON

- 3D modellering
 - Stivhet i knytestrukturer
 - Sekundært stål
 - Fundamentering og peleanalyse
- Forbedre grid generering
- Simulere strukturrespons i ANSYS ASAS med ekvivalente miljølaste fra fullskalamåling
- Korrelasjon
- Freiste å definere årsaker til avvik
- Iterative rutiner for å forbedre simuleringer

OWEC Tower sitt forskningsprogram ved testfeltet Alpha Ventus 22



LEVETIDSANALYSE

- Metoder for ekstrapolering av operasjonelle belastninger
- Utmatningsanalyse
- Pålitelig tallfesting av levetid

OWEC Tower sitt forskningsprogram ved testfeltet Alpha Ventus 23



SPØRSMÅL



OWEC Tower sitt forskningsprogram ved testfeltet Alpha Ventus 24

WindSea



WindSea



FORCE Technology Norway AS utviklet WindSea konseptet frem til 2008.

WindSea AS ble etablert Juni 2008 og skal viderføre WindSea.

Eiere av **WindSea AS**:

- **Statkraft**
- **FORCE Technology Norway AS**
- **NLI AS**

Selskapene er ledende i sine teknologiske segmenter: Kraftproduksjon, hydro- og aerodynamikk, design av offshore konstruksjoner, fabrikasjon.

WindSea



Wind møller offshore hovedutfordringer:

- Konkurens med andre energikilder
- Høye kostnader for offshore arbeid
- Tilgjengelighet og atkomst

En offshore wind park må være enkle og billig å bygge, å installere, å vedlikeholde.

Hver enhet må ha høy produksjon.

WindSea



BAKGRUNN: Bruk av erfaring fra olievirksomhet.

Kostnadene er knyttet til:

- Installasjon
- Tilkost
- Vedlikehold
- Reparasjon

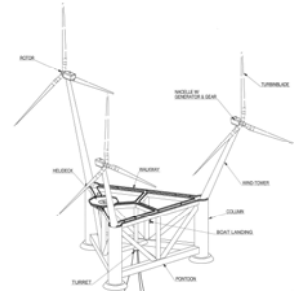

WindSea



Havet: Flytende konstruksjoner er lette å flytte

Hovedprinsipper:

- Bygge alt ferdig på verft
- Taue med ferdig monterte møller
- Preinstallere ankerlinjene
- Plattform orienteres mot vind
- Enkel sammenkobling med forankringsystemet
- Optimalisere energiproduksjonen

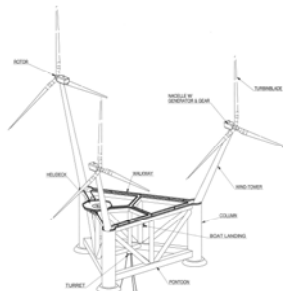

WindSea



LØSNING:

- Halvnedsenbar plattform
- Tre søyler
- Sentral kobling av ankerlinene i en "turret".
- Skråstilte tårn
- 3 turbiner: 2 upwind, 1 downwind

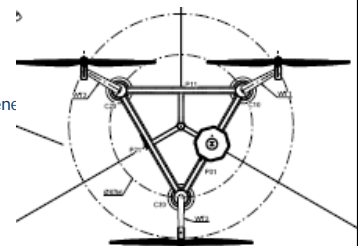

WindSea



FORDELER

- Stabil for stampe bevegelse
- Vind og bølge respons er uavhengige av hverandre
- God plass for atkomst
- Ingen begrensning for dekkslast
- God plass for vedlikehold
- Lett flyttbar til verft i tilfelle større reparasjoner
- Løftefartøy er unødvendige
- Høy tilgjengelighet
- Stiv Turbine-Tårn forbindelse
- Selvoriering mot vind

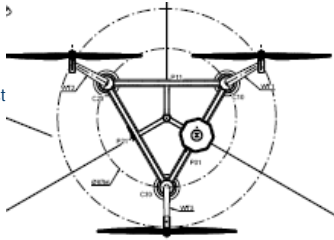

WindSea



WINDSEA AS er etablert for å videre utvikle konseptet.

Eiere:

- Statkraft
- FORCE Technology
- NLI

Validering phase er gjennomført.

Konsepts hovedprinsipper er bekreftet å være korrekte.
Total energi produsert for en gitt konfigurasjon er beregnet



WindSea



Vindtunnel test

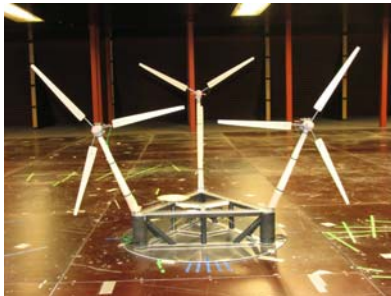

WindSea



Bølgebaseng test med vind



WindSea



Energiproduksjon

Tilgjengelighet: 85,2%

Total kraftproduksjon for WindSea : 30 GWh/år.
(Sørli Nordsjø vind data)

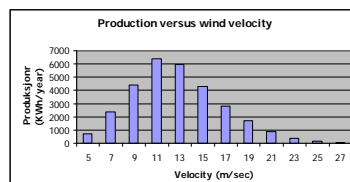

Som er 93% av det teoretiske maksimum for 3 turbiner alene :
32,1 GWh/år

Alle testene, beregningene bekrefter at konseptet er levedyktig

WindSea



Norsk innovativ offshore vindkraftteknologi

Norsk satsning på offshore vindkraft, Robin Martin Kåss, Statssekretær,
Olje- og energidepartementet

Offshore vind - en ny industri og et nytt marked for Aker Solutions,
Åge Tårnes, Aker Solutions

ScanWind status og veien videre, Kristian Holm, ScanWind

Offshore Vind - 2010-2020, Eystein Borgen, Adm. dir. SWAY

Status Hywind og vedlikeholds strategier for offshore vind, Elly Karlsen,
StatoilHydro

OLJE- OG ENERGIDEPARTEMENTET

Myndighetenes satsing på offshore vindkraft

Statssekretær Robin Martin Kåss
Olje- og energidepartementet

Vindkraft FoU Seminar
Trondheim, 23. januar 2009

Olje- og energidepartementet www.regjeringen.no/oed

Energi og klima - "hånd-i-hånd"

To utfordringer på energisiden:

1. Verden trenger energi
2. Utslippene av klimagasser øker.





Olje- og energidepartementet www.regjeringen.no/oed

Klimaforliket

- FoU på fornybare energikilder og karbonfangst og -lagring økes
- Forskningscentre for miljøvennlig energi (FME)
- Demonstrasjon av teknologier for fornybare energikilder offshore



Olje- og energidepartementet www.regjeringen.no/oed

Hvorfor offshore vindkraft?

- Langsiktige muligheter
 - Vindressurser
 - Teknologi, kompetanse, erfaring
 - Regulerbar vannkraft
- Utfordringer
 - Teknologutvikling
 - Kostnader
 - Infrastruktur
 - Arealbruk



Olje- og energidepartementet www.regjeringen.no/oed

Interessen – prosjekter til behandling i NVE

- To gitte konsesjoner
 - Hywind, Karmøy – flytende testanlegg – ikke i drift
 - Havsul I – 1 TWh bunnfast - påklaget til OED
- Meldinger
 - Innenfor grunnlinja - 5 stk.
 - 6,5 TWh
 - Både flytende og bunnfast
 - Utenfor grunnlinja - 5 stk.
 - 18 TWh
 - Både flytende og bunnfast
 - Tas ikke til behandling



Olje- og energidepartementet www.regjeringen.no/oed

Virkemiddelapparatet for utvikling av ny teknologi

- Energi21 – FoU-strategi for energisektoren
- RENNERGI – Fremtidens rene energisystem
- Forskningscentre for miljøvennlig energi (FME)
- Enova SF





Olje- og energidepartementet www.regjeringen.no/oed

Nærmere om FME-ordningen

- Samarbeid, geografisk eller virtuelt, mellom utdanning, forskning og næring
- Konsentrert, langsiktig FoU-innsats på høyt internasjonalt nivå innen bestemte tema
- Bygge opp og synliggjøre kompetansesentre
- Prioriteringer i Energi21 ligger til grunn:
 - Energieffektivisering
 - Klimavennlig kraft (vann, offshore og onshore vind, sol)
 - CO2-nøytral oppvarming (bioenergi, varmepumper)
 - Energisystem for fremtiden (nett, infrastruktur)
 - CO2-fangst og lagring
 - Miljøvennlig transport



Olje- og energidepartementet

www.regjeringen.no/oed

Nasjonal strategi for marin fornybar energi

Aktuelle temaer:

- Teknologit utvikling/utprøving
- Lover/regler
- Arealavklaringsprosess
- Infrastruktur



Olje- og energidepartementet

www.regjeringen.no/oed

Teknologier for offshore vindkraft

- Faste installasjoner – er tatt i bruk
- Flytende installasjoner – nytt og uprøvd
- Norske erfaringer og teknologiske fortrinn fra energi- og petroleumsvirksomheten
 - Elkompentanse (vannkraft)
 - Maritim kompetanse (shipping)
 - Materialteknologi
 - Kabelteknologi
 - Offshoreteknologi
 - Flytere i stål og betong
 - Forankringssystemer
 - Offshore installasjoner
 - Offshore leverandørindustri



Olje- og energidepartementet

www.regjeringen.no/oed

Rettslig rammeverk

- Dagens energilov gjelder til grunnlinjen
- Lovforslag under arbeid
 - Energiforsyning/infrastruktur
 - Sikkerhet
 - Miljø
 - Arealbruksinteresser
- Arealtilnærming



Olje- og energidepartementet

www.regjeringen.no/oed

Arealtilnærming

- Åpning av arealer der det kan søkes
 - Gir offentlig kontroll og rasjonell/koordinert prosess
- Forhåndsklarering av myndighetene
 - Strategisk konsekvensvurdering
 - Teknisk/økonomisk screening
 - Ressurser, havdyp, nettutbygging/tilknytting, forbruk/avsetning
 - Konfliktvurdering
 - Miljø, fiskeri, skipsfart, petroleumsvirksomhet
 - Prefererte/søkbare arealer
 - Strategi/plan for åpning/konsesjonsbehandling

Olje- og energidepartementet

www.regjeringen.no/oed

Infrastruktur

- Kan knyttes til:
 - Nett på land
 - Nett i andre land
 - Petro-installasjoner
 - Eller kombinasjoner
- Arkitektur, systemansvar, eierskap, finansiering, tariffing

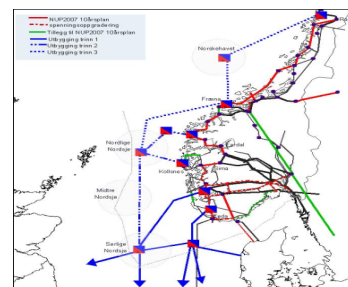

Olje- og energidepartementet

www.regjeringen.no/oed



Olje og energidepartementet

www.regjeringen.no/oed

part of Aker

Offshore vindkraft med bunnfaste stålunderstell Et nytt marked for Aker Solutions

Presentasjon på:
Vindkraft FoU Seminar – Fokus på offshore
Royal Garden Hotell Trondheim, 23. Januar 2009

Age Tårnes
Business Development Director – Offshore Wind
age.tarnes@akersolutions.com
+47 90 14 74 94

© 2009 Aker Solutions

Offshore Vindkraft med bunnfaste stålunderstell Et nytt marked for Aker Solutions

- Agenda
 - Aker Verdal AS / Aker Jacket Technology AS
 - Kort om offshore vindkraft generelt
 - Levering av stålunderstell til det første vindkraftprosjektet til havs i Tyskland – Alpha Ventus
 - Offshore Vindkraft i Norge – Muligheter ?
 - Eksport av stålunderstell til offshore vindkraft i Europa

part of Aker

Vindkraft FoU Seminar Trondheim, 23.01.2009 Slide 2 Aker Verdal AS

Aker Verdal - Utvikling av området



1971



2005
3 Buzzard stålunderstell klare for levering til UK



20.01.2009

part of Aker

Vindkraft FoU Seminar Trondheim, 23.01.2009 Slide 3 Aker Verdal AS



part of Aker

Vindkraft FoU Seminar Trondheim, 23.01.2009 Slide 4 Aker Verdal AS

788 ansatte i Aker Verdal og datterbedriftene

233 funksjonærer
555 operatører

Hvorav:
66 lærlinger
67 kvinner





part of Aker

Vindkraft FoU Seminar Trondheim, 23.01.2009 Slide 5 Aker Verdal AS

Aker Verdal

Referanser for stålunderstell

- Aker Verdal har siden 1974 levert til sammen 33 stålunderstell
- I løpet av de 10 siste årene har Aker Verdal levert mer enn 20 stålunderstell, de 5 siste til Storbritannia
- Marked for ytterligere 10-15 stålunderstell i perioden 2010-2015 til O&G - virksomheten













part of Aker

Vindkraft FoU Seminar Trondheim, 23.01.2009 Slide 6 Aker Verdal AS

Aker Jacket Technology



- Aker Jacket Technology er et heleid datterselskap av Aker Verdal som holder til i Aker Solutions hovedkontor på Fornebu
- Et høyt kvalifisert team av ingeniører som dekker struktur, marine og geotekniske disipliner
- I løpet av de siste 10 årene, design av 20 jackets for Nordsjøen
- Spesiell fokus på EPC prosjektgjennomføring som tar fordel av integrert engineering og fabrikasjon
- Engineering tjenester for konsept utvikling detaljprosjektering

Aker Solutions
part of Aker

Vindkraft FOU Seminar Trondheim, 23.01.2009 Side 7 Aker Verdal AS

Marked for Aker Solutions

- Storbritannia og Tyskland er det største markedet for offshore vindkraft, dette p.g.a rammeverk og støtteordninger
- Hittil er understell for offshore vindkraft dominert av monopeler som ikke er relevant for Aker Solutions
- Økende vanndybde/ turbinstørrelse krever andre understell som jacket, tripod eller tri-pile
- Tri-pile utvikles og leveres av totalleverandøren BARD, og denne løsningen er ikke aktuell for Aker Solutions
- Vi tror ikke at tripod er konkurransedyktig
- Vi mener at jacket stålunderstell er den mest konkurransedyktige løsningen for økende vanndybde/ turbinstørrelse

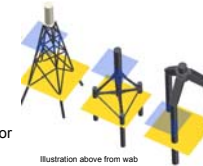
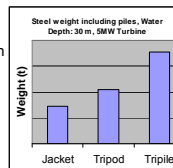

Illustration above from wab



Aker Solutions
part of Aker

Vindkraft FOU Seminar Trondheim, 23.01.2009 Side 8 Aker Verdal AS

Offshore vindkraft - Marked

- EU har en målsetting om 20% fornybar energi innen 2020
- 40 GW (ref. EWEA) må komme fra vind og en betydelig del av dette fra offshore vindkraft
- Med en kostnad (CAPEX) på opp mot 25 mill kroner pr. installert MW vil dette altså innebære at det må investeres opp mot 1000 mrd kroner for å nå dette målet. Dersom 5 MW turbiner benyttes kreves 8000 stk for å møte målsetting på 40 GW
- Store utbygginger med bunnfast (vanndybde opp mot 40 m) offshore vindkraft settes nå i gang i Europa da myndighetene har besluttet rammeverk, støtteordninger og incentivordninger, spesielt i Tyskland og Storbritannia (I Tyskland er utbyggeren garantert 1,20 kr/KWh i tillegg til at netteierne må sørge for kraftkabel fra vindpark og inn på nettet. Prisen er garantert over en periode som gir forutsigbarhet)

Aker Solutions
part of Aker

Vindkraft FOU Seminar Trondheim, 23.01.2009 Side 9 Aker Verdal AS

Offshore Wind Marked – Flaskehals, Begrensninger

- Produksjonskapasitet av offshore turbiner
 - Betydelig kapasitet bygges nå opp i Tyskland



Illustration above from wab

- Manglende kapasitet på transport og installasjon
 - Noe under bygging, men de fleste avventer langsiktige avtaler med utbygger

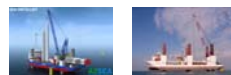

- Umoden teknologi, spesielt O&M, størrelse på offshore turbiner

Aker Solutions
part of Aker

Vindkraft FOU Seminar Trondheim, 23.01.2009 Side 10 Aker Verdal AS

Offshore Vindkraft – Industrielle muligheter

- Utbyggingene som nå settes i gang i Europa skaper nå store muligheter for industriene i disse landene, spesielt i Tyskland
- I Bremerhaven, Emden og Cuxhaven er det nå investert betydelig av både myndigheter og leverandørindustri i teknologiutvikling, produksjonsfasiliteter og infrastruktur. Dette området av Tyskland er derfor nå etablert som et senter for offshore vindkraft
 - Tyskland er nå langt på vei til å bli ledende innen offshore vindkraft, spesielt utvikling og produksjon av store turbiner (5-6 MW) for offshore vindkraft
- Mye av dette er vanskelig å ta igjen for norsk industri. Aker Solutions i Verdal ser imidlertid muligheter til å bli en betydelig EPC-leverandør av stålunderstell til Europa, inkludert Tyskland
- Aker Solutions må satse nå, ellers taper vi konkurransefortrinnet ved den erfaringen, teknologien og kompetansen vi har bygd opp fra 1974 til andre i Europa

Aker Solutions
part of Aker

Vindkraft FOU Seminar Trondheim, 23.01.2009 Side 11 Aker Verdal AS

Offshore Vindkraft – Oppbygging av ny industri i Tyskland

wab
Bremerhaven - Development for Offshore Wind 2008

wab
Ongoing investments in production facilities

BARD in Cuxhaven

Total invest. - 400 M€
Public infrastructure - 100 M€
Bremerhaven - 250 M€

WasserWind GmbH
Offshore-Windkraft-Industrie

Vindkraft FOU Seminar Trondheim, 23.01.2009 Side 12 Aker Verdal AS

Aker Verdal leverer 13 tripods - Hvem er kunden?

MULTIBRID GmbH



- PC-Contracts, design av OWT GmbH
 - Vi leverer om bord på lekter som leveres av kunde. Kunde er ansvarlig for transport og installasjon.
- Alpha Ventus – Client: Multibrud GmbH
 - Levering av 6 tripods sommer 2008
 - Tysklands første offshore utbygging
- Cote d'Albatre – Client: PROKON Nord GmbH
 - Levering av 7 tripods 2009



AkerSolutions
part of Aker

Vindkraft FOU Seminar Trondheim, 23.01.2009 Side 13 Aker Verdal AS

Alpha Ventus – Bygging på Aker Verdal



AkerSolutions
part of Aker

Vindkraft FOU Seminar Trondheim, 23.01.2009 Side 14 Aker Verdal AS

Alpha Ventus Tripods– Ankomst Wilhelmshaven 2.august 2008



Foto: www.alpha-ventus.de

Foto: www.alpha-ventus.de

AkerSolutions
part of Aker

Vindkraft FOU Seminar Trondheim, 23.01.2009 Side 15 Aker Verdal AS

Offshore vindkraft i Norge med bunnfaste stålunderstell

- Havmøller i Norge
 - Så langt har det blitt fokusert mest på flytende havmøller (dypt vann) som et mulig nytt produkt for eksport
 - Vil ikke kunne gi industrielle muligheter før om mange år
- I sørlige del av norsk sektor av Nordsjøen, store områder med 50-60 meters vannndyp
- På Sørlandet kan 1000 MW taes inn på nettet (200 stk 5 MW turbiner, 4 TW/år)
- Det er fullt teknisk mulig i Norge i dag å bygge ut 1000MW med bunnfaste understell med tilsvarende løsninger som det nå satses på i Europa
- I Norge bygges det verken ut eller er planer om utbygginger p.g.a manglende
 - Rammeverk og støtteordninger
 - Lovverk for offshore vindkraft
 - Konesjonsprosess
 - Infrastruktur nett
- Vi har til tross for dette ambisjon om å levere til demonstrasjonsprosjekt med bunnfast stålunderstell ved en eksisterende O&G-installasjon i sørlige Nordsjøen

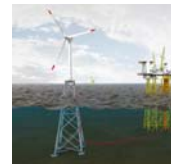

AkerSolutions
part of Aker

Vindkraft FOU Seminar Trondheim, 23.01.2009 Side 16 Aker Verdal AS

Offshore Vindkraft Europa – Bunnfast stålunderstell

- Aker Solutions har ambisjoner om å bli en ledende EPCI leverandør av bunnfaste stålunderstell til det store markedet som nå åpner seg i Europa
- Vi har en betydelig kapasitet ved å utnytte vårt eksisterende anlegg og kompetanse. Vi utreder nå planer for å etablere masseproduksjon av stålunderstell og behov for infrastruktur som er nødvendig for å nå dette målet
- Manglende kapasitet på egnede fartøyer for transport og installasjon er en vesentlig flaskehals. Vi er nå i dialog med samarbeidspartnere for transport og installasjon slik at vi kan tilby en effektiv EPCI-gjennomføring

AkerSolutions
part of Aker

Vindkraft FOU Seminar Trondheim, 23.01.2009 Side 17 Aker Verdal AS

The Aker Solution – Offshore wind, fixed steel substructures

- Aker Solutions vil levere EPCI jacket understell

- Aker Verdal har i løpet av de siste 15 årene vært den dominerende EPC jacket leverandør for olje & gass utbygginger i Nordsjøen. Vi har også gjennomført flere EPCI.

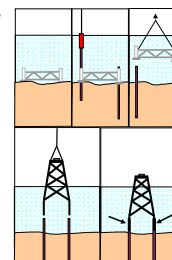

The Aker Solution

AkerSolutions
part of Aker

Vindkraft FOU Seminar Trondheim, 23.01.2009 Side 18 Aker Verdal AS

Aker Verdal – Være ledende på levering av stålunderstell til O&G i Europa



Vindkraft FOU Seminar Trondheim, 23.01.2009 Side 19 Aker Verdal AS part of Aker



Aker Verdal – Etablere masseproduksjon/ infrastruktur for eksport av stålunderstell til offshore vindkraft i Europa



Utvikle infrastruktur, etablere senter for offshore vindindustri (vindklynge) i Midt-Norge

- ScanWind
- Havnevesen
- Sarens Transrig
- Fosdalen Industrier
- Lafapa
- Hansen mek
- Visman
- Forskningsmiljø
- Chappdrive
- Smartmotor
- etc

Vindkraft FOU Seminar Trondheim, 23.01.2009 Side 22 Aker Verdal AS part of Aker



Copyright

Copyright of all published material including photographs, drawings and images in this document remains vested in Aker Solutions and third party contributors as appropriate. Accordingly, neither the whole nor any part of this document shall be reproduced in any form nor used in any manner without express prior permission and applicable acknowledgements. No trademark, copyright or other notice shall be altered or removed from any reproduction.

Vindkraft FOU Seminar Trondheim, 23.01.2009 Side 21 Aker Verdal AS part of Aker



Disclaimer

This Presentation includes and is based, inter alia, on forward-looking information and statements that are subject to risks and uncertainties that could cause actual results to differ. These statements and this Presentation are based on current expectations, estimates and projections about global economic conditions, the economic conditions of the regions and industries that are or will be major markets for Aker Solutions ASA and Aker Solutions ASA's (including subsidiaries and affiliates) lines of business. These expectations, estimates and projections are generally identifiable by statements containing words such as "expects", "believes", "estimates" or similar expressions. Important factors that could cause actual results to differ materially from those expectations include, among others, economic and market conditions in the geographic areas and industries that are or will be major markets for Aker Solutions' businesses, oil prices, market acceptance of new products and services, changes in governmental regulations, interest rates, fluctuations in currency exchange rates and such other factors as may be discussed from time to time in the Presentation. Although Aker Solutions ASA believes that its expectations and the Presentation are based upon reasonable assumptions, it can give no assurance that those expectations will be achieved or that the actual results will be as set out in the Presentation. Aker Solutions ASA is making no representation or warranty, expressed or implied, as to the accuracy, reliability or completeness of the Presentation, and neither Aker Solutions ASA nor any of its directors, officers or employees will have any liability to you or any other persons resulting from your use.

Aker Solutions consists of many legally independent entities, constituting their own separate identities. Aker Solutions is used as the common brand or trade mark for most of these entities. In this presentation we may sometimes use "Aker Solutions", "we" or "us" when we refer to Aker Solutions companies in general or where no useful purpose is served by identifying any particular Aker Solutions company.

Vindkraft FOU Seminar Trondheim, 23.01.2009 Side 22 Aker Verdal AS part of Aker





scanwind™
WIND TURBINES

ScanWind Built to last

Vindkraft FoU Seminar – fokus på offshore

Kristian Holm
Director Supply Chain
ScanWind Group AS





1

scanwind™
WIND TURBINES

Company History

- Established in 2000 for marketing of large wind turbines (>3.5 MW) based on own design
- R&D project consisting of technology development and testing of full scale prototypes under realistic operational conditions at Hundhammerfjellet Wind Park on the Norwegian coast – one of the most extreme wind park sites in the world
- Field testing 2003-2008 with very positive results (availability 97%)
- Hundhammerfjellet wind park finalized September 2008 (50,5 MW)
- Ready for serial production 2008/2009



Shareholder	Shares	%
WellPower Sweden AB	156 587	80,1 %
NTE Holding AS	36 060	18,5 %
Energjutvikling AS	2 786	1,4 %
Total	195 433	100 %

Total equity since start up MNOK 336





2

scanwind™
WIND TURBINES

ScanWinds deliveries and orders:

- 4 WTGs delivered to Hundhammerfjellet (NTE) 2003 – 04
 - Generation 1: Turbine 1 - 2 (demo's): SW 3 MW with 90m blades, PM-generator / variable speed gearbox
 - Generation 2: Turbine 3 - 4: SW 3 MW with 90m blades, PM-generator
- 7 WTGs installed at Hundhammerfjellet 3Q07
 - Generation 3: Turbine 5 - 11: SW 3.5 MW with 90m blades, PM-generator
- 4 WTGs installed at Hundhammerfjellet 3Q08
 - Generation 3: Turbine 12 - 15: SW 3.5 MW with 90m blades, PM-generator





3

scanwind™
WIND TURBINES

SW-90-3500

Rated power	3,5 MW
Turbine diameter	90,6 m
Power control	Pitch and torque control
No. of blades	3
Rotor speed	10 – 20 rpm
Cut-in wind speed	2,5 m/s
Cut-out wind speed	23-27 m/s
Rated wind speed	15,5 m/s
Pitch system	Individual electric on each blade
Yaw system	Electric
Generator	Direct drive, permanent magnet
Electrical voltage level	690 V / 22 kV
Energy production at Hundhammerfjell site	12,8 GWh





4

scanwind™
WIND TURBINES

Certification of SW-90-3500

- GL/Wind Test as certification body
 - Load calculations
 - Power curve
 - Noise emission
 - Completed end February 2009





5

scanwind™
WIND TURBINES

Market strategy:

“To focus our activities to become the premier offshore wind turbine supplier ”

- Market strategy**
 - Focus on markets close to us with high wind speeds and rough conditions:
 - Northern Europe Coastal onshore: IEC S, 1
 - Northern Europe Offshore: IEC S, 1
- Sales Targets**
 - 2009-2010
 - 45 turbines sold (60MW/year)
 - 2011-2012
 - 260 turbines sold (520MW/year)
 - 2013-2014
 - 400 turbines sold (800MW/year)



6

 **ScanWind offshore program**

ScanWind deliveries:

- Blades
- Nacelle (generator, control systems, power conversion, turbine backup and safety systems)
- Tower
- Services

Main focus on:

- Low operation and maintenance costs
- High production
- High availability
- Reduction of unnecessary visits to turbine

Experience:

- Utilizing experience from Hundhammerfjellet. Using this as research platform for new enhancements
- Tight collaboration with Norwegian offshore expertise



7

 **Development of SW-100-4000 offshore**

- Based on the existing design platform (SW-90-3500)
 - Evolution of existing design
 - Increased rotor diameter for increased production
 - Improved generator (4 MW+) for increased production
 - Improved redundancy
 - Improved control algorithms
 - Improved remote control systems

Calculated to give 20-25% increased power production compared to existing design without any major design changes.

Installation of first prototype offshore in 2011



8

 **Offshore wind – an industrial possibility**

- Estimated potential of 200 turbines produced annually
- Includes production of foundations, tower, nacelle and blades
- An industry with a potential annual turnover of more than MNOK 10.000,-
- Assembly and testing to be done in Verdal
- 400 employees in ScanWind in 2013
- Cooperation between Aker and ScanWind is currently evaluated
- Huge interest for offshore turbine concept is shown by both Vattenfall and Lyse



9

 **Challenges**

- Lack of incentives for building new wind industry. Support for investments favours already established industry.
- No feed-in-tariffs established for green energy.
- Export guarantees (GIEK) is in place and functions well. No similar systems for national (Norwegian) deliveries.
- No support for industry that are in a semi-commercial phase (developed product, low production volume).
- Lack of pilot projects for commercialisation of new technology.

10

 **Offshore wind – an industrial possibility**



11

SWAY

OFFSHORE VIND 2010-2020

Vindkraft FoU Seminar, Royal Garden Hotell,
22-23 januar 2009

v/ Eystein Borgen Sway A/S

1

SWAY

Bakteppe:

Ikke bare klima...
I 2030 vil EU importere:

- 94% av oljen
- 84% av gassen
- 59% av kullet

Kilde: European Energy and Transport; Trends to 2030 –update 2005:
European Commission May 2006

2

SWAY

Offshore vind versus "business as usual"

- Større energiavhengighet
- Lavere energikostnader
- Redusert brenselkost risiko
- Økt konkurranseevne
- Økt teknologiekspert
- Reduserte klimautslipp

3

SWAY

Summary of the wind industry target for the EU-27 in 2020

- 180 GW installed capacity, including 35 GW offshore
- Annual installations of 16.8 GW, including 6.8 GW offshore
- Electricity production of 477 TWh, including 133 TWh offshore
- Meeting between 11.6% and 14.3% of total EU electricity demand (depending on 2020 demand).
- 18.1% of total installed electricity generating capacity in the EU
- 32% of total new electricity generating capacity installed (2011-2020)
- Providing power equivalent to the needs of 107 million average EU households (49% of EU households)
- Avoiding 328 Mt of CO₂ – equivalent to taking 165 million cars off the road (76% of the EU 2004 car fleet) and equal to 44% of the EU's GHG reduction target (20%)
- Annual avoided fuel cost of €20.5 billion (assuming fuel prices equivalent to \$90 a barrel of oil)
- Annual avoided CO₂ costs of €8.2 billion (€25/t CO₂)
- Annual investments in wind power capacity of €16.9 billion
- Total wind power investments of €120 billion (2011-2020)
- Total life-time avoided fuel costs of wind power capacity installed in 2011-2020 of €277 billion (assuming fuel prices equivalent to \$90 a barrel of oil)
- Total life-time avoided CO₂ cost of wind power capacity installed in 2011-2020 of €114 billion (assuming €25/t CO₂)

Kilde: Pure Power –Wind Energy Scenarios Up To 2030- EWEA

4

SWAY

FIG 1.3: EU Energy mix 1995 (Total 532 GW)

Source: EWEA and Platts PowerVision

FIG 1.4: EU Energy mix end 2007 (Total 775 GW)

Source: EWEA and Platts PowerVision

5

SWAY

FIG 0.1: 16 years of global wind energy development (1991-2006) compared to the first 16 years of nuclear development (1961-1976)

Kilde: Pure Power –Wind Energy Scenarios Up To 2030- EWEA

6

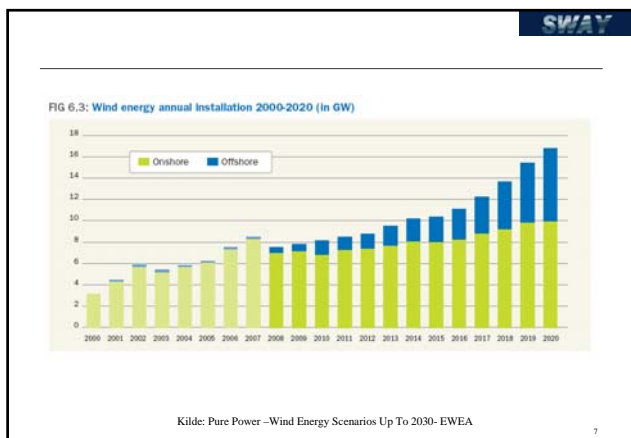

- SWAY**
- Hva skal til for å utløse potensialet?:
- Tilrettelegging for marked – Nett+”fri flyt”
 - Myndighetsprosesser/konsesjon
 - Fullskala testing av ny teknologi
 - Bygge driftserfaring – redusere prosjektrisiko
 - Myndighetsstøtte i overgangsperioden, ”hønen og egget”
 - Kostnadsreduksjon
- 8

- SWAY**
- ## Kostnadsreduksjon
1. Ballanse i markedet – tilbud/etterspørsel
 2. Driftssikkerhet
 3. Teknologisprang
 4. læringskurve
 5. Volum
- 9

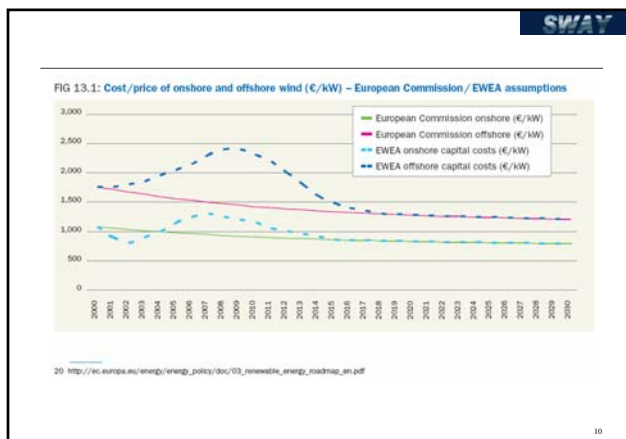

- SWAY**
- ## Driftssikkerhet
- Robust design gjennom:
- Girløs?
 - Minimere antall mekaniske systemer
 - Optimalisere komponent pålitelighet
 - 3-5 års planlagt vedlikeholdsintervall?
 - Effektive og sikre tilkomstsystemer
 - Drifts og vedlikeholdsrutiner - monitorering
 - Tilrettelegge for utskifting av komponenter
- 11

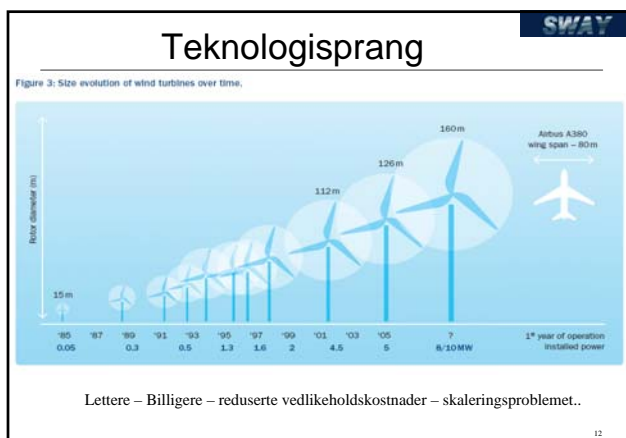

Oppsummering

SWAY

- 40-50% total kostnadsreduksjon offshore (fra 2008) kan være realistisk innen 2020
- Dypt vann = grundt vann = onshore (cost of energy)
- Et tidsspørsmål før offshore vind på både grundt og dypt vann tar virkelig av globalt
- Subsidiefri drift offshore innen 2020 realistisk
- EWEA's offshore mål realistiske hvis myndighetene legger til rette med infrastruktur (nettutbygging + deregulering av transmisjonsmarkedet mellom EU landene)

13



SWAY

Classification: Internal Status: Draft

Status Hywind og Vedlikeholds strategier for offshore vind

Elly Karlsen

StatoilHydro

2

- Status Hywind
- Teknisk Status
- Simulering av driftsmodeller
- D&V innen vindkraft i SH

StatoilHydro

Classification: Internal Status: Draft

Status Hywind

StatoilHydro

4

Status Hywind

- Substruktur i produksjon
- Sjøkabel produseres
- Base og havn er valgt, Skudesnes
- Båt for transport av personell er reservert.



- Prosjektet er på tid og kost
- Oppstart 1st 10. 2009



StatoilHydro

5

F&U områder innen Hywind

- Overall behaviour
 - Bevegelses mønster
 - Spesielt i lys av hvilket kontrollsystem som blir brukt
 - Vind trustens og bølgenes påvirkning på strukturen (pitch bevegelsen)
 - Akselerasjon spesielt i Nacellen
 - Mekaniske spenninger i tårn og sub-struktur
- Availability / Flexibility
- Tilkomst

StatoilHydro

Classification: Internal Status: Draft

Drift og Vedlikehold

StatoilHydro

Teknisk Status

Status

- Data lite tilgjengelig
- Feilårsaker ikke defineres entydig
- Nedbrytning gjøres ikke likt

Hva gjør SH?

- Bruker RDS-PP for nedbrytning
- Kjørere FMECA for riktig kategorisering
- Etablere system for feildata for egne turbiner

Component	Value
RFA_Hydrologic system	0.1200
RFA_T23 tower	0.12500
RFA_Aerodynamics	0.0450
RFA_Tower system	0.1350
RFA_Control system	0.0700
RFA_Grid system	0.4500
RFA_Cable system	0.0215
RFA_Cable	0.3000
RFA_Rotor Huber system	0.1475
RFA_Gearing	0.2700
RFA_Hydrodynamic loss	0.0900
RFA_Support structure	0.0900
RFA_Rotor	0.1700
RFA_Turbine nacelle	0.0675
RFA_Rotor structure	0.1125
RFA_Cable of support	0.4970
RFA_Tower structure	0.2000
RFA_Inverter cabinet	0.4970
RFA_Structure parts	0.1800
RFA_Controls	0.0900
Total	0.8700

StatoilHydro

Drift og vedlikehold

- Basert på RAM analyse velges strategier for videre detaljering
- Driftskostnader estimeres normalt i verktøy fra ECN
- SH gir grenseverdier og rater
- Resultatet gjør det mulig å optimalisere strategien og "prøve ut" løsninger
- Blir brukt til å påpeke forbedringsområder inne DV.

StatoilHydro

Driftskost følsomhet

- Tomado diagram indikerer:
 - Fokuser på fartøy mob tid
 - Fokuser på forbedring av yaw, gir og generator

Regression Sensitivity for Availability

Regression Sensitivity Total Costs per kWh

StatoilHydro

Nedbrytning av driftskost

- Ikke planlagt vedlikehold utgjør i dag 73% av total vedlikeholds kost.
- Ventetid på mobilisering av utstyr og deler dominerer kostnadene knyttet til ikke planlagt vedlikehold
- Strategi for reservedeler og fartøy blir drivende for kostnadene

StatoilHydro

Drift og Vedlikehold av Vindturbiner i StatoilHydro

Prinsipper	Kompetanse områder
<ul style="list-style-type: none"> Bruk SH kunnskap innen vedlikehold Utøv sterkere eierskap Bruk erfaring inne IO Bruk av vedlikeholds kontrakter men ikke full O&M service kontrakt 	<ul style="list-style-type: none"> Vedlikehold <ul style="list-style-type: none"> Lang erfaring med effekten av planlagt kontra ikke planlagt vedlikehold. Offshore drift Fjernstyring og diagnose

StatoilHydro

Classification: Internal Status: Draft

Takk for oppmerksomheten

StatoilHydro

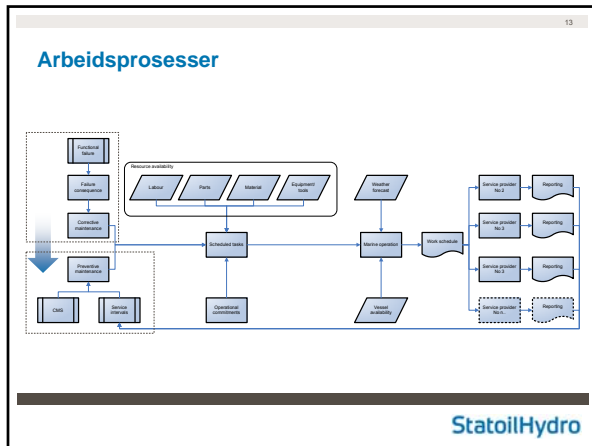

SINTEF Energiforskning AS
Adresse: 7465 Trondheim
Telefon: 73 59 72 00

SINTEF Energy Research
Address: NO 7465 Trondheim
Phone: + 47 73 59 72 00